

subject to technical alterations

type: D
range: 0 - 10 mm
range of indication: 0 - 10,5 mm
digital step: -
scale interval: 0,005 mm
measuring force: 1,2 -1,6 N
weight: 170 g

acceptable deviations
 VDI/VDE/DGQ 2618 Bl. 12.1/13.1)
max. permissible errors "G": 0,015 mm
repeatability "r": 0,005 mm
reference temperature: 20° C
operation temperature: 10° C - 30° C
storage temperature: -10° C - 50° C

scale: 1:1
drawing-nr.: DAB-D1R10S_KR_e
date of issue: 08.01.09
name: T.Koenig
revision status: 2000
revision date: 06.09.2012

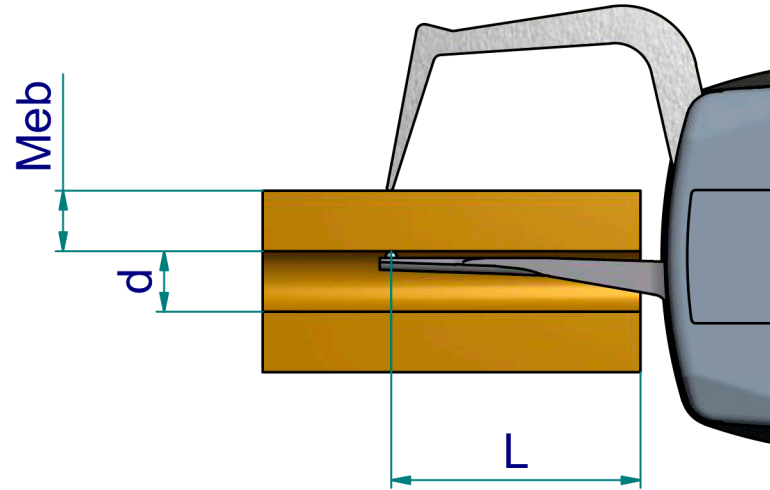

measuring capacity

measuring range Meb [mm]

Internal diameter d [mm]

	1	2	3	4	5	6	7	8	9	10
3	4,1	3,6	3,6	3,8	4,2	4,7	5,4	6,4	8,0	10,7
4	19,0	17,0	17,0	17,8	19,4	20,8	21,6	22,6	23,7	24,9
5	24,7	23,8	23,8	24,2	24,9	25,7	26,8	28,0	29,3	30,9
6	29,5	28,4	28,4	28,9	29,7	30,7	31,9	33,4	35,0	35,6
7	34,2	32,9	32,9	33,5	34,5	35,6	35,6	35,6	35,6	35,6
8	35,6	35,5	35,5	35,6	35,6	35,6	35,6	35,6	35,6	35,6
9	35,6	35,6	35,6	35,6	35,6	35,6	35,6	35,6	35,6	35,6
> 10	35,6	35,6	35,6	35,6	35,6	35,6	35,6	35,6	35,6	35,6
L										

L = maximum usable arm length [mm]

Example:
d = 5 Meb = 4 L = 24,2

subject to technical alterations

drawing-nr.: DAB-D1R10S_KR_e
date of issue: 08.01.09
name: T.Koenig

revision status:
revision date: