

range of application	range	range of indication
measuring contact 1	50 - 70 mm	49,5 - 70,5 mm
measuring contact 2	60 - 80 mm	59,5 - 80,5 mm
measuring contact 3	70 - 90 mm	69,5 - 90,5 mm
measuring contact 4	80 - 100 mm	79,5 - 100,5 mm

subject to technical alterations

type: H
 range: see table
 range of indication: see table
 digital step: -
 scale interval: 0,01 mm
 measuring force: 1,1 - 1,6 N
 weight: 220 g

acceptable deviations
 VDI/VDE/DGQ 2618 Bl. 12.1/13.1)
 max. permissible errors "G": 0,03 mm
 repeatability "r": 0,015 mm
 reference temperature: 20° C
 operation temperature: 10° C - 30° C
 storage temperature: -10° C - 50° C

scale: 1:1
 drawing-nr.: DAB-H2M50_KR_e
 date of issue: 09.01.09
 name: T.Koenig
 revision status:
 revision date:

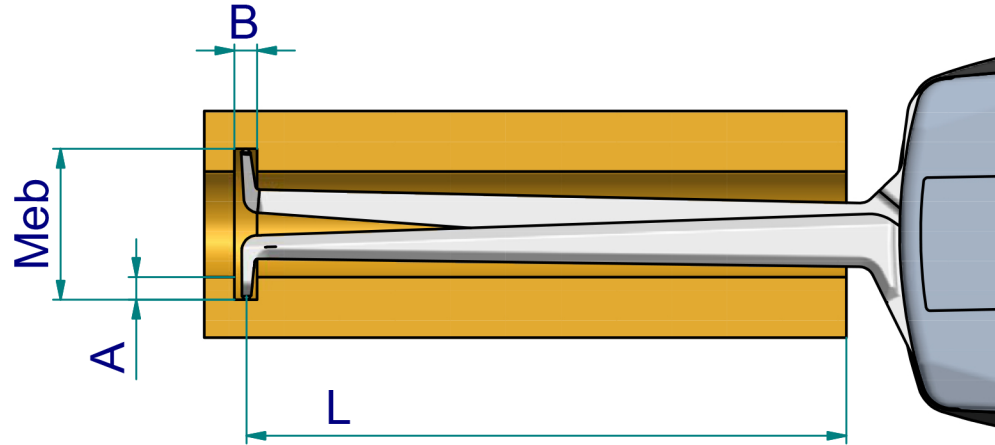

measuring capacity

		measuring ranges Meb [mm]										
		50	52	54	56	58	60	62	64	66	68	70
measuring contact 1 :		50	52	54	56	58	60	62	64	66	68	70
measuring contact 2 :		60	62	64	66	68	70	72	74	76	78	80
measuring contact 3 :		70	72	74	76	78	80	82	84	86	88	90
measuring contact 4 :		80	82	84	86	88	90	92	94	96	98	100
groove depth A [mm]	0	0 / 81,5	0 / 82,2	0 / 82,9	0 / 83,9	0 / 85,5	0 / 86,6	0 / 87,0	0 / 87,3	0 / 87,5	0 / 87,8	0 / 88,3
	1		1,5 / 81,8	1,5 / 82,5	1,5 / 83,2	1,5 / 84,4	1,5 / 86,0	1,5 / 86,8	1,5 / 87,1	1,5 / 87,3	1,5 / 87,5	1,6 / 87,7
	2			1,7 / 82,0	1,7 / 82,7	1,7 / 83,6	1,7 / 85,0	1,7 / 86,4	1,7 / 86,9	1,7 / 87,0	1,7 / 87,2	1,7 / 87,4
	3				1,9 / 82,3	1,9 / 83,0	1,9 / 84,0	1,9 / 85,7	1,9 / 86,6	1,9 / 86,8	1,9 / 87,0	1,9 / 87,2
	4					2,1 / 82,5	2,1 / 83,2	2,1 / 84,5	2,1 / 86,0	2,1 / 86,6	2,1 / 86,7	2,1 / 86,8
	5						2,2 / 82,7	2,2 / 83,6	2,2 / 85,0	2,2 / 86,2	2,2 / 86,5	2,2 / 86,6
	6							2,4 / 82,9	2,4 / 83,9	2,4 / 85,4	2,4 / 86,2	2,4 / 86,4
	7								2,6 / 83,1	2,6 / 84,2	2,6 / 85,4	2,6 / 86,2
	8									2,8 / 83,3	2,8 / 84,1	2,8 / 85,9
B / L												

subject to technical alterations

B = minimum groove width [mm]
L = maximum usable arm length [mm]

Example: Meb = 86 B = 1,7
 A = 2 L = 82,7

drawing-nr.: DAB-H2M50_KR_e
date of issue: 09.01.09
name: T.Koenig

revision status:
revision date: