

Comparative Measurement



TESA YA COMPLETE INSTRUMENT SETS

Specially designed for small bores from 0,47 up to 12,20 mm - Checking of dimension and bore form errors through 2-point measuring - Offers an excellent repeatability. The YA bore gauges consist of an interchangeable measuring head with a built-in needle and handle with a 8 mm diameter fixing bore for a dial gauge or any other type of sensor

- Measuring heads with spherical faces for through bores.
- Measuring heads for particularly deep bores.

Can be supplied on request:

- Measuring heads with carbide measuring faces.
- Measuring heads for special applications.
- Measuring heads for blind bores and particularly deep bores with other application ranges.
- Carbide measuring needles.
- Depth extensions 125, 250, 500, 750 and 1000 mm.

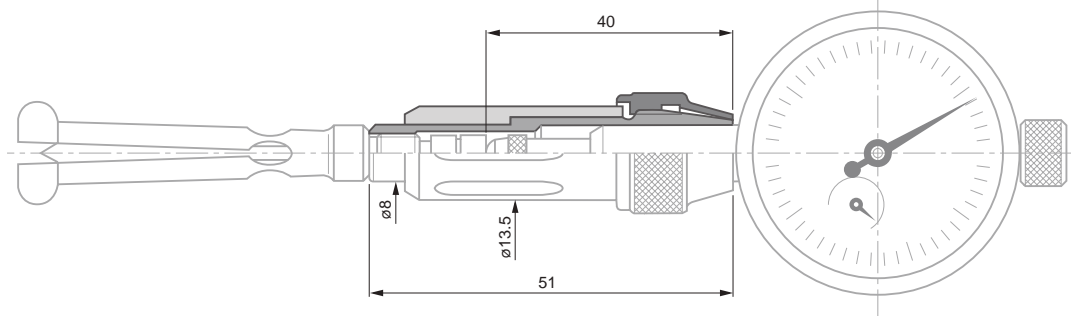
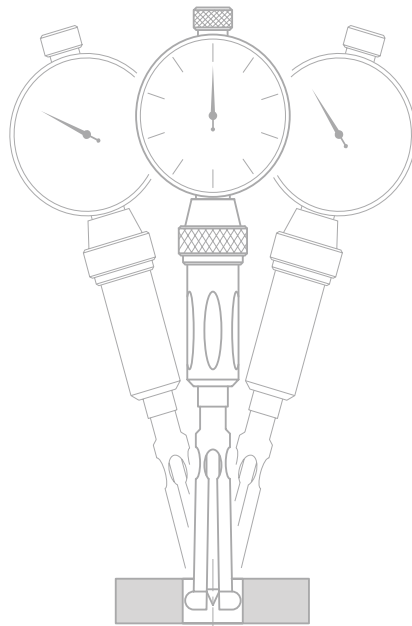

COMPLETE INSTRUMENT SETS FOR MEASURING THROUGH BORES



See table

1 μ m

Reliability of engraved dimension:
 $\pm 2s = 1 \mu$ m

Measuring head in hardened steel and carbide, ≈ 1000 HV 25
Measuring needles in hardened steel, ≈ 800 HV 25
Setting rings: with synthetic sapphire for nominal $\varnothing \leq 1,5$ mm and hardened steel for $> 1,5$ mm, ≈ 780 HV 25

Holder: Mounting of instruments with stem $\varnothing 8$ h6 mm

Technical data: see component sets

Complete set includes:
1 handle No. 01540201.
Measuring heads, needles and setting rings as shown in the table below.
1 TESA COMPACT dial gauge No. 353 (reading to 0,01 mm, $\varnothing 40$ mm dial)
1 Extension for for inserts, 10 mm No. 03540501.

Plastic case

Declaration of conformity



No



mm

01510000	0,47 ÷ 0,97
01510100	0,95 ÷ 2,45
01510200	2,30 ÷ 6,20
01510300	6,00 ÷ 12,20

	No	mm	Measuring depth max. mm	Measuring depth min. mm	No	No	\varnothing
	Measuring heads				Needles	Setting rings mm	
COMPOSITION OF THE SETS:							
01510000	01540401	0,47 ÷ 0,53	1,5	0,25	01540001	01540601	0,50
	01540402	0,52 ÷ 0,58	1,8	0,27	01540001	01540602	0,55
	01540403	0,57 ÷ 0,67	2,0	0,29	01540002	01540603	0,60
	01540404	0,65 ÷ 0,77	2,5	0,31	01540002	01540604	0,70
	01540405	0,75 ÷ 0,87	2,8	0,33	01540002	01540605	0,80
	01540406	0,85 ÷ 0,97	3,0	0,35	01540002	01540606	0,90
01510100	01540407	0,95 ÷ 1,15	11	0,6	01540003	01540607	1,00
	01540408	1,07 ÷ 1,25	11	0,6	01540003	01540608	1,10
	01540409	1,17 ÷ 1,35	11	0,6	01540003	01540609	1,20
	01540410	1,27 ÷ 1,45	11	0,6	01540003	01540610	1,30
	01540411	1,37 ÷ 1,55	11	0,6	01540003	01540611	1,40
	01540412	1,50 ÷ 1,90	17	0,9	01540004	01540612	1,50
	01540413	1,70 ÷ 2,15	17	0,9	01540004	01540613	1,75
	01540414	2,05 ÷ 2,45	17	0,9	01540004	01540614	2,00
					01540615	2,25	
01510200	01540415	2,30 ÷ 2,75	22	1,2	01540005	01540616	2,50
	01540416	2,65 ÷ 3,20	22	1,2	01540005	01540617	3,00
	01540417	3,05 ÷ 3,50	22	1,2	01540005	01540618	3,25
	01540418	3,35 ÷ 3,85	22	1,2	01540005	01540619	3,50
	01540419	3,80 ÷ 4,30	22	1,2	01540005	01540620	4,00
	01540420	4,20 ÷ 5,00	40	2,0	01540006	01540621	4,50
	01540421	4,70 ÷ 5,50	40	2,0	01540006	01540622	5,00
	01540422	5,30 ÷ 6,20	40	2,0	01540006	01540623	5,75
01510300	01540423	6,00 ÷ 6,80	40	2,0	01540006	01540624	6,50
	01540424	6,60 ÷ 7,50	40	2,0	01540006	01540625	7,00
	01540425	7,30 ÷ 8,15	40	2,0	01540006	01540626	7,75
	01540426	8,00 ÷ 8,80	40	2,0	01540006	01540627	8,50
	01540427	8,50 ÷ 9,40	50	2,0	01540006	01540628	9,00
	01540428	9,15 ÷ 10,00	50	2,0	01540006	01540629	9,50
	01540429	9,60 ÷ 10,80	50	3,3	01540007	01540630	10,00
	01540430	10,65 ÷ 12,20	50	3,3	01540007	01540631	11,50



Special Executions

Available upon request :

- Full instrument sets for measuring blind bores and short centering shoulders.
- Measuring heads with tungsten carbide tipped measuring faces.
- Measuring heads for special applications.
- Measuring heads for through bores, particularly deeper ones covering other application ranges.
- Tungsten carbide measuring needles.
- 125, 250, 500, 750 and 1000 mm depth extensions.

Optional Accessories for TESA YA Bore Gauges

Measuring stand for stationary use.



For technical details, see INTERRAPID UA30 measuring supports



Declaration of conformity



01639009 INTERRAPID UA 30 Support

MUST BE EQUIPPED WITH:

01610201 UK 25 sliding arm.
Used with TESA YA for stationary bore measurement on UA30 support.

01640000 UAZ 10 depth stop plate for UA 30



TESA VERIBOR

Proven design and reliability never questioned over decades – Instruments for 2-point measurements for bores from 4,5 up to 550 mm – Detects form errors – Gauge body with a 8 mm diameter clamping bore for a dial gauge, precision indicator or any other sensor.

- Excellent repeatability due to the circular element fixed on the instrument ensuring practically no play.
- Gauge body made of invar steel to neutralise the influence of the operator's hand warmth on the measuring result.
- Centring shoe for correct alignment of the instrument in the bore.
- Tungsten carbide ball tips for high resistance to wear.

TESA VERIBOR Light

Instrument with 2 contact points for comparative measurement of bores and detection of form errors – Automatic self-centering in the bore – Can be used with a dial gauge, a precision indicator or a probe with $\varnothing 8h6$ clamping stem.

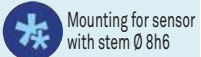
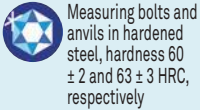

No	=	Measuring bolt travel, mm	mm	Measuring depth, mm
05710090	TESA Veribor light	1,30	18 ÷ 35	176
05710091	TESA Veribor light	1,40	35 ÷ 60	178
05710092	TESA Veribor light	1,40	50 ÷ 150	178
05710093	TESA Veribor light	1,30 / 1,40	18 ÷ 150	176 / 178

Sets delivered without dial gauge



TESA VERIBOR



- See table of values
- Only VERIBOR without dial gauge: 2 µm
- Only VERIBOR without dial gauge: ± 2s = 0,5 µm
- Measuring bolts and anvils fitted with carbide ball tips
- Mounting for sensor with stem Ø 8 h6 mm
- Set including 1 single TESA VERIBOR, 1 set of interchangeable fixed inserts covering the whole application range.
- Wooden case
- Declaration of conformity

05710012	4,5 ÷ 6
05710013	6 ÷ 12,5
05710014	12 ÷ 25
05710015	25 ÷ 50
05710016	50 ÷ 150
05710018	50 ÷ 300
05710017	240 ÷ 550

Sets supplied without dial gauges, electronic probes or indicators

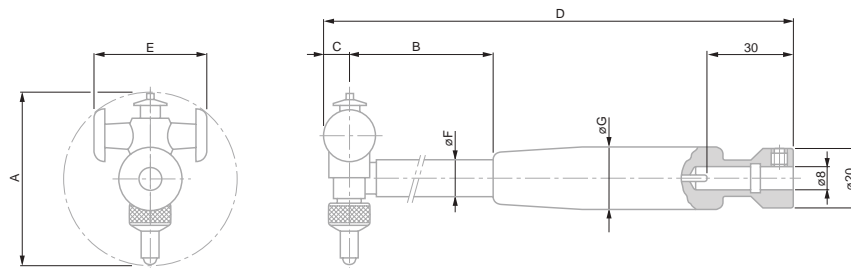

A mm	mm	B mm	C mm	D mm	E mm	F mm	G mm
4,5 ÷ 6	0,35	74	2	138	3,3	3,8	16
6 ÷ 12,5	0,5	93	2,6	156	4,3	4,9	16
12 ÷ 25	0,9	106	4,5	194	7,8	7,9	19
25 ÷ 50	1,3	140	6	228	16	8	19
50 ÷ 150	1,4	173	10	279	36	12	23
50 ÷ 300	1,4	173	10	279	36 / 66	12	23
240 ÷ 550	1,6	227	14	347	112	18	28

Special Versions

Available on request :

- TESA VERIBOR for blind bores and centring shoulders.
- TESA VERIBOR elbow-shaped for hard-to-reach bores.
- Handtools for measuring the distance between two plan-parallel surfaces.
- Handtools for inspecting gear pitch diameters.



ACCESSORIES FOR TESA VERIBOR

Set of Extensions

For extending the application range to \varnothing 300 mm for VERIBOR No. 05710016, 05710058 et 05710065.

No	=	
05740001	Set of extensions	Consisting of – 1 Centring shoe – 3 Extensions 50 mm



Depth Extensions

To be mounted on the body of VERIBOR $\varnothing \geq 25 \leq 550$ mm for large measuring depths (dimension B in the technical drawing of the VERIBOR).

No	=	
05760029	Extension	mm 1000
05760027	Extension	500



Dial Gauge Protection Guard

Protects the dial gauge against direct shocks and prevents the dial from being inadvertently rotated.

No	=	
05760013	Protection guard	mm \varnothing 58



ARM GAUGES

Very practical comparative measuring instrument – Measures at 2 or 3 points depending on the accessory used – Ideal for blind or through bores – also suited for measuring grooves, flutes as well as the internal measurement of parts with parallel faces.

IRA 2 Comparative Gauge

- Large application range from 10 to 150 mm
- Easy to handle thanks to its light weight and ergonomic design
- Built-in indicator with 0,01 mm reading and fine setting
- Centering device for 2-point measurement

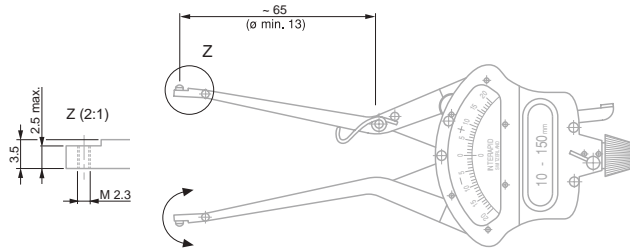
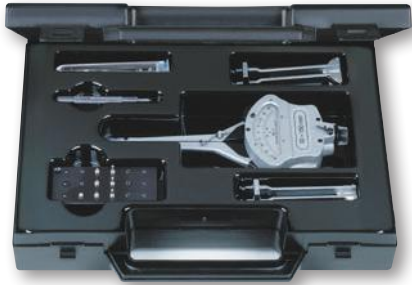

No	=	A
079105704	INTERAPID IRA 2	mm
079111401	INTERAPID IRA 2, carbide	mm
DELIVERED WITH THE FOLLOWING ACCESSORIES:		
079105667	3 inserts, hardened steel (order number for 1 unit, with 079105704)	
079105756	3 inserts, carbide (order number for 1 unit, with 079111401)	
079105668	3 short inserts, hardened steel (order number for 1 unit)	
079105669	3 long inserts in hardened steel (order number for 1 unit)	
079112126	2 inserts, adjustable for internal dia. >6mm	
079110110	Large insert holder for 3-point measurement	
079108502	IRA centering arm, Ø 15-30 mm	
079110111	Small insert holder for 3-point measurement	
079105694	Special screwdriver for IRA set	

Optional Accessories for IRA-2 Comparative Gauge

No	=
079112051	Small insert set for 3-point measurement
079112052	Long insert set pour 3-point measuring

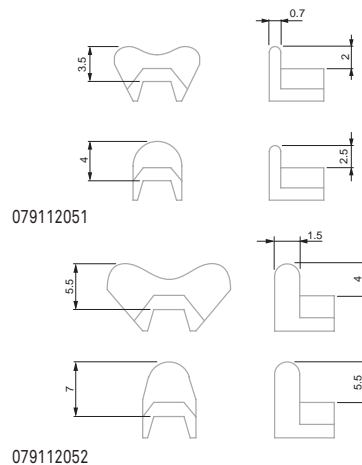
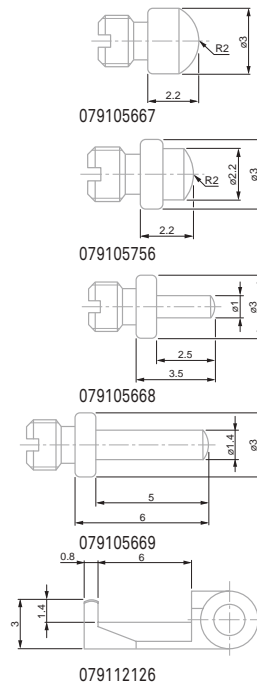
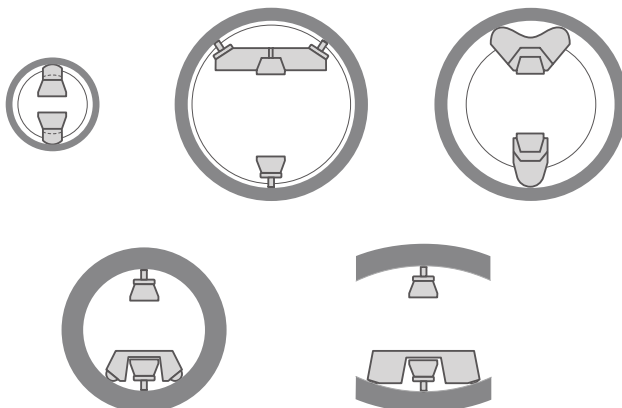

- ± 0,20 mm or ± 0,008 in
- 10 ÷ 150 mm 0.375 ÷ 6 in
- 0,01 mm or 0.0005 in
- Measuring inserts in hardened steel or tungsten carbide, see opposite table
- 3,5 N
- Measuring arm clearance travel: 10 mm
- Plastic case
- Declaration of conformity



- Chrome plated, hardened steel



Ø 57 mm

0,2 mm

Dial gauge: 5 µm

30 mm throat depth.
Highly stable frame
with heat insulating
handle.

≈ 2 N

Non-interchan-
geable measur-
ing inserts. With device
for retraction of
inserts.

Cardboard box

Declaration of
conformity

THICKNESS GAUGES

Designed for the direct measurement of thickness of all types of materials: plastics, glass, wood, felt, paper, rubber, etc.

Each gauge is equipped with a rotating dial for zero setting.

Model for Sheets



074115664 Thickness gauge for sheets

mm
0 ÷ 1

mm
0,001

Flat, mm
Ø 6,35



Ø 57 mm

10 mm

Dial gauge: 40 µm

Interchangeable
measuring inserts

Cardboard box

Declaration of
conformity

Models with Open Inserts When Not in Use



	mm	mm	mm	mm	Paired inserts included
074115604	0 ÷ 30	0,1	50	flat; Ø 30	074115686
074115605	0 ÷ 30	0,1	50	flat; Ø 20	074115687
074115606	0 ÷ 30	0,1	50	flat; Ø 10	074115726
074115607	0 ÷ 30	0,1	50	convex; Ø 10	074115727
074115608	0 ÷ 30	0,1	50	spherical; Ø 5	074115728



INTERAPID SHE.30 & SHE.35 SMALL HORIZONTAL MEASURING BENCHES

Extremely practical and very precise, these measuring benches are mainly used for the inspection of batches of precision parts as used in the watch making and precision mechanical sectors – Rapid measuring and easy setting from one part to the other – Wide choice of measuring inserts specially designed for the most varied of metrology applications.

INTERAPID SHE.30 for External Dimensions



No	=
03330004	INTERAPID SHE 30 small measuring horizontal bench for external dimensions (without measuring inserts)
OPTIONAL ACCESSORY:	
03360300	Measuring inserts, carbide, length 3,5 mm, height 0,4 mm

Measuring inserts, either cylindrical or knife-edged are available on request.

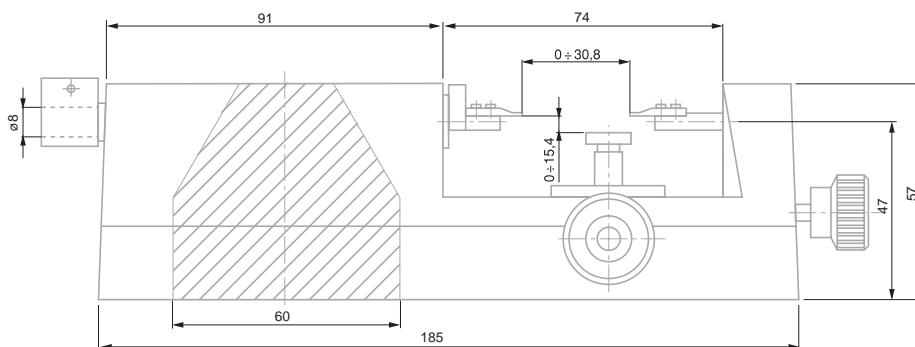

Pair of Measuring Inserts in Special Version

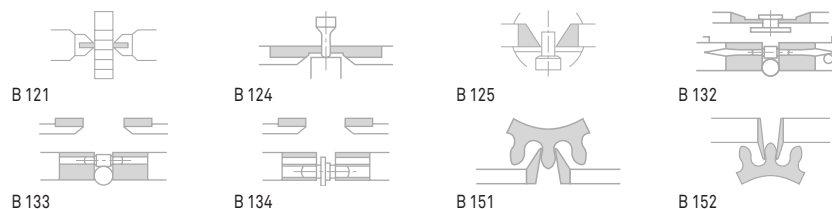

0 to 30 mm



Accuracy is usually influenced by the measuring instrument used as well as both flatness and parallelism of the measuring faces of inserts.

Holder precision: Flatness tolerance of two clamping faces: 0,05 mm. Axial positioning tolerance for the two indexing pins with respect to bolt axis: 0,05 mm. Tolerance for the parallelism of the table surface with respect to the bolt axis: 0,05 mm. See drawing



Main body in cast iron. Other parts in steel, hardened and ground



Produced by sensor used. The SHE.30 model is not spring-loaded.



Mobile measuring bolt: guided on a smooth bearing surface and equipped with a semi-circular disc for bolt retraction. Measuring inserts, assembled in pairs, and mounted on the measuring bolt and fixed anvil with a 1 mm diameter pin and 2 M1,4 screws. Support table with possibility of vertical and longitudinal adjustment: Surface 24 x 9,5 mm. Adjustment range: vertical: 15 mm, longitudinal: 14 mm. With fixing screw. Sensor (not included in the supply for SHE 30 bench): electronic indicator, mechanical or precision dial gauge, axial analogue or digital probe with mounting shank of Ø 8 mm



2,1 kg



Transport packaging



Declaration of conformity

INTERAPID SHE.35 for Internal Dimensions

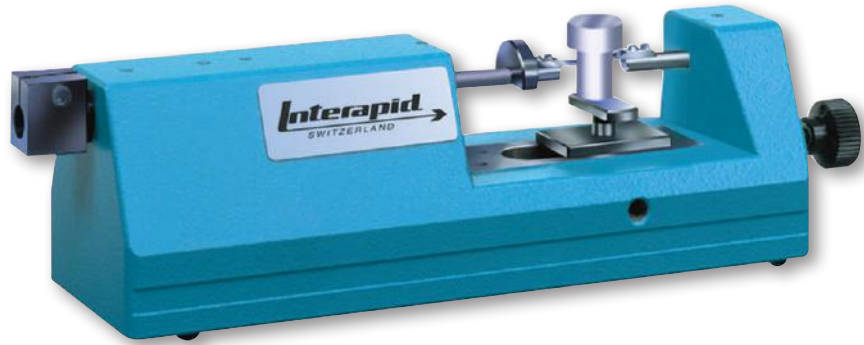

30 mm



8 to 38 mm (standard accessory)



Accuracy is generally influenced by the measuring instrument as well as the type of inserts used.



Main body in cast iron. Other parts in hardened and ground steel. Inserts with carbide measuring faces.



Produced by sensor used. The SHE.35 bench is not equipped with a spring.



Mobile measuring bolt guided on a flat bearing surface, also fitted with a retracting ball-shaped handle. Interchangeable measuring inserts supplied in pairs. Fixing shaft \varnothing 4 mm. Height adjustable support table. Surface: 40 x 70 mm. Setting range: 8 mm. 1 tightening screw. Sensor (must be ordered separately), e.g. dial gauge, electronic or precision indicator, analogue or digital probe. Mounting \varnothing 8 mm.



2,3 kg



Transport packaging



Declaration of conformity



03330006 INTERAPID SHE 35 small horizontal measuring bench for internal dimensions (with measuring inserts)

8 ÷ 38 mm

Inserts with special design also available on request

