



The Right Connection®

Couplings and Accessories

D  
I  
X  
O  
N



EUROPE.DIXONVALVE.COM  
+44 (0) 1772 323 529

DGEL  
2020

Uncommon Excellence • Uncommon Excellence • Uncommon Excellence • Uncommon Excellence



The Right Connection®

# Table of Contents

## CAM & GROOVE

Pages 7-39

A



Standard Global and BSP Dixon™, Hastelloy®, Vent-Lock™, King Crimp™ EZ Boss-Lock™, DIN Specification, EZ Boss-Lock™, EZLink™, 150# Flange, Reducing Adaptors & Couplers, Spool Adaptors and Couplers, Elbows, Gaskets

## INDUSTRIAL HOSE FITTINGS

Pages 40-135

B



Air King™, European Compressor, Smooth Tails, Storz Fittings, King™ Safety, Brass Fittings, Boss LPS, Hammer Unions, Swivel Joints, Spray Guns, ADS Outalarms, Combination Nipples, Strainers, Agri-Lock Bauer Couplings, Boss Fittings, Ground Joints, Crimp Sleeves, Ferrules, King Crimp™, Holedall™

## CLAMPS

Pages 136-150

C



Double Ear Clamps, Service Kit, Clamp Tools, Worm Gear, Clamp Liners, Super Clamps, K-Series, F-Series, Ultra-Lok®, Band & Buckle, Minsup™ Claw, Chain Restrainer, Double Bolt, 4-Bolt Type, Air King™, Saddle Clamp, Safety Clamps, Spiral Clamps

## DRY DISCONNECT FITTINGS

Pages 151-165

D



Safety Break-Away Couplings, Dry Quick Disconnect Adaptors and Couplers, Dry Aviation, Dry Gas, Dry Break Cam & Groove Adaptors and Couplers, Bayonet Style

## HYDRAULIC & PNEUMATIC QUICK DISCONNECTS

Pages 166-257

E



J-Series, N-Series, P-Series, NK-Series, DF-Series, H-Series, HS-Series, K-Series, W-Series, WS-Series, VEP-Series, HT-Series, HTE-Series, ST-Series, AG-Series, T-Series, TR-Series, E-Series, V-Series, CVV-Series, PD-Series

## PIPE, PIPE FITTINGS & WELDING

Pages 258-266



Quick Release Couplings, Standard Couplings, Lightweight Flexible Couplings, Lite® Couplings, Rigid Couplings, Grooved Clamps, Grooved Gaskets

F

## VALVES

Pages 267-295



Ball, Gate, Butterfly, Safety Check, Check, Globe, Needle, Relief, Strainers

G

## MARINE

Pages 296-302



Strainers, BISO, SISO, Inlet Scoop, Thru Hull Skin Fittings, Mounting Brackets, Replacement Parts

H

## HOSE

Pages 303-306



Hose Range and Hose Assemblies, Metallic, PTFE, Rubber, Composite, Spiral PVC, Hand Built, Specialist and Bespoke

I

## SAFETY & TECHNICAL

Pages 307-380



*Information contained in this catalogue is true and accurate as of the date of printing and may be subject to change.*

J

Force Chart, Technical Information - Hose, Fittings, Clamps, Threads, Pipe, Valves, Chemical, Steam, Pressure & Force, Conversions, Formula, Crimp Recommendations



+44 (0)1772 323529  
europe.dixonvalve.com

sale@technobearing.ru

TECHNOBEARING.RU

DGEL2020

8 (800) 700-72-07

1

A

B

C

D

E

F

G

H

I

J

K

# OUR PATH TO UNCOMMON EXCELLENCE

## MISSION TO DELIGHT

*Working together to delight our customers and generate profit.*

## VISION FOR TODAY AND TOMORROW

- Lead in our chosen markets by setting and achieving ambitious goals.
- Provide quality products, rapid delivery, and superior customer service worldwide.
- Encourage and assist all employees to reach their full potential with opportunities to influence the decision making process.
- Be accountable for executing our plans.



“As long as we focus on people, product and service, everything else will fall into place and we will achieve **Uncommon Excellence.**” - R.L. Goodall, CEO



ENDURING  
VALUES  
SINCE  
1916

RESPECT  
CITIZENSHIP  
RESPONSIBILITY  
CARING  
FAIRNESS  
TRUSTWORTHINESS



+44 (0)1772 323529  
europe.dixonvalve.com

sale@technobearing.ru

TECHNOBEARING.RU

DGEL2020  
8 (800) 700-72-07

# COMMITTED & CONNECTED

Dixon Europe is a premier manufacturer and supplier of material transfer products across a wide range of markets – construction, oil & gas, agriculture, food & beverage, petrochemical, civil engineering, and construction.

Dixon™ is committed to being the easiest company to do business with and has an unsurpassed reputation for producing safe and leak-free products for more than a century.

Headquartered in Chestertown, Maryland, in the United States of America, Dixon™ has grown to be a leading innovator and solutions provider in the hose coupling industry.

Dixon™ was founded in 1916 by Howard W. Goodall who visited construction sites, identified companies' hose and coupling requirements, and started manufacturing purpose-built product solutions.

Dixon Europe is proud to be a specialist supplier of industrial hose and hose assemblies; certified to the Pressure Equipment Directive 2014/68/EU to manufacture flexible hose assemblies positioning Dixon™ as a market leader in this field.

With sales and distribution in the UK, Germany, France, Russia and the Middle East and with manufacturing and engineering facilities approved to BSI ISO 9001, Dixon Europe utilises its application-based knowledge and current technologies to create products that solve challenges across a wide range of material transfer applications.

Dixon Europe is driven to provide 'the right connection' in meeting specific hose and coupling requirements across all industries. Their strength in service, technical support, training, and advice ensure the correct specification of bespoke hose assemblies and couplings.



# A RELIABLE DISTRIBUTION FOOTPRINT

Products are often needed at a moment's notice. That is why Dixon™ has a wide distribution footprint across borders.

Real-time inventory control and years of tracking demand allows the right goods to be dispatched and to arrive at the right time.



## Real solutions for real challenges



# VALUE ADD CENTRES

Dixon™ has value add centres in multiple locations where customers have access to made-to-order hose assemblies, actuated valves, and bespoke fittings for a wide variety of material transfer applications.

Hose assemblies can be tested and certified and feature Dixon™ hose, couplings, clamps and ferrules providing a fully integrated and safe Dixon™ assembly.

Valves and fabrications can be designed, machined, and welded to meet customers requirements



# WORLD-CLASS CUSTOMER SERVICE

As Dixon Europe we are driven to provide 'the right connection' in meeting specific hose and coupling requirements across all industries. Our strength in service, technical support, training, and advice ensure the correct specification of bespoke hose assemblies and couplings.

Dixon™ products are reliable. Quality control starts at the innovative stage and is further supported with technologically advanced engineering and manufacturing processes. Dixon™ will not compromise on high quality control, utilising assurance standards and inspection procedures at each critical step of the production process.

- ISO: 9001
- Pressure Equipment Directive 2014/68/EU
- DNV GL Type Approval







Standard Global and BSP Dixon™	9-14
Hastelloy®	15
Vent-Lock™	16
King Crimp™ EZ Boss-Lock™	17
DIN Specification	18-19
EZ Boss-Lock™	20-23
EZLink™	24-25
150# Flange	26
Reducing Adaptors & Couplers	27-28
Spool Adaptors & Couplers	29
Elbows	30-32
Gaskets	33-35
Accessories	36-39



## Specifications

### Design Information



#### Applications

The Dixon™ cam & groove coupling is a reliable quick connect coupling for use on hose, pipe, tubing, and tanks conveying a wide variety of liquids, dry bulk materials, and vapours, including cooling water, fuels, chemicals, cosmetics, food products, adhesives, dyes, pharmaceuticals, pellets, and much more.

#### How does it work?

1. To make connection, slide the adaptor into the coupler and with normal hand pressure, press the cam levers down.
2. Uncoupling is as quick and simple as coupling. Just lift the cam arms and remove the adaptor.

The Dixon™ range of cam & groove (Camlock) couplers and adaptors are manufactured to interchange with all product produced to Commercial Item Description A-A 59326D, which supersedes Mil-C-27487. No standard exists for the ½" (15mm), 5" (125mm) and 8" (200mm) fittings, and generally these sizes do not interchange with other manufacturers.

### Pressure Ratings

**Designed for use with liquids.** Consult Dixon™ for specific recommendations. Recommendations based on the use of mating Dixon™ fittings at ambient temperature 21°C with standard Buna-N seal installed. For use at elevated temperature or other unusual operating conditions, consult your Dixon™ representative.

#### For Aluminium, Bronze, Brass, Stainless Steel & Malleable Camlocks:

Sizes (mm)	15	20-50	65	75	100	125-150	200
Pressure (PSI)	<b>150</b>	<b>250</b>	<b>150</b>	<b>125</b>	<b>100</b>	<b>75</b>	<b>50</b>
Working Pressure (PSI) with King Crimp™ Ferrule System	<b>150</b>	<b>250</b>	<b>150</b>	<b>150</b>	<b>150</b>	<b>75</b>	<b>50</b>

#### For Polypropylene and Nyglass camlocks:

Sizes (mm)	15-25	32-50	75	100
Pressure (PSI)	<b>125</b>	<b>100</b>	<b>60</b>	<b>50</b>

### Materials

The Dixon™ range of cam & groove (Camlock) couplers and adaptors are manufactured from the following materials:

- Aluminium conforming to the requirements of ASTM B26/B26M Grade 356.0 – T6
- Stainless Steel grade CF8M (316 Equivalent) in accordance with the requirements of ASTM-A351
- Bronze grade UNS C84400 in accordance with the requirements of ASTM-B584
- Polypropylene 30% glass filled
- Nyglass 30% glass filled

Body	Levers	Pins	Pull Rings
Die Cast Aluminium	Brass	Zinc Plated Steel	Zinc Plated Steel
Brass	210 Stainless Steel	Zinc Plated Steel	Zinc Plated Steel
Bronze	210 Stainless Steel	Zinc Plated Steel	Zinc Plated Steel
Polypropylene	210 Stainless Steel	Zinc Plated Steel	Zinc Plated Steel
Nyglass	210 Stainless Steel	Zinc Plated Steel	Zinc Plated Steel
Stainless Steel 15mm - 25mm	210 Stainless Steel	303 Stainless Steel	316 Stainless Steel
Stainless Steel 32mm - 150mm	210 Stainless Steel	303 Stainless Steel	316 Stainless Steel

### Welding of Camlocks

**Couplings made using the die cast process must NOT be welded.** Although Bronze Sand Cast Couplings made from the above materials may be welded using the appropriate welding equipment and compatible filler material, any modifications to the product will void your warranty. Welding the couplings changes the integrity of the coupling, therefore Dixon™ will not accept any responsibility for modified couplings.



#### Camlock Safety

- **UNDER NO CIRCUMSTANCES** should cam & groove (camlock) couplings be used in compressed air or steam applications.
- Dust caps and dust plugs are not to be used in any pressure applications, for safety and environmental reasons.

**A**

## Standard Global Dixon™ Type A

Male Adaptor x Female						
Size (mm)	Aluminium (Brass Handles)		Brass (Forged)		316 Stainless Steel	
	NPT Part No.	BSP Part No.	NPT Part No.	BSP Part No.	NPT Part No.	BSP Part No.
13	G50-A-AL	G50-A-ALB	G50-A-BR	G50-A-BRB	G50-A-SS	G50-A-SSB
20	G75-A-AL	G75-A-ALB	G75-A-BR	G75-A-BRB	G75-A-SS	G75-A-SSB
25	G100-A-AL	G100-A-ALB	G100-A-BR	G100-A-BRB	G100-A-SS	G100-A-SSB
32	G125-A-AL	G125-A-ALB	G125-A-BR	G125-A-BRB	G125-A-SS	G125-A-SSB
40	G150-A-AL	G150-A-ALB	G150-A-BR	G150-A-BRB	G150-A-SS	G150-A-SSB
50	G200-A-AL	G200-A-ALB	G200-A-BR	G200-A-BRB	G200-A-SS	G200-A-SSB
65	G250-A-AL	G250-A-ALB	G250-A-BR	G250-A-BRB	G250-A-SS	G250-A-SSB
75	G300-A-AL	G300-A-ALB	G300-A-BR	G300-A-BRB	G300-A-SS	G300-A-SSB
100	G400-A-AL	G400-A-ALB	G400-A-BR	G400-A-BRB	G400-A-SS	G400-A-SSB
125	G500-A-AL	G500-A-ALB	G500-A-BR	G500-A-BRB	-	-
150	G600-A-AL	G600-A-ALB	-	-	G600-A-SS	G600-A-SSB
200	G800-A-AL	G800-A-ALB	-	-	-	-



aluminium



brass (forged)



316 stainless steel

## Standard Global Dixon™ Type B

Female Coupler x Male Thread						
Size (mm)	Aluminium (Brass Handles)		Brass (Forged)		316 Stainless Steel	
	NPT Part No.	BSP Part No.	NPT Part No.	BSP Part No.	NPT Part No.	BSP Part No.
13	G50-B-AL	G50-B-ALB	G50-B-BR	G50-B-BRB	G50-B-SS	G50-B-SSB
20	G75-B-AL	G75-B-ALB	G75-B-BR	G75-B-BRB	G75-B-SS	G75-B-SSB
25	G100-B-AL	G100-B-ALB	G100-B-BR	G100-B-BRB	G100-B-SS	G100-B-SSB
32	G125-B-AL	G125-B-ALB	G125-B-BR	G125-B-BRB	G125-B-SS	G125-B-SSB
40	G150-B-AL	G150-B-ALB	G150-B-BR	G150-B-BRB	G150-B-SS	G150-B-SSB
50	G200-B-AL	G200-B-ALB	G200-B-BR	G200-B-BRB	G200-B-SS	G200-B-SSB
65	G250-B-AL	G250-B-ALB	G250-B-BR	G250-B-BRB	G250-B-SS	G250-B-SSB
75	G300-B-AL	G300-B-ALB	G300-B-BR	G300-B-BRB	G300-B-SS	G300-B-SSB
100	G400-B-AL	G400-B-ALB	G400-B-BR	G400-B-BRB	G400-B-SS	G400-B-SSB
125	G500-B-AL	G500-B-ALB	G500-B-BR	G500-B-BRB	-	-
150	G600-B-AL	G600-B-ALB	-	-	G600-B-SS	G600-B-SSB



aluminium



brass (forged)



316 stainless steel

**For technical, application, and material guidelines, please refer to page 8**

A

## Standard Global Dixon™ Type C



aluminium



stainless steel



brass

Female Coupler x Hose Shank				
Size (mm)	Max WP PSI	Aluminium	Stainless Steel	Brass
		Part No.	Part No.	Part No.
15	150	G50-C-AL	G50-C-SS	G50-C-BR
20	250	G75-C-AL	G75-C-SS	G75-C-BR
25	250	G100-C-AL	G100-C-SS	G100-C-BR
32	250	G125-C-AL	G125-C-SS	G125-C-BR
40	250	G150-C-AL	G150-C-SS	G150-C-BR
50	250	G200-C-AL	G200-C-SS	G200-C-BR
65	150	G250-C-AL	G250-C-SS	G250-C-BR
75	125	G300-C-AL	G300-C-SS	G300-C-BR
100	100	G400-C-AL	G400-C-SS	G400-C-BR
125	75	G500-C-AL	-	G500-C-BR
150	75	G600-C-AL	G600-C-SS	-
203	75	G800-C-AL	-	-

## Standard Global Dixon™ Type D



aluminium



brass (forged)



316 stainless steel

Female Coupler x Female Thread						
Size (mm)	Aluminium (Brass Handles)		Brass (Forged)		316 Stainless Steel	
	NPT Part No.	BSP Part No.	NPT Part No.	BSP Part No.	NPT Part No.	BSP Part No.
13	G50-D-AL	G50-D-ALB	G50-D-BR	G50-D-BRB	G50-D-SS	G50-D-SSB
20	G75-D-AL	G75-D-ALB	G75-D-BR	G75-D-BRB	G75-D-SS	G75-D-SSB
25	G100-D-AL	G100-D-ALB	G100-D-BR	G100-D-BRB	G100-D-SS	G100-D-SSB
32	G125-D-AL	G125-D-ALB	G125-D-BR	G125-D-BRB	G125-D-SS	G125-D-SSB
40	G150-D-AL	G150-D-ALB	G150-D-BR	G150-D-BRB	G150-D-SS	G150-D-SSB
50	G200-D-AL	G200-D-ALB	G200-D-BR	G200-D-BRB	G200-D-SS	G200-D-SSB
65	G250-D-AL	G250-D-ALB	G250-D-BR	G250-D-BRB	G250-D-SS	G250-D-SSB
75	G300-D-AL	G300-D-ALB	G300-D-BR	G300-D-BRB	G300-D-SS	G300-D-SSB
100	G400-D-AL	G400-D-ALB	G400-D-BR	G400-D-BRB	G400-D-SS	G400-D-SSB
125	G500-D-AL	G500-D-ALB	G500-D-BR	G500-D-BRB	-	-
150	G600-D-AL	G600-D-ALB	-	-	G600-D-SS	G600-D-SSB

For technical, application, and material guidelines, please refer to page 8



A

## Standard Global Dixon™ Type E

Male Adaptor x Hose Shank				
Size (mm)	Max WP PSI	Aluminium	Stainless Steel	Brass
		Part No.	Part No.	Part No.
15	150	G50-E-AL	G50-E-SS	G50-E-BR
20	250	G75-E-AL	G75-E-SS	G75-E-BR
25	250	G100-E-AL	G100-E-SS	G100-E-BR
32	250	G125-E-AL	G125-E-SS	G125-E-BR
40	250	G150-E-AL	G150-E-SS	G150-E-BR
50	250	G200-E-AL	G200-E-SS	G200-E-BR
65	150	G250-E-AL	G250-E-SS	G250-E-BR
75	125	G300-E-AL	G300-E-SS	G300-E-BR
100	100	G400-E-AL	G400-E-SS	G400-E-BR
125	75	G500-E-AL	-	G500-E-BR
150	75	G600-E-AL	G600-E-SS	-
250	75	G800-E-AL	-	-



aluminium



stainless steel



brass

## Standard Global Dixon™ Type F

Male Adaptor x Male Thread						
Size (mm)	Aluminium (Brass Handles)		Brass (Forged)		316 Stainless Steel	
	NPT Part No.	BSP Part No.	NPT Part No.	BSP Part No.	NPT Part No.	BSP Part No.
13	G50-F-AL	G50-F-ALB	G50-F-BR	G50-F-BRB	G50-F-SS	G50-F-SSB
20	G75-F-AL	G75-F-ALB	G75-F-BR	G75-F-BRB	G75-F-SS	G75-F-SSB
25	G100-F-AL	G100-F-ALB	G100-F-BR	G100-F-BRB	G100-F-SS	G100-F-SSB
32	G125-F-AL	G125-F-ALB	G125-F-BR	G125-F-BRB	G125-F-SS	G125-F-SSB
40	G150-F-AL	G150-F-ALB	G150-F-BR	G150-F-BRB	G150-F-SS	G150-F-SSB
50	G200-F-AL	G200-F-ALB	G200-F-BR	G200-F-BRB	G200-F-SS	G200-F-SSB
65	G250-F-AL	G250-F-ALB	G250-F-BR	G250-F-BRB	G250-F-SS	G250-F-SSB
75	G300-F-AL	G300-F-ALB	G300-F-BR	G300-F-BRB	G300-F-SS	G300-F-SSB
100	G400-F-AL	G400-F-ALB	G400-F-BR	G400-F-BRB	G400-F-SS	G400-F-SSB
125	G500-F-AL	G500-F-ALB	G500-F-BR	G500-F-BRB	-	-
150	G600-F-AL	G600-F-ALB	-	-	G600-F-SS	G600-F-SSB



aluminium



brass (forged)



316 stainless steel

For technical, application, and material guidelines, please refer to page 8

# Cam & Groove

A

## Standard Global Dixon™ Type DC



aluminium



stainless steel



brass

Dust Cap			
Size (mm)	Aluminium	Stainless Steel	Brass
	Part No.	Part No.	Part No.
15	G50-DC-AL	G50-DC-SS	G50-DC-BR
20	G75-DC-AL	G75-DC-SS	G75-DC-BR
25	G100-DC-AL	G100-DC-SS	G100-DC-BR
32	G125-DC-AL	G125-DC-SS	G125-DC-BR
40	G150-DC-AL	G150-DC-SS	G150-DC-BR
50	G200-DC-AL	G200-DC-SS	G200-DC-BR
65	G250-DC-AL	G250-DC-SS	G250-DC-BR
75	G300-DC-AL	G300-DC-SS	G300-DC-BR
100	G400-DC-AL	G400-DC-SS	G400-DC-BR
125	G500-DC-AL	-	G500-DC-BR
150	G600-DC-AL	G600-DC-SS	-



Dust Caps are NOT to be used in pressure applications, for safety and environmental reasons.

## Standard Global Dixon™ Type DP



aluminium



stainless steel



brass

Dust Plug			
Size (mm)	Aluminium	Stainless Steel	Brass
	Part No.	Part No.	Part No.
15	G50-DP-AL	G50-DP-SS	G50-DP-BR
20	G75-DP-AL	G75-DP-SS	G75-DP-BR
25	G100-DP-AL	G100-DP-SS	G100-DP-BR
32	G125-DP-AL	G125-DP-SS	G125-DP-BR
40	G150-DP-AL	G150-DP-SS	G150-DP-BR
50	G200-DP-AL	G200-DP-SS	G200-DP-BR
65	G250-DP-AL	G250-DP-SS	G250-DP-BR
75	G300-DP-AL	G300-DP-SS	G300-DP-BR
100	G400-DP-AL	G400-DP-SS	G400-DP-BR
125	G500-DP-AL	-	G500-DP-BR
150	G600-DP-AL	G600-DP-SS	-



Dust Caps are NOT to be used in pressure applications, for safety and environmental reasons.

For technical, application, and material guidelines, please refer to page 8



A

## Standard BSP Dixon™ Type A

Size (mm)	Max WP* (PSI) @ Temp			Polypropylene
	-18	21	65	
				Part No.
15	100	125	70	PPA050B
20	100	125	70	PPA075B
25	100	125	70	PPA100B
32	100	125	70	PPA125B
40	100	125	70	PPA150B
50	100	125	70	PPA200B
75	70	90	50	PPA300B
100	70	90	50	PPA400B



## Standard BSP Dixon™ Type B

Size (mm)	Max WP* (PSI) @ Temp			Polypropylene
	-18	21	65	
				Part No.
15	100	125	70	PPB050B
20	100	125	70	PPB075B
25	100	125	70	PPB100B
32	100	125	70	PPB125B
40	100	125	70	PPB150B
50	100	125	70	PPB200B
75	70	90	50	PPB300B
100	70	90	50	PPB400B



## Standard Dixon™ Type C

Size (mm)	Max WP* (PSI) @ Temp			Polypropylene
	-18	21	65	
				Part No.
15	100	125	70	PPC050B
20	100	125	70	PPC075B
25	100	125	70	PPC100B
32	100	125	70	PPC125B
40	100	125	70	PPC150B
50	100	125	70	PPC200B
75	70	90	50	PPC300B
100	70	90	50	PPC400B



## Standard BSP Dixon™ Type D

Size (mm)	Max WP* (PSI) @ Temp			Polypropylene
	-18	21	65	
				Part No.
15	100	125	70	PPD050B
20	100	125	70	PPD075B
25	100	125	70	PPD100B
32	100	125	70	PPD125B
40	100	125	70	PPD150B
50	100	125	70	PPD200B
75	70	90	50	PPD300B
100	70	90	50	PPD400B



All above products are available in NPT.  
All above products are available in Nyglass.

- The coupler and adaptor portions of the 15mm size use the 20mm standard body size
- Polypropylene and Nyglass cam & groove should not be mixed with aluminium fittings

**For technical, application, and material guidelines, please refer to page 8**

# Cam & Groove

## Dixon™ Type E



Size (mm)	Max WP* (PSI) @ Temp			Polypropylene	
	-18	21	65	Part No.	
15	100	125	70	PPE050B	
20	100	125	70	PPE075B	
25	100	125	70	PPE100B	
32	100	125	70	PPE125B	
40	100	125	70	PPE150B	
50	100	125	70	PPE200B	
75	70	90	50	PPE300B	
100	70	90	50	PPE400B	

## Standard BSP Dixon™ Type F



Size (mm)	Max WP* (PSI) @ Temp			Polypropylene	
	-18	21	65	Part No.	
15	100	125	70	PPF050B	
20	100	125	70	PPF075B	
25	100	125	70	PPF100B	
32	100	125	70	PPF125B	
40	100	125	70	PPF150B	
50	100	125	70	PPF200B	
75	70	90	50	PPF300B	
100	70	90	50	PPF400B	

## Dixon™ Type DC



Size (mm)	Polypropylene	
	Part No.	
20	PPH075B	
25	PPH100B	
32	PPH125B	
40	PPH150B	
50	PPH200B	
75	PPH300B	
100	PPH400B	

## Dixon™ Type DP



Size (mm)	Polypropylene	
	Part No.	
20	PPP075B	
25	PPP100B	
32	PPP125B	
40	PPP150B	
50	PPP200B	
75	PPP300B	
100	PPP400B	

All above products are available in NPT.  
All above products are available in Nyglass.



- The coupler and adaptor portions of the 15mm size use the 20mm standard body size
- Polypropylene and Nyglass cam & groove should not be mixed with aluminium fittings
- Dust Caps & Plugs are **NOT** to be used in pressure applications, for safety & applications

For technical, application, and material guidelines, please refer to page 8



A

## Hastelloy® Adaptors

Size (mm)	Hastelloy® CW12MW Type A
	Part No.
25	100-A-HA
40	150-A-HA
50	200-A-HA
75	300-A-HA



female NPT x male adaptor

Size (mm)	Hastelloy® CW12MW Type F
	Part No.
25	100-F-HA
40	150-F-HA
50	200-F-HA
75	300-F-HA



male NPT x male adaptor

Size (mm)	Hastelloy® CW12MW Type E
	Part No.
25	100-E-HA
40	150-E-HA
50	200-E-HA
75	300-E-HA



male adaptor x hose shank

## Hastelloy® Couplers

<b>Features:</b>	<ul style="list-style-type: none"> <li>• Couplers supplied with FKM gaskets</li> <li>• 316 stainless steel cam arms</li> <li>• 302 stainless steel pins</li> <li>• Yellow zinc plated, 12-gauge steel wire rings</li> </ul>
------------------	---

Size (mm)	Hastelloy® CW12MW Type C
	Part No.
25	HAC100EZ
40	HAC150EZ
50	HAC200EZ
75	HAC300EZ



female coupler x hose shank

Size (mm)	Hastelloy® CW12MW Type D
	Part No.
25	HAD100EZ
40	HAD150EZ
50	HAD200EZ
75	HAD300EZ



female coupler x female NPT

Size (mm)	Hastelloy® CW12MW Type B
	Part No.
25	HAB100EZ
40	HAB150EZ
50	HAB200EZ
75	HAB300EZ



female coupler x male NPT

## Vent-Lock™ (Safety Cam & Groove) Couplings



Type A



Type C



Type E



Type DC



Type DP

<b>Application:</b>	<ul style="list-style-type: none"> <li>Transfer of fluids and solids with a safer disconnection</li> </ul>
<b>Features:</b>	<ul style="list-style-type: none"> <li>Safety release cam &amp; groove couplings permit the release of static pressure when disconnecting hose assemblies</li> <li>Venting system protects operator from being sprayed with hazardous or non-hazardous fluids or solids</li> <li>Rated to <b>250 PSI</b>, recommendation based on the use of mating Dixon™ Vent-Lock™ fittings at ambient temperature (<b>21°C</b>) with standard Buna-N seal installed, for use at elevated temperature or other unusual operating conditions, consult Dixon™</li> <li>Safety orange powder coated cam arms</li> <li>Does not interchange with standard</li> </ul>
<b>Material:</b>	<ul style="list-style-type: none"> <li>316 stainless steel</li> <li>Consult Dixon™ for availability of other materials</li> </ul>
<b>Attachment</b>	<ul style="list-style-type: none"> <li>Ferrules, sleeves, bands, and other reliable options</li> </ul>

316 Stainless Steel					
Size (inch)	Type A	Type C <sup>1</sup>	Type E	Type DC <sup>1</sup>	Type DP
	Part No.	Part No.	Part No.	Part No.	Part No.
1	L100-A-SS	L100-C-SS	L100-E-SS	L100-DC-SS	L100-DP-SS
1½	L150-A-SS	L150-C-SS	L150-E-SS	L150-DC-SS	L150-DP-SS
2	L200-A-SS	L200-C-SS	L200-E-SS	L200-DC-SS	L200-DP-SS
3	L300-A-SS	---	L300-E-SS	---	L300-DP-SS

<sup>1</sup> Vent-Lock™ inventory will feature safety orange powder coated cam arms. Refer to crimp ferrules on pages 116 - 117.

## Vent-Lock™ Safety EZ Boss-Lock™ Cam & Groove Couplings



Type C

Type D



Type H

316 Stainless Steel			
Size (inch)	Type C	Type D	Type H
	Part No.	Part No.	Part No.
1	RLC100EZ	RLD100EZ	RLH100EZ
1½	RLC150EZ	RLD150EZ	RLH150EZ
2	RLC200EZ	RLD200EZ	RLH200EZ
3	RLC300EZ <sup>1</sup>	---	RLH300EZ

<sup>1</sup> Hose drop shank

## Vent-Lock™ Safety Accessories



Dixon™

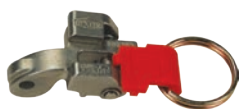

EZ Boss-Lock™

316 Stainless Steel		
Size (inch)	Dixon™ handle / ring / pin	EZ Boss-Lock™ handle / ring / pin
	Part No.	Part No.
1	L100-HSCRPI-SI	LRHEZ175
1½	L200-HSCRPI-SI	LRHEZ152
2	---	LRHEZ34

## King Crimp™ EZ Boss-Lock™ Cam & Groove Type C

A

- Features:**
- Couplers are supplied standard with a Buna-N gasket. Other gasket types are available, refer to pages 33-35

Female Coupler x Hose Shank	
Hose ID (inch)	316 Stainless Steel Part No.
1	RC100EZCR
1½	RC150EZCR
2	RC200EZCR
3	RC300EZCR
4	RC400EZCR
6	RC600EZCR



**!** Under no circumstances should the EZ Boss-Lock™ cam arms be used on any fittings not specifically designed for their use. Refer to pages 20 & 36 for further specifications.

## Cam & Groove Type C

- Features:**
- All couplers are supplied with safety clips
  - Couplers are supplied standard with a Buna-N gasket. Other gasket types are available, refer to pages 33 - 35

Female Coupler x Hose Shank			
Hose ID (inch)	A380 Permanent Mould Aluminium	ASTMC 3800 Forged Brass	316 Investment Cast Stainless Steel
	Part No.	Part No.	Part No.
1	G100-C-ALCR	G100-C-BRCR	G100-C-SSCR
1½	G150-C-ALCR	G150-C-BRCR	G150-C-SSCR
2	G200-C-ALCR	G200-C-BRCR	G200-C-SSCR
3	G300-C-ALCR	G300-C-BRCR	G300-C-SSCR
4	G400-C-ALCR	G400-C-BRCR	G400-C-SSCR
6	G600-C-ALCR	-	G600-C-SSCR



## Cam & Groove Type E

Male Adaptor x Hose Shank			
Hose ID (inch)	A380 Permanent Mould Aluminium	ASTMC 3800 Forged Brass	316 Investment Cast Stainless Steel
	Part No.	Part No.	Part No.
1	G100-E-ALCR	G100-E-BRCR	G100-E-SSCR
1½	G150-E-ALCR	G150-E-BRCR	G150-E-SSCR
2	G200-E-ALCR	G200-E-BRCR	G200-E-SSCR
3	G300-E-ALCR	G300-E-BRCR	G300-E-SSCR
4	G400-E-ALCR	G400-E-BRCR	G400-E-SSCR
6	G600-E-ALCR	G600-E-BRCR	G600-E-SSCR



- Refer to crimp sleeves and ferrules on pages 114-117

**!** Only use the crimp-style shanks with the crimp-style sleeves and ferrules. Due to differences in dimensions and tolerances for safety reasons, DO NOT interchange other manufacturers' products with Dixon™ products.

# Cam & Groove

A

## DIN Specification BSP BS EN 14420 - Type A



stainless steel

Size (DIN)	Stainless Steel	Brass
	Part No.	Part No.
DN20	75ASSDIN	75ABRDIN
DN25	100ASSDIN	100ABRDIN
DN32	125ASSDIN	125ABRDIN
DN40	150ASSDIN	150ABRDIN
DN50	200ASSDIN	200ABRDIN
DN65	250ASSDIN	250ABRDIN
DN80	300ASSDIN	300ABRDIN
DN100	400ASSDIN	400ABRDIN

## DIN Specification Smooth Tail With Collar BS EN 14420 - Type C



stainless steel

Size (DIN)	Aluminium	Stainless Steel	Brass	Polypropylene
	Part No.	Part No.	Part No.	Part No.
DN20	75CALDIN	75CSSDIN	75CBRDIN	-
DN25	100CALDIN	100CSSDIN	100CBRDIN	100CPPDIN
DN32	125CALDIN	125CSSDIN	125CBRDIN	-
DN40	150CALDIN	150CSSDIN	150CBRDIN	-
DN50	200CALDIN	200CSSDIN	200CBRDIN	200CPPDIN

## DIN Specification BSP BS EN 14420 - Type D



stainless steel

Size (DIN)	Stainless Steel	Brass
	Part No.	Part No.
DN20	75DSSDIN	75DBRDIN
DN25	100DSSDIN	100DBRDIN
DN32	125DSSDIN	125DBRDIN
DN40	150DSSDIN	150DBRDIN
DN50	200DSSDIN	200DBRDIN
DN65	250DSSDIN	250DBRDIN
DN80	300DSSDIN	300DBRDIN
DN100	400DSSDIN	400DBRDIN

## DIN Specification Smooth Tail With Collar BS EN 14420 - Type E



stainless steel

Size (DIN)	Aluminium	Stainless Steel	Brass	Polypropylene
	Part No.	Part No.	Part No.	Part No.
DN20	75EALDIN	75ESSDIN	75EBRDIN	-
DN25	100EALDIN	100ESSDIN	100EBRDIN	100EPPDIN
DN32	125EALDIN	125ESSDIN	125EBRDIN	-
DN40	150EALDIN	150ESSDIN	150EBRDIN	-
DN50	200EALDIN	200ESSDIN	200EBRDIN	200EPPDIN

## DIN Specification EZ Boss-Lock BS EN 14420

Size (DIN)	Stainless Steel	
	Part No.	
DN25	RD100 DIN EZ	
DN40	RD150 DIN EZ	
DN50	RD200 DIN EZ	
DN80	RD300 DIN EZ	
DN100	RD400 DIN EZ	

- Available to special order only.



A

## ***EZ Boss-Lock™ offers several unique features.***

- No more fumbling with clamps, wire, clips, or pins. Just close the handles and the locking mechanism is engaged.
- Extremely easy to open, the ergonomic release lever is under your thumb when you want to open the fitting.
- Resistant to accidental disconnection when being dragged; the release lever opens in the direction opposite to the cam arm, so movements that can open the release lever also can close the cam arm.
- If the rotating lever is not flush with the handle, it is not properly engaged.
- No sliding pins to jam or pop open.
- Rotating action helps keep the locking device free of debris.
- Rugged design protects critical parts from impact.
- Can be supplied with custom shanks, also available with swaged and pf shanks for hard-to-couple chemical hoses.
- Assemblies are investment cast stainless steel with plated carbon steel pull rings.
- Small OD makes it easy to insert into the hose tubes on tank trucks and to use in restricted spaces.
- Assemblies can be retrofitted onto undamaged stainless-steel Boss-Lock™ allowing you to protect your investment in stainless steel Boss-Lock™ couplings while you upgrade.
- EZ Boss-Lock™ investment stainless-steel cam arms are guaranteed! Should you break one, return it to the nearest warehouse for a free replacement.



## EZ Boss-Lock™ Dixon™ Type B

Female Coupler x Male Thread					
Size (mm)	Max WP* PSI	Stainless Steel BSP	Stainless Steel NPT	Aluminium NPT	Brass NPT
		Part No.	Part No.	Part No.	Part No.
15	150	RB050EZA	RB050EZ	-	-
20	250	RB075EZA	RB075EZ	-	BB075EZ
25	250	RB100EZA	RB100EZ	-	BB100EZ
32	250	RB125EZA	RB125EZ	-	-
40	250	RB150EZA	RB150EZ	AB150EZ	BB150EZ
50	250	RB200EZA	RB200EZ	AB200EZ	BB200EZ
75	125	RB300EZA	RB300EZ	AB300EZ	BB300EZ
100	100	RB400EZA	RB400EZ	AB400EZ	BB400EZ
150	75	RB600EZA	RB600EZ	-	-



A

## EZ Boss-Lock™ Dixon™ Type C

Female Coupler x Hose Tail				
Size (mm)	Max WP* PSI	Stainless Steel	Aluminium	Brass
		Part No.	Part No.	Part No.
15	150	RC050EZ	-	-
20	250	RC075EZ	-	BC075EZ
25	250	RC100EZ	AC100EZ	BC100EZ
32	250	RC125EZ	-	-
40	250	RC150EZ	AC150EZ	BC150EZ
50	250	RC200EZ	AC200EZ	BC200EZ
65	150	-	AC250EZ	-
75	125	RC300EZ	AC300EZ	BC300EZ
100	100	RC400EZ	AC400EZ	BC400EZ
150	75	RC600EZ	AC600EZ	-



## EZ Boss-Lock™ Dixon™ Type D

Female Coupler x Female Thread					
Size (mm)	Max WP* PSI	Stainless Steel BSP	Stainless Steel NPT	Aluminium NPT	Brass NPT
		Part No.	Part No.	Part No.	Part No.
15	150	RD050EZA	RD050EZ	-	-
20	250	RD075EZA	RD075EZ	-	BD075EZ
25	250	RD100EZA	RD100EZ	AD100EZ	BD100EZ
32	250	RD125EZA	RD125EZ	-	BD125EZ
40	250	RD150EZA	RD150EZ	AD150EZ	BD150EZ
50	250	RD200EZA	RD200EZ	AD200EZ	BD200EZ
65	150	-	-	AD250EZ	BD250EZ
75	125	RD300EZA	RD300EZ	AD300EZ	BD300EZ
100	100	RD400EZA	RD400EZ	AD400EZ	BD400EZ
125	75	-	-	AD500EZ	-
150	75	-	RD600EZ	AD600EZ	-



## EZ Boss-Lock Dixon™ Type DC

Dust Cap			
Size (mm)	Stainless Steel	Aluminium	Brass
	Part No.	Part No.	Part No.
20	RH075EZ	-	-
25	RH100EZ	-	-
32	RH125EZ	-	-
40	RH150EZ	AH150EZ	-
50	RH200EZ	AH200EZ	BH200EZ
65	-	AH250EZ	-
75	RH300EZ	AH300EZ	-
100	RH400EZ	AH400EZ	-
150	RH600EZ	AH600EZ	-



Plated/Unplated malleable iron, hastelloy, and aluminium hard coat are available on request  
 Note: ½" & ¾" have same ¾" body. Only the thread changes.

- Under no circumstances should the EZ Boss-Lock™ cam arms be used on any fitting not specifically produced for their use
- Dust Caps & Dust Plugs are **NOT** to be used in pressure applications for safety and environmental reasons

**For technical, application, and material guidelines, please refer to page 8**

## A EZ Boss-Lock™ Notched Type C

The largest advantage of the Notched EZ Boss-Lock™ design is that the coupling can be removed from a damaged hose by cutting away the ferrule, without necessarily damaging the fitting. After inspection to determine its suitability for reuse, it can be reinstalled into another hose by using a new ferrule.



Coupler x Hose Shank

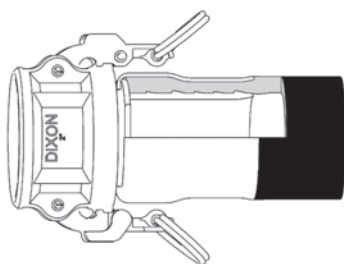

Swaged Assembly

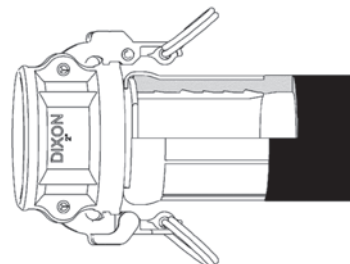

Crimped Assembly



Ferrule

Coupler x Hose Shank				
Size (mm)	Minimum Hose OD (mm)	Maximum Hose OD (mm)	Stainless Steel Part No.	Stainless Steel Notched Ferrule Part No.
40	49.21	55.56	RC150EZNO	GAS2334NO
40	52.39	59.53	RC150EZNO	GAS2370NO
50	62.71	68.26	RC200EZNO	GAS2709NO
50	67.47	72.23	RC200EZNO	GAS2885NO
75	88.11	94.46	RC300EZNO	GAS3760NO
75	94.85	97.63	RC300EZNO	GAS3885NO
100	117.48	120.25	RC400EZNO	GAS5010NO

## EZ Boss-Lock™ Notched Type E



Adaptor x Hose Shank



Swaged Assembly

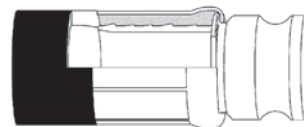

Crimped Assembly



Ferrule

Adaptor x Hose Shank				
Size (mm)	Minimum Hose OD (mm)	Maximum Hose OD (mm)	Stainless Steel Part No.	Stainless Steel Notched Ferrule Part No.
40	49.21	55.56	RE150EZNO	GAS2334NO
40	52.39	59.53	RE150EZNO	GAS2370NO
50	62.71	68.26	RE200EZNO	GAS2709NO
50	67.47	72.23	RE200EZNO	GAS2885NO
75	88.11	94.46	RE300EZNO	GAS3760NO
75	94.85	97.63	RE300EZNO	GAS3885NO
100	117.48	120.25	RE400EZNO	GAS5010NO



- The Notched EZ Boss-Lock™ system allows you to better manage your inventories. You can stock one coupling and two ferrules, and thereby cover the same hose range with less inventory. *You must purchase a fitting and the matching ferrule to create an assembly.*
- Dixon™ stems and ferrules are specifically designed to be used together as a coupling system. *Due to differences in dimensions and tolerances, for safety reasons do not use other manufacturers' stems or ferrules with Dixon™ Holedall™ products.*
- Contact Dixon™ for swage and crimp recommendations.

For technical, application, and material guidelines, please refer to page 8





## External Notched Stems & Ferrules

This stem can be removed from a damaged hose by cutting away the ferrule, without necessarily damaging the fitting. After inspection to determine its suitability for reuse, it can be reinstalled into another hose by using a new ferrule. You can now stock one nipple and two ferrules, and thereby cover the same hose range with less inventory. 316 stainless-steel stem with wrench flat, 304 stainless-steel ferrule. You must purchase a fitting and the matching ferrule to create an assembly. Can be swaged-on or crimped-on; consult Dixon™ for specifications.

- For hose OD of 52.4 and below, these couplings are crimp only
- For hose OD of 52.8 and above, these couplings can be crimped or swaged

Male NPT x Notched Shank				
Hose ID (mm)	Hose OD (mm)		Ferrule	Stem
	From:	To:	Part No.	Part No.
40	48.8	54.8	GAS2334NOS	RST150NOS
40	51.6	58.7	GAS2370NOS	RST150NOS
50	61.9	67.5	GAS2709NOS	RST200NOS
50	66.7	71.4	GAS2885NOS	RST200NOS
75	86.9	93.3	GAS3760NOS	RST300NOS
75	93.7	96.4	GAS3885NOS	RST300NOS



Male BSP x Notched Shank				
Hose ID (mm)	Hose OD (mm)		Ferrule	Stem
	From:	To:	Part No.	Part No.
40	48.8	54.8	GAS2334NOS	RST150NOSA
40	51.6	58.7	GAS2370NOS	RST150NOSA
50	61.9	67.5	GAS2709NOS	RST200NOSA
50	66.7	71.4	GAS2885NOS	RST200NOSA
75	86.9	93.3	GAS3760NOS	RST300NOSA
75	93.7	96.4	GAS3885NOS	RST300NOSA



## EZ Boss-Lock™ Swaged Type C

Developed specifically for chemical transport hoses having Crosslinked Polyethylene (XLPE) or Ultra High Molecular Weight Polyethylene (UHMW) tubes. Swaged Boss-Lock™ provides you with a permanently attached cam & groove fitting when superior coupling retention is required.

When tank transport hoses from a wide variety of manufacturers were tested, the Swaged Boss-Lock™ fitting proved itself to be the clear winner in overall performance. Fittings are also available on special order for other sizes or hose ODs. Consult Dixon™ for pricing and availability.

Coupler x Hose Shank with Ferrule			
Size (mm)	Minimum Hose OD (mm)	Maximum Hose OD (mm)	Stainless Steel Part No.
20	27.78	39.69	RC075EZ-70
25	34.13	42.86	RC100EZ-70



## EZ Boss-Lock™ Swaged Type E

Adaptor x Hose Shank with Ferrule			
Size (mm)	Minimum Hose OD (mm)	Maximum Hose OD (mm)	Stainless Steel Part No.
20	27.78	34.13	RE075-1370
25	36.91	39.29	RE100-1620
25	39.69	42.86	RE100-1770



For technical, application, and material guidelines, please refer to page 8



## EZLink™ Armless Cam & Groove



<b>Application:</b>	<ul style="list-style-type: none"> <li>Transfer and/or unloading of fuels (petroleum or diesel) from tank truck to storage tanks</li> <li>Transfer of liquids compatible with the available coupling and gasket materials</li> </ul>
<b>Features:</b>	<ul style="list-style-type: none"> <li>Automatic couplers push-to-connect providing a reliable connection</li> <li>Low profile allows easy connection and disconnection in tight applications</li> <li>Coupler push tabs can be locked with safety pins and/or zip tie</li> <li>Compatible with standard cam &amp; groove adaptors</li> <li>Lifetime warranty on stainless-steel tabs</li> </ul>
<b>Materials:</b>	<ul style="list-style-type: none"> <li>Couplings and dust caps: A356 aluminium, 316 stainless steel</li> <li>Coupler tabs and springs: 316 stainless steel</li> <li>Gasket: Buna-N</li> </ul>
<b>Specifications:</b>	<ul style="list-style-type: none"> <li>Maximum working pressure with King Crimp™ ferrules: 2" <b>250 PSI</b>, 3" and 4" <b>150 PSI</b></li> <li>Maximum working pressure with crimp sleeves: 2" <b>250 PSI</b>, 3" <b>125 PSI</b>, 4" <b>110 PSI</b></li> <li>Maximum working pressure with band clamps: 2" <b>250 PSI</b>, 3" <b>125 PSI</b>, 4" <b>100 PSI</b></li> <li>Gasket temperature range: <b>-15°C to 82°C</b></li> </ul>



Coupler x Male NPT (Type B)		
Size (inch)	A356 Aluminium	316 Stainless Steel
	Part No.	Part No.
1½	EZL150-B-AL	EZL150-B-SS
2	EZL200-B-AL	EZL200-B-SS
3	EZL300-B-AL	EZL300-B-SS
4	EZL400-B-AL	---

BSP available upon request.



Coupler x King Crimp™ Hose Shank (Type C)		
Size (inch)	A356 Aluminium	316 Stainless Steel
	Part No.	Part No.
1½	EZL150-C-AL	EZL150-C-SS
2	EZL200-C-AL	EZL200-C-SS
3	EZL300-C-AL	EZL300-C-SS
4	EZL400-C-AL	---



Coupler x Female NPT (Type D)		
Size (inch)	A356 Aluminium	316 Stainless Steel
	Part No.	Part No.
1½	EZL150-D-AL	EZL150-D-SS
2	EZL200-D-AL	EZL200-D-SS
3	EZL300-D-AL	EZL300-D-SS
4	EZL400-D-AL	---

BSP available upon request.



Dust Caps (Type DC)		
Size (inch)	A356 Aluminium	316 Stainless Steel
	Part No.	Part No.
1½	EZL150-DC-AL	EZL150-DC-SS
2	EZL200-DC-AL	EZL200-DC-SS
3	EZL300-DC-AL	EZL300-DC-SS
4	EZL400-DC-AL	---

 Only use EZLink™ gaskets and tabs for this coupling system. Traditional cam & groove handles and gaskets, or other types of seals are not compatible and will fail.

## EZLink™ Armless Cam & Groove Replacement Parts and Kits

A

Replacement Kits		
Size (inch)	Kit Contains	Part No.
2	2 pins, 2 springs, and 2 tabs	EZL200RPLKIT
3 and 4	2 pins, 2 springs, and 2 tabs	EZL300RPLKIT



Replacement Gaskets			
Size (inch)	Buna-N	Fluorosilicone	FKM
	Part No.	Part No.	Part No.
1½	EZL150-G-BU	EZL150-G-FV	EZL150-G-VI
2	EZL200-G-BU	EZL200-G-FV	EZL200-G-VI
3	EZL300-G-BU	EZL300-G-FV	EZL300-G-VI
4	EZL400-G-BU	EZL400-G-FV	EZL400-G-VI



<b>Feature:</b>	• Clip is optional.
-----------------	---------------------

<b>Safety Clip</b>	
Plated Carbon Steel Part No.	
EZLCL400	



# Cam & Groove

## Adaptor x 150# Flange

A



Size (inch)	356T6 Aluminium	316 Stainless Steel
	Part No.	Part No.
1	---	100-AL-SS
1½	---	150-AL-SS
2	200-AL-AL	200-AL-SS
3	300-AL-AL	300-AL-SS
4	400-AL-AL	400-AL-SS
6	600-AL-AL	600-AL-SS
8	800-AL-AL <sup>1</sup>	---

## Adaptor x 150# ANSI Flange



Size (inch)	316 Stainless Steel
	Part No.
2	200-AL-SSANSI
3	300-AL-SSANSI

## Dixon™ Coupler x 150# Flange



Size (inch)	356T6 Aluminium	316 Stainless Steel
	Part No.	Part No.
1	---	100-DL-SS
1½	---	150-DL-SS
2	200-DL-AL	200-DL-SS
3	300-DL-AL	300-DL-SS
4	400-DL-AL	400-DL-SS
6	600-DL-AL	600-DL-SS
8	800-DL-AL <sup>1</sup>	---

- Buna-N gasket standard, other gaskets available on pages 33 - 35

## EZ Boss-Lock™ Coupler x 150# Flange



Size (inch)	316 Stainless Steel
	Part No.
1	RDL100EZ <sup>1</sup>
1½	RDL150EZ <sup>1</sup>
2	RDL200EZ
3	RDL300EZ <sup>1</sup>
4	RDL400EZ <sup>1</sup>
6	RDL600EZ <sup>1</sup>

- Buna-N gasket standard, other gaskets available on pages 33 - 35

<sup>1</sup> Contact Dixon™ for specifications and alternative flange options.

## Reducing Adaptors & Couplers

A

Reducing Adaptor x Female Type A

Size (mm) Adaptor & BSP	Max WP (PSI)	Aluminium	Stainless Steel
		Part No.	Part No.
50 x 40	250	2015-A-ALA	2015-A-SSA
50 x 75	125	2030-A-ALA	2030-A-SSA
75 x 50	125	3020-A-ALA	3020-A-SSA
75 x 100	100	3040-A-ALA	3040-A-SSA
100 x 75	100	4030-A-ALA	4030-A-SSA
100 x 150	75	4060-A-ALA	4060-A-SSA
150 x 100	75	-	6040-A-SSA



Reducing Coupler x Male Type B

Size (mm) Coupler & BSP	Max WP (PSI)	Aluminium	Stainless Steel
		Part No.	Part No.
40 x 25	250	1510-B-ALA	1510-B-SSA
50 x 40	250	2015-B-ALA	2015-B-SSA
50 x 75	250	2030-B-ALA	2030-B-SSA
75 x 50	125	3020-B-ALA	3020-B-SSA
75 x 100	125	3040-B-ALA	3040-B-SSA
100 x 75	100	4030-B-ALA	4030-B-SSA



Reducing Coupler x Hose Tail Type C

Size (mm) Coupler & Tail	Max WP (PSI)	Aluminium	Stainless Steel
		Part No.	Part No.
50 x 40	250	2015-C-AL	2015-C-SS
75 x 50	125	3020-C-AL	3020-C-SS
75 x 100	125	3040-C-AL	3040-C-SS
100 x 75	100	4030-C-AL	4030-C-SS
125 x 100	75	5040-C-AL	-



Reducing Coupler x Female Type D

Size (mm) Coupler & BSP	Max WP (PSI)	Aluminium	Stainless Steel
		Part No.	Part No.
40 x 25	250	1510-D-AL	1510-D-SS
50 x 40	250	2015-D-AL	2015-D-SS
75 x 50	125	3020-D-AL	3020-D-SS
100 x 75	100	4030-D-AL	4030-D-SS



NOTE: If a coupling is a reducing size, the coupler or adaptor is the first size (ie, a 4030-C-AL is a 100mm coupler to a 75mm hose tail).

- BSP threads available

# Cam & Groove

A

## Reducing Adaptors & Couplers



Reducing Adaptor x Hose Tail Type E			
Size (mm) Adaptor & Tail	Max WP (PSI)	Aluminium	Stainless Steel
		Part No.	Part No.
50 x 40	250	2015-E-AL	2015-E-SS
75 x 50	125	3020-E-AL	3020-E-SS
100 x 75	100	4030-E-AL	4030-E-SS
125 x 100	75	5040-E-AL	-



Reducing Adaptor x Male Type F			
Size (mm) Adaptor & BSP	Max WP (PSI)	Aluminium	Stainless Steel
		Part No.	Part No.
40 x 50	250	1520-F-AL	-
50 x 40	250	2015-F-AL	2015-F-SS
50 x 75	250	2030-F-AL	-
75 x 40	125	3015-F-AL	3015-F-SS
75 x 50	125	3020-F-AL	3020-F-SS
75 x 100	125	3040-F-AL	-
100 x 75	100	4030-F-AL	4030-F-SS

NOTE: If a coupling is a reducing size, the coupler or adaptor is the first size (ie, a 4030-C-AL is a 100mm coupler to a 75mm hose tail).

- BSP threads are available

## Dixon™ Reducing Adaptors & Couplers

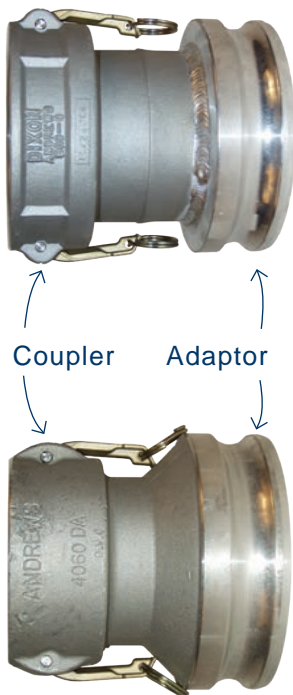

Coupler & Adaptor			
Size (mm) Adaptor & BSP	Max WP (PSI)	Aluminium	Stainless Steel
		Part No.	Part No.
40 x 25	250	1510-DA-AL	1510-DA-SS
40 x 50	250	1520-DA-AL	1520-DA-SS
50 x 40	250	2015-DA-AL	2015-DA-SS
50 x 75	125	2030-DA-AL	2030-DA-SS
50 x 100	100	2040-DA-AL	2040-DA-SS
75 x 40	125	3015-DA-AL	3015-DA-SS
75 x 50	125	3020-DA-AL	3020-DA-SS
75 x 100	100	3040-DA-AL	3040-DA-SS
100 x 50	100	4020-DA-AL	4020-DA-SS
100 x 75	100	4030-DA-AL	4030-DA-SS
100 x 150	100	4060-DA-AL	4060-DA-SS
150 x 75	75	6030-DA-AL	6030-DA-SS
150 x 100	75	6040-DA-AL	6040-DA-SS
150 x 125	75	6050-DA-AL	6050-DA-SS

## Spool Adaptors

Size (mm) Adaptor x Adaptor	Max WP (PSI)	Aluminium	Stainless Steel
		Part No.	Part No.
25	250	100-AA-AL	100-AA-SS
32	250	125-AA-AL	125-AA-SS
40	250	150-AA-AL	150-AA-SS
40 x 50	250	1520-AA-AL	1520-AA-SS
50	250	200-AA-AL	200-AA-SS
50 x 75	125	2030-AA-AL	2030-AA-SS
65	150	250-AA-AL	---
65 x 75	125	2530-AA-AL	2530-AA-SS
65 x 100	100	2540-AA-AL	---
75	125	300-AA-AL	300-AA-SS
75 x 100	100	3040-AA-AL	3040-AA-SS
100	100	400-AA-AL	400-AA-SS
100 x 125	75	4050-AA-AL	---
100 x 150	75	4060-AA-AL	4060-AA-SS
150	75	600-AA-AL	600-AA-SS



Same size  
both ends

Adaptor



Reducer

## Dixon™ Aluminium Coupler x Adaptor Y

Size (inch)	356T6 Aluminium
	Part No.
2	200YDAAAL



## Spool Couplers

Size (mm)	Max WP (PSI)	Aluminium	Stainless Steel
		Part No.	Part No.
50	250	200-DD-AL	200-DD-SS
50 x 75	125	2030-DD-AL	2030-DD-SS
75	125	300-DD-AL	300-DD-SS
75 x 100	100	3040-DD-AL	-
100	100	400-DD-AL	400-DD-SS

Coupler



Coupler

## Dixon™ Lockable Dust Caps

Size (inch)	316 Stainless Steel
	Part No.
1½	150DC-LSS
2	200DC-LSS
3	300DC-LSS
4	400DC-LSS



 • Dust Caps and Dust Plugs are **NOT** to be used in pressure applications for safety and environmental reasons

**For technical, application, and material guidelines, please refer to page 8**

A

## Dixon™ Type DA 45° Elbows



adaptor x coupler

Size (inch)	356T6 Aluminium	316 Stainless Steel
	Part No.	Part No.
2	200DA-45AL <sup>1</sup>	200DA-45SS <sup>1</sup>
3	300DA-45AL	300DA-45SS <sup>1</sup>
4	400DA-45AL	400DA-45SS <sup>1</sup>
6	600DA-45AL	---

## Dixon™ Type DA 90° Elbows



adaptor x coupler

Size (inch)	356T6 Aluminium	316 Stainless Steel
	Part No.	Part No.
1	---	100DA-90SS <sup>1</sup>
1½	150DA-90AL <sup>1</sup>	150DA-90SS <sup>1</sup>
2	200DA-90AL	200DA-90SS
3	300DA-90AL	300DA-90SS
4	400DA-90AL	400DA-90SS

## Dixon™ Type DA Coupler x Adaptor



4030-DA-SS



4060-DA-AL



2015-DA-AL



5060-DA-AL

Size (inch)	356T6 Aluminium	316 Stainless Steel
	Part No.	Part No.
1 x 1½	1015-DA-AL <sup>1</sup>	1015-DA-SS <sup>1</sup>
1½ x 1	1510DAAL	1510-DA-SS <sup>1</sup>
1½ x 2	1520-DA-AL	1520-DA-SS
2 x 1	2010-DA-AL <sup>1</sup>	2010-DA-SS
2 x 1½	2015-DA-AL	2015-DA-SS
2 x 2½	2025-DA-AL <sup>1</sup>	2025-DA-SS <sup>1</sup>
2 x 3	2030-DA-AL	2030-DA-SS
2 x 4	2040-DA-AL	2040-DA-SS <sup>1</sup>
2½ x 2	---	2520-DA-SS <sup>1</sup>
2½ x 3	---	2530-DA-SS <sup>1</sup>
3 x 1½	3015-DA-AL	3015-DA-SS <sup>1</sup>
3 x 2	3020-DA-AL	3020-DA-SS
3 x 2½	3025-DA-AL <sup>1</sup>	3025-DA-SS <sup>1</sup>
3 x 4	3040-DA-AL	3040-DA-SS
3 x 6	3060-DA-AL <sup>1</sup>	3060-DA-SS <sup>1</sup>
4 x 2	4020-DA-AL	4020-DA-SS <sup>1</sup>
4 x 2½	4025-DA-AL	4025-DA-SS <sup>1</sup>
4 x 3	4030-DA-AL	4030-DA-SS
4 x 5	4050-DA-AL	---
4 x 6	4060-DA-AL	4060-DA-SS <sup>1</sup>
5 x 3	5030-DA-AL <sup>1</sup>	5030-DA-SS <sup>1</sup>
5 x 4	5040-DA-AL	5040-DA-SS <sup>1</sup>
5 x 6	5060-DA-AL <sup>1</sup>	5060-DA-SS <sup>1</sup>
6 x 3	6030-DA-AL	6030-DA-SS <sup>1</sup>
6 x 4	6040-DA-AL	6040-DA-SS
6 x 5	6050-DA-AL	6050-DA-SS <sup>1</sup>
8 x 6	8060-DA-AL <sup>1,2</sup>	---

<sup>1</sup> Parts are produced as a welded fabrication

<sup>2</sup> The 8" coupler only interchanges with Dixon™ adaptors.

Size (inch)	Brass	Unplated Malleable Iron
	Part No.	Part No.
3 x 2	3020-DA-BR	3020-DA-MI
3 x 4	3040-DA-BR	---
4 x 3	4030-DA-BR	4030-DA-MI
6 x 4	6040-DA-BR	6040-DA-MI

Note: In reducing cam & groove couplings, the coupler is the first size in the part number; (i.e., a 4030-DA-AL is a 4" coupler to a 3" adaptor).

<sup>1</sup> Part is produced as a welded fabrication

For technical, application, and material guidelines, please refer to page 8





A

## Dixon™ Type DD 45° Elbows

Size (inch)	356T6 Aluminium	316 Stainless Steel
	Part No.	Part No.
2	200DD-45AL <sup>1</sup>	---
3	300DD-45AL <sup>1</sup>	300DD-45SS <sup>1</sup>
4	400DD-45AL	---



coupler x coupler

## Dixon™ Type DD 90° Elbows

Size (inch)	356T6 Aluminium	316 Stainless Steel
	Part No.	Part No.
2	200DD-90AL	---
3	300DD-90AL <sup>1</sup>	300DD-90SS <sup>1</sup>
4	400DD-90AL	---



coupler x coupler

## Type A 90° Adaptor Elbows

Size (inch)	356T6 Aluminium	316 Stainless Steel
	Part No.	Part No.
1½	150A-90AL	---
2	200A-90AL	200A-90SS <sup>1</sup>
3	300A-90AL	300A-90SS
4	400A-90AL	---



adaptor x female NPT

## Type B 90° Dixon™ Elbows

Size (inch)	356T6 Aluminium	316 Stainless Steel
	Part No.	Part No.
1½	150B-90AL	---
2	200B-90AL	200B-90SS <sup>1</sup>
3	---	300B-90SS <sup>1</sup>



coupler x male NPT

<sup>1</sup> Parts are produced as a welded fabrication

A

**Type C 90° Dixon™ Elbows**

coupler x hose shank

Size (inch)	356T6 Aluminium	316 Stainless Steel	Brass
	Part No.	Part No.	Part No.
1¼	---	---	125C-90BR
1½	150C-90AL	150C-90SS	---
2	200C-90AL	200C-90SS	200C-90BR
3	300C-90AL	300C-90SS	---
4	400C-90AL	400C-90SS <sup>1</sup>	---
6	600C-90AL	---	---

**Type D 90° Dixon™ Elbows**

coupler x female NPT

Size (inch)	356T6 Aluminium	316 Stainless Steel	Brass
	Part No.	Part No.	Part No.
1	---	100D-90SS	---
1¼	---	---	125D-90BR
1½	150D-90AL	---	150D-90BR
2	200D-90AL	200D-90SS	200D-90BR
3	300D-90AL	300D-90SS	---
4	400D-90AL	400D-90SS <sup>1</sup>	---
4	AD90400EZ <sup>2</sup>	---	---
6	600D-90AL	---	---

<sup>2</sup> EZ Boss-Lock™ design

EZ Boss-Lock™ design

**Type E 90° Elbows**

adaptor x hose shank

Size (inch)	356T6 Aluminium	316 Stainless Steel
	Part No.	Part No.
2	---	200E-90SS <sup>1</sup>
3	300E-90AL	300E-90SS
4	400E-90AL	400E-90SS <sup>1</sup>

**Type F 90° Elbows**

adaptor x male NPT

Size (inch)	356T6 Aluminium	316 Stainless Steel
	Part No.	Part No.
1½	150F-90AL	---
2	200F90AL	200F-90SS <sup>1</sup>
3	---	300F-90SS <sup>1</sup>

<sup>1</sup> Parts are produced as a welded fabrication

## Gaskets

Size (mm)	Buna - N	FKM-A	Extra Thick Buna-N	Ethylene Propylene
	Black + 1 Blue Stripe	Black + 1 Yellow Stripe	Black + 2 Blue Stripes	Black + 1 White Stripe
	Part No.	Part No.	Part No.	Part No.
15	50-G-BU	50-G-VI	---	---
20	75-G-BU	75-G-VI	---	75-G-EPR
25	100-G-BU	100-G-VI	100GTHK	100-G-EPR
32	125-G-BU	125-G-VI	125GTHK	---
40	150-G-BU	150-G-VI	150GTHK	150-G-EPR
50	200-G-BU	200-G-VI	200GTHK	200-G-EPR
65	250-G-BU	250-G-VI	250GTHK	250-G-EPR
75	300-G-BU	300-G-VI	300GTHK	300-G-EPR
100	400-G-BU	400-G-VI	400GTHK	400-G-EPR
125	500-G-BU	500-G-VI	---	---
150	600-G-BU	600-G-VI	600GTHK	---
200	800-G-BU	800-G-VI	---	---



A

Size (mm)	Neoprene	White Neoprene	White Buna N	Silicone
	Black + 1 Red Stripe	White + None	White + 1 Blue Stripe	Red + None
	Part No.	Part No.	Part No.	Part No.
20	75-G-NE	---	---	---
25	100-G-NE	---	---	---
40	150-G-NE	150-G-WNE	---	---
50	200-G-NE	200-G-WNE	---	200-G-SIL
65	250-G-NE	---	---	---
75	300-G-NE	300-G-WNE	300-G-WB	300-G-SIL
100	400-G-NE	400-G-WNE	400-G-WB	400-G-SIL
125	---	500-G-WNE	---	---
150	---	600-G-WNE	---	---



- Since other manufacturers' coding systems vary, this chart should not be used as a reference in identifying gaskets of unknown origin
- PTFE white Buna filler (TFWB) and PTFE encapsulated silicone (TES)
- PTFE accordion gaskets (TFACC) are recommended for use with viscous (thick) fluids only, maximum operating temperature **200°C (392°F)**
- Encapsulated gasket pressure ratings are reduced to **125PSI** for ½" to 2½" at ambient temperature **21°C (70°F)** when these gaskets are used
- PTFE encapsulated FKM (TEV) gaskets - maximum operating temperature **93°C (199°F)**
- PTFE encapsulated silicone gaskets (TES) gaskets - maximum operating temperature **107°C (224°F)**
- Maximum operating temperatures for specific chemicals may be lower. Contact Dixon™ for specific recommendations
- PTFE encapsulated FKM (TFVI) envelope gaskets - maximum operating temperature **180°C (356°F)**
- PTFE white Buna filler (TFWB) envelope gaskets - maximum operating temperature **80°C (176°F)**
- PTFE ethylene propylene filler (TFEP) envelope gaskets - maximum operating temperature **170°C (338°F)**

# Cam & Groove

## PTFE Gaskets

A

The torque (force) required to close the handles on a pair of cam & groove fittings will vary according to the gasket chosen. Due to the nature of the PTFE material, the various PTFE gasket designs will require the most torque, increasing as you go from envelope to encapsulated and finally, accordion.

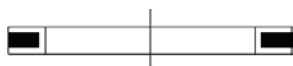

Size (mm)	Envelope Gaskets			
	PTFE Buna Filler	PTFE FKM Filler	PTFE White Buna Filler	PTFE Ethylene Propylene Filler
	White/Black + 1 Blue Stripe	White/Black + 1 Yellow Stripe	White/White + 1 Blue Stripe	White/Black + 1 White Stripe
	Part No.	Part No.	Part No.	Part No.
15	50-G-TF	50-G-TF-VI	---	---
20	75-G-TF	75-G-TF-VI	---	---
25	100-G-TF	100-G-TF-VI	---	---
32	125-G-TF	125-G-TF-VI	---	---
40	150-G-TF	150-G-TF-VI	---	150GTFEP
50	200-G-TF	200-G-TF-VI	200GTFWB	200GTFEP
65	250-G-TF	250-G-TF-VI	---	---
75	300-G-TF	300-G-TF-VI	300GTFWB	300GTFEP
100	---	400-G-TF-VI	400GTFWB	---
125	---	---	500GTFWB	---
150	600-G-TF	---	---	---



Size (mm)	Encapsulated Gaskets		Accordion Gaskets
	PTFE Encapsulated Silicone	PTFE Encapsulated FKM	PTFE Accordion
	Translucent/Red + None	Translucent/Black + None	White + None
	Part No.	Part No.	Part No.
20	75-G-TES	75-G-TEV	75GTFACC
25	100-G-TES	100-G-TEV	100GTFACC
32	125-G-TES	125-G-TEV	125GTFACC
40	150-G-TES	150-G-TEV	150GTFACC
50	200-G-TES	200-G-TEV	200GTFACC
65	250-G-TES	---	---
75	300-G-TES	300-G-TEV	300GTFACC
100	400-G-TES	400-G-TEV	---



## Fuel Gaskets



Size (inch)	Material	Part No.
1½	Buna	150-G-BF
2	Buna	200-G-BF
3	Buna	300-G-BF
4	Buna	400-G-BF
3	extra thick Buna-N	300GTHKBF
4	extra thick Buna-N	400GTHKBF

## Gaskets Colour Codes

A

Gasket Code <sup>1</sup>	Material	Colour	Colour code stripes (appear on the OD of the gasket or filler)
-BU	Buna-N (standard in all metal fittings)	black	1 blue
-BF	Buna (formulated for fuel service)	black	1 green
-VI	FKM	black	1 yellow
-THK	Extra Thick Buna	black	2 blue
-EPR	Ethylene Propylene	black	1 white
-NE	Neoprene	black	1 red
-WNE	White Neoprene	white	none
-WB	White Buna-N	white	blue
-SIL	Silicone	red	none
-TF	PTFE (TFE) envelope with Buna-N filler	white / black	1 blue
TFVI	PTFE (TFE) envelope with FKM filler	white / black	1 yellow
TFWB	PTFE (TFE) envelope with White Buna-N filler	white / white	blue
TFEP	PTFE (TFE) envelope with Ethylene Propylene filler	white / black	1 white stripe
-TES	PTFE (FEP) encapsulated Silicone core	translucent / red	none
-TEV	PTFE (FEP) encapsulated FKM core	translucent / black	none
TFACC	PTFE (TFE) accordion	white	none

<sup>1</sup> Part number suffix



Since other manufacturers' coding systems vary, this chart should not be used as a reference in identifying gaskets of unknown origin.

The following are the nominal dimensions for Dixon™'s elastomeric cam & groove gaskets.

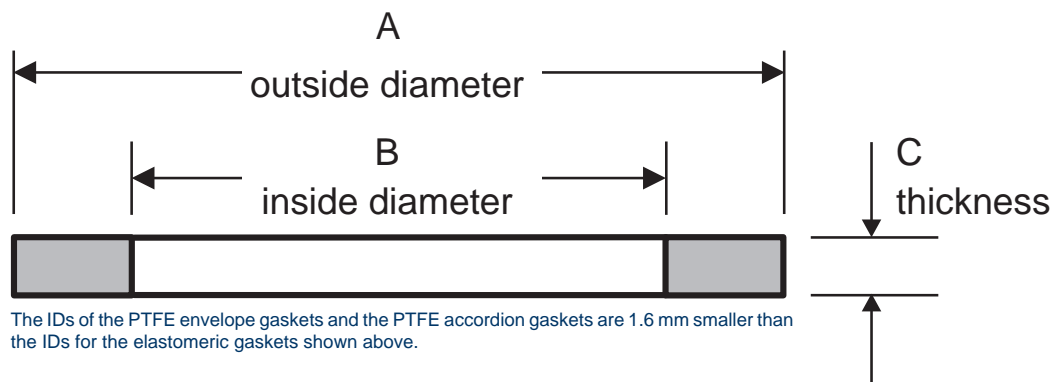

The IDs of the PTFE envelope gaskets and the PTFE accordion gaskets are 1.6 mm smaller than the IDs for the elastomeric gaskets shown above.

Size (mm)	Type	A OD	B ID	C Thickness*
15	50-G	26.19	17.46	3.96
20	75-G	34.93	22.23	5.54
25	100-G	39.69	26.98	6.35
32	125-G	49.21	34.53	6.35
40	150-G	55.56	41.28	6.35
50	200-G	66.68	50.80	6.35
65	250-G	79.38	60.33	6.35
75	300-G	94.46	76.20	6.35
100	400-G	123.83	101.60	6.35
125	500-G	150.81	123.83	6.35
150	600-G	179.39	152.40	6.35
200	800-G	236.54	206.38	8.71

\* Thicknesses of PTFE accordion gaskets may vary from chart above.



No interchange standard exists for the ½" (15mm) and 8" (200mm) fittings. Generally, these sizes do not interchange with other manufacturers' products. As such, the gaskets in these sizes are not suitable for use in other manufacturers' couplings.

For technical, application, and material guidelines, please refer to page 8



+44 (0)1772 323529  
europe.dixonvalve.com

sale@technobearing.ru

TECHNOBEARING.RU

DGEL2020

8 (800) 700-72-07

# Cam & Groove

A

## Handles for Aluminium / Brass Global Couplers



supplied complete with ring and pin

Fits on sizes		Investment Stainless Part No.
inch	mm	
½ and ¾	13 and 20	G75HRP
1	25	G100HRP
1½ and 2	38 and 50	G152HRPSI
3 - 5	75 - 125	G34HRPSI
6	150	G600HRPSI



supplied complete with ring and pin

Fits on sizes		Forged Brass Part No.
inch	mm	
1¼ - 2½	32 - 63	G152HRP
3 - 5	75 - 125	G34HRP
6 and 8	150 and 200	G600HRP



- Global Dixon™ handle assemblies are only to be used with global Dixon™ parts (not domestic). Handles do not interchange with other manufacturers' handles or couplers.

## Handles for Stainless Global Couplers



supplied complete with ring and pin

Fits on sizes		Investment Stainless Part No.
inch	mm	
½ and ¾	13 and 20	G75HRPSS
1	25	G100HRPSS
1¼ - 2½	32 - 63	G125250HRPSS
3 - 5	75 - 125	G300400HRPSS
6	150	G600HRPSS



- Global Dixon™ handle assemblies are only to be used with global Dixon™ parts (not domestic). Handles do not interchange with other manufacturers' handles or couplers.

## Safety Clip for Global Couplers



Zinc Plated Carbon Steel Part No.	Bag Qty
GSAFETYCLIP	25

## Locking Handles for Dixon™ Dust Caps



Not supplied with pins

Description	Size		Part No.
	inch	mm	
Locking Handle, Brass	2	50	200-LH-BR
Locking Handle, Brass	3	75	300-LH-BR
Locking Handle, Brass	4	100	400-LH-BR
Locking Handle, Brass	6	150	600-LH-BR

## EZ Boss-Lock™ Handles



Materials:		<ul style="list-style-type: none"> <li>Investment cast stainless steel cam arm and lever</li> <li>316 stainless steel spring</li> <li>Stainless steel pin and washer; plated carbon steel pull ring</li> </ul>	
Size		Part No.	
inch	mm		
¾ - 1	20 - 25	RHEZ175	
1¼ - 2½	32 - 63	RHEZ152	
3 and 4	75 and 100	RHEZ34	



UNDER NO CIRCUMSTANCES should the EZ Boss-Lock™ cam arms be used on any fitting not specifically produced for their use. The aluminium, brass, and malleable iron are made from sand castings. To ensure proper functioning of the EZ Boss-Lock™ cam arm assemblies, we sort the castings to ensure there is sufficient length and orientation on the lugs on the main casting to engage the lever. We also buff or grind the rougher sand cast surface to ensure that the lever will move freely. The EZ Boss-Lock™ cam arms cannot be retrofitted onto existing aluminium, brass, or plated malleable iron Boss-Lock™ already in service.

**For technical, application, and material guidelines, please refer to page 8**

## Witches Hat Strainers

Size (inch)	Part No.
3	WH300-A
4	WH400-A



A

## Gaskets for Witches Hat Strainers

<b>Material:</b>	• Buna-N
Size (inch)	Part No.
3	WH300-G
4	WH400-G



## Disk Strainers

<b>Features:</b>		<ul style="list-style-type: none"> <li>• Threads into bottom of female NPT fitting to protect equipment from large contaminants</li> <li>• 304 stainless steel parts are investment castings</li> </ul>	
Size (inch)	Hole Size (inch)	6061T6 Aluminium	304 Stainless Steel
		Part No.	Part No.
2	¼	SDA200	SDS200
3	¼	SDA300	SDS300
4	¼	SDA400	SDS400



## Lanyards with Clip for Boss-Lock™ Couplings

<b>Materials:</b>	<ul style="list-style-type: none"> <li>• Clip: carbon steel</li> <li>• Lanyard: nylon</li> </ul>
Size (mm)	Part No.
20 and 25	ACL4
32 - 100	ACL2
150	ACL3

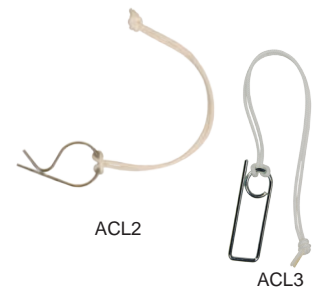

## PVC Coated Lanyards

Part No.	Description
CAL15	375mm long PVC coated carbon steel with aluminium crimp sleeves. One end Dixon™ crimped, one end uncrimped for field installation.

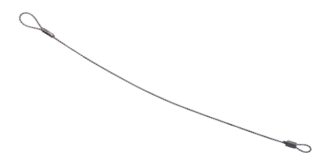

## Pull Ring Safety Clips for Boss-Lock™ Couplings

Coupler Size (inch)	Carbon Steel	316 Stainless Steel
	Part No.	Part No.
1¼ - 2½	200PRSCCS	200PRSCSS
3 and 4	300PRSCCS	300PRSCSS



**For technical, application, and material guidelines, please refer to page 8**

A

**Clip for Boss-Lock™ Coupling**

Part No.	Description
AC7	.072 stainless steel wire

**Carbon Steel Clip Assembly**

For Boss-Lock™ couplings

Part No.	Description
BLCA152CS	pull ring, chain and ACL3 clip

**Stainless Steel Pull Rings**

Part No.	Description
R200SS	pull ring, 304 stainless steel, approximate diameter: 35mm

**Jack Chain with S-Hooks**

Part No.	Description
CH-B-6	150mm brass
CH-B-12	300mm brass
CH-C-12	300mm carbon steel
CH-SS-6	150mm stainless steel
CH-SS-12	300mm stainless steel
CH-SS-24	600mm stainless steel

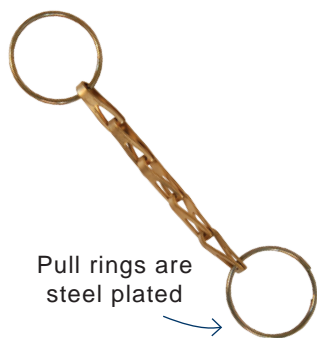
**Sash Chain with Pull Rings**

Pull rings are steel plated

Part No.	Description
J125	115mm brass
J150	165mm brass
J300	215mm brass
J500	325mm brass

**Bottle Opener**

Part No.
CAMOPENER

For technical, application, and material guidelines, please refer to page 8



## Locking Cam Arm Velcro® Straps

<b>Applications:</b>	<ul style="list-style-type: none"> <li>Use with cam &amp; groove couplers to prevent spills, secure from damage, and hold in place during transport</li> </ul>
<b>Features:</b>	<ul style="list-style-type: none"> <li>Used on the female end of the cam &amp; groove coupler</li> <li>High visibility orange hook and loop with metal buckle provide strength, durability, and long life</li> </ul>
<b>Specifications:</b>	<ul style="list-style-type: none"> <li>Temperature range: <b>-57°C to 93°C (-70°F to 200°F)</b></li> </ul>

Length (inch)	Used On	Part No.
18	fits up to 3" coupler	CVS18
36	fits up to 8" coupler	CVS36



coupler sold separately

## Abrasion Resistant Inserts

<b>Features:</b>	<ul style="list-style-type: none"> <li>Extends the life of adaptors when transferring proppant to storage tanks</li> <li>Available for multiple adaptor and multiple coupler materials</li> </ul>
<b>Materials:</b>	<ul style="list-style-type: none"> <li>UHMW polyethylene</li> </ul>

Part No.	Description
400-A-INSERT	to be used with 400-A-AL, 400-A-BR, 400-A-MI, 400-A-SS
400-C-INSERTAL	to be used with 400-C-AL
400-C-INSERTMI	to be used with 400-C-MI



400-A-INSERT



400-C-INSERTAL

**For technical, application, and material guidelines, please refer to page 8**

# Industrial Hose Fittings Index

B

Air King™	41-45
European Compressor	46-47
Smooth Tails	48-49
Storz Fittings	50-52
King™ Safety	53-56
Brass Fittings	57-71
Boss LPS	72-78
Swivel Joints	79-85
Spray Guns	86
ADS Outalarms	87
Combination Nipples	88-95
Strainers	96-97
Agri-Lock Bauer Couplings	98-100
Boss Fittings	101-110
Steam Hose Fittings - BS EN	111
King Crimp™	112-121
Holedall™	122-135



## Air King™ Hose Ends

 • Air King™ is for air and water services only

Iron				
Size (inch)	Part No.	Working Pressure		Pkg Qty
		PSI	MPa	
3/8	GAMH	150	1	25
1/2	GAM1	150	1	50
5/8	GAM5	150	1	50
3/4	GAM6	150	1	50
1	GAM11	150	1	50

Brass				
Size (inch)	Part No.	Working Pressure		Pkg Qty
		PSI	MPa	
3/8	ABH	150	1	25
1/2	AB1	150	1	50
5/8	AB5	150	1	50
3/4	AB6	150	1	50
1	AB11	150	1	50

316 Stainless Steel				
Size (inch)	Part No.	Working Pressure		Pkg Qty
		PSI	MPa	
3/8	RAMH	150	1	25
1/2	RAM1	150	1	50
3/4	RAM6	150	1	50
1	RAM11	150	1	50

All universal couplings listed above include safety clip.

## Air King™ 4-Lug Quick-Acting Couplings

 • Air King™ is for air and water services only

Plated Steel Hose Ends				
Size (inch)	Part No.	Working Pressure		Pkg Qty
		PSI	MPa	
1 1/4	GAM16	150	1	25
1 1/2	GAM21	150	1	25
2	GAM26	150	1	10

Plated Steel Female NPT Ends				
Size (inch)	Part No.	Working Pressure		Pkg Qty
		PSI	MPa	
1 1/4	GAM18	150	1	25
1 1/2	GAM23	150	1	25
2	GAM28	150	1	20

For use with Boss™ clamps, refer to pages 109-110.

Note: Must use safety clips. Safety clips are same size for both 2-lug and 4-lug couplings.

 • **WARNING:** Never use couplings for steam service! None of Dixon™'s catalogue information is to be interpreted to mean that this type of coupling is suitable for use on steam hose.

FOR SPECIFICATIONS, APPLICATION, AND MATERIAL GUIDELINES PLEASE REFER TO PAGE 356



B



## Air King™ Male Ends



Size (inch)	Plated Steel BSP	Plated Steel NPT	Working Pressure		Pkg Qty
	Part No.	Part No.	PSI	MPa	
¼	-	GAMB1	150	1	25
¾	-	GAMB	150	1	25
½	GAM2A	GAM2	150	1	50
¾	GAM7A	GAM7	150	1	50
1	GAM12A	GAM12	150	1	50

Size (inch)	Brass NPT	316 Stainless Steel NPT	Working Pressure		Pkg Qty
	Part No.	Part No.	PSI	MPa	
¼	ABB1	-	150	1	25
¾	ABB	RAMB	150	1	25
½	AB2	RAM2	150	1	50
¾	AB7	RAM7	150	1	50
1	AB12	RAM12	150	1	50

## Air King™ Female Ends



Size (inch)	Plated Steel BSP	Plated Steel NPT	Working Pressure		Pkg Qty
	Part No.	Part No.	PSI	MPa	
¼	-	GAMC1	150	1	25
¾	-	AMC	150	1	25
½	GAM3A	GAM3	150	1	50
¾	GAM8A	GAM8	150	1	50
1	GAM13A	GAM13	150	1	50

Size (inch)	Brass NPT	316 Stainless Steel NPT	Working Pressure		Pkg Qty
	Part No.	Part No.	PSI	MPa	
¼	ABC1	-	150	1	25
¾	ABC	RAMC	150	1	25
½	AB3	RAM3	150	1	50
¾	AB8	RAM8	150	1	50
1	AB13	RAM13	150	1	50

All universal couplings listed above include safety clip.



• **WARNING:** Never use couplings for steam service! None of Dixon™'s catalogue information is to be interpreted to mean that this type of coupling is suitable for use on steam hose.

FOR SPECIFICATIONS, APPLICATION, AND MATERIAL GUIDELINES PLEASE REFER TO PAGE 356

## Air King™ Blank Ends

Material	Part No.	Pkg Qty
Iron	GAM0	25
Brass	AB0	25
Stainless Steel	RAM0	-



## 2-Lug Triple Connection

Material	Part No.	Pkg Qty
Iron	GAM10	25
Brass	AB10	25



Note: Universal couplings listed above include safety clip.

**WARNING:** Never use couplings for steam service! None of Dixon™'s catalogue information is to be interpreted to mean that this type of coupling is suitable for use on steam hose.

## Accessories

<b>Features:</b>	<ul style="list-style-type: none"> <li>• 2-lug couplings use the same size washer (AWR4, AWS6)</li> <li>• 4-lug couplings use the same size washer (AWR14)</li> <li>• Neoprene is oil resistant</li> </ul>
<b>Temperature:</b>	<ul style="list-style-type: none"> <li>• Rubber: <b>-29°C to 71°C (-20°F to 159°F)</b></li> <li>• Neoprene: <b>-29°C to 88°C (-20°F to 190°F)</b></li> <li>• FKM: <b>-30°C to 200°C (-22°F to 392°F)</b></li> </ul>

Washers		
Description	Part No.	Pkg Qty
Rubber	AWR4	50
Neoprene	AWS6	50
FKM	AWR4V	50



Safety Clips	
Part No.	Pkg Qty
AC1	25



Air King™ Safety Clips		
Size (mm)	Part No.	Pkg Qty
1.5	AKSP1	25
2	AKSP25	25



Lanyards	
Part No.	Pkg Qty
ACL8	25
LR7	-



ACL8



LR7

Stainless Steel Clips	
Part No.	Pkg Qty
AC7	-



FOR SPECIFICATIONS, APPLICATION, AND MATERIAL GUIDELINES PLEASE REFER TO PAGE 356



## Air King™ with Ferrules

B



### Application:

- Malleable iron and stainless steel Air King™ with carbon steel ferrules can be crimped or swaged-on
- Rated to **150 PSI** working pressure

### Iron

Size (inch)	Hose OD Range (mm)		Part No.
	From:	To:	
½	21.43	26.19	AM1WF
¾	26.99	34.13	AM6WF
1	32.54	38.89	AM11WF-1
1	37.31	43.66	AM11WF

### Stainless Steel

Size (inch)	Hose OD Range (mm)		Part No.
	From:	To:	
½	21.43	26.19	RAM1WF
¾	26.99	34.13	RAM6WF
1	37.31	43.66	RAM11WF



- Iron and stainless steel Air King™ with carbon steel ferrules can be crimped or externally swaged
- Rated to 150PSI working pressure
- For air and water service only

## Air King™ Ferrules



### Features:

- Low profile streamline appearance with maximum retention
- Lightweight
- Can be crimped
- Designed for use with Air King™ fittings
- Reference [dixonvalve.co.uk](http://dixonvalve.co.uk) for crimp recommendations and ferrule OD ranges

### Plated Steel

Size (inch)	Ferrule ID (mm)	Part No.
½	0.906	CCF0906
¾	1.120	CCF1120
	1.149	CCF1149
	1.190	CCF1190
	1.218	CCF1218
	1.246	CCF1246
1	1.438	CCF1438
	1.469	CCF1469
	1.500	CCF1500
	1.531	CCF1531

FOR SPECIFICATIONS, APPLICATION, AND MATERIAL GUIDELINES PLEASE REFER TO PAGE 356

## Air King™ Universal Swivels

Size (inch)	Part No.
½ Male NPT	AM2SWIV
¾ Male NPT	AM7SWIV
¾ Female NPT	AM8SWIV



Male NPT

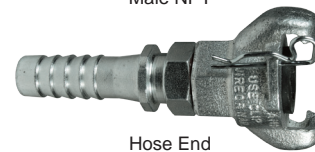

Hose End



Female NPT



 • These universal swivel fittings interchange with other Air King™ fittings and include a heavy-duty, free-turning joint that will swivel under pressure to prevent hose kinking. Working pressure: **150PSI** malleable iron  
• For air and water service only

## Air King™ Double Bolt Clamps

Plated Iron					
Size (inch)	Hose OD Range (mm)		Torque <sup>1</sup> ft/lb	Part No.	Pkg Qty
	From:	To:			
⅜	17.46	22.23	6	CD <sup>3</sup>	100
½	25.4	30.16	6	A4	50
¾	28.58	33.34	12	A9	50
1	33.34	38.10	12	A10 <sup>2,3</sup>	50
1	38.10	46.04	21	A14	50



<sup>1</sup> Recommended torque rating in ft. lbs.

<sup>2</sup> Can be used with GAM6 and GAM11 (refer to page 41)

<sup>3</sup> Investment cast carbon steel

Note: Torque values for clamps are based on "dry bolts". The use of lubricant on bolts will adversely affect clamp performance.

 **WARNING:** Never use Air King™ Clamp for steam service!  
None of Dixon™'s catalogue information is to be interpreted to mean that this type of coupling is suitable for use on steam hose.

## European Compressor Couplings and Clamps

B

<b>Sizes:</b>	<ul style="list-style-type: none"> <li>• 3/8" to 1" (DN10 to DN25)</li> </ul>
<b>Materials:</b>	<ul style="list-style-type: none"> <li>• Ductile iron, malleable iron, investment cast carbon steel, gold chromate plated</li> </ul>
<b>Couplings:</b>	<ul style="list-style-type: none"> <li>• Generally designed to interchange with DIN 3489:2001 couplings</li> </ul>
<b>Clamps:</b>	<ul style="list-style-type: none"> <li>• Generally designed to interchange with DIN 20039:1998 clamp</li> </ul>
<b>Pressure:</b>	<ul style="list-style-type: none"> <li>• Couplings: maximum working pressure <b>150 PSI/10 Bar</b></li> <li>• Claw clamps: maximum working pressure <b>360 PSI/25 Bar</b></li> <li>• Non-claw clamp: maximum working pressure <b>232 PSI/16 Bar</b></li> </ul>
<b>Threads:</b>	<ul style="list-style-type: none"> <li>• BSP Pl. / BSPT in accordance with ISO 228</li> </ul>



Male Adaptor	
Size (inch)	Part No.
3/8	QDM38M
1/2	QDM50M
3/4	QDM75M
1	QDM100M



Female Adaptor	
Size (inch)	Part No.
3/8	QDF38M
1/2	QDF50M
3/4	QDF75M
1	QDF100M



Hose End	
Size (inch)	Part No.
3/8 (no collar)	QDHE38M
1/2 (no collar)	QDHE50M
3/4 (with collar)	QDHE75M
1 (no collar)	QDHE100M



<b>Temperature:</b>	<ul style="list-style-type: none"> <li>• -29°C (-20°F) to 71°C (160°F).</li> </ul>
---------------------	--

Washer for 2-Lug	
Description	Part No.
Black natural rubber	EAWR4
Neoprene	AWS6



## European Compressor Couplings and Clamps

Two-Bolt Saddle Clamps - Malleable Iron			
Size (inch)	Hose OD Range (mm)		Part No.
	From:	To:	
5/8 - 15/16	17	22	TSC25
15/16 - 1-1/8	22	29	TSC31
11/16 - 1-1/4	27	32	TSC34
1-1/4 - 17/16	32	37	TSC37
1-1/2 - 1-15/16	39	49	TSC1305
1-29/32 - 2-3/8	48	60	TSC1306
2-3/8 - 3-1/64	60	76	TSC1307
3-1/32 - 3-11/16	77	94	TSC1308
3-11/16 - 4-1/2	94	115	TSC1309
1-1/8 - 1-1/4	28	32	TSK34 <sup>1</sup>

<sup>1</sup> With investment cast steel safety claws



with Safety Claws



## Smooth Tails BS EN 14420-2:2004 (Hose Side of Stem) BS EN 14420-5:2004 (Threaded Connection)

Smooth Tail Couplings with Collar - Female			
BSPB Thread (inch)	Hose Tail (mm)	Brass Part No.	Stainless Steel Part No.
3/4	19	SF19/BR	SF19/SS
1	25	SF25/BR	SF25/SS
1 1/4	32	SF32/BR	SF32/SS
1 1/2	38	SF38/BR	SF38/SS
2	50	SF50/BR	SF50/SS
2 1/2	65	SF65/BR	SF65/SS
3	75	SF75/BR	SF75/SS
4	100	SF100/BR	SF100/SS



Smooth Tail Couplings with Collar - Male			
BSPB Thread (inch)	Hose Tail (mm)	Brass Part No.	Stainless Steel Part No.
3/4	19	SM19/BR	SM19/SS
1	25	SM25/BR	SM25/SS
1 1/4	32	SM32/BR	SM32/SS
1 1/2	38	SM38/BR	SM38/SS
2	50	SM50/BR	SM50/SS
2 1/2	65	SM65/BR	SM65/SS
3	75	SM75/BR	SM75/SS
4	100	SM100/BR	SM100/SS



Stainless Steel



Brass

# Industrial Hose Fittings

## Fixed & Swivel Flanged Smooth Tails BS EN 14420-2:2004 (Hose Side of Stem) BS EN 14420-2:2004 (Flange Connection)

B



Fixed Flanged Hose Spigots x Tail

Size (DN)	Carbon Steel Part No.	Stainless Steel Part No.
DN25	FF25/CS	FF25/SS
DN32	FF32/CS	FF32/SS
DN40	FF40/CS	FF40/SS
DN50	FF50/CS	FF50/SS
DN65	FF65/CS	FF65/SS
DN80	FF80/CS	FF80/SS
DN100	FF100/CS	FF100/SS



Swivel Flanged Hose Spigots x Tail

Size (DN)	Carbon Steel Part No.	Stainless Steel Part No.
DN25	FS25/CS	FS25/SS
DN32	FS32/CS	FS32/SS
DN40	FS40/CS	FS40/SS
DN50	FS50/CS	FS50/SS
DN65	FS65/CS	FS65/SS
DN80	FS80/CS	FS80/SS
DN100	FS100/CS	FS100/SS
DN125	FS125/CS	---
DN150	FS150/CS	---
DN200	FS200/CS	---

## Tank Wagon Couplings BS EN 14420-6:2004



Tank Wagon Couplings - Female

Size (DN)	Carbon Steel Part No.	Stainless Steel Part No.
DN50	MK50BR	MK50SS
DN80	MK80BR	MK80SS
DN100	MK100BR	MK100SS



Tank Wagon Couplings - Male

Size (DN)	Carbon Steel Part No.	Stainless Steel Part No.
DN50	VK50BR	VK50SS
DN80	VK80BR	VK80SS
DN100	VK100BR	VK100SS

Tank Wagon Couplings - Blanking Plug

Size (DN)	Stainless Steel Part No.
DN50	VB50SS
DN80	VB80SS

Tank Wagon Couplings - Blanking Cap

Size (DN)	Stainless Steel Part No.
DN50	MB50SS
DN80	MB80SS

## Tank Wagon Spares and Seals BS EN 14420-6:2004

Tank Wagon Spares - Locking Ring		
Size (DN)	Carbon Steel Part No.	Stainless Steel Part No.
DN50	MKLR50BR	MKLR50SS
DN80	MKLR80BR	MKLR80SS
DN100	MKLR100BR	MKLR100SS



B

Tank Wagon Spares - Sealing Ring Section		
Size (DN)	Carbon Steel Part No.	Stainless Steel Part No.
DN50	MKSR50BR	MKSR50SS
DN80	MKSR80BR	MKSR80SS
DN100	MKSR100BR	MKSR100SS



Tank Wagon Gaskets - Female Blanking	
Size (DN)	Part No.
DN50	MGB50
DN80	MBG80
DN100	MGB100



Tank Wagon Seals - Hypalon	
Size (DN)	Part No.
DN50	TWHS50
DN80	TWHS80
DN100	TWHS100



Tank Wagon Seals - PTFE Thread	
Size (DN)	Part No.
DN50	TS50T
DN80	TS80T
DN100	TS100T



# Industrial Hose Fittings

## Aluminium Storz Couplings

B

### Storz Adaptors

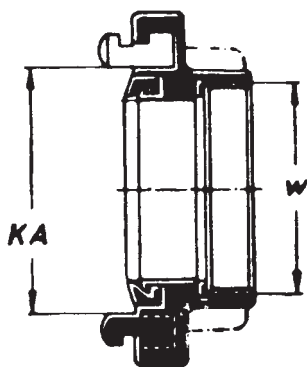

Female (BSPP)

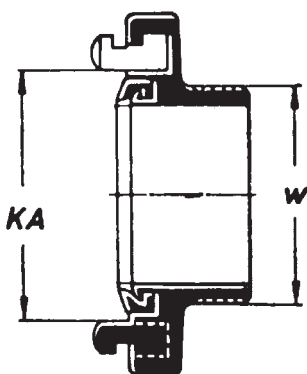

Male (BSPP)

<b>Size Range:</b>	• ½" to 8"
<b>Material:</b>	• Aluminium alloy; Optional stainless steel and brass available
<b>Pressure:</b>	• Maximum working pressure: <b>16 bar/ 232 PSI</b>
<b>Options:</b>	• Both halves of the coupling are of an identical design with no separate male or female halves. Either half can, therefore, be connected to any similar size of coupling. The hose coupling can be connected to another style, e.g.: hose tail, female or male threaded, and blanking caps. It is essential that the distance between locking ears (KA) is the same on all fittings.

#### Female (BSPP)

Nominal Sizes DIN ISO 228	Part No.	Pipe Thread (inch)	KA (mm)
Storz 25 (D) - DS <sup>1</sup>	3/D-050 AL	½	31
Storz 25 (D) - DS <sup>1</sup>	3/D-075 AL	¾	31
Storz 25 (D) - DS <sup>1</sup> = DIN14306	3/D-100 AL	1	31
Storz 32 - DS <sup>1</sup>	3/32-100 AL	1	44
Storz 32 - DS <sup>1</sup>	3/32-125 AL	1¼	44
Storz 38 - DS <sup>1</sup>	3/38-150 AL	1½	52
Storz 38 - DS <sup>1</sup>	3/38-200 AL	2	52
Storz 52 (C)	3/C-100 AL	1	66
Storz 52 (C)	3/C-125 AL	1¼	66
Storz 52 (C)	3/C-150 AL	1½	66
Storz 52 C = DIN14307	3/C-200 AL	2	66
Storz 52 (C)	3/C-250 AL	2½	66
Storz 65	3/65-200 AL	2	81
Storz 65	3/65-250 AL	2½	81
Storz 75 (B)	3/B-200 AL	2	89
Storz 75 B = DIN 14308 2½" 89 Aluminium Alloy	3/B-250 AL	2½	89
Storz 75 (B)	3/B-300 AL	3	89
Storz 90	3/90-300 AL	3	105
Storz 100 - DS <sup>1</sup>	3/100-400 AL	4	115
Storz 110 (A)	3/A-400 AL	4	133
Storz 110 A = DIN 14309	3/A-450 AL	4½	133
Storz 125	3/125-500 AL	5	148
Storz 150 = F (3 Claws) Forged	3/150-600 AL	6	160
Storz 165	3/165-600 AL	6	188
Storz 165	3/165-700 AL	7	188
Storz 205	3/205-800 AL	8	220

<sup>1</sup> DS - Suitable for both pressure and suction couplings

#### Male (BSPP)

Nominal Sizes DIN ISO 228	Part No.	Pipe Thread (inch)	KA (mm)
Storz 25 (D) - DS <sup>1</sup>	4/D-100 AL	1	31
Storz 32 DS <sup>1</sup>	4/D-32-100 AL	1	44
Storz 32 DS <sup>1</sup>	4/32-125 AL	1¼	44
Storz 38 - DS <sup>1</sup>	4/38-150 AL	1½	52
Storz 52 (C)	4/C-125 AL	1¼	66
Storz 52 (C)	4/C-200 AL	2	66
Storz 75(B)	4/B-250 AL	2½	89
Storz 75(B)	4/B-300 AL	3	89
Storz 110(A)	4/A-400 AL	4	133

<sup>1</sup> DS - Suitable for both pressure and suction couplings

## Storz Caps

Design:		• Blank cap with chain	
Nominal Sizes DIN ISO 228	Part No.	KA (mm)	
Storz 25 D - DS <sup>1</sup> = DIN 14310	8/D AL	31	
Storz 32 DS <sup>1</sup>	8/32 AL	44	
Storz 38 DS <sup>1</sup>	8/38 AL	52	
Storz 52 C = DIN 14311	8/C AL	66	
Storz 65	8/65 AL	81	
Storz 75 B = DIN 14312	8/B AL	89	
Storz 90	8/90 AL	105	
Storz 100 - DS <sup>1</sup>	8/100 AL	115	
Storz 110 A = DIN 14313	8/A AL	133	
Storz 125	8/125 AL	148	
Storz 150 = F (3 Claws) forged	8/150 AL	160	
Storz 165	8/165 AL	188	
Storz 205	8/205 AL	220	

<sup>1</sup> DS - Suitable for both pressure and suction couplings

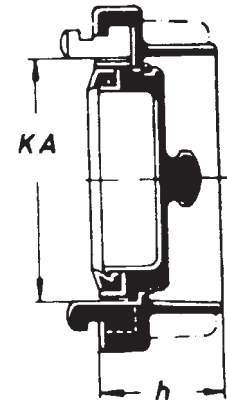

## Storz Couplings Suction Type

Grooved					
Nominal Sizes DIN ISO 228	Part No.	D (mm)	KA (mm)	L (mm)	
Storz 25 (D) = DIN 14301	2/D-25 AL	25	31	50	
Storz 32	2/32-19 AL	19	44	65	
Storz 32	2/32-25 AL	25	44	65	
Storz 32	2/32-32 AL	32	44	75	
Storz 38	2/38-38 AL	38	52	75	
Storz 52	2/C-32 AL	32	66	90	
Storz 52	2/C-38 AL	38	66	90	
Storz 52 (C)	2/C-45 AL	45	66	90	
Storz 52 (C) = DIN14321	2/C-52 AL	52	66	90	
Storz 52 (C)	2/C-60 AL	60	66	125	
Storz 65	2/65-65 AL	65	81	90	
Storz 75 (B)	2/B-65 AL	65	89	125	
Storz 75 (B)	2/B-70 AL	70	89	95	
Storz 75 (B) = DIN 14322	2/B-75 AL	75	89	125	
Storz 75 (B)	2/B-80 AL	80	89	135	
Storz 90	2/90 AL	90	105	150	
Storz 100	2/100 AL	100	115	120	
Storz 110 (A)	2/A-100 AL	100	133	170	
Storz 110 (A) = DIN 14323	2/A-110 AL	110	133	170	
Storz 125	2/125 AL	125	148	196	
Storz 135	2/135-135 AL	135	159	196	
Storz 150 = F (3 Claws) Forged	2/150-150 AL	150	160	180	
Storz 165	2/165-150 AL	150	188	275	
Storz 205	2/205 AL	205	220	375	

Rubber seals (suitable for petrol and oil fluids)

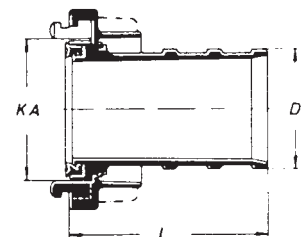

## Storz Reducers

B

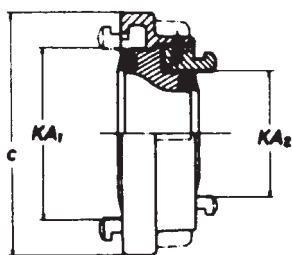
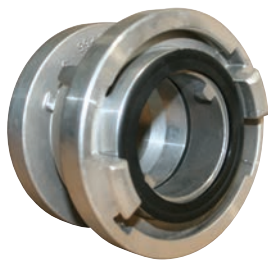

### Swivel

Nominal Sizes DIN ISO 228	Part No.	KA (mm)
C - D = DIN 14341	7/C-D AL	66/31
B - C = DIN 14342	7/B-C AL	89/66
A - A = DIN 14343	7/A-B AL	133/89

### Rigid

Nominal Sizes DIN ISO 228	Part No.	KA (mm)
Storz C-38	7/C-38 AL	66/52
Storz C-32	7/C-32 AL	66/44
Storz 65-C	7/65-C AL	81/66
Storz B-65	7/B-65 AL	89/81
Storz 90-B	7/90-B AL	105/89
Storz 100-B	7/100-B AL	115/89
Storz A-100	7/A-100 AL	133/115
Storz 125-A	7/125-A AL	148/133
Storz 150-A	7/150-A	160/133

## Storz Spanners



### Materials:

- Steel; brass and cast iron available upon request

For Storz Sizes (inch)	Part No.
1 - 3	STZSPAN1-3
2 - 3	STZSPAN2-3
2 - 4	STZSPAN2-4

## King™ Safety Whipsock

<b>Application:</b>	<ul style="list-style-type: none"> <li>Ideally suited for applications where the media being transferred is under higher working pressures such as air, water, hydraulic, and slurry</li> </ul>
<b>Features:</b>	<ul style="list-style-type: none"> <li>King™ Safety Whipsocks keep the hose under control in the event of a high-pressure hose assembly failure</li> <li>Galvanised steel woven stockings extend down the hose to grip securely over a larger area preventing whip, abrasion, and wear</li> <li>Contact Dixon™ with questions regarding working pressure, available options, or custom configurations</li> <li>Securing both eye-to-rigid or eye-to-eye anchor points reduces whip in the event of a hose connection failure</li> </ul>
<b>Materials:</b>	<ul style="list-style-type: none"> <li>Wire rope: galvanised carbon steel</li> <li>Ferrules: aluminium</li> </ul>



KSW32

B



KSW40

Size (inch)	Hose ID (mm)	Length (mm)	Recommended Working Pressure (PSI)	Part No.
3/8	0.8 - 1.4	40	5000	KSW06
1/2	1.4 - 2.0	55	3000	KSW08
3/4	2.0 - 3.0	64	2000	KSW12
1	3.0 - 4.0	87	1500	KSW16
1 1/4	4.0 - 5.0	97	1000	KSW20
1 1/2	5.0 - 6.0	125	700	KSW24
2	6.0 - 7.0	130	1300	KSW32
2 1/2	7.0 - 8.5	135	800	KSW40
3	8.5 - 10.0	184	750	KSW48
3 1/2	10.0 - 12.0	183	550	KSW56
4	12.0 - 14.0	220	550	KSW64
6	14.0 - 18.0	237	250	KSW96



- Dual anchor points secured beyond the fittings eliminate hose whip
- Be sure the anchoring points are rated for the application

## King™ Safety Shackles

<b>Application:</b>	<ul style="list-style-type: none"> <li>Two shackles are used to anchor the King™ Safety Whipsock</li> <li>Securing both eyes to a rigid anchor point to reduce whip in the event of a hose or connection failure</li> </ul>
---------------------	---

Size (inch)	Working Load	Fits KSW Eye	Micro Alloy Steel Part No.
5/16 (8mm)	3/4 ton (1000 lbs)	KSW06-KSW12	KSS04
7/16 (11mm)	1 1/2 ton (3000 lbs)	KSW16-KSW40	KSS06
5/8 (15mm)	3 1/4 ton (6000 lbs)	KSW48-KSW96	KSS08





- Recommended bolt, nut, and cotter pin style shackle
- Caution: working load must be rated for the application

# Industrial Hose Fittings

## King Cable™

<b>Application:</b>	<ul style="list-style-type: none"> <li>• These strong steel cables prevent hose whip in case of accidental separation of coupling or clamp device. King Cable™ reaches across the hose fittings to provide standby safety for hose. Spring-loaded loops in the cable ends open easily to pass over the couplings for a firm grip on the hose. Thoroughly tested with years of service.</li> </ul>
<b>Features:</b>	<ul style="list-style-type: none"> <li>• Must be installed in the extended position (no slack)</li> <li>• Use King Cable™ to help prevent accidents or injuries resulting from hose or coupling failure</li> <li>• A positive safeguard for air hose connections - helps you meet today's safety standards</li> <li>• Cable reaches across hose fittings to provide standby safety for hose</li> <li>• Spring-loaded loops open easily to pass over the couplings for a firm grip on the hose</li> <li>• No tools needed - easy to install and remove</li> <li>• Cables shipped with safety restraint labels attached</li> <li>• Highly resistant to rust and corrosion</li> <li>• Hose-to-hose or hose-to-rigid outlet</li> <li>• Maximum operating pressure: <b>200 PSI</b></li> <li>• Minimises damage to equipment and injuries to operators in the event hose, couplings, or clamps fail, or there is an accidental separation of the assembly</li> </ul>
<b>Materials:</b>	<ul style="list-style-type: none"> <li>• Galvanised steel wire rope, aluminium ferrules, galvanised carbon steel springs</li> </ul>

Hose End



Tool End

Style WSR for Hose-to-Tool Service

Cable (mm)	Hose ID (mm)	Length (mm)	Steel	316 Stainless Steel
			Part No.	Part No.
3	13 - 32	515	WSR1	WSR1SS
5	13 - 50	712	WSR3	---
6	38 - 75	956	WSR2	WSR2SS
10	100	1118	WSR4	---

Hose End



Hose End

Style WSR for Hose-to-Hose Service

Cable (mm)	Hose ID (mm)	Length (mm)	Steel	316 Stainless Steel
			Part No.	Part No.
3	13 - 32	515	WB1	WB1SS
5	13 - 50	712	WB3	---
6	38 - 75	956	WA2	WA2SS
10	100	1118	WA4	---



WSR1E

Other King Cable™ Options

Cable (mm)	Part No.	Description	Materials
3	WSR1E	WSR1 with stainless steel safety marine eye used to connect safety cable to a bolt on tool.	galvanised carbon steel wire rope, aluminium ferrules, galvanised carbon steel springs



## Nylon King Cable™

<b>Application:</b>	<ul style="list-style-type: none"> <li>Pneumatic, hydraulic, and water hoses</li> </ul>
<b>Features:</b>	<ul style="list-style-type: none"> <li>Strong, flexible nylon webbing</li> <li>Superior corrosion and spark resistance over metal restraints</li> <li>Rubber grommets securely choke eyes around hose</li> <li>Must be installed in the extended position (no slack)</li> <li>Shipped with labels detailing working pressures and safety instructions</li> <li>Maximum working temperature: <b>93°C (200°F)</b></li> <li>Minimises damage to equipment and injuries to operators in the event hose, couplings, or clamps fail, or there is an accidental separation of the assembly</li> <li>Contact Dixon™ on +44 (0)1772 323529 for additional options</li> </ul>
<b>Materials:</b>	<ul style="list-style-type: none"> <li>Strap: nylon</li> <li>Grommets: rubber</li> </ul>

Length (inch)	Recommended for use on the following hose inside diameters:								Nylon Part No.
	¼"	½"	¾"	1"	2"	3"	4"	6"	
30	26,000	6,500	2,900	1,650	400	---	---	---	WBN130
40	---	---	---	1,650	400	175	100	---	WBN140
30	52,000	13,000	5,800	3,300	750	---	---	---	WBN230
64	---	---	---	---	750	350	200	90	WBN264
44	---	---	---	7,300	1,800	820	450	---	WBN344
64	---	---	---	---	2,300	1,040	580	260	WBN464



## ASME Air Receiver Manifold

<b>Features:</b>	<ul style="list-style-type: none"> <li>Built to ASME Code, National Board registered</li> <li>Conforms to OSHA standards 1910.169 and 1926.306</li> <li>7-gallon capacity</li> <li>Painted safety orange</li> <li>All openings are female NPT thread</li> <li>Working pressure: <b>200 PSI</b></li> </ul>
------------------	---



1217AR-4AK

Dixon™ 1217AR-4AK air receiver manifold assembly with Air King™ outlet ports includes the following components:

Description	Qty	Part No. / Location
ASME compressed air receiver	1	1217AR-4
protective frame	1	1217FRAME
3731204C ¾" male x ¼" female hex bushing	1	Location 1
GL345 0-300 PSI gauge	1	
3730804C ½" male x ¼" female hex bushing	1	Location 2
SV200 safety pop-off valve	1	
GM28 2" male spud	1	Location 3
B27SC wing nut cap	1	
HB1075G 1" male x ¾" female bushings	6	Locations
3701212C ¾" brass hex nipples	6	4, 5, 6, 9,
BBLV75 ball valves	6	10, 11
SCVS6 safety shut-off valves	6	
AM7 Air King™ universal couplings	6	
SE45100 45° street elbow (1 each in locations 4, 6, 9 and 11 only)	4	
HB2075 2" male x ¾" female bushing	1	Location 7
3701212C ¾" brass hex nipples	1	
BBLV75 ball valve	1	
SCVS6 safety shut-off valve	1	
AM7 Air King™ universal coupling	1	
3730804C ½" male x ¼" female hex bushing	1	Location 8
D04 ¼" drain cock	1	
Labor cost for assembly of complete unit	---	
7-gallon ASME compressed air receiver manifold complete assembly with Air King™	1	1217AR-4AK
Tank and Frame only		
7-gallon ASME compressed air receiver with frame only	1	1217AR-4FR



1217AR-4FR

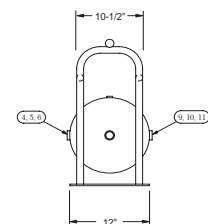
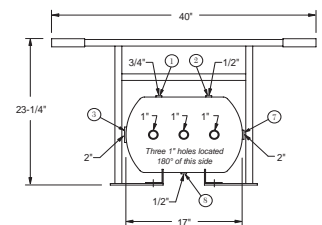

# Industrial Hose Fittings

## In-Line Lubricators



B

NPT Sizes	Oil Capacity (ml)	Max WP PSI	Air Flow at 70 PSI	Part No.
15	40	500	30 scfm	PL300
20	105	200	70 scfm	PL400
20	312.5	300	70 scfm	PL400L
25	454.5	250	100 scfm	PL500

Designed to protect portable or stationary air tools by efficiently oiling the tool mechanisms. Each time an air tool is operated, a fine mist of oil is injected into it along with the air from the compressor. Installation is recommended within 7.5 metres of the tool to be lubricated. Transparent sight disc allows visual inspection of oil level. Oil flow regulated by screwdriver screw adjustment.

### Product Information

**TYPE OF OIL TO USE:** Use any petroleum-base, non-detergent light-weight oil (SAE 10/150SSU) which will readily break up into a mist, i.e., MOBIL DTE light or comparable oil. **DO NOT** use any synthetic oil or oils containing additives or solvents.

**Material:** Aluminium

- Not recommended for constant flow applications
- For reciprocating tools only
- Minimum flow rate is 30 SCFM

## Hose Crimper

**Features:**

- Hose crimper provides "big tool" crimping advantages at a fraction of the cost
- Rugged, portable, and easy to use
- Optional dies up to 21mm (15mm ID hose available)

Crimper With Die		
Part No.	Hose OD Range	Weight (kg)
855	2-17.85 mm	4.08
855A	11-17 mm	4.53

Optional Dies					
Die Part No.	Die Bore (mm)	Hose OD (mm)		Crimper No. 855	Crimper No. 855A
		from	to		
856-1	15.9	16.3	17	Standard	Standard
856-2	14.7	15	15.9	Standard	Standard
856-3	13.5	13.7	14.3	Standard	Standard
856-5	17.4	17.5	18	Standard	Optional
856-7	11.1	11.4	11.9	Optional	Standard
856-8	19.1	19.3	19.8	Optional	Optional
856-9	20.6	20.8	21.4	Optional	Optional
856-10	9.5	9.8	10.3	Optional	Optional



## 860 Large Hose Crimper

**Features:**

- For crimping larger hoses from 22 mm to 40 mm OD
- Crimps standard brass or aluminium ferrules
- Sold without dies
- Order separate dies for each hose diameter

Part No.
860

Die Part No.	Hose OD			Finished Crimp Dimension (inch)
	OD (mm)	From (inch)	To (inch)	
861-22	17.5	0.687	0.765	11/16
861-23	18.3	0.718	0.796	23/32
861-24	19.1	0.750	0.828	3/4
861-25	19.8	0.781	0.860	25/32
861-26	20.6	0.812	0.890	13/16
861-27	21.4	0.843	0.921	27/32
861-28	22.2	0.875	0.953	7/8
861-29	23.0	0.906	0.985	29/32
861-30	23.8	0.937	1.010	15/16
861-31	24.6	0.968	1.040	31/32
861-32	25.4	1.000	1.070	1
861-33	26.2	1.031	1.110	1-1/32
861-34	27.0	1.062	1.114	1-1/16
861-36	28.6	1.125	1.208	1-1/8
861-38	30.2	1.187	1.265	1-3/16
861-40	31.8	1.250	1.321	1-1/4
861-42	33.3	1.312	1.390	1-5/16
861-46	36.5	1.437	1.551	1-7/16
861-48	38.1	1.500	1.578	1-1/2



## Brass Ferrule Crimper - Air Operated



The mass production assembly of hose, ferrules, and fittings is efficiently handled with this air-operated unit. Foot pedal permits the use of both hands, reduces fatigue, and speeds production. Complete with air cylinder, ferrule machine (fewer dies), fitted hose lengths, and necessary control valves. Ready for work bench installation. Crimps all ferrules shown.

Part No.

1765A

## Brass Ferrule Crimper - Manually Operated



### Specifications:

- Crimps all ferrules shown
- Does not include dies
- Refer to page 60 for dies

Part No.	Base (mm)	Body (mm)	Height (mm)	Weight
5111A	200 x 75	185	685	12 kgs

## Brass Ferrules - for Fluid

### Application:

- For use with general purpose barbed hose tails. Working pressure will depend on hose, hosetail, and ferrule combination. If exact pressure is required contact a Dixon Europe representative regarding testing.

### Ferrule Selection:

- Measure hose free OD (outside diameter) with a diameter tape. Select the correct brass ferrule from the table. The correct ID (Inside Diameter) should not exceed 0.8 mm (1/32") above the hose OD just measured.

### Crimping:

- Ensuring a square cut hose end, slide the ferrule over the hose. Using lubricant on the hose ID and stem OD fully insert the stem into the hose. Select the proper die needed from the table according to your hose OD just measured. Open hose crimper slide fitting into hose crimper, centering the ferrule in the proper die. Crimp the hose.



Part No.	Ferrule ID (mm)	Ferrule Length (mm)	End Hole Size (mm)	Metal Gauge	Standard Industrial Part No.	Ribbed Die** Part No.	Plain Die** Part No.	Pkg Qty
BF825	20.95	21.43	17.48	.610	---	R27	P28	25
BF850	21.59	14.43	15.88	.483	Z	R26	P27	25
BF875	22.22	21.43	17.48	.610	7244A	R25	P26	25
BFW875	22.23	21.41	17.48	.610	7244A	R25	P26	25
BFW900	22.86	21.41	17.48	.610	5029A	R24	P25	25
BFW925	23.79	21.43	17.48	.610	7242A	R23	P24	25
BFW975	24.77	21.41	17.48	.610	5028A	R21	P22	25
BFW1025	26.04	21.41	17.60	.610	7114A	R19	P20	25
BFW1175	29.85	21.41	22.23	.610	7088A	R13	P14	25
BFMW1050	26.67	15.75	19.05	.635	7145	R18	P19	25
BFMW1100	27.94	21.41	20.62	.584	5027	R16	P17	25
BFMW1150	29.21	21.43	22.22	.610	7104A	R15	P15	25
BFMW1225	31.12	22.23	22.23	.635	875-K	R11	P12	25
BFMW1275	32.39	22.23	25.40	.635	875-K	R9	P10	25
BFMW1400	35.56	17.45	28.45	.508	D	R4	P5	25
BFMW1500	38.10	22.23	28.45	.635	1500	-	P1	25

\*\* These dies for use with 5111A and ferrule machine.

\* Sold in bag quantities only.

Dies for ferrule machines are available in standard sets for all ferrules as tabulated (four segments to a set). Dies are supplied with plain or ribbed crimping surface. Refer to table for die part numbers.

## Brass Ferrules - for Air

<b>Application:</b>	<ul style="list-style-type: none"> <li>For use with general purpose barbed hose tails. Working pressure will depend on hose, hosetail and ferrule combination. If exact pressure is required contact a Dixon Europe representative regarding testing.</li> </ul>
<b>Ferrule Selection:</b>	<ul style="list-style-type: none"> <li>Measure hose free OD (outside diameter) with a diameter tape. Select the correct brass ferrule from the table. The correct ID (Inside Diameter) should not exceed 0.8 mm (1/32") above the hose OD just measured.</li> </ul>
<b>Crimping:</b>	<ul style="list-style-type: none"> <li>Ensuring a square cut hose end, slide the ferrule over the hose. Using lubricant on the hose ID and stem OD fully insert the stem into the hose. Select the proper die needed from the table according to your hose OD just measured. Open hose crimper and slide fitting into hose crimper, centering the ferrule in the proper die. Crimp the hose.</li> </ul>

Part No.	Ferrule ID (mm)	Ferrule Length (mm)	End Hole Size (mm)	Metal Gauge	Standard Industrial Part No.	Ribbed Die** Part No.	Plain Die** Part No.	Pkg Qty
<b>BFM for Medium Weight Hose</b>								
BFM478	12.14	17.46	8.33	.610	4750	R39	P40	50
BFM500	12.70	25.40	8.74	.610	7332	R40	P40	50
BFM531	13.41	25.40	9.52	.610	7323	R39	P39	50
BFM562	14.27	25.40	11.11	.610	7325	R37	P38	50
BFM593	15.06	25.40	11.11	.610	7326	R36	P37	50
BFM625	15.88	25.40	11.11	.610	7327	R35	P36	50
BFM656	16.66	25.40	11.11	.610	7328	R34	P35	50
BFM687	17.45	25.40	12.70	.610	7329	R33	P34	50
BFM718	18.24	25.40	15.88	.610	7330	R31	P32	50
BFM718B	18.24	25.40	12.70	.610	7330B	R31	P32	50
BFM750	19.05	25.40	15.88	.610	7331	R30	P31	50
BFM750B	19.05	25.40	12.70	.610	7331B	R30	P31	50
BFM781	19.84	25.40	15.88	.610	7332	R29	P30	50
BFM781B	19.84	25.40	12.70	.610	7332B	R29	P30	50
BFM812	20.62	25.40	15.87	.610	7333	R28	P28	50
<b>BFL for Light Weight Hose</b>								
BFL410	10.41	12.70	6.75	.406	620	R41	P42	50
BFL450	11.43	14.29	8.73	.406	769	R41	P42	50
BFL548	13.92	12.30	9.53	.381	626	R38	P39	50
BFL500	12.70	12.70	8.73	.406	624	R40	P41	50
BFL525	13.34	12.70	8.73	.406	625	R39	P40	50
BFL564	14.33	19.05	9.53	.483	3588	R37	P38	50
BFL575	14.61	12.30	11.91	.483	KK	R37	P38	50
BFL600	15.24	12.70	12.70	.483	JJ	R36	P37	50
BFL625	15.88	12.70	12.70	.483	II	R35	P36	50
BFL650	16.51	12.70	12.70	.483	HH	R34	P35	50
BFL675	17.14	13.10	12.70	.482	GG	R34	P34	50
BFL725	18.42	13.49	12.70	.483	EE	R31	P32	50
BFL750	19.05	13.49	12.70	.483	DD	R30	P31	50
BFL775	19.68	13.48	12.70	.406	CC	R31	P31	50

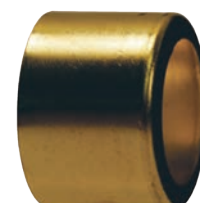

\*\* These dies for use with 5111A and ferrule machine.  
 \* Sold in bag quantities only.

Dies for ferrule machines are available in standard sets for all ferrules as tabulated (four segments to a set). Dies are supplied with plain or ribbed crimping surface. Refer to table for die part numbers.

# Industrial Hose Fittings

## Ribbed and Plain Dies

B



P29



R28

Ferrule ID (inch)	Standard Industrial Part No.	Bore/Crimp Diameter <sup>1</sup>	Ribbed Die	Plain Die
.478	4750	0.450	R41	P42
.500	7322	0.475	R40	P40
.528	7323	0.500	R39	P39
.528	7324	0.500	R39	P39
.562	7325	0.525	R37	P38
.593	7326	0.550	R36	P37
.625	7327	0.575	R35	P36
.656	7328	0.600	R34	P35
.687	7329	0.625	R33	P34
.718	7330	0.675	R31	P32
.718	7330B	0.675	R31	P32
.750	7331	0.700	R30	P31
.750	7331B	0.700	R30	P31
.781	7332	0.725	R29	P30
.781	7332B	0.725	R29	P30
.812	7333	0.750	R28	P29
.380	622	0.350	R44	P45
.400	619	0.375	R44	P44
.410	620	0.375	R43	P44
.450	769	0.425	R41	P42
.500	624	0.450	R40	P41
.525	625	0.475	R39	P40
.548	626	0.500	R38	P39
.564	3588	0.525	R37	P38
.575	KK	0.525	R37	P38
.600	JJ	0.550	R36	P37
.625	II	0.575	R35	P36
.650	HH	0.600	R34	P35
.675	GG	0.625	R34	P34
.725	EE	0.675	R31	P32
.750	DD	0.675	R30	P32
.775	CC	0.700	R31	P31
.800	---	0.750	R28	P29
.825	---	0.775	R27	P28
.850	Z	0.800	R26	P27
.875	7244A	0.825	R25	P26
.900	5029A	0.850	R24	P25
.937	7242A	0.875	R23	P24
.975	5028A	0.925	R21	P22
1.025	7114A	0.975	R19	P20
1.175	7088A	1.125	R13	P14
1.050	3605	1.000	R18	P19
1.100	5027A	1.050	R16	P17
1.150	7104A	1.100	R15	P15
1.225	875-K	1.175	R11	P12
1.275	875-I	1.225	R9	P10
1.400	D	1.350	R4	P5
1.500	1500	1.450	---	P1

<sup>1</sup> Plain die bore diameter can be used as crimp spec  $\pm 0.005$

• Dies for use with 5111A and 1765A ferrule machines. Other sizes are available.

## Male NPTF x Hose Barb

Hose ID (inch)	Male NPTF (inch)	Brass		316 Stainless Steel <sup>1</sup> Part No.	Pkg Qty
		Previous Part No.	Part No.		
1/8	1/8	BN11	1020202C	RN11	100
	1/4	BN122	1020204C	---	100
3/16	1/8	BN151	1020302C	RN151	100
	1/4	BN152	1020304C	RN152	100
1/4	1/8	BN21	1020402C	RN21	100
	1/4	BN22	1020404C	RN22	100
	3/8	BN23	1020406C	RN23	100
	1/2	BN24	1020408C	---	50
5/16	1/8	BN251	1020502C	RN251	100
	1/4	BN252	1020504C	RN252	50
	3/8	BN253	1020506C	RN253	50
3/8	1/8	BN31	1020602C	RN31	100
	1/4	BN32	1020604C	RN32	100
	3/8	BN33	1020606C	RN33	50
	1/2	BN34	1020608C	RN34	25
	3/4	BN36	1020612C	---	25
1/2	1/4	BN42	1020804C	RN42	50
	3/8	BN43	1020806C	RN43	50
	1/2	BN44	1020808C	RN44	25
	3/4	BN46	1020812C	RN46	25
5/8	3/8	BN53	1021006C	RN53	50
	1/2	BN54	1021008C	RN54	25
	3/4	BN56	1021012C	RN56	25
3/4	1/2	BN64	1021208C	RN64	25
	3/4	BN66	1021212C	RN66	20
1	3/4	BN86	1021612C	RN86	20
	1	BN88	1021616C <sup>2</sup>	RKHN881 <sup>3</sup>	10
1 1/4	3/4	BN106	1022012C	---	10
	1	BN108	1022016C <sup>2</sup>	---	5

<sup>1</sup> NPT thread

<sup>2</sup> Capped

<sup>3</sup> Same shank style as KHN881

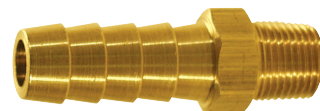

brass



316 stainless steel



## Male NPTF x Beaded Hose Barb

Hose ID (inch)	Male NPTF (inch)	Brass Part No.	Pkg Qty
1/4	1/8	268B0402	100
	1/4	268B0404	100
5/16	1/8	268B0502	100
	1/4	268B0504	50
3/8	1/8	268B0602	100
	1/4	268B0604	100
	3/8	268B0606	50
1/2	3/8	268B0806	50
	1/2	268B0808	50
5/8	1/2	268B1008	25
3/4	1/2	268B1208	50
	3/4	268B1212	25



## Male BSPT x Hose Barb

Hose ID (inch)	Male BSPT (inch)	Brass		Pkg Qty
		Previous Part No.	Part No.	
1/4	1/8	BN21BSPT	1020402BSPT	100
	1/4	BN22BSPT	1020404BSPT	100
3/8	1/4	BN32BSPT	1020604BSPT	100
	3/8	BN33BSPT	1020606BSPT	50
	1/2	BN34BSPT	1020608BSPT	25
1/2	3/8	BN43BSPT	1020806BSPT	50
	1/2	BN44BSPT	1020808BSPT	50
3/4	3/4	BN66BSPT	1021212BSPT	25
1	1	BN88BSPT	1021616BSPT	10



# Industrial Hose Fittings

## Female NPTF x Hose Barb

B



brass

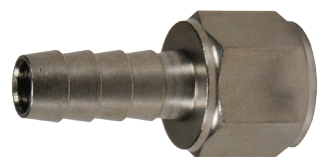

303 stainless steel

Hose ID (inch)	Female NPTF (inch)	Brass		303 Stainless Steel <sup>1</sup>		Pkg Qty
		Previous Part No.	Part No.	Previous Part No.	Part No.	
1/8	1/8	BF11	1040202C	---	---	100
	1/4	BF12	1040204C	---	---	100
3/16	1/8	BF151	1040302C	---	---	100
	1/4	BF152	1040304C	---	---	100
1/4	1/8	BF21	1040402C	---	---	100
	1/4	BF22	1040404C	BF22SS	1040404SS	100
	3/8	BF23	1040406C	---	---	50
	1/2	BF24	1040408C	---	---	50
5/16	1/8	BF251	1040502C	---	---	100
	1/4	BF252	1040504C	---	---	100
	3/8	BF253	1040506C	---	---	100
3/8	1/8	BF31	1040602C	---	---	100
	1/4	BF32	1040604C	BF32SS	1040604SS	50
	3/8	BF33	1040606C	BF33SS	1040606SS	50
	1/2	BF34	1040608C	---	---	50
1/2	3/4	BF36	1040612C	---	---	25
	1/4	BF42	1040804C	---	---	50
	3/8	BF43	1040806C	---	---	50
5/8	1/2	BF44	1040808C	BF44SS	1040808SS	50
	3/4	BF46	1040812C	---	---	25
	3/8	BF53	1041006C	---	---	50
3/4	1/2	BF54	1041008C	---	---	25
	3/4	BF56	1041012C	---	---	25
1	1/2	BF64	1041208C	---	---	25
	3/4	BF66	1041212C	---	---	20
1	3/4	BF86	1041612C	---	---	20
	1	BF88	1041616C	---	---	10
1 1/4	1	BF108	1042016C	---	---	10

<sup>1</sup> NPT threads and are packaged to order

## Female NPSM Swivel x Hose Barb Ball Seat



Hose ID (inch)	Female NPSM (inch)	Brass		Pkg Qty
		Previous Part No.	Part No.	
1/8	1/8	BFS11	1240202K	100
3/16	1/8	BFS151	1240302K	100
	1/4	BFS152	1240304K	100
1/4	1/8	BFS21	1240402K	100
	1/4	BFS22	1240404K	100
5/16	3/8	BFS23	1240406K	100
	1/4	BFS252	1240504K	100
3/8	3/8	BFS253	1240506K	50
	1/4	BFS32	1240604K	100
1/2	3/8	BFS33	1240606K	100
	1/2	BFS34	1240608K	100
3/4	3/8	BFS43	1240806K	50
	1/2	BFS44	1240808K	100
1	3/4	BFS66	1241212K	50



## Male NPTF x Hose Barb 90° Elbow

Hose ID (inch)	Male NPTF (inch)	Brass	
		Previous Part No.	Part No.
3/16	1/8	EL15H1M	1290302C
	1/8	EL2H1M	1290402C
1/4	1/4	EL2H2M	1290404C
	3/8	EL2H3M	1290406C
5/16	1/8	EL25H1M	1290502C
	1/4	EL25H2M	1290504C
	3/8	EL25H3M	1290506C
3/8	1/8	EL3H1M	1290602C
	1/4	EL3H2M	1290604C
	3/8	EL3H3M	1290606C
	1/2	EL3H4M	1290608C
1/2	1/4	EL4H2M	1290804C
	3/8	EL4H3M	1290806C
5/8	1/2	EL4H4M	1290808C
	3/8	EL5H3M	1291006C
3/4	1/2	EL5H4M	1291008C
	3/4	EL6H4M	1291208C
1	3/4	EL6H6M	1291212C
	1	EL8H6M	1291612C
		EL8H8M	1291616C <sup>1</sup>

<sup>1</sup> Capped



B

Hose ID (inch)	Male NPT (inch)	316 Stainless Steel		Pkg Qty
		Previous Part No.	Part No.	
1/4	1/8	EL2H1MSS	1290402SS	50
	1/4	EL2H2MSS	1290404SS	50
3/8	1/4	EL3H2MSS	1290604SS	50
	3/8	EL3H3MSS	1290606SS	50
1/2	1/4	EL4H2MSS	1290804SS	50
	3/8	EL4H3MSS	1290806SS	50
	1/2	EL4H4MSS	1290808SS	25
3/4	1/2	EL6H4MSS	1291208SS	25
	3/4	EL6H6MSS	1291212SS	25



## Barbed 90° Elbow Splicers

Hose ID (inch)	Brass		304 Stainless Steel		Pkg Qty
	Previous Part No.	Part No.	Previous Part No.	Part No.	
1/8	177-0202	1770202C	177-0202SS	1770202SS	25
3/16	177-0303	1770303C	177-0303SS	1770303SS	25
1/4 x 1/8	177-0402	1770402C	---	---	25
1/4	177-0404	1770404C	177-0404SS	1770404SS	25
5/16	177-0505	1770505C	---	---	25
3/8 x 1/4	177-0604	1770604C	---	---	25
3/8	177-0606	1770606C	177-0606SS	1770606SS	25
1/2 x 3/8	177-0806	1770806C	---	---	25
1/2	177-0808	1770808C	177-0808SS	1770808SS	25
5/8	177-1010	1771010C	---	---	25
3/4 x 1/2	177-1208	1771208C	---	---	25
3/4	177-1212	1771212C	---	---	25



brass



304 stainless steel

# Industrial Hose Fittings

## Barbed Tee Splicers

B



brass



brass with male NPTF

Hose ID (inch)	Brass		Pkg Qty
	Previous Part No.	Part No.	
1/8	179-0202	1790202C	25
3/16	179-0303	1790303C	100
1/4 x 1/8	179-0402	1790402C	25
1/4	179-0404	1790404C	25
5/16	179-0505	1790505C	25
3/8 x 1/4	179-0604	1790604C <sup>1</sup>	25
3/8 x 1/4	---	1790604BARB	25
3/8	179-0606	1790606C	25
1/2 x 3/8	179-0806	1790806C	25
1/2	179-0808	1790808C	25
5/8	179-1010	1791010C	25
3/4 x 1/2	179-1208	1791208C	25
3/4	179-1212	1791212C	20

<sup>1</sup> Drop leg has 1/4"-18 male NPTF thread



304 stainless steel

Hose ID (inch)	304 Stainless Steel		Pkg Qty
	Previous Part No.	Part No.	
1/8	179-0202SS	1790202SS	
3/16	179-0303SS	1790303SS	
1/4	179-0404SS	1790404SS	
3/8	179-0606SS	1790606SS	
1/2	179-0808SS	1790808SS	

## Male NPTF x Hose Barb 45° Elbow



Hose ID (inch)	Male NPTF (inch)	Brass		Pkg Qty
		Previous Part No.	Part No.	
1/4	1/8	139-0402	1390402C	100
	1/4	139-0404	1390404C	25
3/8	1/8	139-0602	1390602C	100
	1/4	139-0604	1390604C	100
1/2	3/8	139-0606	1390606C	25
	1/4	139-0804	1390804C	25
1/2	3/8	139-0806	1390806C	25
	1/2	139-0808	1390808C	25
3/4	1/2	139-1208	1391208C	25

## Male 45° SAE x Hose Barb



Hose ID (inch)	Male UNF (inch)	Brass		Pkg Qty
		Previous Part No.	Part No.	
3/16	7/16-20	142-0307	1420307C	100
	7/16-20	142-0407	1420407C	100
1/4	5/8-18	142-0410	1420410C	100
	1/2-20	142-0508	1420508C	100
3/8	5/8-18	142-0610	1420610C	50
	3/4-16	142-0612	1420612C	50
1/2	3/4-16	142-0812	1420812C	50

## Female 45°SAE/37°JIC Swivel x Hose Barb

Hose ID (inch)	Tube OD (inch)	Female UNF (inch)	Brass		Pkg Qty
			Previous Part No.	Part No.	
3/16	1/4	7/16-20	143-0307	1430307K	100
1/4	1/4	7/16-20	143-0407	1430407K	100
	1/4	7/16-20	---	1430407KLF <sup>1</sup>	---
5/16	5/16	1/2-20	143-0408	1430408K	100
	5/16	1/2-20	143-0508	1430508K	50
3/8	1/2	3/4-16	143-0612	1430612K	100
1/2	1/2	3/4-16	143-0812	1430812K	100
	5/8	7/8-14	143-0814	1430814K	50



## Female 45° SAE Swivel x Hose Barb

Hose ID (inch)	Tube OD (inch)	Female UNF (inch)	Brass		Pkg Qty
			Previous Part No.	Part No.	
3/16	3/16	3/8-24	144-0306	1440306K	100
1/4	3/8	5/8-18	144-0410	1440410K	100
5/16	3/8	5/8-18	144-0510	1440510K	100
3/8	3/8	5/8-18	144-0610	1440610K	100
1/2	1/2	3/4-16	144-0812	1440812K	100
3/4	3/4	1-1/16-14	144-1217	1441217K <sup>1</sup>	25



<sup>1</sup> Notch in nut for SAE identification

## Female 37° JIC Swivel x Hose Barb

Hose ID (inch)	Tube OD (inch)	Female UNF (inch)	Brass		Pkg Qty
			Previous Part No.	Part No.	
3/8	3/8	9/16-18	145-0609	1450609K	100
1/2	1/2	1-1/16-12	145-1217	1451217K	25



## Female PTF-SAE Short Swivel x Hose Barb

Hose ID (inch)	Female PTF-SAE Short (inch)	Brass		Pkg Qty
		Previous Part No.	Part No.	
1/4	1/4	105-0404	1050404C	50
3/8	1/4	105-0604	1050604C	50
	3/8	105-0606	1050606C	50
1/2	3/8	105-0806	1050806C	50
	1/2	105-0808	1050808C	25



• Swivel is for assembly convenience only, not for live swivel applications, **120 PSI** maximum

# Industrial Hose Fittings

## Push-On Hose Barb Fittings

### Assembly Instructions:

1. Trim hose end with smooth square cut
2. Lubricate either push-on fitting, hose, or both.
3. Insert push-on fitting into hose until first barb is in hose.
4. Place end of fitting against a flat object (bench, wall, etc.) and grip the hose one inch from end. Push with a steady force until end of hose is covered by yellow plastic cap.

### Disassembly Instructions:

1. Leaving push-on fitting in place, make a 1" cut in the hose along the barbed end of the fitting. Note: Be careful not to nick barbs when cutting the hose.
2. With firm grip on hose, give a sharp downward pull to release the fitting from the hose.



- Intended for use with Lok-On (push-on style) hose only
- No hose clamps or ferrules are needed for installation
- Properly grips push-on hose only when pushed all the way in, with the cut end of the hose completely concealed by the plastic cap



brass



brass cap



303 stainless steel



### Male NPTF x Hose Barb

Hose ID (inch)	Male NPTF (inch)	Brass			Brass Cap Option	
		Previous Part No.	Part No.	Pkg Qty	Part No.	Pkg Qty
1/4	1/8	BPN21	2720402C	100	2720402CBC	100
	1/4	BPN22	2720404C	100	2720404CBC	100
	3/8	BPN23	2720406C	50	2720406CBC	50
5/16	1/8	BPN251	2720502C	100	---	---
	1/4	BPN252	2720504C	50	---	---
3/8	1/8	BPN31	2720602C	100	2720602CBC	100
	1/4	BPN32	2720604C	50	2720604CBC	50
	3/8	BPN33	2720606C	50	2720606CBC	50
	1/2	BPN34	2720608C	25	2720608CBC	25
1/2	3/4	BPN36	2720612C	25	2720612CBC	25
	1/4	BPN42	2720804C	25	2720804CBC	25
	3/8	BPN43	2720806C	25	2720806CBC	25
	1/2	BPN44	2720808C	50	2720808CBC	50
	3/4	BPN46	2720812C	50	2720812CBC	50
5/8	3/8	BPN53	2721006C	25	2721006CBC	25
	1/2	BPN54	2721008C	25	2721008CBC	25
	3/4	BPN56	2721012C	25	2721012CBC	25
3/4	1/2	BPN64	2721208C	25	2721208CBC	25
	3/4	BPN66	2721212C	25	2721212CBC	25
1	3/4	BPN86	2721612C	10	---	---
	1	BPN88	2721616C <sup>1</sup>	10	---	---

### Male NPTF x Hose Barb

Hose ID (inch)	Male NPTF (inch)	303 Stainless Steel		
		Previous Part No.	Part No.	Pkg Qty
1/4	1/8	RPN21	2720402SS	100
	1/4	RPN22	2720404SS	100
3/8	1/4	RPN32	2720604SS	50
	3/8	RPN33	2720606SS	50
1/2	1/4	RPN42	2720804SS	25
	3/8	RPN43	2720806SS	50
	1/2	RPN44	2720808SS	25
3/4	1/2	RPN64	2721208SS	25
	3/4	RPN66	2721212SS	20
1	1	RPN88	2721616SS <sup>1</sup>	5

<sup>1</sup> Capped

### Male NPTF Swivel x Hose Barb

Hose ID (inch)	Male NPTF (inch)	303 Stainless Steel		
		Previous Part No.	Part No.	Pkg Qty
1/4	1/8	271-0402	2710402C	100
	1/4	271-0404	2710404C	50
3/8	1/4	271-0604	2710604C	50
	3/8	271-0606	2710606C	50
1/2	3/8	271-0806	2710806C	25
	1/2	271-0808	2710808C	20
3/4	3/4	271-1212	2711212C	10

• Swivel is for assembly convenience only, not for live swivel applications, **120 PSI** maximum

## Push-On Hose Barb Fittings

- Intended for use with Lok-On (push-on style) hose only
- No hose clamps or ferrules are needed for installation
- Properly grips push-on hose only when pushed all the way in, with the cut end of the hose completely concealed by the plastic cap

Male NPTF x Hose Barb 90° Elbow				
Hose ID (inch)	Male NPTF (inch)	Brass		
		Previous Part No.	Part No.	Pkg Qty
¼	¼-27	273-0402	2730402C	100
	¼-18	273-0404	2730404C	50
⅜	⅜-27	273-0602	2730602C	50
	¼-18	273-0604	2730604C	50
	⅜-18	273-0606	2730606C	25
½	⅜-18	273-0806	2730806C	25
	½-14	273-0808	2730808C	25
¾	½-14	273-1208	2731208C	10
	¾-14	273-1212	2731212C	10



B

Female NPTF x Hose Barb				
Hose ID (inch)	Female NPTF (inch)	Brass		
		Previous Part No.	Part No.	Pkg Qty
¼	⅛	BPF21	2740402C	100
	⅛	---	2740402CBC <sup>1</sup>	---
	¼	BPF22	2740404C	100
	¼	---	2740404CBC <sup>1</sup>	---
	⅜	BPF23	2740406C	50
	⅜	---	2740406CBC <sup>1</sup>	---
5/16	⅛	BPF251	2740502C	100
	¼	BPF252	2740504C	50
⅜	⅛	BPF31	2740602C	50
	⅛	---	2740602CBC <sup>1</sup>	---
	¼	BPF32	2740604C	50
	¼	---	2740604CBC <sup>1</sup>	---
	⅜	BPF33	2740606C	50
	⅜	---	2740606CBC <sup>1</sup>	---
	½	BPF34	2740608C	50
	¾	BPF36	2740612C	25
½	¼	BPF42	2740804C	50
	¼	---	2740804CBC <sup>1</sup>	50
	⅜	BPF43	2740806C	50
	⅜	---	2740806CBC <sup>1</sup>	---
	½	BPF44	2740808C	25
	½	---	2740808CBC <sup>1</sup>	---
	¾	BPF46	2740812C	25
	¾	---	2740812CBC <sup>1</sup>	---
⅝	⅜	BPF53	2741006C	25
	½	BPF54	2741008C	25
	½	---	2741008CBC <sup>1</sup>	---
	¾	BPF56	2741012C	25
¾	½	BPF64	2741208C	25
	¾	BPF66	2741212C	25
	¾	---	2741212CBC <sup>1</sup>	---
1	¾	BPF86	2741612C	10
	1	BPF88	2741616C	10



brass cap

<sup>1</sup> Brass cap on CBC parts

## Push-On Hose Barb Fittings



- Intended for use with Lok-On (push-on style) hose only
- No hose clamps or ferrules are needed for installation
- Properly grips push-on hose only when pushed all the way in, with the cut end of the hose completely concealed by the plastic cap.

B



brass cap

### Female NPSM Swivel x Hose Barb Ball Seat

Hose ID (inch)	Female NPSM (inch)	Brass		Pkg Qty
		Previous Part No.	Part No.	
¼	¼	BPFS21	2780402C	100
	¼	---	2780402CBC <sup>1</sup>	100
	¼	BPFS22	2780404C	50
	¼	---	2780404CBC <sup>1</sup>	50
	¾	BPFS23	2780406C	50
¾	¾	---	2780406CBC <sup>1</sup>	50
	¼	BPFS32	2780604C	50
	¼	---	2780604CBC <sup>1</sup>	50
	¾	BPFS33	2780606C	50
¾	¾	---	2780606CBC <sup>1</sup>	50
	½	BPFS34	2780608C	25
	½	BPFS44	2780808C	50
	½	---	2780808CBC <sup>1</sup>	50
½	¾	BPFS46	2780812C	25
	¾	---	2780812CBC <sup>1</sup>	20
	¾	BPFS56	2781012C	20
¾	¾	BPFS66	2781212C	20
¾	¾	---	2781212CBC <sup>1</sup>	---

<sup>1</sup> Brass cap on CBC parts

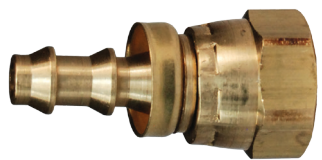

brass cap

### Female NPSM Swivel x Hose Barb Gasket Seat

Hose ID (inch)	Female NPSM (inch)	Brass		Pkg Qty
		Previous Part No.	Part No.	
¼	¼	280-0402	2800402C	100
	¼	---	2800402CBC <sup>1</sup>	100
	¼	280-0404	2800404C	100
	¼	---	2800404CBC <sup>1</sup>	100
¾	¼	280-0604	2800604C	50
	¼	---	2800604CBC <sup>1</sup>	50
	¾	280-0606	2800606C	50
	¾	---	2800606CBC <sup>1</sup>	50
	½	280-0608	2800608C	50
½	½	---	2800608CBC <sup>1</sup>	50
	½	280-0808	2800808C	25
	½	---	2800808CBC <sup>1</sup>	25
¾	½	280-1008	2801008C	25
¾	¾	280-1212	2801212C	20
	¾	---	2801212CBC <sup>1</sup>	20

<sup>1</sup> Brass cap on CBC parts

- Not recommended for use with water



brass cap

### Hose Menders

Hose ID (inch)	Brass		303 Stainless Steel		Pkg Qty
	Previous Part No.	Part No.	Previous Part No.	Part No.	
¼	BPM2	2960404C	SSPM2	2960404SS	100
	---	2960404CBC <sup>1</sup>	---	---	100
5/16	BPM25	2960505C	---	---	100
¾	BPM3	2960606C	SSPM3	2960606SS	50
	---	2960606CBC <sup>1</sup>	---	---	50
½	BPM4	2960808C	SSPM4	2960808SS	50
	---	2960808CBC <sup>1</sup>	---	---	50
¾	BPM5	2961010C	SSPM5	---	20
	---	2961010CBC <sup>1</sup>	---	---	20
¾	BPM6	2961212C	SSPM6	---	15
	---	2961212CBC <sup>1</sup>	---	---	15
1	BPM8	2961616C	---	---	10

<sup>1</sup> Brass cap on CBC parts

# Industrial Hose Fittings

## Reusable Fittings

<b>Application:</b>	<ul style="list-style-type: none"> <li>Recommended for low-pressure air hose applications</li> </ul>
<b>Features:</b>	<ul style="list-style-type: none"> <li>Maximum working pressure: <b>250 PSI</b> at ambient temperature <b>21°C (70°F)</b></li> <li>Durable, easily repaired hose connection</li> </ul>

 **Caution: check hose OD and ID accurately before ordering**

Male Thread					
Hose ID (inch)	Hose OD (inch)	Male NPTF (inch)	Brass		Pkg Qty
			Previous Part No.	Part No.	
1/4	1/2	1/8	BN21RU50	1834082K	100
	9/16	1/8	BN21RU56	1834092K	100
	5/8	1/8	BN21RU62	1834102K	100
	1/2	1/4	BN22RU50	1834084K	50
	9/16	1/4	BN22RU56	1834094K	50
	5/8	1/4	BN22RU62	1834104K	50
	1/2	3/8	BN23RU50	1834086K	50
	9/16	3/8	BN23RU56	1834096K	50
5/16	5/8	3/8	BN23RU62	1834106K	50
	9/16	1/4	BN252RU56	1835094K	50
	5/8	1/4	BN252RU62	1835104K	50
	11/16	1/4	BN252RU68	1835114K	50
	9/16	3/8	BN253RU56	1835096K	50
	5/8	3/8	BN253RU62	1835106K	50
3/8	11/16	3/8	BN253RU68	1835116K	50
	5/8	1/4	BN32RU62	1836104K	50
	11/16	1/4	BN32RU68	1836114K	50
	3/4	1/4	BN32RU75	1836124K	50
	5/8	3/8	BN33RU62	1836106K	50
	11/16	3/8	BN33RU68	1836116K	50
	3/4	3/8	BN33RU75	1836126K	50
	5/8	1/2	BN34RU62	1836108K	50
	11/16	1/2	BN34RU68	1836118K	50
	3/4	1/2	BN34RU75	1836128K	50
1/2	7/8	1/4	BN42RU87	1838144K	25
	15/16	1/4	BN42RU93	1838154K	25
	1	1/4	BN42RU99	1838164K	25
	7/8	3/8	BN43RU87	1838146K	25
	15/16	3/8	BN43RU93	1838156K	25
	1	3/8	BN43RU99	1838166K	25
	7/8	1/2	BN44RU87	1838148K	20
	15/16	1/2	BN44RU93	1838158K	20
1	1/2	BN44RU99	1838168K	20	



Male Thread					
Hose ID (inch)	Hose OD (inch)	Male NPT (inch)	303 Stainless Steel		Pkg Qty
			Previous Part No.	Part No.	
1/4	1/2	1/8	BN21RU50SS	1834082KSS	100
	9/16	1/8	BN21RU56SS	1834092KSS	100
	5/8	1/8	BN21RU62SS	1834102KSS	100
	1/2	1/4	BN22RU50SS	1834084KSS	50
	9/16	1/4	BN22RU56SS	1834094KSS	50
	5/8	1/4	BN22RU62SS	1834104KSS	50
5/16	9/16	1/4	BN252RU56SS	1835094KSS	50
	5/8	1/4	BN252RU62SS	1835104KSS	50
3/8	5/8	1/4	BN32RU62SS	1836104KSS	50
	11/16	1/4	BN32RU68SS	1836114KSS	50
	3/4	1/4	BN32RU75SS	1836124KSS	50
	5/8	3/8	BN33RU62SS	1836106KSS	50
	11/16	3/8	BN33RU68SS	1836116KSS	50
	3/4	3/8	BN33RU75SS	1836126KSS	50
	7/8	3/8	BN43RU87SS	1838146KSS	25
	15/16	3/8	BN43RU93SS	1838156KSS	25
	7/8	1/2	BN44RU87SS	1838148KSS	20
	15/16	1/2	BN44RU93SS	1838158KSS	20



B

# Industrial Hose Fittings

## Reusable Fittings

B

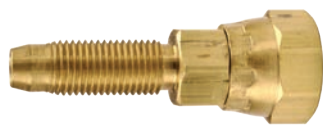

Swivel Stems				
Hose ID (inch)	Female NPSM (inch)	Brass Part No.		Optional Qty
1/4	1/4-18	1840404A		50
	3/8-18	1840406A		50
5/16	1/4-18	1840504A		50
3/8	1/4-18	1840604A		50
	3/8-18	1840606A		50
1/2	1/2-14	1840808A		25



Female Swivels					
Hose ID (inch)	Hose OD (inch)	Female NPSM (inch)	Brass		
			Previous Part No.	Part No.	Optional Qty
1/4	1/2	1/4	185-4084	1854084K	50
	9/16	1/4	185-4094	1854094K	50
	5/8	1/4	185-4104	1854104K	50
	1/2	3/8	185-4086	1854086K	50
	9/16	3/8	185-4096	1854096K	50
	5/8	3/8	185-4106	1854106K	50
5/16	9/16	1/4	185-5094	1855094K	50
	5/8	1/4	185-5104	1855104K	50
	11/16	1/4	185-5114	1855114K	50
3/8	5/8	1/4	185-6104	1856104K	50
	11/16	1/4	185-6114	1856114K	50
	3/4	1/4	185-6124	1856124K	50
	5/8	3/8	185-6106	1856106K	50
	11/16	3/8	185-6116	1856116K	50
	3/4	3/8	185-6126	1856126K	50
1/2	7/8	1/2	185-8148	1858148K	20
	15/16	1/2	185-8158	1858158K	20
	1	1/2	185-8168	1858168K	20



Splicer Stems		
Hose ID (inch)	Brass Part No.	Optional Qty
1/4	1860404S	100
3/8	1860606S	50



Hose Splicers				
Hose ID (inch)	Hose OD (inch)	Brass		
		Previous Part No.	Part No.	Optional Qty
1/4	1/2	187-0408	1870408K	50
	9/16	187-0409	1870409K	50
	5/8	187-0410	1870410K	50
3/8	5/8	187-0610	1870610K	25
	11/16	187-0611	1870611K	25
	3/4	187-0612	1870612K	25



## Reusable Fittings

Ferrules				
Hose ID (inch)	Hose OD (inch)	Brass Part No.	303 Stainless Steel Part No.	Optional Qty
¼	½	1800408F	1800408FSS	100
	9/16	1800409F	1800409FSS	50
	5/8	1800410F	1800410FSS	50
5/16	9/16	1800509F	1800509FSS	100
	5/8	1800510F	1800510FSS	50
	11/16	1800511F	---	50
¾	5/8	1800610F	1800610FSS	50
	11/16	1800611F	1800611FSS	50
	¾	1800612F	1800612FSS	50
½	7/8	1800814F	1800814FSS	25
	15/16	1800815F	1800815FSS	25
	1	1800816F	---	20

Male Stems				
Hose ID (inch)	Male NPTF <sup>1</sup> (inch)	Brass Part No.	303 Stainless Steel <sup>1</sup> Part No.	Optional Qty
¼	⅛	1820402S	1820402SS	100
	¼	1820404S	1820404SS	100
	⅜	1820406S	---	50
5/16	¼	1820504S	1820504SS	50
	⅜	1820506S	---	50
¾	¼	1820604S	1820604SS	100
	⅜	1820606S	1820606SS	50
	½	1820608S	---	25
½	¼	1820804S	---	50
	⅜	1820806S	1820806SS	50
	½	1820808S	1820808SS	25

<sup>1</sup> Stainless steel parts have NPT threads

## Long Shank Fittings

**Features:** • Extended male GHT, deeper thread

Complete Couplings - GHT				
Hose ID (inch)	GHT (inch)	Plated Steel Part No.	Brass	
			Previous Part No.	Part No.
⅜	¾	SLS307	---	---
½	¾	SLS407	BLS407	5950808K
5/8	¾	SLS507	BLS507	5951010K
¾	¾	SLS607	BLS607	5951212K

Female Couplings - GHT						
Hose ID (inch)	GHT (inch)	Plated Steel Part No.	Brass			Lead-Free Brass Part No.
			Previous Part No.	Part No.	Pkg Qty	
⅜	¾	SLS347	---	---	---	---
½	¾	SLS447	BLS447	5940812C	25	---
5/8	¾	SLS547	BLS547	5941012C	25	---
¾	¾	SLS647	BLS647	5941212C	25	5941212CLF <sup>1</sup>

**Features:** • Extended male GHT, deeper thread

Male Couplings - GHT						
Hose ID (inch)	GHT (inch)	Plated Steel Part No.	Brass			Lead-Free Brass Part No.
			Previous Part No.	Part No.	Pkg Qty	
⅜	¾	SLS317	---	---	50	---
½	¾	SLS417	BLS417	5930812C	25	---
5/8	¾	SLS517	BLS517	5931012C	25	---
¾	¾	SLS617	BLS617	5931212C	10	5931212CLF <sup>1</sup>

<sup>1</sup> Lead-free brass <=0.25% lead; Alloy CA2745; Alloy C46400

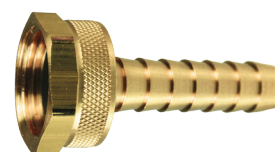
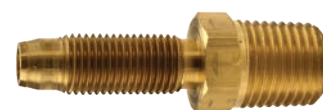

B

## Dixon™ Frac Fittings

B

<b>Application:</b>	<ul style="list-style-type: none"> <li>Used in the fast-paced transfer of water and sand slurry to a hydraulic fracturing site</li> </ul>
<b>Features:</b>	<ul style="list-style-type: none"> <li>One-piece design eliminates leak path experienced with two-piece threaded systems</li> <li>Interchangeable with current fittings; phase them into your current operation</li> <li>Long-lasting and dependable hammer nut is forged to ASTM 105N standards</li> <li>Machined malleable iron stems to ASTM A47 standard</li> <li>Durable and safe with reliable hose retention when crimped as specified</li> <li><b>400 PSI</b> working pressure at <b>21°C (70°F)</b></li> <li><b>400 PSI</b> working pressure with a minimum 4:1 safety factor (hose burst: hose working pressure) is only achieved with Dixon™ carbon steel ferrule part numbers CF400-6CSDH through CF400-16CSDH, refer to page 74</li> <li>When assembling hose with abrasion covers, such as UHMW polyethylene, you will need to use Dixon™'s heavy duty (HD) carbon steel ferrule part numbers CF400-6CSDH through CF400-16CSDH, refer to page 74</li> </ul>
<b>Material:</b>	<ul style="list-style-type: none"> <li>All stems are zinc plated</li> </ul>



4"



3" and 4"



8"



HUM206300CS &amp; HUM206400CS



HUM206600CS &amp; HUM206800CS

### Complete Male / Female Assembly

Size (inch)	Figure	Part No.
2	206	HUMF206200CS
3	100	HUMF100300CS
	206	HUMF206300CS
4	100	HUMF100400CS
	206	HUMF206400CS
6	100	HUMF100600CS
	206	HUMF206600CS
8	100 <sup>1</sup>	HUMF100800CS <sup>1</sup>
	206	HUMF206800CS <sup>1</sup>

### Female

Size (inch)	Figure	Part No.
2	206	HUF206200CS
3	100	HUF100300CS
	206	HUF206300CS
4	100	HUF100400CS
	206	HUF206400CS
6	100	HUF100600CS
	206	HUF206600CS
8	100 <sup>1</sup>	HUF100800CS <sup>1</sup>
	206	HUF206800CS <sup>1</sup>

### Male with Nut

Size (inch)	Figure	Part No.
2	206	HUM206200CS <sup>1</sup>
3	100	HUM100300CS
	206	HUM206300CS <sup>1</sup>
4	100	HUM100400CS
	206	HUM206400CS <sup>1</sup>
6	100	HUM100600CS
	206	HUM206600CS <sup>1</sup>
8	100	HUM100800CS
	206	HUM206800CS <sup>1</sup>

<sup>1</sup> Meets both figure 100 and 206 dimensional specifications

## Dixon™ Frac Fittings

<b>Application:</b>	<ul style="list-style-type: none"> <li>Used in the fast-paced transfer of water and sand slurry to a hydraulic fracturing site</li> </ul>
<b>Features:</b>	<ul style="list-style-type: none"> <li>One-piece design eliminates leak path experienced with two-piece threaded systems</li> <li>Interchangeable with current fittings; phase them into your current operation</li> <li>Long-lasting and dependable hammer nut is forged to ASTM 105N standards</li> <li>Machined malleable iron stems to ASTM A47 standard</li> <li>Durable and safe with reliable hose retention when crimped as specified</li> <li><b>400 PSI</b> working pressure at <b>21°C</b></li> <li><b>400 PSI</b> working pressure with a minimum 4:1 safety factor (hose burst: hose working pressure) is only achieved with Dixon™ carbon steel ferrule part numbers CF400-6CSHD through CF400-16CSHD, refer to page 74</li> <li>When assembling hose with abrasion covers, such as UHMW polyethylene, you will need to use Dixon™'s heavy duty (HD) carbon steel ferrule part numbers CF400-6CSHD through CF400-16CSHD, refer to page 74</li> </ul>
<b>Material:</b>	<ul style="list-style-type: none"> <li>All stems are zinc plated</li> </ul>



## Suction Service Fittings

Figure 206			
Size (inch)	Figure	Description	Part No.
5	50	Socket weld x suction male hammer union (includes o-ring, no nut)	HUSM500SW-1
	50	Socket weld x suction female hammer union	HUSF500SW
	N/A	Split nut, suction and discharge, black	HUS500RN



HUSM500SW-1



HUSF500SW

## Dixon™ Figure 206 O-rings

Figure 206			
Size (inch)	Material	Description	Part No.
2	Buna-N	Figure 206 O-ring	O288BU
3		Figure 206 O-ring	O238BU
4		Figure 206 O-ring	O347BU
4		Figure 206 Cap O-ring	O429BU
6		Figure 206 O-ring	O440BU
8		Figure 206 O-ring	O447BU

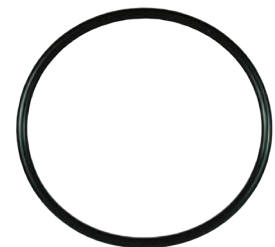

## King Crimp™ Style Short Frac Ferrules

Carbon Steel						
Hose ID (inch)	Hose OD (inch)		Ferrule Wall Thickness (inch)	Ferrule ID (inch)	Ferrule Overall Length (inch)	Part No.
	From	To				
8	8-29/64	8-36/64	.120	8.625	4.25	CFS800-1CS
	8-37/64	8-44/64	.120	8.750	4.25	CFS800-2CS
	8-45/64	8-52/64	.120	8.875	4.25	CFS800-3CS
	8-53/64	8-60/64	.120	9.000	4.25	CFS800-4CS
	8-61/64	9-4/64	.120	9.125	4.25	CFS800-5CS
	9-5/64	9-12/64	.120	9.250	4.25	CFS800-6CS
	9-13/64	9-20/64	.120	9.375	4.25	CFS800-7CS
	9-21/64	9-28/64	.120	9.500	4.25	CFS800-8CS



# Industrial Hose Fittings

## King Crimp™ Style Heavy Duty Ferrules

**Feature:**

- 400 PSI working pressure with a minimum 4:1 safety factor (hose burst: hose working pressure) is only achieved with heavy duty (HD) crimp ferrules, CF400-6CSHD through CF400-16CSHD

Hose ID (inch)	Hose OD (mm)		Ferrule ID (inch)	Ferrule Wall Thickness (mm)	Ferrule Overall Length (mm)	Carbon Steel
	From	To				Heavy Duty (HD) Part No.
4	114.70	115.90	4.625	3.05	102	CF400-6CSHD
	116.30	117.50	4.688	3.05	102	CF400-7CSHD
	117.90	119.10	4.750	3.05	102	CF400-8CSHD
	119.45	120.65	4.813	3.05	102	CF400-9CSHD
	121.00	122.25	4.875	3.05	102	CF400-10CSHD
	122.60	123.80	4.938	3.05	102	CF400-11CSHD
	124.20	125.40	5.000	3.05	102	CF400-12CSHD
	125.80	127.00	5.063	3.05	102	CF400-13CSHD
	127.40	128.60	5.125	3.05	102	CF400-14CSHD
	129.00	130.20	5.188	3.05	102	CF400-15CSHD
130.60	131.80	5.250	3.05	102	CF400-16CSHD	



Only use the crimp style shanks with the crimp style sleeves and ferrules. Due to differences in dimensions and tolerances for safety reasons, do not interchange other manufacturers' products with Dixon™ products.

## King Crimp™ Style Sleeves

**Option:**

- Consult Dixon™ for additional sleeve sizes

Hose ID (inch)	Sleeve ID (inch)	Sleeve Wall Thickness (mm)	Sleeve Overall Length (mm)	Carbon Steel
				Part No.
8	8.30	3.05	222	S830X875X120CS
	8.38	3.05	152	S838X600X120CS
	8.50	3.05	165	S850X650X120CS
	8.75	3.05	152	S875X600X120CS
	8.98	3.05	222	S898X875X120CS
	9.00	3.05	102	S900X400X090CS
	9.00	3.05	102	S900X400X120CS
	9.00	3.05	152	S900X600X120CS
	9.10	3.05	102	S910X400X120CS
	9.12	3.05	152	S912X600X120CS
	9.15	3.05	152	S915X600X120CS
	9.25	3.05	152	S925X600X120CS
	9.25	3.05	102	S925X400X120CS
	9.50	3.05	102	S950X400X120CS
	9.50	3.05	152	S950X600X120CS
9.75	3.05	152	S975X600X120CS	
10	10.25	3.05	191	S1025X750X120CS
	10.50	3.05	191	S1050X750X120CS
	11.00	3.05	152	S1100X600X120CS
	11.75	3.05	152	S1175X600X120CS

## Dixon™ One-Piece Hammer Union Nuts

<b>Features:</b>	<ul style="list-style-type: none"> <li>• Long-lasting and dependable nut</li> <li>• All nuts are interchangeable with reliable brands</li> <li>• Cold working pressure: <b>2,000 PSI</b></li> <li>• 6" and 8" sizes have 4-lug design for more surface area to hammer</li> </ul>
<b>Material:</b>	<ul style="list-style-type: none"> <li>• Forged steel meeting AISI standards</li> </ul>

Forged Steel		
Size (inch)	Description	Part No.
3	Wing nut, figure 100	HU100300N
3	Wing nut, figure 206	HU206300N
4	Wing nut, figure 100	HU100400N
4	Wing nut, figure 206	HU206400N
6	Wing nut, figure 100	HU100600N
6	Wing nut, figure 206	HU206600N
8	Wing nut, figure 100	HU100800N
8	Wing nut, figure 206	HU206800N



3" and 4"



6" and 8"



## Dixon™ Two-Piece Hammer Union Nuts

<b>Application:</b>	<ul style="list-style-type: none"> <li>• Replacement for damaged hammer union nuts</li> <li>• Used with male one-piece flange adaptors</li> </ul>
<b>Features:</b>	<ul style="list-style-type: none"> <li>• Lug design provides enlarged surface area to hammer</li> <li>• Repair nut is pinned and bolted for perfect alignment</li> <li>• Nut can be installed on pre-existing hammer union assembly</li> <li>• Cold working pressure: <b>2,000 PSI</b></li> <li>• 4" figure 200/206 nut is interchangeable with reliable brands</li> <li>• 6" and 8" figure 100/200/206 nuts are interchangeable with reliable brands</li> <li>• Available in other series and sizes, contact Dixon™</li> </ul>
<b>Material:</b>	<ul style="list-style-type: none"> <li>• Forged steel meeting AISI standards</li> </ul>

Forged Steel		
Size (inch)	Description	Part No.
4	Split nut, figure 200/206, blue (includes bolts)	HU200400RN
5	Split nut, suction and discharge, black	HUS500RN
6	Split nut, figure 100, black (includes bolts)	HU100600RN
6	Split nut, figure 200/206, blue (includes bolts)	HU200600RN
8	Split nut, figure 100, black (includes bolts)	HU100800RN
8	Split nut, figure 200/206, blue (includes bolts)	HU200800RN



figure 200 / 206



suction and discharge

 Dixon™ recommends using Loctite® Threadlocker Red 271™ when bolting together two-piece hammer union nuts to ensure that bolts do not loosen when in service. Option two is to weld the seams of the split nut. Bolt torque recommendation is 60 foot pounds.

## Dixon™ One-Piece Flange Adaptors



male adaptor x flange  
with hammer union nut



female adaptor x flange



male adaptor x 45° flange  
with hammer union nut

<b>Applications:</b>	<ul style="list-style-type: none"> <li>Used in the transfer of water, brine, water-based chemicals, water-based acids, and gelatinous proppant (sand) slurry used at hydraulic fracturing sites</li> <li>Used with HU200400RN two-piece nut</li> </ul>
<b>Features:</b>	<ul style="list-style-type: none"> <li>Flange x female or male hammer union straights (standard or short length)</li> <li>45° elbows in female and male (flange x hammer union)</li> <li>No welds or pipe threads to deteriorate and cause premature leakage</li> <li>Two-piece nut is pinned and bolted for perfect alignment</li> <li>All 4" figure 206 threads are interchangeable with other reliable brands</li> <li>All 4" 150# flanges are compatible with other reliable brands</li> </ul>
<b>Materials:</b>	<ul style="list-style-type: none"> <li>Iron adaptors meet ASTM standards</li> <li>Forged steel nuts meet AISI standards</li> </ul>

Figure 206

Size (inch)	Overall Length (mm)	Description	Part No.
4	131.2	Female hammer union x 150# flange	HUF206400FLG
	76	Female hammer union x 150# flange short	HUF206400FLG-ST
	279	Female hammer union x 150# flange 45° elbow	HUF206400FLG-45
	131 (with nut)	Male hammer union x 150# flange includes nut and buna-n o-ring	HUM206400FLG
	87 (with nut)	Male hammer union x 150# short flange includes nut and buna-n o-ring	HUM206400FLG-ST
	306 (with nut)	Male hammer union x 150# flange 45° elbow includes nut and buna-n o-ring	HUM206400FLG-45
	---	O-ring (buna-n)	O347BU

## Hammer Union Caps and Plugs



cap



plug

<b>Applications:</b>	<ul style="list-style-type: none"> <li>Prevents leakage of hydraulic fracturing fluids from hammer union connections.</li> <li>Used in pressurized service on site or when transferring equipment.</li> </ul>
<b>Features:</b>	<ul style="list-style-type: none"> <li>Forged steel construction ensures longevity, reliability, and performance</li> <li>Designed with larger handle for easier installation and disassembling</li> <li>Design includes a handle hole to attach chain or cable</li> </ul>
<b>Material:</b>	<ul style="list-style-type: none"> <li>Forged steel meeting AISI standards</li> </ul>

Figure 206

Size (inch)	Description	Part No.
4	Hammer union cap	HUC207400
	Hammer union plug	HUP207400

## Hookie - Hook Hose Lifter



<b>Features:</b>	<ul style="list-style-type: none"> <li>For use with hammer unions</li> <li>Safe working load is 4 tons, with a proof load test of 8 tons</li> <li>Supplied complete with retaining clamp</li> </ul>
------------------	---

Forged Carbon Steel

Size (inch)	Part No.
3	HA0900-3
4	HA0900-4
5	HA0900-5

## Hammer Unions

<b>Features:</b>	<ul style="list-style-type: none"> <li>• Butt weld configurations and other materials are available, contact Dixon™ for further information</li> <li>• Temperature rating: <b>-32°C to 93°C (25°F to 199°F)</b></li> <li>• Non-shocking cold water pressure means that the rated value is the maximum pressure at ambient temperature <b>21°C (70°F)</b>:                         <ul style="list-style-type: none"> <li>• No spikes higher than this pressure</li> <li>• No instantaneous pressure increases (<b>0-2000 PSIG</b> in ¼ of a second)</li> </ul> </li> </ul>
------------------	--

Hammer unions work at extremely high pressures. Mismatching components of one series with another (i.e. series 602 with series 1502) can lead to destruction of property, serious bodily injury or death.

<b>Application:</b>	<ul style="list-style-type: none"> <li>• Used on low-pressure manifolds and lines and in applications running air, water, oil, or gas up to <b>1000 PSI</b> NSCWP (non-shock cold working pressure)</li> </ul>
<b>Feature:</b>	<ul style="list-style-type: none"> <li>• Butt weld ends are schedule 80</li> </ul>
<b>Colour:</b>	<ul style="list-style-type: none"> <li>• Yellow sub, black nut</li> </ul>

100 Series			
Size (inch)	Configuration	NSCWP	Forged Steel
			Part No.
2	FNPT Threaded	1000	HU100200
2	Welded	1000	HU100200BW
2½	FNPT Threaded	1000	HU100250
3	FNPT Threaded	1000	HU100300
4	FNPT Threaded	1000	HU100400
4	Welded	1000	HU100400BW
6	FNPT Threaded	1000	HU100600
8	FNPT Threaded	1000	HU100800



<b>Application:</b>	<ul style="list-style-type: none"> <li>• Used in general service applications running air, water, oil, or gas up to <b>2000 PSI</b> NSCWP (non-shock cold working pressure)</li> </ul>
<b>Feature:</b>	<ul style="list-style-type: none"> <li>• Butt weld ends are schedule 80</li> </ul>
<b>Colour:</b>	<ul style="list-style-type: none"> <li>• Grey sub, blue nut</li> </ul>

200 Series			
Size (inch)	Configuration	NSCWP	Forged Steel
			Part No.
1	FNPT Threaded	2000	HU200100
1½	FNPT Threaded	2000	HU200150
2	FNPT Threaded	2000	HU200200
2	Welded	2000	HU200200BW
2½	FNPT Threaded	2000	HU200250
3	FNPT Threaded	2000	HU200300
4	FNPT Threaded	2000	HU200400
6	FNPT Threaded	2000	HU200600
8	FNPT Threaded	2000	HU200800



<b>Application:</b>	<ul style="list-style-type: none"> <li>• Runs air, water, oil or gas up to <b>2000 PSI</b> NSCWP (non-shock cold working pressure)</li> </ul>
<b>Design:</b>	<ul style="list-style-type: none"> <li>• O-ring mounted sub provides excellent sealing properties</li> </ul>
<b>Colour:</b>	<ul style="list-style-type: none"> <li>• Grey sub, blue nut</li> </ul>

206 Series			
Size (inch)	Configuration	NSCWP	Forged Steel
			Part No.
1	FNPT Threaded	2000	HU206100
1½	FNPT Threaded	2000	HU206150
2	FNPT Threaded	2000	HU206200
2½	FNPT Threaded	2000	HU206250
3	FNPT Threaded	2000	HU206300
4	FNPT Threaded	2000	HU206400
6	FNPT Threaded	2000	HU206600
8	FNPT Threaded	2000	HU206800



B

## Hammer Unions (continued)

B



### Features:

- Butt weld configurations and other materials are available, contact Dixon™ for further information
- Temperature rating: **-32°C to 93°C (25°F to 199°F)**
- Non-shocking cold water pressure means that the rated value is the maximum pressure at ambient temperature **21°C (70°F)**:
  - No spikes higher than this pressure
  - No instantaneous pressure increases (**0-2000 PSIG** in ¼ of a second)



Hammer unions work at extremely high pressures. Mismatching components of one series with another (ie series 602 with series 1502) can lead to destruction of property, serious bodily injury or death.

### Application:

- Used on manifold and line connections, pump, suction and mud service. Up to **4000 PSI** NSCWP (non-shock cold working pressure)

### Colour:

- Red sub, black nut

### 400 Series

Size (inch)	Configuration	NSCWP	Forged Steel
			Part No.
2	FNPT Threaded	4000	HU400200
3	FNPT Threaded	4000	HU400300
4	FNPT Threaded	4000	HU400400

### Application:

- For use in mud, manifold service, and truck mounting applications running air, water, oil, gas, or mud up to **6000 PSI** NSCWP (non-shock cold working pressure)

### Design:

- Lip type seal ring minimises fluid flow turbulence while creating a pressure seal

### Colour:

- Orange sub, black nut

### 602 Series

Size (inch)	Configuration	NSCWP	Forged Steel
			Part No.
1	FNPT Threaded	6000	HU602100
2	FNPT Threaded	6000	HU602200
2	Buttweld	6000	HU602200BW
3	FNPT Threaded	6000	HU602300
3	Buttweld	6000	HU602300BW
4	FNPT Threaded	6000	HU602400
4	Buttweld	6000	HU602400BW

### Application:

- For use in high-pressure systems and truck mounting applications running air, water, oil, gas, or mud up to **10000 PSI** NSCWP (non-shock cold working pressure)

### Design:

- Lip type seal ring minimises fluid flow turbulence while creating a pressure seal

### Colour:

- Blue sub, red nut

### 1002 Series

Size (inch)	Configuration	NSCWP	Forged Steel
			Part No.
1	FNPT Threaded	10000	HU1002100
2	FNPT Threaded	10000	HU1002200
2	Buttweld	10000	HU1002200BW
3	FNPT Threaded	10000	HU1002300
3	Buttweld	10000	HU1002300BW
4	FNPT Threaded	10000	HU1002400
4	Buttweld	10000	HU1002400BW

### Application:

- For use in extreme high-pressure applications running air, water, oil, gas, or mud up to **15000 PSI** NSCWP (non-shock cold working pressure)

### Design:

- Lip type seal ring minimises fluid flow turbulence while creating a pressure seal

### Colour:

- Red sub, blue nut

### 1502 Series

Size (inch)	Configuration	NSCWP	Forged Steel
			Part No.
1	FNPT Threaded	15000	HU1502100
2	FNPT Threaded	15000	HU1502200
2	Buttweld	15000	HU1502200BW
3	FNPT Threaded	15000	HU1502300
3	Buttweld	15000	HU1502300BW
4	FNPT Threaded	15000	HU1502400
4	Buttweld	15000	HU1502400BW



## Swivel Joints

<b>Applications:</b>	<ul style="list-style-type: none"> <li>Used wherever a leak-proof swivel connection is needed in pipelines or in combination with hoses to eliminate hose twisting</li> <li>Industries range from petroleum, petrochemical, refining, mining, distilling, paint, farm irrigation and fertilizing, wastewater treatment plants, and food and beverage process equipment. Dixon™'s swivel joints are found in blending plants, drum filling applications, fluid and dry bulk transfer, vacuum trucks, oil and gas trucks, and water trucks. Larger swivels can be found in the steel industry, marine bulk transfer, and more.</li> </ul>
<b>Features:</b>	<ul style="list-style-type: none"> <li>Full 360° rotational movement</li> <li>Wide spacing between dual ball bearing raceways ensures greater load-bearing capacity</li> <li>Precision-machined design ensures alignment and years of trouble-free service</li> <li>O-ring dust seal protects the ball races and seals chamber from outside elements</li> <li>Radius elbow design ensures a smooth flow pattern</li> <li>Hydrostatic testing is performed on all swivels before shipment</li> </ul>
<b>Options Available:</b>	<ul style="list-style-type: none"> <li>End configurations: female NPT, 150# flanges, TTMA flange, grooved, weld end, and many other variations</li> <li>Seal options: Buna, FKM, PTFE, EPDM, FDA Buna, FFKM</li> <li>Ball bearing materials: carbon steel, 440 stainless steel, and 316 stainless steel</li> <li>Grease materials: Lithium, FDA approved/food grade and silicone</li> <li>Swivels that include oxygen, steam or submerged service can be specifically designed for unique applications (special order)</li> <li>100% full penetration weld</li> <li>Re-build kits available</li> <li>Custom swivel options available, contact Dixon™ on +44 (0)1772 323529</li> </ul>



## O-ring Swivel Joints - Parts Identification List

- O-ring (dust) seal
- Ball retainer screw
- O-ring (pressure) seal
- Grease fitting
- Ball bearings

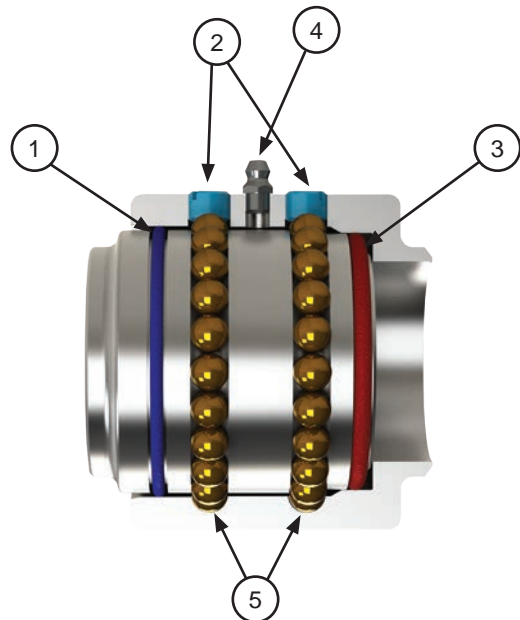

### O-ring Features:

- Sizes: 1"-4"
- O-ring pressure seal ensures a leak-proof seal and smooth rotation with lower torque.
- Available working pressure ratings up to **1000 PSI** (6900 kPa)
- Available in carbon steel, 316L stainless steel, aluminium, brass, and malleable iron

## V-ring Swivel Joints - Parts Identification List

- Body
- Sleeve
- Ball bearings
- Seal retainer
- V-ring (pressure) seal
- Spring retainer
- Ball retainer screw
- Grease fitting
- O-ring (dust) seal

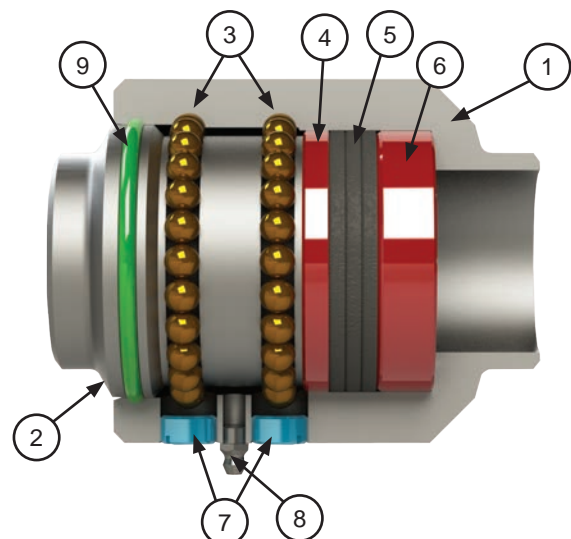

### V-Ring Features:

- Sizes: 2"-12"
- Spring loaded triple V-ring sealing system ensures a leak-proof seal at either high or low-pressure, and extends seal life
- Available working pressure ratings up to **1000 PSI** (6900 kPa)
- Available in carbon steel, 316L stainless steel, and limited aluminium

## Swivel Joints Style Planes of Rotation - Single Plane Style 20

B



female NPT x female NPT



150# ASA flange x 150# ASA flange

## Single Plane Style 30



female NPT x female NPT



150# ASA flange x 150# ASA flange

## Single Plane Style 40



female NPT x female NPT



150# ASA flange x 150# ASA flange

## Single Plane Style 50



female NPT x female NPT



150# ASA flange x 150# ASA flange

B

## Double Plane Style 60



female NPT x female NPT



150# ASA flange x 150# ASA flange

## Double Plane Style 70



female NPT x female NPT



150# ASA flange x 150# ASA flange

## Swivel Joints Style Planes of Rotation - Triple Plane Style 80



female NPT x female NPT



150# ASA flange x 150# ASA flange

## Triple Plane Style 10

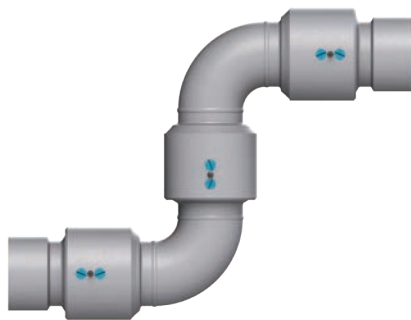

female NPT x female NPT

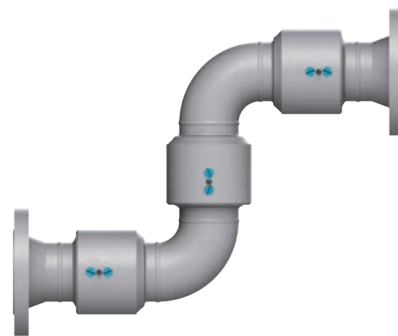

150# ASA flange x 150# ASA flange

## Working Pressures

Dixon™ swivels are recommended for use at the following maximum Non-Shock Cold Working Pressures (NSCWP) provided in PSI, at ambient temperature 21°C (70°F).

Size	V-ring Carbon Steel CS	O-ring Carbon Steel OC	V-ring Stainless Steel SS	O-ring Stainless Steel OS	Aluminium AL	Brass BR	Malleable Iron MI
1"	---	1000	---	1000	150	---	---
1¼"	---	---	---	---	150	---	---
1½"	---	1000	---	1000	150	300	600
2"	1000	1000	1000	1000	150	300	600
3"	1000	1000	1000	1000	150	300	600
4"	1000	---	1000	---	150	---	---
6"	1000	---	---	---	150	---	---
8"	---	---	---	---	150	---	---

- When using flanged ends, the pressure rating will be reduced to coincide with that of the flange being used. Carbon steel and stainless steel 150# flanges are recommended for use at **275 maximum PSI** at ambient temperature 21°C (70°F).
- Lubrication should be performed periodically, depending on service and operating conditions. Twice yearly is normally sufficient.
- All dimensions are approximate. Where critical, contact Dixon™ on +44 (0)1772 323529.

## Ordering Information - Swivels

Size	
Style (Shape)	
End Configuration	
Material	
Maximum Working Pressure	
Temperature Range	
Media: specify product being handled (if chemical, advise concentration)	
Submerged or Oxygen Service	
If for constant rotation, advise RPM	
If for suction service, advise maximum vacuum in inches of mercury (Hg)	



Our sales and engineering staff will be happy to help you evaluate your swivel application. Please call +44 (0)1772 323529.

## Ordering Information • Swivels

Example:  $\frac{2}{[A]}$   $\frac{20}{[B]}$   $\frac{F}{[C]}$  X  $\frac{F}{[C]}$   $\frac{CS}{[D]}$   $\frac{0}{[E]}$   $\frac{0}{[F]}$   $\frac{1}{[G]}$   $\frac{0}{[H]}$   $\frac{0}{[I]}$

<b>A</b> Size					
<b>B</b> Style					
<b>C</b> End Connections	<b>W</b> Weld End	<b>F</b> Female NPT	<b>FG</b> 150# ASA Flange	<b>TF</b> Tank Truck Flange	<b>PF</b> 300# ASA Flange (not available in aluminium)
<b>D</b> Material	<b>CS (V-ring)</b> Carbon Steel OC (O-ring) Carbon Steel	<b>SS (V-ring)</b> Stainless Steel OS (O-ring) Stainless Steel	<b>AL</b> Aluminium	<b>BR</b> Brass	<b>MI</b> Malleable Iron

Code	<b>E</b> Pressure Seal	<b>F</b> Dust Seal	<b>G</b> Retainers	<b>H</b> Ball Bearings	<b>I</b> Grease
0	Buna N (Standard)	Buna N (Standard)	No Retainers (O-ring Swivel)	Carbon Steel (Standard)	Lithium
1	FKM	FKM	Aluminium (Standard in CS V-ring)	440 Grade SS	FDA Approved/ Food Grade
2	PTFE	.....	PTFE (Standard in SS V-ring)	316 Grade SS	Silicone (Required with EPR Seals)
3	Ethylene Propylene (Requires Silicone Grease)	Ethylene Propylene (Requires Silicone Grease)	.....	.....	.....
4	FDA Buna (O-ring Only)	FDA Buna	.....	.....	.....

The swivel should be packed such that the surfaces coming in contact with the fluid being handled are compatible with that fluid. In a case where the swivel is being used in a submerged service, this would include the dust seals and ball bearings. We always recommend the use of the stainless steel ball bearings when building a swivel for submerged service. Standard carbon steel ball bearings could rust together, making it impossible to disassemble the swivel, which may affect operation.

# Industrial Hose Fittings

## Split Flange Swivels

B



<b>Application:</b>	<ul style="list-style-type: none"> <li>Used in petroleum, blending plants, petrochemical, refining, mining, distilling, paint plants, farm irrigation and fertilizing, wastewater treatment, food and beverage process equipment, and marine</li> </ul>
<b>Features:</b>	<ul style="list-style-type: none"> <li>Bearing pack design allows easy seal change without removing the ball bearings</li> <li>Simple maintenance: remove one nose piece, replace seal pack, reinstall with little down-time</li> <li>Instream seal separates wetted area from ball bearings allowing for longer bearing pack life over conventional swivels</li> <li>Pressure rating: up to <b>600 PSI</b></li> <li>Temperature: <b>-40°C to 232°C (-40°F to 449°F)</b> depending on seal material (with standard seals: <b>177°C (350°F)</b>)</li> <li>Wide set bearing race for higher moment loads</li> <li>Compact design for low profile applications</li> </ul>
<b>Material:</b>	<ul style="list-style-type: none"> <li>Bearing pack: through hardened forged high carbon alloy</li> <li>Material contact surfaces: stainless steel or carbon steel nose pieces</li> </ul>
<b>Available Options:</b>	<ul style="list-style-type: none"> <li>Stock end configurations: 150 lb. and 300 lb. flanges, FNPT, butt weld, others per request</li> <li>Stock seals: Baylast™, FKM, PTFE, others per request</li> <li>Full penetration weld</li> <li>Contact Dixon™ for additional materials and configurations</li> </ul>

Size	Description	Part No.
2	Carbon steel weld x weld with Baylast™ pressure seals	SF220WXWCS00
3	Carbon steel weld x weld with Baylast™ pressure seals	SF320WXWCS00
4	Carbon steel weld x weld with Baylast™ pressure seals	SF420WXWCS00
2	Carbon steel weld x weld with FKM pressure seals	SF220WXWCS10
3	Carbon steel weld x weld with FKM pressure seals	SF320WXWCS10
4	Carbon steel weld x weld with FKM pressure seals	SF420WXWCS10
2	Carbon steel 150# flange x 150# flange with Baylast™ pressure seals	SF220FGXFGCS00
3	Carbon steel 150# flange x 150# flange with Baylast™ pressure seals	SF320FGXFGCS00
4	Carbon steel 150# flange x 150# flange with Baylast™ pressure seals	SF420FGXFGCS00
2	Carbon steel 150# flange x 150# flange with FKM pressure seals	SF220FGXFGCS10
3	Carbon steel 150# flange x 150# flange with FKM pressure seals	SF320FGXFGCS10
4	Carbon steel 150# flange x 150# flange with FKM pressure seals	SF420FGXFGCS10

### Split Flange Swivel Components

Size (Inch)	Description	Part No.
2	Carbon steel split flange bearing packs	2SFBP
3	Carbon steel split flange bearing packs	3SFBP
4	Carbon steel split flange bearing packs	4SFBP
<b>Split Flange Nose Pieces (2 required per bearing pack)</b>		
2	Carbon steel nose pieces	2SFNPCS
3	Carbon steel nose pieces	3SFNPCS
4	Carbon steel nose pieces	4SFNPCS
2	316 stainless steel nose pieces	2SFNPSS
3	316 stainless steel nose pieces	3SFNPSS
4	316 stainless steel nose pieces	4SFNPSS
<b>Seal Kits (1 required per bearing pack)</b>		
2	Baylast™ seal, PTFE retainer, carbon steel bolts	2SFSK-BAYLAST
3	Baylast™ seal, PTFE retainer, carbon steel bolts	3SFSK-BAYLAST
4	Baylast™ seal, PTFE retainer, carbon steel bolts	4SFSK-BAYLAST
2	FKM seal, PTFE retainer, carbon steel bolts	2SFSK-VI
3	FKM seal, PTFE retainer, carbon steel bolts	3SFSK-VI
4	FKM seal, PTFE retainer, carbon steel bolts	4SFSK-VI
2	PTFE seal, PTFE retainer, carbon steel bolts	2SFSK-TES
3	PTFE seal, PTFE retainer, carbon steel bolts	3SFSK-TES
4	PTFE seal, PTFE retainer, carbon steel bolts	4SFSK-TES



## Dixon™ Loading Arms

<b>Applications:</b>	<ul style="list-style-type: none"> <li>Used in the transfer of liquids and dry bulk in refineries, chemical plants, rail terminals, truck terminals, tote and drum filling, and food industry</li> </ul>
<b>Materials:</b>	<ul style="list-style-type: none"> <li>Various materials available including: hardened carbon steel, 316L stainless steel and aluminium</li> <li>Seals: Buna, EPDM, FKM A and B, PTFE, Baylast, and more on request</li> <li>Counterbalance housing: steel</li> </ul>
<b>Features:</b>	<ul style="list-style-type: none"> <li>TTMA loading arm swivel with heavy duty D style shovel handle</li> <li>TTMA flanges on both ends</li> <li>Shovel handle is used to guide the API load coupler onto the adaptor on the tank truck</li> <li>Long radius elbow improves the flow into the API load coupler and provides spacing between the load arm and the tank truck</li> <li>Can be used with flange extensions</li> <li>Three options for sealing swivels: o-ring, v-ring, and split flange</li> <li>Fast delivery for many sizes and styles</li> <li>Engineered with easy service in mind</li> <li>Wide variety of end configurations available</li> <li>Torsion spring counterbalance:                             <ul style="list-style-type: none"> <li>Ball screw adjustment mechanism for easy and safe adjustment</li> <li>Multiple spring rates available for different load requirements</li> <li>Multiple grease ports for ease of service</li> </ul> </li> </ul>
<b>Sizes:</b>	<ul style="list-style-type: none"> <li>2", 3", 4" and more upon request</li> </ul>



## Dixon™ Loading Arms Swivel Styles

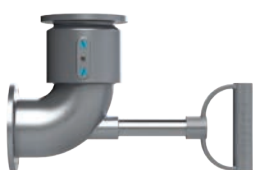

Style 30, short radius



Style 30, long radius



Style 40



Style 50

# Industrial Hose Fittings

## Flow Boss™ Heavy Duty Washdown Gun

New Improved Design!



<b>Application:</b>	<ul style="list-style-type: none"> <li>For low-pressure cleaning and sanitation applications, such as food and dairy processing, tank and drum cleaning, pharmaceutical and chemical manufacturing, and meat and poultry packing</li> </ul>
<b>Specifications:</b>	<ul style="list-style-type: none"> <li>Flow capacity, 57 lpm at 500kpa / <b>72 PSI</b></li> <li>Maximum operating pressure: 2400 kpa / <b>350 PSI</b></li> </ul>
<b>Colour:</b>	<ul style="list-style-type: none"> <li>Blue rubber cover</li> </ul>
<b>Temperature:</b>	<ul style="list-style-type: none"> <li>Rubber-coated handle protects hands from water temperatures to <b>80°C (176°F)</b></li> </ul>
<b>Thread:</b>	<ul style="list-style-type: none"> <li>½" BSP female</li> </ul>
<b>Features:</b>	<ul style="list-style-type: none"> <li>Insulated covers for heat protection</li> <li>All stainless steel and brass construction for superior corrosion resistance</li> <li>Flow indication arrow and arrest clip</li> <li>Hollow cone spray pattern</li> <li>New improved design with high flow rate</li> <li>Increased strength &amp; durability</li> <li>Complete serviceability</li> <li>Upgraded seal design for superior pressure tightness</li> <li>Hose connects at base of gun for easy manoeuvring</li> <li>Ergonomic design for operator comfort, ½" BSP female inlet</li> </ul>

Body	Part No.
Flow Boss™ Gun	FLOBOSS-050

## Trigger Spray Guns



Insulated Water Nozzle

<b>Specifications:</b>	<ul style="list-style-type: none"> <li>Heavy-duty brass valve and adjusting nut</li> <li>Chrome-plated all zinc body</li> <li>Industrial-strength nylon handle</li> <li>Rubber head guard on threaded GHT front version</li> </ul>
<b>Pressure:</b>	<ul style="list-style-type: none"> <li>Max. working pressure: 620 kPa / <b>90PSI</b></li> <li>Max. flow rate: 23 L/min</li> </ul>
<b>Temperature:</b>	<ul style="list-style-type: none"> <li>Hot water up to <b>82°C (179°F)</b></li> </ul>
<b>Thread:</b>	<ul style="list-style-type: none"> <li>Inlet (handle) ¼" BSP female</li> <li>Outlet (nozzle attachment) ¼" GHT</li> </ul>
<b>Feature:</b>	<ul style="list-style-type: none"> <li>Hold open clip locks any spray pattern</li> </ul>

Inlet Thread Size	Outlet Thread Size	Part No.
¼" BSP	GHT	SN75A



Pistol-Grip Water Nozzle

<b>Specifications:</b>	<ul style="list-style-type: none"> <li>Heavy-duty all zinc metallized body</li> <li>All brass valve stem and adjusting nut</li> <li>Stainless-steel spring with lifetime packing</li> <li>Made in USA</li> </ul>
<b>Pressure:</b>	<ul style="list-style-type: none"> <li>Max. working pressure: 620 kPa/90 PSI</li> <li>Max. flow rate: 23 L/min</li> </ul>
<b>Thread:</b>	<ul style="list-style-type: none"> <li>Inlet (handle) ¼" BSP</li> <li>No outlet thread</li> </ul>
<b>Feature:</b>	<ul style="list-style-type: none"> <li>Clip locks any spray pattern, easy squeeze on/off lever</li> </ul>

Inlet Thread Size	Part No.
¼" BSP	CSN75A



Do not use these products with steam lines.



## ADS Outalarms with Probe

Dixon™'s ADS industrial fluid control products are specifically designed for liquid terminal operations. There are numerous additional applications, materials and custom designs available, please visit [europe.dixonvalve.com/ADS](http://europe.dixonvalve.com/ADS) for the latest information.

<b>Application:</b>	<ul style="list-style-type: none"> <li>Specifically designed for liquid terminal operation on batch loading and overflow protection, unloading, tank cars, tank trucks, and marine barges. Suitable for open, and closed dome</li> </ul>
<b>Features:</b>	<ul style="list-style-type: none"> <li>Totally self-contained; no wires, tubing or external power</li> <li>Rugged weather-and corrosion-resistant construction</li> <li>No moving parts, tip sensitive phase shift™ digital capacitance sensor for conductive and non-conductive fluid</li> <li>Intrinsically safe design per ANSI/UL913 for Class I, Div I Groups A, B, C and D Hazardous Areas</li> <li>Requires no calibration or adjustment</li> <li>Operates up to 2500 hours on a single 9V alkaline battery</li> <li>Adjustable insertion length through a standard ½" NPT fitting</li> <li>High intensity audible and flashing visual outputs</li> <li>Full, hard graduated laser engraved rod</li> <li>Fail-safe continuous battery monitor goes to alarm state on low battery</li> <li>Factory tuned to trip ¼" into liquid</li> <li>24", 36", 48" and 60" probe lengths standard, other lengths available</li> <li>Battery current drain &lt;0.23 ma during standby; &lt;50 ma in alarm state</li> <li>Horn intensity 101 dB at 2'</li> <li>Light output: 3 each 3000 mcd high intensity flashing LEDs</li> <li>Wetted materials: 316 stainless steel, PTFE standard, other materials available</li> <li>Pressure rating on standard unit: <b>50 PSI</b>, consult Dixon™ for applications up to <b>300 PSI</b></li> <li>Optional opto-isolated solid state contact output</li> <li>High temperature applications to <b>162°C (325°F)</b></li> <li>Low temperature option good to <b>-40°C (-40°F)</b></li> <li>Temperature range: <b>-26°C to 163°C (-14°F to 325°F)</b></li> </ul> <p><b>A100 Probe:</b></p> <ul style="list-style-type: none"> <li>Capacitance phase shift probe</li> <li>½" NPT gland standard</li> <li>Minimum dielectric constant 1.8</li> <li>Temperature range: <b>-26°C to 121°C (-14°F to 250°F)</b></li> </ul>



ADS Outalarms with A100 Probe

Length (inch)	Capacitance 121°C (250°F) maximum	Hi-temp Capacitance 163°C (325°F) maximum	Conductivity for conductive fluids
12	A100C12A	A100HC12A	A100CSS12A
24	A100C24A	A100HC24A	A100CSS24A
36	A100C36A	A100HC36A	A100CSS36A
48	A100C48A	A100HC48A	A100CSS48A
60	A100C60A	A100HC60A	A100CSS60A
72	A100C72A	A100HC72A	A100CSS72A
84	A100C84A	A100HC84A	A100CSS84A

## King™ Combination Nipples - BSP

### Features:

- Unplated steel and plated steel in sizes 15mm - 50mm are knurled. 316 Stainless Steel in sizes 15mm - 50mm are not knurled

B



### Plated Steel BSP Thread

Size (inch)	Size (mm)	Part No.
½	15	STC1A
¾	20	STC5A
1	25	STC10A
1¼	32	STC15A
1½	40	STC20A
2	50	STC25A
2½	65	STC30A
3	75	STC35A
4	100	STC40A
5	125	STC50A
6	150	STC60A
8	200	STC80A
10	250	STC100A
12	300	STC120A

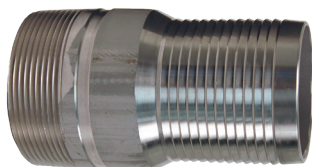

### 316 Stainless Steel BSP Ends

Size (inch)	Size (mm)	Part No.
½	15	RST1A
¾	20	RST5A
1	25	RST10A
1¼	32	RST15A
1½	40	RST20A
2	50	RST25A
2½	65	RST30A
3	75	RST35A
4	100	RST40A
5	125	RST50A
6	150	RST60A
8	200	RST80A

## King™ Combination Nipples - NPT



### NPT Thread

Size (inch)	Size (mm)	Plated Steel Part No.	Stainless Steel Part No.	Aluminium Part No.	Brass Part No.
½	15	STC1	RST1	AST1	BST1
¾	20	STC5	RST5	AST5	BST5
1	25	STC10	RST10	AST10	BST10
1¼	32	STC15	RST15	AST15	BST15
1½	40	STC20	RST20	AST20	BST20
2	50	STC25	RST25	AST25	BST25
2½	65	STC30	RST30	AST30	BST30
3	75	STC35	RST35	AST35	BST35
4	100	STC40	RST40	AST40	BST40
5	125	STC50	RST50	AST50	---
6	150	STC60	RST60	AST60	---
8	200	STC80	RST80	---	---
10	250	STC100	---	---	---
12	300	STC120	---	---	---



- Combination nipples are recommended for low-pressure discharge and suction service for compatible liquids. **They are not for compressible products such as air or nitrogen on sizes 1¼" and above.**
- **King™ combination nipples are not recommended for steam.** The working pressure may vary with the construction of hose, the type of clamping system used, and the application. Consult Dixon™ for recommendations.
- Not intended for compressed air.

# Industrial Hose Fittings

## King™ Combination Nipples

Size (inch)	Size (mm)	Pipe OD (mm)	Unplated Steel Grooved Ends	Plated Steel Shouldered Ends
			Part No.	Part No.
1	25	33.4	STV10	---
1¼	32	42.2	STV15	---
1½	40	48.3	STV20	---
2	50	60.3	STV25	STVS25
2½	65	76.1	STV30-M	---
3	75	88.9	STV35	STVS35
4	100	114.3	STV40	STVS40
5	125	139.7	STV50	---
6	150	165.1	STV60-M	STVS60-M
8	200	219.1	STV80	STVS80
10	250	273.0	STV100	STVS100
12	300	323.9	STV120	STVS120

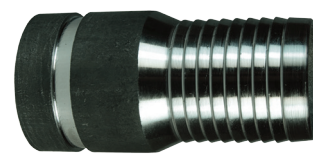

Grooved

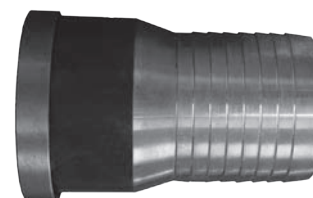

Shouldered



Size (inch)	Size (mm)	Pipe OD (mm)	Unplated Steel Bevelled Ends	316 Stainless Steel Bevelled Ends
			Part No.	Part No.
¾	20	26.7	STB5	RSTB5
1	25	33.4	STB10	RSTB10
1¼	32	42.2	STB15	RSTB15
1½	40	48.3	STB20	RSTB20
2	50	60.3	STB25	RSTB25
2½	63.5 (USA)	73.0	---	RSTB30
2½	65	76.1	STB30-M	RSTB30-M
3	75	75.0	STB35	RSTB35
4	125	139.7	STB50	---
5	150	168.0	---	RSTB60
6	150	165.1	STB60-M	RSTB60-M
8	200	219.1	STB80	---
10	250	273.0	STB100	---
12	300	323.9	STB120	---

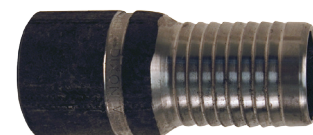

Grooved and bevelled ends (in brass and aluminium) available in selected sizes. Consult Dixon™ for prices and availability.

- Combination nipples are recommended for low-pressure discharge and suction service for compatible liquids. **They are not for compressible products such as air or nitrogen on sizes 1¼" and above.**
- King™ combination nipples are not recommended for steam.** The working pressure may vary with the construction of hose, the type of clamping system used and the application. Consult Dixon™ for recommendations.
- Not intended for compressed air

# Industrial Hose Fittings

## King™ Combination Nipples

B



Series FHS - Steel Welded Flanged Hose Spigots

Size (inch)	Size (mm)	Table D Part No.	Table E Part No.	ANSI 150 Part No.	PN 16 Part No.
½	15	50DFHT	---	50ASAFHT	50NP16FHT
¾	20	75DFHT	---	75ASAFHT	75NP16FHT
1	25	100DFHT	---	100ASAFHT	100NP16FHT
1¼	32	125DFHT	---	125ASAFHT	125NP16FHT
1½	40	150DFHT	---	150ASAFHT	150NP16FHT
2	50	200DFHT	---	200ASAFHT	200NP16FHT
2½	65	250DFHT	---	250ASAFHT	250NP16FHT
3	75	300DFHT	---	300ASAFHT	300NP16FHT
4	100	400DFHT	400EFHT	400ASAFHT	400NP16FHT
5	125	500DFHT	500EFHT	500ASAFHT	500NP16FHT
6	150	600DFHT	600EFHT	600ASAFHT	600NP16FHT
8	200	800DFHT	800EFHT	800ASAFHT	800NP16FHT
10	250	1000DFHT	1000EFHT	1000ASAFHT	1000NP16FHT
12	300	1200DFHT	1200EFHT	1200ASAFHT	1200NP16FHT

Series FHS - 316 Stainless Steel Welded Flanged Hose Spigots

Size (inch)	Size (mm)	Table D Part No.	ANSI 150 Part No.	PN 16 Part No.
1	25	100DFHTSS	100ASAFHTSS	100NP16FHTSS
1¼	32	125DFHTSS	125ASAFHTSS	125NP16FHTSS
1½	40	150DFHTSS	150ASAFHTSS	150NP16FHTSS
2	50	200DFHTSS	200ASAFHTSS	200NP16FHTSS
2½	65	250DFHTSS	250ASAFHTSS	250NP16FHTSS
3	75	300DFHTSS	300ASAFHTSS	300NP16FHTSS
4	100	400DFHTSS	400ASAFHTSS	400NP16FHTSS

Flanged hosetails available in swivel on request

## Male NPTF x Hose Barb



### Features:

- Optional package quantity
- Also available in BSP thread

Hose ID (inch)	Male NPT (inch)	316 Stainless Steel Part No.	Pkg Qty
⅛	⅛	RN11	100
3/16	⅛	RN151	100
	¼	RN152	100
¼	⅛	RN21	100
	¼	RN22	100
	⅜	RN23	100
5/16	⅛	RN251	100
	¼	RN252	50
	⅜	RN253	50
⅜	⅛	RN31	100
	¼	RN32	100
	⅜	RN33	50
	½	RN34	25
½	¼	RN42	50
	⅜	RN43	50
	½	RN44	25
⅝	¾	RN46	25
	⅜	RN53	50
	½	RN54	25
¾	¾	RN56	25
	½	RN64	25
1	¾	RN66	20
	¾	RN86	20
1	1	RKHN881	10

## Lugged Water Couplings - King Shank Serrated Tail

<b>Sizes:</b>	• ½" - 4"
<b>Material:</b>	• Brass, ductile iron, malleable iron, 316 stainless steel, polypropylene
<b>Details:</b>	• Suction and delivery hose couplings - BSP PI. parallel thread only

Brass Male	
Size (inch)	Part No.
½	KSM050B
¾	KSM075B
1	KSM100B
1¼	KSM125B
1½	KSM150B
2	KSM200B
2½	KSM250B
3	KSM300B
4	KSM400B



B

Brass Female	
Size (inch)	Part No.
½	KSF050B
¾	KSF075B
1	KSF100B
1¼	KSF125B
1½	KSF150B
2	KSF200B
2½	KSF250B
3	KSF300B
4	KSF400B



Ductile Iron Male	
Size (inch)	Part No.
1¼	KSM125M
1½	KSM150M
2	KSM200M
2½	KSM250M
3	KSM300M
4	KSM400M



Ductile Iron Female	
Size (inch)	Part No.
1¼	KSF125M
1½	KSF150M
2	KSF200M
2½	KSF250M
3	KSF300M
4	KSF400M



## Lugged Water Couplings - King Shank Serrated Tail

B



Stainless Steel Hexagon Male	
Size (inch)	Part No.
1	KSM100SS
1¼	KSM125SS
1½	KSM150SS
2	KSM200SS
2½	KSM250SS
3	KSM300SS
4	KSM400SS



Stainless Steel Lug Nut Female	
Size (inch)	Part No.
1	KSF100SS
1¼	KSF125SS
1½	KSF150SS
2	KSF200SS
2½	KSF250SS
3	KSF300SS
4	KSF400SS



Rubber Washer

Rubber Washer	
Size (mm)	Part No.
12	KRW1
20	KRW5
25	KRW10
32	KRW15
40	KRW20
50	KRW25
65	KRW30
75	KRW35
100	KRW40



Not intended for compressed air.

## GEKA type Brass Quick Couplings

<b>Sizes:</b>	• ¾" - 1½"
<b>Pressure:</b>	• Maximum working pressure 45 PSI / 3 Bar
<b>Brass Male Hose End</b>	
Size (inch)	Part No.
¾	REHE038B
½	REHE050B
¾	REHE075B
1	REHE100B
1¼	REHE125B
1½	REHE150B
<b>Brass Female Hose End</b>	
Size (inch)	Part No.
¾	REF038B
½	REF050B
¾	REF075B
1	REF100B
1¼	REF125B
1½	REF150B
<b>Blank Cap</b>	
	<b>Part No.</b>
	REBCB
<b>Gasket</b>	
	<b>Part No.</b>
	RESG



B

## Smooth Tail with Safety Clamp Collar

Hose ID (mm)	Wall Thickness (mm)	Aluminium Part No.	Stainless Steel Part No.
13	6	SC13X6AL	---
19	6	SC19X6AL	SC19X6SS
25	6	SC25X6AL	SC25X6SS
32	6	SC32X6AL	---
38	6.5	SC38X6.5AL	SC38X6.5SS
38	8	SC38X8AL	SC38X8SS
38	10	SC38X10AL	---
50	6	---	SC50X6SS
50	8	SC50X8AL	SC50X8SS
50	10	SC50X10AL	SC50X10SS
63	8	SC63X8AL	SC63X8SS
65	7	---	SC65X7SS
65	10	SC65X10AL	---
75	7.5	SC75X7.5AL	SC75X7.5SS
75	10	SC75X10AL	---
100	8	SC100X8AL	---
100	10	SC100X10AL	---
100	12	SC100X12AL	---
150	10	SC150X10AL	---



- The first number in the part number denotes the inside diameter of the hose that the clamp will suit.
- The second number denotes the wall thickness. i.e. SC50X8AL will suit a 50mm ID hose with an 8mm wall thickness (66mm OD).

## Dixon™ Steel Hose Menders

B



Size (inch)	Size (mm)	Zinc Plated Steel Part No.	316 Stainless Steel Part No.	Pkg Qty
¼	6	DMA	RDMA	200
⅜	10	DMB	RDMB	100
½	12	DM1	RDM1	50
⅝	16	DM5	---	50
¾	20	DM6	RDM6	50
1	25	DM11	RDM11	50
1¼	32	DM16	RDM16	50
1⅝	35	DM18	---	50
1½	40	DM21	RDM21	50
1½	40	DMXL21 <sup>1</sup>	---	25
2	50	DM26	RDM26	50
2	50	DMXL26 <sup>1</sup>	---	25
2½	65	DM31	---	25
3	75	DM36	RDM36	20
4	100	DM46	RDM46	10
5	125	DM51	---	5
6	150	DM66	---	4
8	200	DM86	---	1
10	250	DM100	---	1
12	300	DM120	---	1

<sup>1</sup> XL series is extra long



They are not for compressible products such as air, nitrogen, or steam. The working pressure may vary with the construction of the hose, the type of clamping system used, and the application. Consult Dixon™ for recommendations.

## Boss™ Hose Menders



Size (inch)	Size (mm)	Part No.
½	15	M1
¾	20	M6
1	25	M11
1¼	32	M16
1½	40	M21
2	50	M26
2½	65	M31
3	75	M36

Collars to engage grip fingers of Boss™ clamps in this catalogue.  
 20mm - 100mm: plated iron  
 15mm & 150mm: plated steel



## King™ Hose Menders



- Not for compressible products such as air, nitrogen, or steam
- The working pressure may vary with the construction of the hose, the type of clamping system used and the application. Consult Dixon™ for recommendations.
- In accordance with the ARPM bulletin for oil suction and discharge hose, a coupled length of hose in any size should be tested to 1½ times the working pressure and held for fifteen minutes without leaking or coupling movement. For additional information and detailed instruction on testing procedures, see the ARPM handbook or visit ARPMINC.com.

### For One Clamp

Size (inch)	Steel Part No.
1/4	KM21
5/16	KM251
1/2	KM41
5/8	KM51
3/4	KM61
1	KM81
1-1/4	KM101
1-1/2	KM121



### For Two Clamp

Size (inch)	Steel Part No.
½	KM42
¾	KM52
¾	KM62
1	KM82
1¼	KM102
1½	KM122
2	KM162



## Barbed Hose Menders

Hose ID (inch)	Brass Part No.
¼	1780202C
3/16	1780303C
¼ x ¼	1780402C
¼	1780404C
5/16	1780505C
¾ x ¼	1780604C
¾	1780606C
½ x ¾	1780806C
½	1780808C
¾ x ¾	1781006C
¾ x ½	1781008C
¾	1781010C
¾ x ½	1781208C
¾	1781212C
1	1781616C



## Short Shank Menders

Size (inch)	Length (inch)	Length (mm)	316 Stainless Steel Part No.
¼	2-1/32	51.6	RM2
¾	2-1/16	52.4	RM3
½	2-1/16	52.4	RM4
¾	2-1/2	63.5	RM6



B

## Foot Valves, Skimmers & Strainers

B

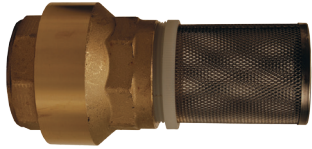

Foot Valve (Spring Loaded)

Thread Size (inch)	Thread	Part No.
3/8	BSP Pl.	FVS038EU
1/2	BSP Pl.	FVS050EU
3/4	BSP Pl.	FVS075EU
1	BSP Pl.	FVS100EU
1 1/4	BSP Pl.	FVS125EU
1 1/2	BSP Pl.	FVS150EU
2	BSP Pl.	FVS200EU
2 1/2	BSP Pl.	FVS250EU
3	BSP Pl.	FVS300EU
4	BSP Pl.	FVS400EU



Cast Iron Foot Valve

Size (inch)	BSP Pl. Thread Part No.	NPT Thread Part No.
2	FVS200CI	DFVS25
3	FVS300CI	DFVS35
4	FVS400CI	DFVS40



Standard - Threaded Type - Round Hole

Size (inch)	Thread	Steel Part No.	304 Stainless Steel Part No.
1 1/2	NPT	RHS20	RRHS20
2	NPT	RHS25	RRHS25
2 1/2	NPT	RHS30	RRHS30
3	NPT	RHS35	RRHS35
4	NPT	RHS40	RRHS40
5	NPT	RHS50	---
6	NPT	RHS60	RRHS60
8	NPT	RHS80	---
10	NPT	RHS100	---
12	NPT	RHS120	---

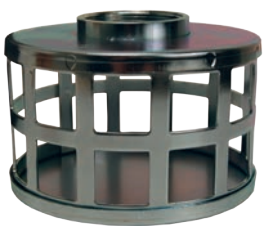

Standard - Threaded NPT Type

Size (inch)	Thread	Steel Part No.
1 1/2	NPT	SHS20
2	NPT	SHS25
3	NPT	SHS35
4	NPT	SHS40
6	NPT	SHS60



Hose Shanks - Round Hole

Size (inch)	Thread	Steel Part No.
1	NPT	TCS100
1 1/2	NPT	TCS150
2	NPT	TCS200
3	NPT	TCS300
4	NPT	TCS400
6	NPT	TCS600

## Foot Valves, Skimmers & Strainers

Long Thin - Round Hose Type		
Size (inch)	Thread	Zinc Plated Steel Part No.
1½	NPT	RSS20
2	NPT	RSS25
2½	NPT	RSS30
3	NPT	RSS35
4	NPT	RSS40



Black Polyethylene Strainer		
Size (inch)	Thread	Black Polypropylene with 30% Fibreglass Part No.
1½	NPT	TSS20
2	NPT	TSS25
3	NPT	TSS35



Skimmer Top Round Hose Type		
Size (inch)	Thread	Steel Part No.
1½	NPT	DST20
2	NPT	DST25
3	NPT	DST35



## Agri-Lock Bauer Style Couplings - Standard

B



### Application:

- Irrigation suction and delivery hose connectors
- Heavy-duty mining suction and delivery slurry line connectors
- Medium vacuum line connectors
- Waste water suction and delivery line connectors

### Features:

- Quick connect and disconnect
- Hot dipped galvanised
- Up to 30° bending angle at the coupling joint whilst maintaining maximum flow
- Ideal for difficult sites
- Rubber seal provides an excellent seal under both pressure and vacuum
- Also available in stainless steel with oil and heat resistant seals
- Heavy-duty machined tails for extra-heavy-duty applications where reduced distortion may be required
- Up to 12 bar working pressure

### Lever Ring

Size (inch)	Part No.
2	ALC2
3	ALC3
4	ALC4
5	ALC5
6	ALC6
8	ALC8

### Male Spigot

Size (inch)	Part No.
2	ALM2
3	ALM3
4	ALM4
5	ALM5
6	ALM6
8	ALM8

### Female Spigot

Size (inch)	Part No.
2	ALF2
3	ALF3
4	ALF4
5	ALF5
6	ALF6
8	ALF8

Rubber O-ring not included.

## Agri-Lock Bauer Style Couplings - Standard

O-Ring	
Size (inch)	Part No.
2	ALO2
3	ALO3
4	ALO4
5	ALO5
6	ALO6
8	ALO8



**B**

Male Flange			
Size (inch)	NP16 Part No.	Table D Part No.	Table E Part No.
2	ALMF2NP16	ALMF2D	ALMF2E
3	ALMF3NP16	ALMF3D	ALMF3E
4	ALMF4NP16	ALMF4D	ALMF4E
5	ALMF5NP16	ALMF5D	ALMF5E
6	ALMF6NP16	ALMF6D	ALMF6E
8	ALMF8NP16	ALMF8D	ALMF8E



Female Flange			
Size (inch)	NP16 Part No.	Table D Part No.	Table E Part No.
2	ALFF2NP16	ALFF2D	ALFF2E
3	ALFF3NP16	ALFF3D	ALFF3E
4	ALFF4NP16	ALFF4D	ALFF4E
5	ALFF5NP16	ALFF5D	ALFF5E
6	ALFF6NP16	ALFF6D	ALFF6E
8	ALFF8NP16	ALFF8D	ALFF8E



Weld-on Female (Not Plated)	
Size (inch)	Part No.
2	ALFW2
3	ALFW3
4	ALFW4
6	ALFW6
8	ALFW8



Rubber O-ring not included.

Weld-on Male (Not Plated)	
Size (inch)	Part No.
2	ALMW2
3	ALMW3
4	ALMW4
6	ALMW6
8	ALMW8



# Industrial Hose Fittings

## Agri-Lock Bauer Style Couplings - Standard

B



Blank Ends		
Size (inch)	Female Part No.	Male Part No.
2	ALFB2	ALMB2
3	ALFB3	ALMB3
4	ALFB4	ALMB4
6	ALFB6	ALMB6
8	ALFB8	ALMB8



Complete Sets	
Size (inch)	Male Part No.
2	ALCS2
3	ALCS3
4	ALCS4
5	ALCS5
6	ALCS6
8	ALCS8

A full range of configurations are available. See the website or speak to the Dixon™ team for more details.

## Boss™ Coupling System

<b>Application:</b>	<ul style="list-style-type: none"> <li>• Boss™ couplings supply a convenient threaded fitting needed to connect two lengths of hose, or a single length to a male or female threaded (NPT/ BSP) outlet.</li> </ul>
<b>Features:</b>	<ul style="list-style-type: none"> <li>• The spud part of the coupling serves as one half of the connection and is usually fixed to the equipment. The stem part that is clamped to the hose is the other half. The two halves are connected or disconnected by rotating the wing nut on the spud. When connected, they achieve a mechanical as well as a pressure seal.</li> </ul>
<b>Services:</b>	<ul style="list-style-type: none"> <li>• Boss™ couplings are all-purpose hose couplings, universally recommended for steam hose connections. They are also widely used for air, water, fluid petroleum chemicals, and liquid petroleum gas up to 1" ID. Boss™ couplings can be applied to many types of rubber, synthetic, plastic, metallic, or semi-metallic hose. Consult your local Dixon™ branch for specific media capabilities.</li> </ul>

B

### Female X Male Hose Assembly

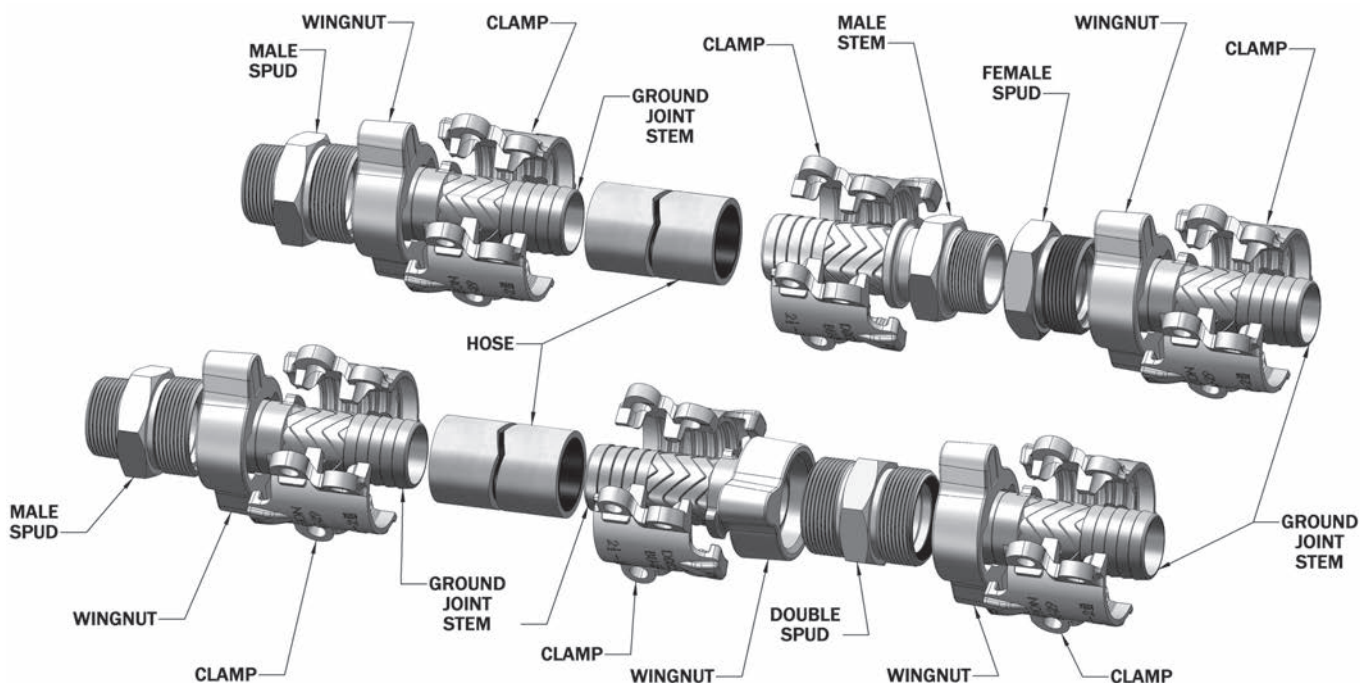

### Female X Female Hose Assembly

## Boss™ Technical Information

Boss™ Couplings Working Pressure Ratings

Size (inch)	Air		Water		Steam	
	PSI	MPa	PSI	MPa	PSI	MPa
¼ to 2	600	4.1	600	4.1	250	1.7
2½ and 3	450	3.1	450	3.1	250	1.7
4 and 6	250	1.7	250	1.7	250	1.7

Material	¼" to 1" Include	1½" to 6" Include
stems	Plated Steel	Plated Malleable Iron through 100 mm tubular steel - 150 mm
spuds	Plated Steel	Plated Malleable Iron
wing nuts	Plated Malleable Iron	Plated Malleable Iron

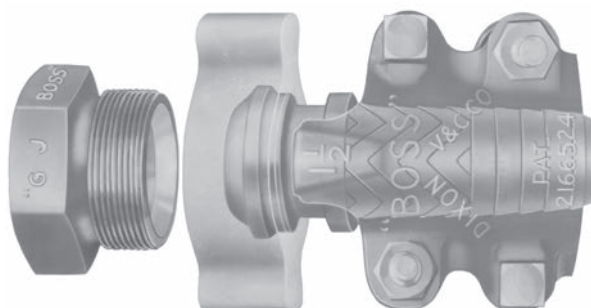

### GROUND JOINT Positive Metal-to-Polymer Seal

- A leakproof seal is formed when the metal head of the stem makes contact with the patented polymer seat in the spud
- The non-metallic polymer seat resists most chemicals found in manufacturing facilities
- Recommended for steam service up to **230°C (446°F)**
- Easy to seal
- Plated steel and/or malleable iron
- Use with Dixon™ Boss™ clamps, refer to pages 109-110

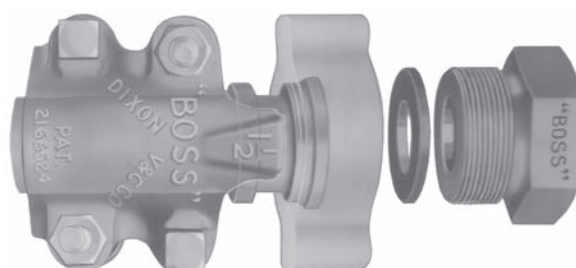

### Washer Type

- A Klinger washer is inserted between the stem and spud
- A leak proof seal is formed by rotating the wing nut and hammering it tight
- Plated steel and/or malleable iron



Worn-out hose couplings can be dangerous. They should be checked regularly and replaced when necessary. Each coupling user should review applications and add safety devices where indicated.



## Boss™ Ground Joint Seal

### GROUND JOINT Positive Metal-to-Polymer Seal

- Positive metal-to-polymer seal
- Leakproof seal forms when the metal head of the stem makes contact with the patented polymer seat in the spud
- Non-metallic polymer seat resists most chemicals found in manufacturing facilities (reference corrosion resistance chart on pages 341-347)
- Recommended for steam service up to **230°C (446°F)**
- Easy to seal
- Plated steel and/or iron
- Use with Boss™ clamps in this catalogue

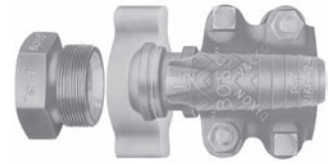

B

### Couplings with Female Spud

Size (inch)	Size (mm)	NPT			BSP
		Plated Steel and/or Iron	316 Stainless Steel	Brass	Plated Steel
		Part No.	Part No.	Part No.	Part No.
¼	6 <sup>1</sup>	GF1 <sup>1</sup>	---	---	GF1A
⅜	9.5 <sup>1</sup>	GF3 <sup>1</sup>	---	---	GF3A
½	15	GF6	---	---	GF6A
¾	20	GF26	RGF26	BGF26	GF26A
1	25	GF36	RGF36	BGF36	GF36A
1¼	32	GF51	RGF51	BGF51	GF51A
1½	40	GF61	RGF61	BGF61	GF61A
2	50	GF81 <sup>2</sup>	RGF81 <sup>2</sup>	BGF81	GF81A
2½	65	GF96	---	---	GF96A
3	75	GF111	---	---	GF111A
4	100	GF141	---	---	GF141A

<sup>1</sup> ¼", ⅜", and 6" available only with copper seat spuds  
<sup>2</sup> Not to be used with #250, #275 or #306 Boss™ clamps

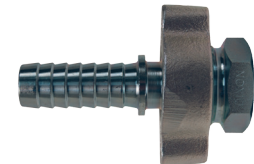

plated iron / steel



316 stainless steel

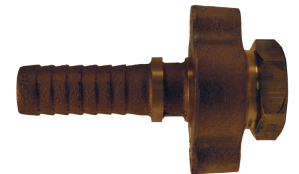

brass



plated iron / steel



316 stainless steel



brass

### Stem

Size (inch)	Size (mm)	Plated Steel and/or Iron	316 Stainless Steel	Brass
		Part No.	Part No.	Part No.
¼	6 <sup>1</sup>	GBA <sup>1</sup>	---	---
⅜	9.5 <sup>1</sup>	GCA <sup>1</sup>	---	---
½	15	GB1	---	---
¾	20	GB6	RGB6	BGB6
1	25	GB11	RGB11	BGB11
1¼	32	GB16	RGB16	---
1½	40	GB21	RGB21	---
2	50	GB26 <sup>2,4</sup>	RGB26 <sup>2</sup>	---
2½	65	GB31	---	---
3	75	GB36 <sup>3</sup>	---	---
4	100	GB46	---	---
6	150*	GB66 <sup>1</sup>	---	---

<sup>1</sup> ¼", ⅜" and 6" available only with copper seat spuds  
<sup>2</sup> Not to be used with #250, #275, or #306 Boss™ clamps  
<sup>3</sup> GB36 has a machined shank to accept a Boss™ clamp, King Crimp™ sleeve, or a ferrule  
<sup>4</sup> GB26 will be replaced with GB26CR. This replacement part will have a machined hose shank to accommodate a Boss™ clamp, King Crimp™ sleeve, or ferrule



\*6mm, 9.5mm and 150mm come only with copper seat spuds. \*\*Not to be used with #250, #275, or #306 Boss™ clamps.  
 • Boss™ couplings and the steam quick disconnects are the only Dixon™ couplings recommended for steam service.

## Boss™ Ground Joint Seal

B

Female Spud  
& Wing Nut  
Thread

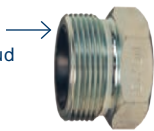

Female Spud					
Size (inch)	Size (mm)	NPT			BSP
		Plated Steel and/ or Iron	316 Stainless Steel	Brass	Plated Steel
		Part No.	Part No.	Part No.	Part No.
¼	6 <sup>1</sup>	GBC <sup>1</sup>	---	---	---
⅜	9.5 <sup>1</sup>	GCC <sup>1</sup>	---	---	GCCA <sup>1</sup>
½	15	GB3	---	---	GB3A
¾	20	GB8	RGB8	BGB8	GB8A
1	25	GB13	RGB13	BGB13	GB13A
1¼	32	GB18	RGB18	---	GB18A
1½	40	GB23	RGB23	---	GB23A
2	50	GB28	RGB28	---	GB28A
2½	65	GB33	---	---	GB33A
3	75	GB38	---	---	GB38A
4	100	GB48	---	---	GB48A
6	150 <sup>1</sup>	GB68	---	---	GB68A

<sup>1</sup> ¼", ⅜" and 6" available only with copper seat spuds; all other sizes have polymer seats

Male Spud  
& Wing Nut  
Thread



Male Spud					
Size (inch)	Size (mm)	NPT			BSP
		Plated Steel and/ or Iron	Plated Steel	Plated Iron	Plated Steel
		Part No.	Part No.	Part No.	Part No.
¼	6 <sup>1</sup>	GMB <sup>1</sup>	---	---	GMBA <sup>1</sup>
⅜	9.5 <sup>1</sup>	---	GMC <sup>1</sup>	---	GMCA <sup>1</sup>
½	15	---	GM3	---	GM3A
¾	20	---	GM8	---	GM8A
1	25	---	GM13	---	GM13A
1¼	32	---	---	GM18	GM18A
1½	40	---	---	GM23	GM23A
2	50	---	---	GM28	GM28A
2½	65	---	---	GM33	GM33A
3	75	---	---	GM38	GM38A

<sup>1</sup> ¼", ⅜" and 6" available only with copper seat spuds; all other sizes have polymer seats

Double Spud  
& Wing Nut  
Thread



Double Spud			
Size (inch)	Size (mm)	Plated Steel	Plated Iron
		Part No.	Part No.
½	15	GDB3	---
¾	20	GDB13	---
1	25		
1¼	32	---	GDB23
1½	40	---	GDB28
2	50	---	GDB33
2½	65	---	GDB38
3	75	---	GDB38



• 6mm, 9.5mm and 150mm come only with copper seat spuds. \*\*Not to be used with #250, #275, or #306 Boss™ clamps  
• Boss™ couplings and the steam quick disconnects are the only Dixon™ couplings recommended for steam service

## Boss™ Washer Seal

### Washer Type

- Recommended for steam service up to **230°C (446°F)**
- Easy to seal
- Klingersil® C-4401 washer is inserted between the stem and spud
- Leakproof seal forms by rotating the wing nut and hammering it tight
- Plated steel and/or iron
- Use with Boss™ clamps in this catalogue

### Coupling with Female Spud

Size (inch)	Size (mm)	Part No.
¾	9.5	WF3
½	15	WF6
¾	20	WF26
1	25	WF36
1¼	32	WF51
1½	40	WF61
2	50	WF81 <sup>1</sup>
2½	65	WF96
3	75	WF111

### Stem

Size (inch)	Size (mm)	Part No.
¾	20	B6
1	25	B11
1¼	32	B16
1½	40	B21
2	50	B26 <sup>1</sup>
2½	65	B31
3	75	B36

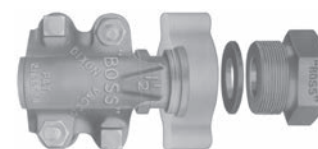

B

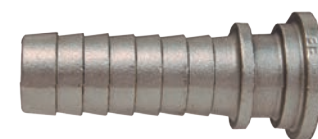

• Not to be used with #250, #275, or #306 Boss™ clamps

## Boss™ Wing Nut for Ground Joint & Washer Seals

### Wing Nut

Size (inch)	Size (mm)	Plated Steel and/or Iron	316 Stainless Steel	Brass
		Part No.	Part No.	Part No.
¾	6*	BA2 <sup>2</sup>	---	---
½	15	B2	---	---
¾	20	B12	RB12	BB12
1	25			
1¼	32	B17	RB17	BB17
1½	40			
2	50	B27	RB27	BB27
2½	65	B32	---	---
3	75	B37	---	---
4	100	B47	---	---
6	150*	B67	---	---

<sup>2</sup> BA2 not for use with the Boss™ washer seal.



plated iron / steel



316 stainless steel



brass



- Washer is a Klingersil® nylon, nitrile bonded, Kevlar reinforced material
- Not to be used with #250, #275, or #306 Boss™ clamps

## Boss™ Washer Seal

B

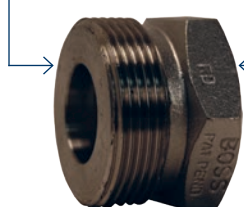
Wing Nut  
ThreadBSP or  
NPT

Female Spud			
Size (inch)	Size (mm)	NPT	BSP
		Part No.	Part No.
3/8	9.5	---	CC
1/2	15	B3	---
3/4	20	B8	---
1	25	B13	---
1 1/4	32	B18	---
1 1/2	40	B23	---
2	50	B28	---
2 1/2	65	B33	---
3	75	B38	---

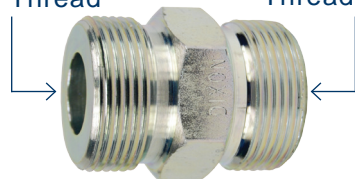
Wing Nut  
ThreadWing Nut  
Thread

Double Spud		
Size (inch)	Size (mm)	Part No.
3/4	20	DB13
1	25	
1 1/4	32	DB23
1 1/2	40	
2	50	DB28
3	75	DB38



Washer		
Size (inch)	Size (mm)	Part No.
3/8	9.5	WBC
3/4	20	W12
1	25	
1 1/4	32	W17
1 1/2	40	
2	50	W27
2 1/2	65	W32
3	75	W37



- Washer is nitrile rubber bonded, non-asbestos Klingersil® C-4401
- Not to be used with #250, #275, or #306 Boss™ clamps

## Ground Joint Accessories Boss™ Adaptors

Boss™ Male NPT Adaptor		
Size (inch)	Size (mm)	Part No.
¾	20	GMAS6
1	25	GMAS11
1½	40	GMAS21
2	50	GMAS26 <sup>1</sup>

<sup>1</sup> GMAS26 takes a special wing nut: **Part No.: B27-3**

<b>Features:</b>	<ul style="list-style-type: none"> <li>• Wing nut is permanently attached on the 1" size</li> <li>• Couplings come with adaptor and wing nuts</li> <li>• These fittings have male or female NPT threads and are designed to fit standard ground joint spuds; refer to page 104</li> </ul>
------------------	---

Boss™ Female NPT Adaptor	
Size (inch)	Part No.
¾	GFAS6
1	GFAS11

## Boss™ Wing Nut Caps

<b>Features:</b>	<ul style="list-style-type: none"> <li>• Boss™ wing nut caps are not intended for pressure applications</li> <li>• For best results, use with washer style spuds and washers</li> <li>• Supplied with 12" chain and washer</li> </ul>
------------------	---

Boss™ Wing Nut & Caps		
Size (inch)	Size (mm)	Part No.
¾ & 1	20 & 25	B12SC
1¼ & 1½	32 & 40	B17SC
2	50	B27SC
3	75	B37SC

## Boss Holedal™ Fittings

<b>Applications:</b>	<ul style="list-style-type: none"> <li>• Designed for air and liquid applications where a permanent, low profile clamping system is desired</li> <li>• Not for steam service</li> </ul>
----------------------	---

<b>Features:</b>	<ul style="list-style-type: none"> <li>• Supplied with carbon steel ferrules</li> <li>• Consult Dixon™ for swage and/or crimp specifications</li> </ul>
------------------	---

Size (inch)	Hose OD From (mm):	Hose OD To (mm):	Plated Iron / Steel	Stainless Steel
			Part No.	Part No.
¾	29.36	30.95	GF26P1	---
	31.35	32.54	GF26P2	---
	32.94	34.13	GF26P3	---
1	37.30	38.89	GF36P1	---
	39.29	39.68	GF36P2	---
	40.87	42.06	GF36P3	---
1½	33.33	50.80	GF61P1	RGF61P1
	51.19	53.97	GF61P2	RGF61P2
	54.37	57.15	GF61P3	---
2	65.08	66.67	GF81P1	RGF81P1
	67.07	69.85	GF81P2	RGF81P2
	70.24	73.02	GF81P3	---
3	86.51	92.07	GF111P1 <sup>1</sup>	---
	92.29	95.25	GF111P2 <sup>1</sup>	---
	95.64	98.42	GF111P3 <sup>1</sup>	---

<sup>1</sup> 3" have a machined shank



## Boss™ Male Stems

B



plated steel

		Steel Bar Stock	
Hose x Thread Size (inch)	Hose x Thread Size (mm)	NPT	BSP
		Part No.	Part No.
¼ x ⅛	6 x 3	MS4X2	---
¼ x ¼	6 x 6	MSA	---
¼ x ⅜	6 x 10	MSB	---
⅜ x ¼	10 x 6	MS6X4	MS6X4A
⅜ x ⅜	10 x 10	MSC	MSCA
⅜ x ½	10 x 15	MS6X8	MS6X8A
½ x ¼	15 x 6	MS8X4	MS8X4A
½ x ⅜	15 x 10	MS8X6	MS8X6A
½ x ½	15 x 15	MS1	MS1A
½ x ¾	15 x 20	MS8X12	MS8X12A
¾ x ½	20 x 15	MS12X8	MS12X8A
¾ x ¾	20 x 20	MS6	MS6A
¾ x 1	20 x 25	MS12X16	MS12X16A
1 x ¾	25 x 20	MS16X12	MS16X12A
1 x 1	25 x 25	MS11	MS11A



plated iron

		Plated Iron	
Size (inch)	Size (mm)	NPT	BSP
		Part No.	Part No.
1¼	32	MS16	MS16A
1½	40	MS21	MS21A
2	50	MS26	MS26A
2½	65	MS31	---
3	75	MS36	MS36A
4	100	MS46	MS46A



316 stainless

		316 Stainless Steel	
Size (inch)	Size (mm)	NPT	BSP
		Part No.	Part No.
½	15	RMS1	RMS1A
¾	20	RMS6	RMS6A
1	25	RMS11	RMS11A
1¼	32	RMS16	RMS16A
1½	40	RMS21	RMS21A
2	50	RMS26	RMS26A
2½	65	RMS31	---
3	75	RMS36	---

• Use with Boss™ clamps; refer to pages 109-110.

## Boss™ Hose Menders



		Plated Steel	
Size (inch)	Size (mm)	Part No.	
		½	15
¾	20	M6	
1	25	M11	
1¼	32	M16	
1½	40	M21	
2	50	M26	
2½	65	M31	
3	75	M36	

Note: Collars to engage grip fingers of Boss™ clamps in this catalogue, refer to pages 109-110.  
20mm - 100mm: plated malleable iron

## 2-Bolt Type Clamp

- Features:**
- Recommended for steam service up to **232°C (450°F)**
  - Recommended torque rating listed in ft.-lbs. and newton-metres
  - Replacement nuts and bolts are available, contact Dixon™ for more information

Hose ID Size (inch)	Hose ID Size (mm)	Hose OD (mm)		Zinc Plated Iron			Stainless Steel			Brass					
				Part No.	Torque <sup>1</sup>		Pkg Qty	Part No.	Torque		Pkg Qty	Part No.	Torque		Pkg Qty
		To	From		lb-ft	Nm			lb-ft	Nm			lb-ft	Nm	
¼	6	14.3	16.7	BD <sup>2</sup>	6	8.1	100	---	-	-	-	---	-	-	-
½	15	20.6	23.8	DD <sup>2</sup>	6	8.1	100	---	-	-	-	---	-	-	-
½	15	23.8	27.0	B4 <sup>2</sup>	12	16.3	25	RB4	12	16.3	25	BB4	10	13.6	25
½	15	27.0	30.2	B5	12	16.3	25	---	-	-	-	---	-	-	-
¾	20	30.2	33.3	BU9 <sup>2</sup>	21	28.5	50	RBU9	21	28.5	50	BBU9	18	24.4	50
¾	20	33.3	38.1	B9	21	28.5	25	RB9	21	28.5	25	---	-	-	-
¾	20	38.1	42.9	B10	21	28.5	25	---	-	-	-	---	-	-	-



B

<sup>1</sup> Torque applies to plated iron and stainless steel clamps  
<sup>2</sup> Investment cast carbon steel  
<sup>3</sup> Not to be used with GF81, GB26, WF81, B26, RGF81, RGB26, BGF81, BGB26, RWF81, RB26

- The bolts used in the Boss™ interlocking clamps are not standard bolts. They vary from standard bolts in their length, diameter, overall thread length, and material hardness. These bolts can be re-torqued, but it is **not** recommended that the bolts or clamps be reused, as they are designed for a single bend only. Dixon™ recommends using only factory-supplied replacement bolts.
- Torque values for clamps are based on dry bolts. The use of lubricant on bolts will adversely affect clamp performance. **Do not lubricate nuts and bolts.**
- For all bolt-tightening sequences, please visit [europe.dixonvalve.com](http://europe.dixonvalve.com)

## Three-Piece Clamp 6-Bolt Type

- Features:**
- Recommended for steam service up to **232°C (450°F)**
  - Recommended torque rating listed in ft.-lbs. and newton-metres
  - Replacement nuts and bolts are available, contact Dixon™ for more information

Zinc Plated Iron							
Hose ID Size (inch)	Hose ID Size (mm)	Hose OD (mm)		Part No.	Torque		Pkg Qty
		From:	To:		lb-ft	Nm	
3	75	108.0	122.2	BS39	150	204	2
4	100	117.5	127.0	B45	150	204	2
4	100	123.8	133.4	BS49	200	272	2
4	100	133.4	142.1	BU49	200	272	2
4	100	140.5	150.8	B49	200	272	2
6	150	174.6	187.3	750	200	272	1
6	150	190.5	203.2	850	200	272	1



- The bolts used in the Boss™ interlocking clamps are not standard bolts. They vary from standard bolts in their length, diameter, overall thread length, and material hardness. These bolts can be re-torqued, but it is **not** recommended that they be reused, as they are designed for a single bend only. Dixon™ recommends using only factory-supplied replacement bolts.
- Torque values for clamps are based on dry bolts. The use of lubricant on bolts will adversely affect clamp performance.
- Do not lubricate nuts and bolts
- Recommended torque rating listed in ft.-lbs. and newton-metres

Dixon™ recommends following correct assembly procedures when installing clamps. These are available from Dixon™ on request. Failure to install clamps correctly may affect performance.

## 4-Bolt Type Clamp

B



2 Gripping Fingers



4 Gripping Fingers



### Zinc Plated Iron

Hose ID Size (inch)	Hose ID Size (mm)	Hose OD (mm)		Part No.	Torque <sup>2</sup>		Pkg Qty
		From:	To:		lb-ft	Nm	
½	15	23.0	26.2	968	6	8.1	50
1	25	35.7	39.7	156 <sup>1</sup>	21	28.5	20
1	25	38.9	43.7	BU14	21	28.5	25
1	25	42.9	49.2	B14	21	28.5	25
1	25	49.2	54.0	B15	21	28.5	20
1¼	32	38.1	45.2	BU18	40	54.2	10
1¼	32	42.9	47.6	187 <sup>1</sup>	21	28.5	10
1¼	32	45.2	53.2	BU19	40	54.2	10
1¼	32	47.6	52.4	206 <sup>1</sup>	21	28.5	20
1¼	32	54.0	60.3	B19	40	54.2	10
1½	40	46.0	50.8	BU22	40	54.2	10
1½	40	50.8	56.4	B22	40	54.2	10
1½	40	50.8	54.0	212 <sup>1</sup>	21	28.5	10
1½	40	52.4	57.2	225 <sup>1</sup>	40	54.2	10
1½	40	55.6	60.3	BU24	40	54.2	10
1½	40	60.3	65.1	B24	40	54.2	10
1½	40	65.1	69.9	B25	40	54.2	10
2	50	57.2	63.5	250 <sup>1,3</sup>	40	54.2	10
2	50	59.5	64.3	BU28	60	81.3	10
2	50	63.5	69.9	275 <sup>1,3</sup>	40	54.2	10
2	50	63.5	70.6	BU29	60	81.3	10
2	50	69.9	77.8	B29	60	81.3	10
2	50	69.9	77.8	306 <sup>1,3</sup>	60	81.3	10
2	50	78.6	87.3	B30	60	81.3	5
2½	65	77.8	88.9	350 <sup>1</sup>	60	81.3	5
2½	65	78.6	87.3	BU34	60	81.3	5
2½	65	88.9	100.0	B34	150	203.4	5
3	75	88.9	95.3	375 <sup>1</sup>	60	81.3	5
3	75	88.9	100.0	BU35	150	203.4	5
3	75	95.3	101.6	401 <sup>1</sup>	150	203.4	5
3	75	96.8	103.2	B35	150	203.4	5
3	75	101.6	106.4	418 <sup>1</sup>	200	271.2	4
3	75	103.2	112.7	B39	200	271.2	5
3	75	106.4	114.3	450 <sup>1</sup>	200	271.2	2

### Stainless Steel

Hose ID Size (inch)	Hose ID Size (mm)	Hose OD		Part No.	Torque <sup>2</sup>		Pkg Qty
		From:	To:		lb-ft	Nm	
1	25	38.9	43.7	RBU14	21	28.5	25
1½	40	55.6	60.3	RBU24	40	54.2	10
1½	40	60.3	65.1	RB24	40	54.2	10
2	50	63.5	70.6	RBU29	60	81.4	10
2	50	69.9	77.8	RB29	60	81.4	10
3	75	88.9	100.0	RBU35	150	203.4	5

### Brass

Hose ID Size (inch)	Hose ID Size (mm)	Hose OD		Part No.	Torque		Pkg Qty
		From:	To:		lb-ft	Nm	
1	25	38.9	43.7	BBU14	18	24.4	25
1	25	42.9	49.2	BB14	28	38.0	25

<sup>1</sup> 4 gripping fingers<sup>2</sup> Torque applies to plated iron and stainless steel clamps<sup>3</sup> Not to be used with GF81, GB26, WF81, B26, RGF81, RGB26, BGF81, BGB26, RWF81, RB26

FOR SAFETY ALERTS PLEASE REFER TO PAGE 109



## Steam Hose Fittings and Couplings - BS EN 14423:2004

<b>Sizes:</b>	<ul style="list-style-type: none"> <li>• DN13 to DN25</li> </ul>
<b>Pressure:</b>	<ul style="list-style-type: none"> <li>• Maximum working pressure: <b>18 Bar</b></li> </ul>
<b>Temperature:</b>	<ul style="list-style-type: none"> <li>• Maximum working temperature: steam <b>210°C (410°F)</b>, hot water <b>120°C (248°F)</b></li> </ul>
<b>Details:</b>	<ul style="list-style-type: none"> <li>• Suitable for fixing to steam hoses to BS EN 14423:2004 with safety clamps</li> <li>• All steam fittings are supplied with corresponding brass safety clamps</li> </ul>

Female Coupling		
Hose Size (inch)	BSP Pl. Thread (inch)	Part No.
13 x 6	½	SCF13x6BR
19 x 7	¾	SCF19x7BR
25 x 7½	1	SCF25x7.5BR

Male Coupling		
Hose Size (inch)	BSP Pl. Thread (inch)	Part No.
13 x 6	½	SCM13x6BR
19 x 7	¾	SCM19x7BR
25 x 7½	1	SCM25x7.5BR

Note: All BS EN 14423:2004 Couplings are available to special order only. Minimum quantities may apply. All couplings supplied with clamp.



B

# Industrial Hose Fittings

## Ordering System

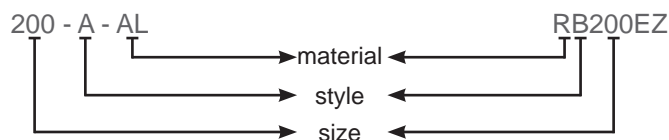

Size represents the coupler or adaptor and hose or pipe end (i.e. 200 = 2"). If the coupling is a reducing size, the coupler or adaptor is the first size (i.e. 4030-C is 4" coupler to 3" hose shank).

## Operation of Cam & Groove

1. To make connection, slide the adaptor into the coupler and with normal hand pressure, press the cam levers down.
2. Uncoupling is as quick and simple as coupling. Just lift the cam arms and remove the adaptor.

## Specifications on Dixon™ Cam & Groove

### Specifications:

- Dixon™, Boss-Lock™, and EZ Boss-Lock™ cam & groove couplers and adaptors are produced to interchange with all product produced to Commercial Item Description A-A-59326D
- No standard exists for the ½", 5", and 8" fittings, and generally these sizes do not interchange with other manufacturers
- Dust caps and dust plugs are **not** to be used in pressure applications for safety and environmental reasons
- **Designed for use with liquids.** Consult Dixon™ for specific recommendations



Recommendations based on the use of mating Dixon™ fittings at ambient temperature 21°C (70°F) with standard Buna-N seal installed. For use at elevated temperature or other unusual operating conditions, consult Dixon™. Maximum working pressure for Dixon™, Boss-Lock™, and EZ Boss-Lock™ couplers and adaptors are as follows:

Size (inch)	½"	¾" to 2"	2½"	3"	4"	5" and 6"	8"
PSI	150	250	150	125	100	75	50
PSI (working pressure with King Crimp™ ferrule system)	150	250	150	150	150	75	50

## Cam & Groove Nominal Take-Up Lengths

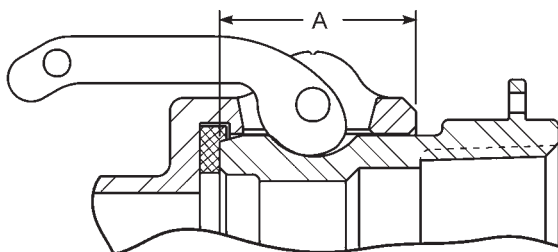

Coupling Size (inch)	Dimension A (inch)
½	0.97
¾	0.97
1	1.20
1¼	1.44
1½	1.50
2	1.81
2½	1.82
3	1.78
4	1.84
5	2.00
6	2.13
8	2.06
8	3.22

## King Crimp™ EZ Boss-Lock™ Cam & Groove Type C

- Features:**
- Couplers are supplied standard with a Buna-N gasket; other gasket types are available. Refer to pages 33-34

Female Coupler x Hose Shank	
Hose ID (inch)	316 Stainless Steel Part No.
1	RC100EZCR
1½	RC150EZCR
2	RC200EZCR
3	RC300EZCR
4	RC400EZCR
6	RC600EZCR



B

 Under no circumstances should the EZ Boss-Lock™ cam arms be used on any fittings not specifically designed for their use.

## Cam & Groove Type C

- Features:**
- All couplers are supplied with safety clips
  - Couplers are supplied standard with a Buna-N gasket; other gasket types are available. Refer to pages 33-34

Female Coupler x Hose Shank			
Hose ID (inch)	A380 Permanent Mould Aluminium	ASTMC 3800 Forged Brass	316 Investment Cast Stainless Steel
	Part No.	Part No.	Part No.
1	G100-C-ALCR	G100-C-BRCR	G100-C-SSCR
1½	G150-C-ALCR	G150-C-BRCR	G150-C-SSCR
2	G200-C-ALCR	G200-C-BRCR	G200-C-SSCR
3	G300-C-ALCR	G300-C-BRCR	G300-C-SSCR
4	G400-C-ALCR	G400-C-BRCR	G400-C-SSCR
6	G600-C-ALCR	---	G600-C-SSCR



## Cam & Groove Type E

Male Adaptor x Hose Shank			
Hose ID (inch)	A380 Permanent Mould Aluminium	ASTMC 3800 Forged Brass	316 Investment Cast Stainless Steel
	Part No.	Part No.	Part No.
1	G100-E-ALCR	G100-E-BRCR	G100-E-SSCR
1½	G150-E-ALCR	G150-E-BRCR	G150-E-SSCR
2	G200-E-ALCR	G200-E-BRCR	G200-E-SSCR
3	G300-E-ALCR	G300-E-BRCR	G300-E-SSCR
4	G400-E-ALCR	G400-E-BRCR	G400-E-SSCR
6	G600-E-ALCR	G600-E-BRCR	G600-E-SSCR



• Refer to crimp sleeves and ferrules on pages 114-117.

 Only use the crimp style shanks with the crimp style sleeves and ferrules.  
 • Due to differences in dimensions and tolerances for safety reasons, DO NOT interchange other manufacturers' products with Dixon™ products.

## King Crimp™ Style Sleeves



- Only use the crimp style shanks with the crimp style sleeves and ferrules.
- Due to differences in dimensions and tolerances for safety reasons, DO NOT interchange other manufacturers' products with Dixon™ products.

Hose ID (inch)	Hose OD (mm)		WP (PSI)		Sleeve ID (mm)	Sleeve Wall Thickness (mm)	Sleeve Overall Length (mm)	Carbon Steel	304 Stainless Steel
	From	To	Cam & Groove <sup>1</sup>	KC Nipple <sup>2</sup>				Part No.	Part No.
1	30.56	31.75	*	*	33.40	1.57	63.5	CS100-1CS	CS100-1SS
1	32.15	33.34	*	*	34.90	1.57	63.5	CS100-2CS	CS100-2SS
1	33.73	34.93	*	*	36.50	1.57	63.5	CS100-3CS	CS100-3SS
1	35.32	36.51	*	*	38.10	1.57	63.5	CS100-4CS	CS100-4SS
1	36.91	38.10	*	*	39.70	1.57	63.5	CS100-5CS	CS100-5SS
1	38.50	39.69	*	*	42.30	1.57	63.5	CS100-6CS	CS100-6SS
1	40.08	41.28	*	*	42.90	1.57	63.5	CS100-7CS	CS100-7SS
1	41.67	42.86	*	*	44.50	1.57	63.5	CS100-8CS	CS100-8SS
1	43.26	44.45	*	*	46.10	1.57	63.5	CS100-9CS	CS100-9SS
1	44.85	46.03	*	*	47.60	1.57	63.5	CS100-10CS	CS100-10SS
1¼	30.56	42.86	<b>250</b>	<b>300</b>	44.45	1.57	63.5	CS125-3CS	CS125-3SS
1¼	43.26	44.45	<b>250</b>	<b>300</b>	46.05	1.57	63.5	CS125-4CS	CS125-4SS
1¼	44.85	46.04	<b>250</b>	<b>300</b>	47.63	1.57	63.5	CS125-5CS	CS125-5SS
1¼	46.43	47.63	<b>250</b>	<b>300</b>	49.23	1.57	63.5	CS125-6CS	CS125-6SS
1½	41.68	42.87	<b>250</b>	<b>300</b>	44.45	1.57	63.5	CS150-1CS	CS150-1SS
1½	43.26	44.45	<b>250</b>	<b>300</b>	46.05	1.57	63.5	CS150-2CS	CS150-2SS
1½	44.85	46.04	<b>250</b>	<b>300</b>	47.63	1.57	63.5	CS150-3CS	CS150-3SS
1½	46.44	47.63	<b>250</b>	<b>300</b>	49.23	1.57	63.5	CS150-4CS	CS150-4SS
1½	48.03	49.22	<b>250</b>	<b>300</b>	50.80	1.57	63.5	CS150-5CS	CS150-5SS
1½	49.61	50.80	<b>250</b>	<b>300</b>	52.40	1.57	63.5	CS150-6CS	CS150-6SS
1½	51.20	52.39	<b>250</b>	<b>300</b>	53.98	1.57	63.5	CS150-7CS	CS150-7SS
1½	52.79	53.98	<b>250</b>	<b>300</b>	55.58	1.57	63.5	CS150-8CS	CS150-8SS
1½	55.96	57.15	<b>250</b>	<b>300</b>	58.75	1.57	63.5	CS150-10CS	CS150-10SS
1½	57.55	58.74	<b>250</b>	<b>300</b>	60.33	1.57	63.5	CS150-11CS	CS150-11SS
1½	59.14	60.33	<b>250</b>	<b>300</b>	61.93	1.57	63.5	CS150-12CS	CS150-12SS
2	55.96	57.15	<b>250</b>	<b>250</b>	58.75	1.57	63.5	CS200-1CS	CS200-1SS
2	57.55	58.74	<b>250</b>	<b>250</b>	60.33	1.57	63.5	CS200-2CS	CS200-2SS
2	60.72	61.91	<b>250</b>	<b>250</b>	63.50	1.57	63.5	CS200-4CS	CS200-4SS
2	62.31	63.50	<b>250</b>	<b>250</b>	65.10	1.57	63.5	CS200-5CS	CS200-5SS
2	63.90	65.09	<b>250</b>	<b>250</b>	66.68	1.57	63.5	CS200-6CS	CS200-6SS
2	65.48	66.68	<b>250</b>	<b>250</b>	68.28	1.57	63.5	CS200-7CS	CS200-7SS
2	67.07	68.26	<b>250</b>	<b>250</b>	69.85	1.57	63.5	CS200-8CS	CS200-8SS
2	68.66	69.85	<b>250</b>	<b>250</b>	71.45	1.57	63.5	CS200-9CS	CS200-9SS
2	70.25	71.44	<b>250</b>	<b>250</b>	73.03	1.57	63.5	CS200-10CS	CS200-10SS
2	71.83	73.03	<b>250</b>	<b>250</b>	74.63	1.57	63.5	CS200-11CS	CS200-11SS
2	73.42	74.61	<b>250</b>	<b>250</b>	76.20	1.57	63.5	CS200-12CS	CS200-12SS

\* Consult Dixon™ for pressure rating.

<sup>1</sup> Based on using crimp cam & groove shanks

<sup>2</sup> Based on using King™ combination nipples

## King Crimp™ Style Sleeves



- Only use the crimp style shanks with the crimp style sleeves and ferrules.
- Due to differences in dimensions and tolerances for safety reasons, DO NOT interchange other manufacturers' products with Dixon™ products.

B

Hose ID (inch)	Hose OD (mm)		WP (PSI)		Sleeve ID (mm)	Sleeve Wall Thickness (mm)	Sleeve Overall Length (mm)	Carbon Steel	304 Stainless Steel
	From	To	Cam & Groove <sup>1</sup>	KC Nipple <sup>2</sup>				Part No.	Part No.
3	81.36	82.55	125	200	84.15	2.29	95.0	CS300-1CS	CS300-1SS
3	82.95	84.14	125	200	85.73	2.29	95.0	CS300-2CS	CS300-2SS
3	84.53	85.73	125	200	87.33	2.29	95.0	CS300-3CS	CS300-3SS
3	86.12	87.31	125	200	88.90	2.29	95.0	CS300-4CS	CS300-4SS
3	89.30	90.49	125	200	92.08	2.29	95.0	CS300-6CS	CS300-6SS
3	90.88	92.08	125	200	93.68	2.29	95.0	CS300-7CS	CS300-7SS
3	92.47	93.66	125	200	95.25	2.29	95.0	CS300-8CS	CS300-8SS
3	94.06	95.25	125	200	96.85	2.29	95.0	CS300-9CS	CS300-9SS
3	95.65	96.84	125	200	98.43	2.29	95.0	CS300-10CS	CS300-10SS
3	97.23	98.43	125	200	100.03	2.29	95.0	CS300-11CS	CS300-11SS
3	98.82	100.01	125	200	101.60	2.29	95.0	CS300-12CS	CS300-12SS
3	100.41	101.60	125	200	103.20	2.29	95.0	CS300-13CS	CS300-13SS
3	102.00	103.19	125	200	104.78	2.29	95.0	CS300-14CS	CS300-14SS
3	103.58	104.78	125	200	106.38	2.29	95.0	CS300-15CS	CS300-15SS
3	105.17	106.36	125	200	107.95	2.29	95.0	CS300-16CS	CS300-16SS
4	106.76	107.95	110	175	109.55	2.29	95.0	CS400-1CS	CS400-1SS
4	108.35	109.54	110	175	111.13	2.29	95.0	CS400-2CS	CS400-2SS
4	109.93	111.13	110	175	112.73	2.29	95.0	CS400-3CS	CS400-3SS
4	111.52	112.71	110	175	114.30	2.29	95.0	CS400-4CS	CS400-4SS
4	113.11	114.30	110	175	115.90	2.29	95.0	CS400-5CS	CS400-5SS
4	114.70	115.89	110	175	117.48	2.29	95.0	CS400-6CS	CS400-6SS
4	116.28	117.48	110	175	119.08	2.29	95.0	CS400-7CS	CS400-7SS
4	117.87	119.06	110	175	120.65	2.29	95.0	CS400-8CS	CS400-8SS
4	119.46	120.65	110	175	122.25	2.29	95.0	CS400-9CS	CS400-9SS
4	121.05	122.24	110	175	123.80	2.29	95.0	CS400-10CS	CS400-10SS
4	122.63	123.83	110	175	125.43	2.29	95.0	CS400-11CS	CS400-11SS
4	124.22	125.41	110	175	127.00	2.29	95.0	CS400-12CS	CS400-12SS
4	125.81	127.00	110	175	128.60	2.29	95.0	CS400-13CS	CS400-13SS
4	127.40	128.59	110	175	130.18	2.29	95.0	CS400-14CS	CS400-14SS
4	128.98	130.18	110	175	131.78	2.29	95.0	CS400-15CS	CS400-15SS
4	130.57	131.76	110	175	133.35	2.29	95.0	CS400-16CS	CS400-16SS
6	157.56	163.51	*	*	165.10	3.05	140.0	CS600-1CS	CS600-1SS
6	163.91	163.91	*	*	168.28	3.05	140.0	CS600-2CS	CS600-2SS
6	167.08	169.86	*	*	171.45	3.05	140.0	CS600-3CS	CS600-3SS
6	170.26	173.04	*	*	174.63	3.05	140.0	CS600-4CS	CS600-4SS
6	173.43	176.21	*	*	177.80	3.05	140.0	CS600-5CS	CS600-5SS
6	176.61	179.39	*	*	180.98	3.05	140.0	CS600-6CS	CS600-6SS
6	179.78	182.56	*	*	184.15	3.05	140.0	CS600-7CS	CS600-7SS
6	182.96	185.74	*	*	187.33	3.05	140.0	CS600-8CS	CS600-8SS
6	186.13	188.91	*	*	190.50	3.05	140.0	CS600-9CS	CS600-9SS

\* Consult Dixon™ for pressure rating

<sup>1</sup> Based on using crimp cam & groove shanks

<sup>2</sup> Based on using King™ combination nipples

## King Crimp™ Style Ferrules



B



- Only use the crimp style shanks with the crimp style sleeves and ferrules.
- Due to differences in dimensions and tolerances for safety reasons, DO NOT interchange other manufacturers' products with Dixon™ products.

Hose ID (inch)	Hose OD (mm)		WP (PSI)		Ferrule ID (mm)	Ferrule Wall Thickness (mm)	Ferrule Overall Length (mm)	Carbon Steel	304 Stainless Steel
	From	To	Cam & Groove <sup>1</sup>	KC Nipple <sup>2</sup>				Part No.	Part No.
1	30.56	31.75	*	*	33.40	2.29	71.4	CF100-1CS	CF100-1SS
1	32.15	33.34	*	*	34.90	2.29	71.4	CF100-2CS	CF100-2SS
1	33.73	34.93	*	*	36.50	2.29	71.4	CF100-3CS	CF100-3SS
1	35.32	36.51	*	*	38.10	2.29	71.4	CF100-4CS	CF100-4SS
1	36.91	38.10	*	*	39.70	2.29	71.4	CF100-5CS	CF100-5SS
1	38.50	39.69	*	*	42.30	2.29	71.4	CF100-6CS	CF100-6SS
1	40.08	41.28	*	*	42.90	2.29	71.4	CF100-7CS	CF100-7SS
1	41.67	42.86	*	*	44.50	2.29	71.4	CF100-8CS	CF100-8SS
1	43.26	44.45	*	*	46.10	2.29	71.4	CF100-9CS	CF100-9SS
1	44.85	46.03	*	*	47.60	2.29	71.4	CF100-10CS	CF100-10SS
1¼	41.67	42.86	<b>250</b>	<b>350</b>	44.45	2.29	71.4	CF125-3CS	CF125-3SS
1¼	43.26	44.45	<b>250</b>	<b>350</b>	69.85	2.29	71.4	CF125-4CS	CF125-4SS
1¼	44.85	46.04	<b>250</b>	<b>350</b>	95.25	2.29	71.4	CF125-5CS	CF125-5SS
1¼	46.43	47.63	<b>250</b>	<b>350</b>	120.65	2.29	71.4	CF125-6CS	CF125-6SS
1½	41.68	42.87	<b>250</b>	<b>350</b>	44.45	2.29	71.4	CF150-1CS	CF150-1SS
1½	43.26	44.45	<b>250</b>	<b>350</b>	46.05	2.29	71.4	CF150-2CS	CF150-2SS
1½	44.85	46.04	<b>250</b>	<b>350</b>	47.63	2.29	71.4	CF150-3CS	CF150-3SS
1½	46.44	47.63	<b>250</b>	<b>350</b>	49.23	2.29	71.4	CF150-4CS	CF150-4SS
1½	48.03	49.22	<b>250</b>	<b>350</b>	50.80	2.29	71.4	CF150-5CS	CF150-5SS
1½	49.61	50.80	<b>250</b>	<b>350</b>	52.40	2.29	71.4	CF150-6CS	CF150-6SS
1½	51.20	52.39	<b>250</b>	<b>350</b>	53.98	2.29	71.4	CF150-7CS	CF150-7SS
1½	52.79	53.98	<b>250</b>	<b>350</b>	55.58	2.29	71.4	CF150-8CS	CF150-8SS
1½	54.38	55.57	<b>250</b>	<b>350</b>	57.15	2.29	71.4	CF150-9CS	CF150-9SS
1½	55.96	57.15	<b>250</b>	<b>350</b>	58.75	2.29	71.4	CF150-10CS	CF150-10SS
1½	57.55	58.74	<b>250</b>	<b>350</b>	60.33	2.29	71.4	CF150-11CS	CF150-11SS
1½	59.14	60.33	<b>250</b>	<b>350</b>	61.93	2.29	71.4	CF150-12CS	CF150-12SS
2	55.96	57.15	<b>250</b>	<b>300</b>	58.75	2.29	79.4	CF200-1CS	CF200-1SS
2	57.55	58.74	<b>250</b>	<b>300</b>	60.33	2.29	79.4	CF200-2CS	CF200-2SS
2	59.13	60.33	<b>250</b>	<b>300</b>	61.93	2.29	79.4	CF200-3CS	CF200-3SS
2	60.72	61.91	<b>250</b>	<b>300</b>	63.50	2.29	79.4	CF200-4CS	CF200-4SS
2	62.31	63.50	<b>250</b>	<b>300</b>	65.10	2.29	79.4	CF200-5CS	CF200-5SS
2	63.90	65.09	<b>250</b>	<b>300</b>	66.68	2.29	79.4	CF200-6CS	CF200-6SS
2	65.48	66.68	<b>250</b>	<b>300</b>	68.28	2.29	79.4	CF200-7CS	CF200-7SS
2	67.07	68.26	<b>250</b>	<b>300</b>	69.85	2.29	79.4	CF200-8CS	CF200-8SS
2	68.66	69.85	<b>250</b>	<b>300</b>	71.45	2.29	79.4	CF200-9CS	CF200-9SS
2	70.25	71.44	<b>250</b>	<b>300</b>	73.03	2.29	79.4	CF200-10CS	CF200-10SS
2	71.83	73.03	<b>250</b>	<b>300</b>	74.63	2.29	79.4	CF200-11CS	CF200-11SS
2	73.42	74.61	<b>250</b>	<b>300</b>	76.20	2.29	79.4	CF200-12CS	CF200-12SS

\* Consult Dixon™ for pressure rating

<sup>1</sup> Based on using crimp cam & groove shanks

<sup>2</sup> Based on using King™ combination nipples

# Industrial Hose Fittings

## King Crimp™ Style Ferrules



B

- Only use the crimp style shanks with the crimp style sleeves and ferrules.
- Due to differences in dimensions and tolerances for safety reasons, DO NOT interchange other manufacturers' products with Dixon™ products.

Hose ID (inch)	Hose OD (mm)		WP (PSI)		Ferrule ID (mm)	Ferrule Wall Thickness (mm)	Ferrule Overall Length (mm)	Carbon Steel	304 Stainless Steel
	From	To	Cam & Groove <sup>1</sup>	KC Nipple <sup>2</sup>				Part No.	Part No.
3	81.36	82.55	150	300	84.15	2.29	101.6	CF300-1CS	CF300-1SS
3	82.95	84.14	150	300	85.73	2.29	101.6	CF300-2CS	CF300-2SS
3	84.53	85.73	150	300	87.33	2.29	101.6	CF300-3CS	CF300-3SS
3	86.12	87.31	150	300	88.90	2.29	101.6	CF300-4CS	CF300-4SS
3	87.71	88.90	150	300	90.50	2.29	101.6	CF300-5CS	CF300-5SS
3	89.30	90.49	150	300	92.08	2.29	101.6	CF300-6CS	CF300-6SS
3	90.88	92.08	150	300	93.68	2.29	101.6	CF300-7CS	CF300-7SS
3	92.47	93.66	150	300	95.25	2.29	101.6	CF300-8CS	CF300-8SS
3	94.06	95.25	150	300	96.85	2.29	101.6	CF300-9CS	CF300-9SS
3	95.65	96.84	150	300	98.43	2.29	101.6	CF300-10CS	CF300-10SS
3	97.23	98.43	150	300	100.03	2.29	101.6	CF300-11CS	CF300-11SS
3	98.82	100.01	150	300	101.60	2.29	101.6	CF300-12CS	CF300-12SS
3	100.41	101.60	150	300	103.20	2.29	101.6	CF300-13CS	CF300-13SS
3	102.00	103.19	150	300	104.78	2.29	101.6	CF300-14CS	CF300-14SS
3	103.58	104.78	150	300	106.38	2.29	101.6	CF300-15CS	CF300-15SS
3	105.17	106.36	150	300	107.95	2.29	101.6	CF300-16CS	CF300-16SS
4	106.76	107.95	150	300	109.55	2.29	101.6	CF400-1CS	CF400-1SS
4	108.35	109.54	150	300	111.13	2.29	101.6	CF400-2CS	CF400-2SS
4	109.93	111.13	150	300	112.73	2.29	101.6	CF400-3CS	CF400-3SS
4	111.52	112.71	150	300	114.30	2.29	101.6	CF400-4CS	CF400-4SS
4	113.11	114.30	150	300	115.90	2.29	101.6	CF400-5CS	CF400-5SS
4	114.70	115.89	150	300	117.48	2.29	101.6	CF400-6CS	CF400-6SS
4	116.28	117.48	150	300	119.08	2.29	101.6	CF400-7CS	CF400-7SS
4	117.87	119.06	150	300	120.65	2.29	101.6	CF400-8CS	CF400-8SS
4	119.46	120.65	150	300	122.25	2.29	101.6	CF400-9CS	CF400-9SS
4	121.05	122.24	150	300	123.80	2.29	101.6	CF400-10CS	CF400-10SS
4	122.63	123.83	150	300	125.43	2.29	101.6	CF400-11CS	CF400-11SS
4	124.22	125.41	150	300	127.00	2.29	101.6	CF400-12CS	CF400-12SS
4	125.81	127.00	150	300	128.60	2.29	101.6	CF400-13CS	CF400-13SS
4	127.40	128.59	150	300	130.18	2.29	101.6	CF400-14CS	CF400-14SS
4	128.98	130.18	150	300	131.78	2.29	101.6	CF400-15CS	CF400-15SS
4	130.57	131.76	150	300	133.35	2.29	101.6	CF400-16CS	CF400-16SS
6	157.56	163.51	*	*	165.10	3.05	149.0	CF600-1CS	CF600-1SS
6	163.91	166.69	*	*	168.28	3.05	149.0	CF600-2CS	CF600-2SS
6	167.08	169.86	*	*	171.45	3.05	149.0	CF600-3CS	CF600-3SS
6	170.26	173.04	*	*	174.63	3.05	149.0	CF600-4CS	CF600-4SS
6	173.43	176.21	*	*	177.80	3.05	149.0	CF600-5CS	CF600-5SS
6	176.61	179.39	*	*	180.98	3.05	149.0	CF600-6CS	CF600-6SS
6	179.78	182.56	*	*	184.15	3.05	149.0	CF600-7CS	CF600-7SS
6	182.96	185.74	*	*	187.33	3.05	149.0	CF600-8CS	CF600-8SS
6	186.13	188.91	*	*	190.50	3.05	149.0	CF600-9CS	CF600-9SS

\* Consult Dixon™ for pressure rating

<sup>1</sup> Based on using crimp cam & groove shanks

<sup>2</sup> Based on using King™ combination nipples

## King Crimp™ Style Heavy-Duty Ferrules



Hose ID (inch)	Hose OD (mm)		Ferrule ID (mm)	Ferrule Wall Thickness (mm)	Ferrule Overall Length (mm)	Carbon Steel - Heavy Duty (HD)
	From	To				Part No.
4	114.70	115.90	117.48	3.05	101.60	CF400-6CSHD
4	116.30	117.50	119.08	3.05	101.60	CF400-7CSHD
4	117.90	119.10	120.65	3.05	101.60	CF400-8CSHD
4	119.50	121.70	122.25	3.05	101.60	CF400-9CSHD
4	121.00	122.25	123.83	3.05	101.60	CF400-10CSHD
4	122.60	123.85	125.43	3.05	101.60	CF400-11CSHD
4	124.20	125.40	127.00	3.05	101.60	CF400-12CSHD
4	125.80	127.00	128.60	3.05	101.60	CF400-13CSHD
4	124.40	128.60	130.18	3.05	101.60	CF400-14CSHD
4	129.00	130.20	131.78	3.05	101.60	CF400-15CSHD
4	130.60	131.80	133.35	3.05	101.60	CF400-16CSHD

**Features:**

- 400 PSI working pressure with a minimum 4:1 safety factor (hose burst: hose working pressure) is only achieved with Dixon™ carbon steel ferrule part numbers CF400-6CSHD through CF400-16CSHD.

## Crimp Style King™ Combination Nipples



Features:			Threaded End
Hose ID (inch)	Schedule 80 Plated Carbon Steel		316 Stainless Steel
	Part No.		Part No.
NPT			
1	STC10CS	RST10CS	
1¼	STC15CS	RST15CS	
1½	STC20CS	RST20CS	
2	STC25CS	RST25CS	
3	STC35CS	RST35CS	
4	STC40CS	RST40CS	
6	STC60CS	RST60CS	
BSP			
1	STC10CSA	RST10CSA	
1¼	STC15CSA	RST15CSA	
1½	STC20CSA	RST20CSA	
2	STC25CSA	RST25CSA	
3	STC35CSA	RST35CSA	
4	STC40CSA	RST40CSA	
6	STC60CSA	RST60CSA	

**Features:**

- There are two grooves on the crimp style King™ combination nipples. The second groove is the roll stamp groove, which has the part number and "call Dixon™" stamped on it. This groove is a smooth concentric groove so that the stamp can be legible.

## King Crimp™ Style Combination Nipple - Heavy Duty



Applications:		Part No.
Features:		
<p><b>Applications:</b></p> <ul style="list-style-type: none"> <li>• Used in the fast-paced transfer of water, chemicals, and sand slurry to a hydraulic fracturing site</li> </ul>		
<p><b>Features:</b></p> <ul style="list-style-type: none"> <li>• Water and petroleum transfer hoses rated from 100 to 300 PSI WP (4:1 SF) have excellent test results with the standard King Crimp™ ferrules CF400-xxCS</li> <li>• 400 PSI working pressure at 21°C (70°F) when used with heavy-duty crimp ferrules (CF400-6CSHD through CF400-16CSHD)</li> <li>• Used with ferrules above</li> </ul>		
Threaded End		
Hose ID (inch)	Schedule 80 Steel	
	Part No.	
Male NPT		
4	STC40CSHD	

**Applications:**

- Used in the fast-paced transfer of water, chemicals, and sand slurry to a hydraulic fracturing site

**Features:**

- Water and petroleum transfer hoses rated from 100 to 300 PSI WP (4:1 SF) have excellent test results with the standard King Crimp™ ferrules CF400-xxCS
- 400 PSI working pressure at 21°C (70°F) when used with heavy-duty crimp ferrules (CF400-6CSHD through CF400-16CSHD)
- Used with ferrules above



- Only use the crimp style shanks with the crimp style sleeves and ferrules.
- Due to differences in dimensions and tolerances for safety reasons, DO NOT interchange other manufacturers' products with Dixon™ products.



## Crimp Style King™ Combination Nipples

**Features:**

- There are two grooves on the crimp style King™ combination nipples. The second groove is the roll stamp groove, which has the part number and "call Dixon™" stamped on it. This groove is a smooth concentric groove so that the stamp can be legible.

**Grooved End**

Hose ID (inch)	Schedule 80 Plated Carbon Steel	316 Stainless Steel
	Part No.	Part No.
1	STV10CS	RSTV10CS
1½	STV20CS	RSTV20CS
2	STV25CS	RSTV25CS
3	STV35CS	RSTV35CS
4	STV40CS	RSTV40CS
6	STV60CS	RSTV60CS

**Bevelled End**

Hose ID (inch)	Schedule 80 Plated Carbon Steel	316 Stainless Steel
	Part No.	Part No.
1	STB10CS	RSTB10CS
1½	STB20CS	RSTB20CS
2	STB25CS	RSTB25CS
3	STB35CS	RSTB35CS
4	STB40CS	RSTB40CS
6	STB60CS	RSTB60CS

**Shouldered End**

Hose ID (inch)	Schedule 80 Plated Carbon Steel	
	Part No.	
3	STVS35CS	
4	STVS40CS	
6	STVS60CS	

**150# ASA Fixed (Welded) Flanges**

Hose ID (inch)	Steel	316 Stainless Steel
	Part No.	Part No.
1½	FST20CS	RFST20CS
2	FST25CS	RFST25CS
3	FST35CS	RFST35CS
4	FST40CS	RFST40CS
6	FST60CS	RFST60CS

Note: Other flanges available upon request.

**Floating Flanges**

Hose ID (inch)	Plated Carbon Steel	316 Stainless Steel
	Part No.	Part No.
2	N25CS	RN25CS
3	N35CS	RN35CS
4	N40CS	RN40CS
6	N60CS	RN60CS



 Only use the crimp style shanks with the crimp style sleeves and ferrules.  
 • Due to differences in dimensions and tolerances for safety reasons, DO NOT interchange other manufacturers' products with Dixon™ products.

## King Crimp™ Style Nipple - NPT Threaded End



Size (inch)	Schedule 40 Plated Carbon Steel	
	Part No.	
8	STC80CS	

B

## King Crimp™ Style Nipple - Grooved End



Size (inch)	Schedule 40 Plated Carbon Steel	
	Part No.	
8	STV80CS	

## King Crimp™ Style Short Frac Ferrules

### Features:

- Schedule 40 plated carbon steel to ASTM standards
- Consult Dixon™ for additional ferrule sizes



Hose ID (inch)	Hose OD (mm)		Ferrule ID (mm)	Ferrule Wall Thickness (mm)	Ferrule Overall Length (mm)	Carbon Steel
	From	To				Part No.
8	214.70	217.50	219.10	3.05	108	CFS800-1CS
8	217.90	220.65	225.25	3.05	108	CFS800-2CS
8	221.00	223.90	225.40	3.05	108	CFS800-3CS
8	224.00	227.00	228.60	3.05	108	CFS800-4CS
8	227.40	230.20	231.80	3.05	108	CFS800-5CS
8	230.60	233.30	234.95	3.05	108	CFS800-6CS
8	233.70	236.50	238.15	3.05	108	CFS800-7CS
8	236.90	239.70	241.30	3.05	108	CFS800-8CS

## King Crimp™ Style Sleeves



Hose ID (inch)	Sleeve ID (mm)	Sleeve Wall Thickness (mm)	Sleeve Overall Length (mm)	Carbon Steel
				Part No.
8	210.80	3.05	222.20	S830X875X120CS
8	212.85	3.05	152.40	S838X600X120CS
8	215.90	3.05	165.10	S850X650X120CS
8	222.95	3.05	152.40	S875X600X120CS
8	228.10	3.05	222.20	S898X875X120CS
8	228.60	2.30	101.60	S900X400X090CS
8	228.60	3.05	101.60	S900X400X120CS
8	228.60	3.05	152.40	S900X600X120CS
8	231.15	3.05	101.60	S910X400X120CS
8	231.65	3.05	152.40	S912X600X120CS
8	232.40	3.05	152.40	S915X600X120CS
8	234.95	3.05	152.40	S925X600X120CS
8	234.95	3.05	101.60	S925X400X120CS
8	241.30	3.05	101.60	S950X400X120CS
8	241.30	3.05	152.40	S950X600X120CS
8	247.65	3.05	152.40	S975X600X120CS
10	260.35	3.05	190.50	S1025X750X120CS
10	266.70	3.05	190.50	S1050X750X120CS
10	279.40	3.05	152.40	S1100X600X120CS
10	298.65	3.05	152.40	S1175X600X120CS

## King Crimp™ Working Pressure Chart

Size (inch)	Temperature	Fitting	Clamps	Working Pressure PSIG	Size (inch)	Temperature	Fitting	Clamps	Working Pressure PSIG
1	Ambient	STC10CS	sleeve	400	3	Ambient	STC35CS	sleeve	200
	71°C	STC10CS	sleeve	270		71°C	STC35CS	sleeve	140
	82°C	STC10CS	sleeve	250		82°C	STC35CS	sleeve	100
	121°C	STC10CS	sleeve	200		121°C	STC35CS	sleeve	75
	Ambient	STC10CS	ferrule	400		Ambient	STC35CS	ferrule	300
	71°C	STC10CS	ferrule	270		71°C	STC35CS	ferrule	218
	82°C	STC10CS	ferrule	250		82°C	STC35CS	ferrule	200
	121°C	STC10CS	ferrule	200		121°C	STC35CS	ferrule	100
	Ambient	100-C/E	sleeve	250		Ambient	300-C/E	sleeve	125
	71°C	100-C/E	sleeve	242		71°C	300-C/E	sleeve	100
	82°C	100-C/E	sleeve	240		82°C	300-C/E	sleeve	60
	121°C	100-C/E	sleeve	200		121°C	300-C/E	sleeve	55
	Ambient	100-C/E	ferrule	250		Ambient	300-C/E	ferrule	150
	71°C	100-C/E	ferrule	242		71°C	300-C/E	ferrule	125
	82°C	100-C/E	ferrule	240		82°C	300-C/E	ferrule	100
	121°C	100-C/E	ferrule	200		121°C	300-C/E	ferrule	75
1 1/2	Ambient	STC20CS	sleeve	300	4	Ambient	STC40CS	sleeve	175
	71°C	STC20CS	sleeve	225		71°C	STC40CS	sleeve	100
	82°C	STC20CS	sleeve	200		82°C	STC40CS	sleeve	100
	121°C	STC20CS	sleeve	100		121°C	STC40CS	sleeve	50
	Ambient	STC20CS	ferrule	350		Ambient	STC40CS	ferrule	300
	71°C	STC20CS	ferrule	225		71°C	STC40CS	ferrule	218
	82°C	STC20CS	ferrule	200		82°C	STC40CS	ferrule	200
	121°C	STC20CS	ferrule	150		121°C	STC40CS	ferrule	100
	Ambient	150-C/E	sleeve	250		Ambient	400-C/E	sleeve	110
	71°C	150-C/E	sleeve	200		71°C	400-C/E	sleeve	75
	82°C	150-C/E	sleeve	100		82°C	400-C/E	sleeve	60
	121°C	150-C/E	sleeve	75		121°C	400-C/E	sleeve	50
	Ambient	150-C/E	ferrule	250		Ambient	400-C/E	ferrule	150
	71°C	150-C/E	ferrule	200		71°C	400-C/E	ferrule	75
	82°C	150-C/E	ferrule	150		82°C	400-C/E	ferrule	75
	121°C	150-C/E	ferrule	100		121°C	400-C/E	ferrule	75
2	Ambient	STC25CS	sleeve	250	6	Ambient	STC60CS	sleeve	75
	71°C	STC25CS	sleeve	150		71°C	STC60CS	sleeve	---
	82°C	STC25CS	sleeve	125		82°C	STC60CS	sleeve	---
	121°C	STC25CS	sleeve	80		121°C	STC60CS	sleeve	---
	Ambient	STC25CS	ferrule	300		Ambient	STC60CS	ferrule	230
	71°C	STC25CS	ferrule	239		71°C	STC60CS	ferrule	---
	82°C	STC25CS	ferrule	225		82°C	STC60CS	ferrule	---
	121°C	STC25CS	ferrule	100		121°C	STC60CS	ferrule	---
	Ambient	200-C/E	sleeve	250		Ambient	600-C/E	sleeve	75
	71°C	200-C/E	sleeve	100		71°C	600-C/E	sleeve	---
	82°C	200-C/E	sleeve	50		82°C	600-C/E	sleeve	---
	121°C	200-C/E	sleeve	50		121°C	600-C/E	sleeve	---
	Ambient	200-C/E	ferrule	250		Ambient	600-C/E	ferrule	75
	71°C	200-C/E	ferrule	100		71°C	600-C/E	ferrule	---
	82°C	200-C/E	ferrule	100		82°C	600-C/E	ferrule	---
	121°C	200-C/E	ferrule	100		121°C	600-C/E	ferrule	---

B

## Holedall™ External Swage Coupling System

The Holedall™ system is a method of attaching couplings to hose utilizing a progressive swage. The patented Holedall™ couplings include a Holedall™ stem and a specially engineered ferrule. The hydraulic swaging of the coupling to the hose is accomplished by pushing the ferrule through a die which reduces the ferrule OD, thus providing a 360° uninterrupted compression band around the hose.

This multi-purpose, high-pressure coupling system requires no bolts and results in a clean coupling with no protrusions. The swaging operation is fast and hose of various lengths and different styles can be coupled. Ease of operation, flexibility, and economy make the Holedall™ method an unequalled assembly system.

The Holedall™ coupling:

- Provides long-lasting efficiency and safety
- Lightweight coupling consisting of ferrule and stem
- Streamlined; no protrusions to snag on equipment
- Available in stainless steel and carbon steel
- Available in multiple configurations: pipe thread, plain end, grooved, or flanged ends



Dixon™ Holedall™ stems and ferrules are specifically designed to be used together as a coupling system. Due to differences in dimensions and tolerances, for safety reasons, do not use other manufacturers' stems or ferrules with Dixon™ Holedall™ products.



**Note:** Do not use wrench or vice on ferrule

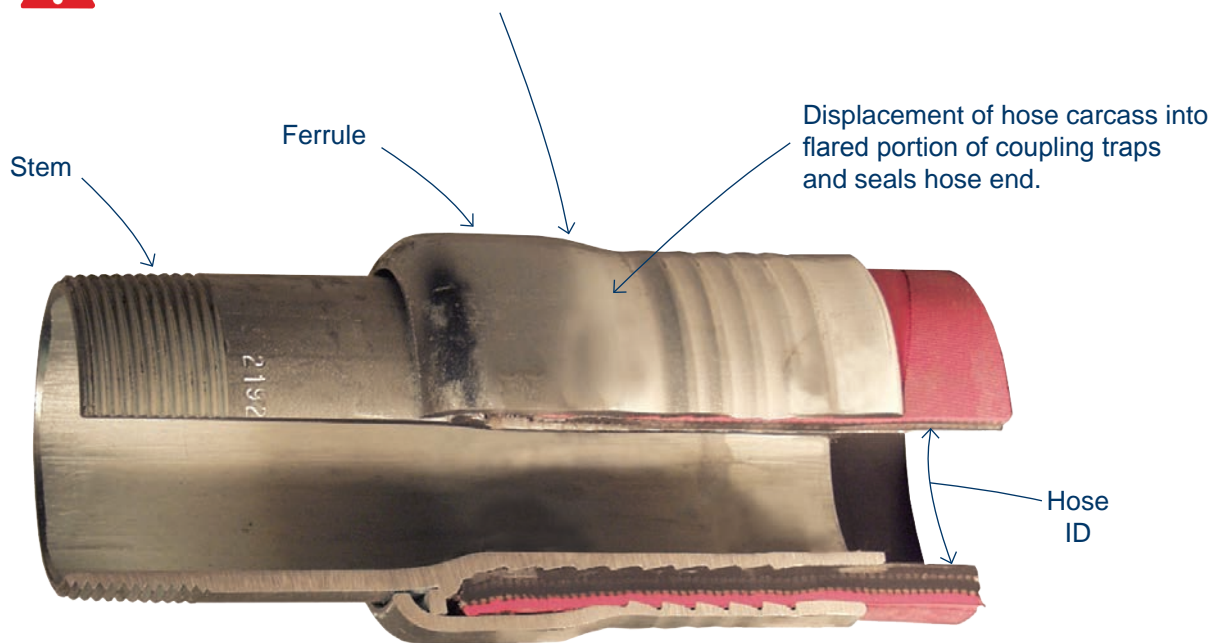

Cross-section of Holedall™ externally swaged assembly

## External Swage Stems

Plain End Stem for Welding - Natural Finish

Nominal Bore (inch)	Carbon Steel Part No.	Stainless Steel Part No.
2	HA0074	HA1074
2½	HA0075	HA1075
3	HA0076	HA1076
4	HA0077	HA1077
5	HA0078	HA1078
6	HA0079	HA1079
8	HA0100	HA1100

Note: Plain end stems are usually manufactured in carbon steel: ASTM A106 grade A/B or API 5L grade A/B, and stainless steel: BS970: 1983 grade 316 S11.



B

Male Thread Stem - Yellow Zinc Plated

Nominal Bore (inch)	Carbon Steel			Stainless Steel		
	BSP Part No.	BSPT Part No.	API / NPT Part No.	BSP Part No.	BSPT Part No.	API / NPT Part No.
32	HA0081ZP	HA0081TZP	HA0082ZP	HA1081	HA1081T	HA1082
40	HA0084ZP	HA0084TZP	HA0085ZP	HA1084	HA1084T	HA1085
50	HA0087ZP	HA0087TZP	HA0088ZP	HA1087	HA1087T	HA1088
65	HA0090ZP	HA0090TZP	HA0091ZP	HA1090	HA1090T	HA1091
75	HA0093ZP	HA0093TZP	HA0094ZP	HA1093	HA1093T	HA1094
100	HA0096ZP	HA0096TZP	HA0097ZP	HA1096	HA1096T	HA1097
125	HA0146ZP	HA0146TZP	HA0147ZP	HA1146	HA1146T	HA1147

Note: Threaded end stems are usually manufactured in carbon steel: ASTM A106 grade A/B or API 5L grade A/B, and stainless steel: BS970: 1983 grade 316 S11.



Victaulic Groove Stem - Yellow Zinc Plated

Nominal Bore (inch)	Carbon Steel Part No.	Stainless Steel Part No.
2	HA0083ZP	HA1083
2½	HA0086ZP	HA1086
3	HA0089ZP	HA1089
4	HA0092ZP	HA1092
5	HA0095ZP	HA1095
6	HA0098ZP	HA1098
8	HA0149ZP	HA1149

Note: Victaulic groove stems are usually manufactured in carbon steel: ASTM A106 grade A/B or API 5L grade A/B, and stainless steel: BS970: 1983 grade 316 S11.

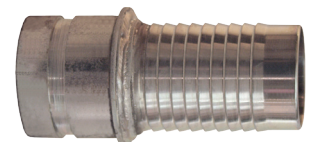

Flanged Stem Fixed & Swivel - Yellow Zinc Plated

Nominal Bore (inch)	Carbon Steel		Stainless Steel	
	Fixed Part No.	Swivel Part No.	Fixed Part No.	Swivel Part No.
2	HA0172ZP	HA0157ZP	HA1172	HA1157
2½	HA0173ZP	HA0158ZP	HA1173	HA1158
3	HA0174ZP	HA0159ZP	HA1174	HA1159
4	HA0175ZP	HA0160ZP	HA1175	HA1160
5	HA0176ZP	HA0161ZP	HA1176	HA1161
6	HA0177ZP	HA0162ZP	HA1177	HA1162
8	HA0178ZP	HA0163ZP	HA1178	HA1163

Note: Couplings are also available for metric sized hose bores.

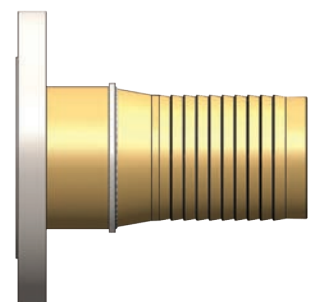

## Holedal™ External Swage (ES) Ferrule Selection Chart (Standard 20 Bar Hose)

B

Internal Expansion Ferrule Selection Guide										
Wall Thk. (mm)	Hose Bore Size (Standard Inch Sizing)									
	1"	1¼"	1½"	2"	2½"	3"	4"	5"	6"	8"
4										
4½										
5										
5½										
6	44.5-2.5	51-2.5	58-3	71-3	84-3	97-3				
6½	45.5-2.5	52-2.5	59-3	72-3	85-3	98-3				
7	46.5-2.5	53-2.5	60-3	73-3	86-3	99-3	125-3	152-4		
7½		54-2.5	61-3	74-3	87-3	100-3	126-3	153-4		
8		55-2.5	62-3	75-3	88-3	101-3	127-3	154-4		
8½		56-2.5	63-3	76-3	89-3	102-3	128-3	155-4		
9		57-2.5	64-3	77-3	90-3	103-3	129-3	156-4	182-4.5	
9½		58-2.5	65-3	78-3	91-3	104-3	130-3	157-4	183-4.5	
10		59-2.5	66-3	79-3	92-3	105-3	131-3	158-4	184-4.5	236-5
10½				80-3	93-3	106-3	132-3	159-4	185-4.5	237-5
11				81-3	94-3	107-3	133-3	160-4	186-4.5	238-5
11½				82-3	94-3	108-3	134-3	161-4	187-4.5	239-5
12				83-3	95-3	109-3	135-3	162-4	188-4.5	240-5
12½				84-3	96-3	110-3	136-3	163-4	189-4.5	241-5
13							137-3	164-4	190-4.5	242-5
13½							138-3	165-4	191-4.5	243-5
14							139-3	166-4	192-4.5	244-5
14½							140-3	167-4	193-4.5	245-5
15							141-3	168-4	194-4.5	246-5
15½								169-4	195-4.5	247-5
16								170-4	196-4.5	248-5
16½								171-4	197-4.5	249-5
17									198-4.5	250-5
17½										251-5
18										252-5
18½										253-5
19										254-5
19½										255-5
20										256-5

Carbon steel ferrules are supplied yellow zinc plated and passivated in accordance with BS1706:1990 with the part numbers ending in ZP. Stainless steel ferrules are supplied in grade 304/304L and are natural finish.

### Ferrule coding example:

4" Hose x 10mm wall thickness. The prefix is HA0071 from the carbon steel table. The ferrule coding for a 10mm wall thickness hose is 131-3 from the table above. The complete part number is HA0072-131-3ZP.



Victaulic Groove Stem - Yellow Zinc Plated		
Nominal Bore (inch)	Carbon Steel Part No.	Stainless Steel Part No.
2	HA0068	HA1068
2½	HA0069	HA1069
3	HA0070	HA1070
4	HA0071	HA1071
5	HA0072	HA1072
6	HA0073	HA1073
8	HA0188	HA1188

## Dixon™ Hookie Hook External Crimp Hose Stem

<b>Material:</b>	• Carbon Steel
------------------	----------------

Size (inch)	Part No.
3	HA0197ZP
4	HA0198ZP
5	HA0199ZP



## Dixon™ Hookie Hook Lifter

<b>Application:</b>	• Predominantly used for bulk loading/rig supply hose operations on offshore applications
<b>Material:</b>	• Forged carbon steel, yellow zinc plated per BS1706
<b>Options:</b>	• With or without retaining clamp
<b>Load Rating:</b>	• Safe working load 4 tons with a proof load test of 8 tons

Size (inch)	Part No.
3	HA0900-3
4	HA0900-4
5	HA0900-5



Internal swage ferrules can be supplied in either, natural, yellow zinc plated, or powder coat painted finishes in accordance with UKOOA (United Kingdom Offshore Operators Association) colour coding scheme or to suit specific requirements.

Ferrule Colour Coding	
Ferrule Colour Code	Hose Application
Yellow	Dry Cement
Orange	Dry Baryte
Blue	Potable Water
Brown	Diesel Oil/Fuel
Red	Base Oil/ Brine
Green	Drill Water
Black	Oil Based Mud
Purple	Glycol
Pink (Black/Brown Strip)	Base Oil/Fuel Oil
No Colour	Scale Inhibitor

Note: External swage or crimp ferrules are usually supplied in yellow zinc plated finish.

## Holedall™ External Crimp Coupling System

The Holedall™ system is a method of attaching couplings to hose utilizing a progressive swage. The patented Holedall™ couplings include a Holedall™ stem and a specially engineered ferrule. The hydraulic swaging of the coupling to the hose is accomplished by pushing the ferrule through a die which reduces the ferrule OD, thus providing a 360° uninterrupted compression band around the hose.

This multi-purpose, high pressure coupling system requires no bolts and results in a clean coupling with no protrusions. The swaging operation is fast and hose of various lengths and different styles can be coupled. Ease of operation, flexibility and economy make the Holedall™ method an unequalled assembly system.

The Holedall™ coupling:

- Provides long-lasting efficiency and safety
- Lightweight coupling consisting of ferrule and stem
- Streamlined; no protrusions to snag on equipment
- Available in stainless steel and carbon steel
- Available in multiple configurations: pipe thread, plain end, grooved, or flanged ends



Dixon™ Holedall™ stems and ferrules are specifically designed to be used together as a coupling system. Due to differences in dimensions and tolerances, for safety reasons, do not use other manufacturers' stems or ferrules with Dixon™ Holedall™ products.



**Note:** Do Not Use Wrench or Vice on Ferrule

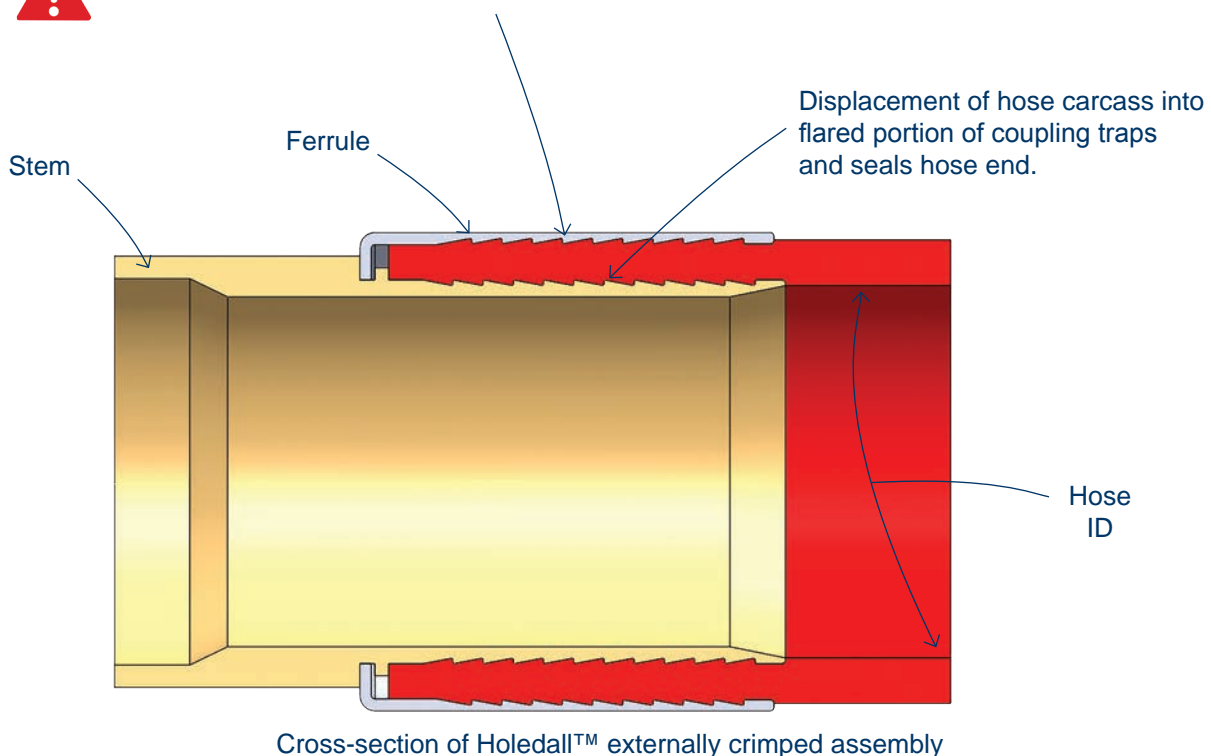



## External Crimp Stems

Plain End Stem for Welding - Natural Finish

Nominal Bore (inch)	Carbon Steel Part No.	Stainless Steel Part No.
¾	HA0101	HA1101
1	HA0102	HA1102
1¼	HA0103	HA1103
1½	HA0104	HA1104
2	HA0105	HA1105
2½	HA0106	HA1106
3	HA0107	HA1107
4	HA0108	HA1108

Note: Plain end stems are usually manufactured in carbon steel: ASTM A106 grade A/B or API 5L grade A/B, and stainless steel: BS970: 1983 grade 316 S11.



Male Thread Stem - Yellow Zinc Plated

Nominal Bore (inch)	Carbon Steel			Stainless Steel		
	BSP Part No.	BSPT Part No.	API / NPT Part No.	BSP Part No.	BSPT Part No.	API / NPT Part No.
¾	HA0109ZP	HA0109TZP	HA0117ZP	HA1109	HA1109T	HA1117
1	HA0110ZP	HA0110TZP	HA0118ZP	HA1110	HA1110T	HA1118
1¼	HA0111ZP	HA0111TZP	HA0119ZP	HA1111	HA1111T	HA1119
1½	HA0112ZP	HA0112TZP	HA0120ZP	HA1112	HA1112T	HA1120
2	HA0113ZP	HA0113TZP	HA0121ZP	HA1113	HA1113T	HA1121
2½	HA0114ZP	HA0114TZP	HA0122ZP	HA1114	HA1114T	HA1122
3	HA0116ZP	HA0115TZP	HA0123ZP	HA1115	HA1115T	HA1123
4	HA0116ZP	HA0116TZP	HA0124ZP	HA1116	HA1116T	HA1124

Note: Threaded end stems are usually manufactured in carbon steel: ASTM A106 grade A/B or API 5L grade A/B, and stainless steel: BS970: 1983 grade 316 S11.



Victaulic Groove Stem - Yellow Zinc Plated

Nominal Bore (inch)	Carbon Steel Part No.	Stainless Steel Part No.
¾	HA0125ZP	HA1125
1	HA0126ZP	HA1126
1¼	HA0127ZP	HA1127
1½	HA0128ZP	HA1128
2	HA0129ZP	HA1129
2½	HA0130ZP	HA1130
3	HA0131ZP	HA1131
4	HA0132ZP	HA1132

Note: Victaulic groove stems are usually manufactured in carbon steel: ASTM A106 grade A/B or API 5L grade A/B, and stainless steel: BS970: 1983 grade 316 S11.



Flanged Stem Fixed & Swivel - Yellow Zinc Plated

Nominal Bore (inch)	Carbon Steel		Stainless Steel	
	Fixed Part No.	Swivel Part No.	Fixed Part No.	Swivel Part No.
¾	HA0179ZP	HA0164ZP	HA1179	HA1164
1	HA0180ZP	HA0165ZP	HA1180	HA1165
1¼	HA0181ZP	HA0166ZP	HA1181	HA1166
1½	HA0182ZP	HA0167ZP	HA1182	HA1167
2	HA0183ZP	HA0168ZP	HA1183	HA1168
2½	HA0184ZP	HA0169ZP	HA1184	HA1169
3	HA0185ZP	HA0170ZP	HA1185	HA1170
4	HA0186ZP	HA0171ZP	HA1186	HA1171

Note: Flanged stems are usually manufactured in carbon steel: ASTM A106 grade A/B or API 5L grade A/B, and stainless steel: BS970:1983 grade 316 S11. Flange materials: carbon steel (ASTM A105N); stainless steel (ASTM A182 grade 316L). Both fixed (slip-on-weld) and loose (swivel) flanged stems are available with flanges in accordance with ASME/ANSI B16.5 class 150/300 lb, BS4504 PN10/16, BS10 Tables D-H. Couplings are also available for metric sized hose bores.

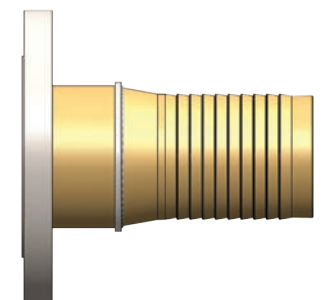

## Holedal™ Internal Crimp (EC) Ferrule Selection Chart (Standard 20 Bar Hose)

Internal Expansion Ferrule Selection Guide									
Wall Thk. (mm)	Hose Bore Size (Standard Inch Sizing)								
	1"	1¼"	1½"	2"	2½"	3"	4"	5"	6"
4	40.5-2.5	47-2.5							
4½	41.5-2.5	48-2.5							
5	42.5-2.5	49-2.5	56-3						
5½	43.5-2.5	50-2.5	57-3						
6	44.5-2.5	51-2.5	58-3	71-3	84-3	97-3			
6½	45.5-2.5	52-2.5	59-3	72-3	85-3	98-3			
7	46.5-2.5	53-2.5	60-3	73-3	86-3	99-3	125-3	152-4	
7½		54-2.5	61-3	74-3	87-3	100-3	126-3	153-4	
8		55-2.5	62-3	75-3	88-3	101-3	127-3	154-4	
8½		56-2.5	63-3	76-3	89-3	102-3	128-3	155-4	
9		57-2.5	64-3	77-3	90-3	103-3	129-3	156-4	182-4.5
9½		58-2.5	65-3	78-3	91-3	104-3	130-3	157-4	183-4.5
10		59-2.5	66-3	79-3	92-3	105-3	131-3	158-4	184-4.5
10½				80-3	93-3	106-3	132-3	159-4	185-4.5
11				81-3	94-3	107-3	133-3	160-4	186-4.5
11½				82-3	94-3	108-3	134-3	161-4	187-4.5
12				83-3	95-3	109-3	135-3	162-4	188-4.5
12½				84-3	96-3	110-3	136-3	163-4	189-4.5
13							137-3	164-4	190-4.5
13½							138-3	165-4	191-4.5
14							139-3	166-4	192-4.5
14½							140-3	167-4	193-4.5
15							141-3	168-4	194-4.5
15½								169-4	195-4.5
16								170-4	196-4.5
16½								171-4	197-4.5
17									198-4.5

Carbon steel ferrules are supplied yellow zinc plated and passivated in accordance with BS1706:1990 with the part numbers ending in ZP. Stainless steel ferrules are supplied in grade 304/304L and are natural finish.

### Ferrule coding example:

4" hose x 10mm wall thickness. The prefix is HA0196 from table below. The ferrule coding for a 10mm wall thickness hose is 131-3 from the table above. The complete part number is HA0072-131-3ZP.



Victaulic Groove Stem - Yellow Zinc Plated		
Nominal Bore (inch)	Carbon Steel Part No.	Stainless Steel Part No.
1	HA0190	HA1190
1¼	HA0191	HA1191
1½	HA0192	HA1192
2	HA0193	HA1193
2½	HA0194	HA1194
3	HA0195	HA1195
4	HA0196	HA1196
5	HA0417	HA1417
6	HA0418	HA1418

## Holedal™ Uni-Range External Couplings

Designed for smaller hose systems, these couplings may be used for hose IDs of 6mm - 25mm and come complete with factory assembled stem and ferrule combination. Can be used with swage or crimp equipment.

Plated Carbon Steel Stem, Ferrule			
ID & NPTF Size (mm)	Hose OD (mm)		Part No.
	From:	To:	
6	13	15	4P1
6	15	17	4P2
6	17	18	4P3
10	18	20	6P1
10	20	21	6P2
10	21	23	6P3
15	21	23	8P1
15	23	25	8P2
15	25	30	8P3
20	29	31	12P1
20	31	32	12P2
20	32	37	12P3
25	37	39	16P1
25	39	40	16P2
25	40	42	16P3
25	42	44	16P4

Other sizes available on special order.



## Holedal™ High Pressure Couplings

<b>Application:</b>	<ul style="list-style-type: none"> <li>Intended for services requiring a fitting to withstand extremely high pressures (up to <b>3,000 PSI</b> at <b>21°C (70°F)</b>) and severe operating conditions including: small and medium size drilling rigs, slim hole applications and core drill, workover, seismograph, water well, blast or shot holes.</li> </ul>
<b>Features:</b>	<ul style="list-style-type: none"> <li>Sold as a complete coupling (stem and matching ferrule)</li> <li>Must provide hose OD when ordering for a properly sized ferrule; make sure both ends of the hose are measured for OD</li> <li>Must be swaged with 50 ton or 100 ton ram</li> <li>API and NPT sizes are interchangeable</li> <li>Stems are machined from seamless pipe and tubing with specially designed serrations</li> <li>Ferrules are machined from a heavy wall material incorporating matching serrations</li> </ul>

Zinc Plated Steel Stem / Ferrule Assemblies	
ID & NPT Size (mm)	Part No.
50	LM32-*
65	LM40-*
75	LM48-*



\* The LM fitting is sold as a complete coupling including stem and ferrule. Accurate hose OD must be provided to complete the part number and to ensure proper retention.

# Industrial Hose Fittings

## Holedall™ Internal Expansion Couplings

### Applications:

- Essential in applications requiring maximum flow including: concrete pump hose, plaster and grout hose, oil suction and discharge hose, multi-purpose heavy-duty air hose, jetting hose, barge loading hose, and bottom loading hose.

### Features:

- Maximum flow of media
- Reduction of turbulence through hose
- Excellent sealing and retention characteristics
- Outperforms band clamps
- Easy and consistent installation
- Only one expansion tool is needed for each hose ID
- Available end configurations: male NPT, raised end (California style), grooved, others available (contact Dixon™)



Dixon™ Holedall™ stems and ferrules are specifically designed to be used together as a coupling system. Due to differences in dimensions and tolerances, for safety reasons, do not use other manufacturers' stems or ferrules with Dixon™ Holedall™ products.

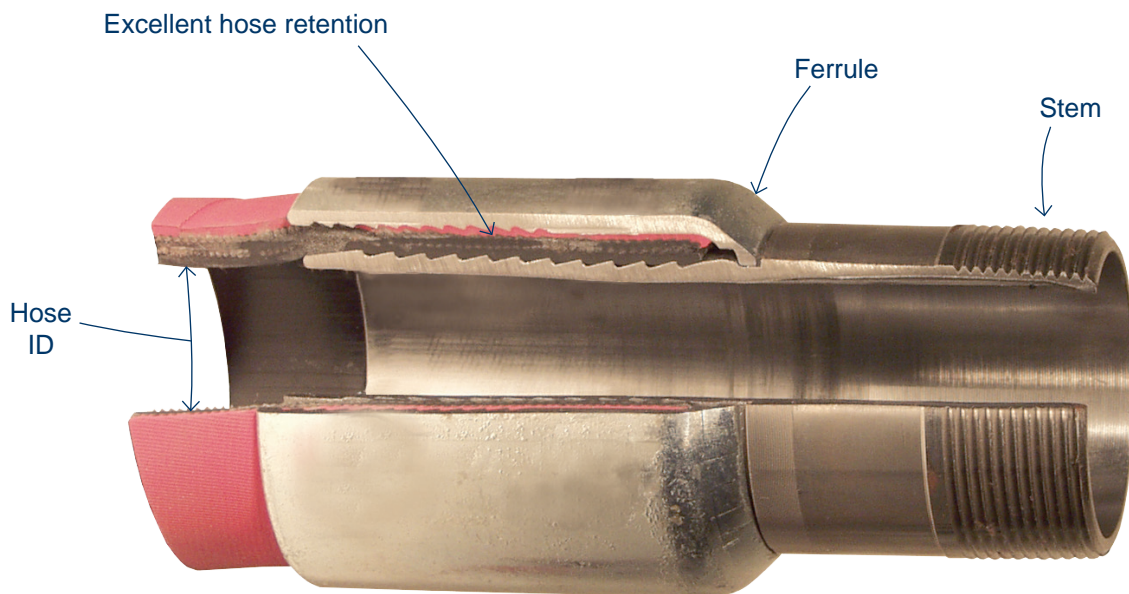

Cross-section of Holedall™ internally expanded assembly

## Internal Expansion Stems

Plain End Stem for Welding - Natural Finish

Nominal Bore (inch)	Carbon Steel Part No.	Stainless Steel Part No.
2	HA0050	HA1050
2½	HA0037	HA1037
3	HA0032	HA1032
4	HA0029	HA1029
5	HA0054	HA1054
6	HA0058	HA1058
8	HA0099	HA1099
10	HA0369	---
12	HA0370	---

Note: Plain end stems are usually manufactured in carbon steel: ASTM A106 grade A/B or API 5L grade A/B, and stainless steel: BS970: 1983 grade 316 S11.



Male Thread Stem - Yellow Zinc Plated

Nominal Bore (inch)	Carbon Steel			Stainless Steel		
	BSP Part No.	BSPT Part No.	API / NPT Part No.	BSP Part No.	BSPT Part No.	API / NPT Part No.
2	HA0051ZP	HA0051TZP	HA0052ZP	HA1051	HA1051T	HA1052
2½	HA0038ZP	HA0038TZP	HA0039ZP	HA1038	HA1038T	HA1039
3	HA0033ZP	HA0033TZP	HA0034ZP	HA1033	HA1033T	HA1034
4	HA0031ZP	HA0031TZP	HA0026ZP	HA1031	HA1031T	HA1026
5	HA0055ZP	HA0055TZP	HA0056ZP	HA1055	HA1055T	HA1056
6	HA0059ZP	HA0059TZP	HA0060ZP	HA1059	HA1059T	HA1060
8	HA0144ZP	HA0144TZP	HA0145ZP	HA1144	HA1144T	HA1145
10	---	HA0371TZP	---	---	---	---
12	---	HA0372TZP	---	---	---	---

Note: Threaded end stems are usually manufactured in carbon steel: ASTM A106 grade A/B or API 5L grade A/B, and stainless steel: BS970: 1983 grade 316 S11



Victaulic Groove Stem - Yellow Zinc Plated

Nominal Bore (inch)	Carbon Steel Part No.	Stainless Steel Part No.
2	HA0053ZP	HA1053
2½	HA0040ZP	HA1040
3	HA0035ZP	HA1035
4	HA0030ZP	HA1030
5	HA0057ZP	HA1057
6	HA0061ZP	HA1061
8	HA0148ZP	HA1148

Note: Victaulic groove stems are usually manufactured in carbon steel: ASTM A106 grade A/B or API 5L grade A/B, and stainless steel: BS970: 1983 grade 316 S11.

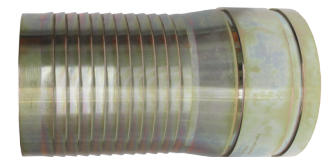

Flanged Stem Fixed & Swivel - Yellow Zinc Plated

Nominal Bore (inch)	Carbon Steel		Stainless Steel	
	Fixed Part No.	Swivel Part No.	Fixed Part No.	Swivel Part No.
2	HA0134ZP	HA0150ZP	HA1134	HA1150
2½	HA0135ZP	HA0151ZP	HA1135	HA1151
3	HA0136ZP	HA0152ZP	HA1136	HA1152
4	HA0137ZP	HA0153ZP	HA1137	HA1153
5	HA0138ZP	HA0154ZP	HA1138	HA1154
6	HA0139ZP	HA0155ZP	HA1139	HA1155
8	HA0140ZP	HA0156ZP	HA1140	HA1156
10	HA0924ZP	HA0397ZP	---	---
12	HA0925ZP	HA0926ZP	---	---

Note: Flanged stems are usually manufactured in carbon steel: ASTM A106 grade A/B or API 5L grade A/B, and stainless steel: BS970:1983 grade 316 S11. Couplings are also available for metric sized hose bores.

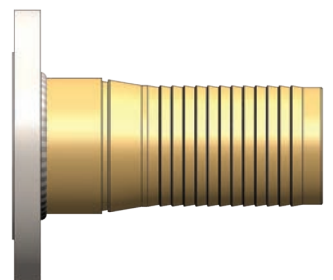

## Holedal™ Internal Expansion (IX) Ferrule Selection Chart (Standard 20 Bar Hose)

Internal Expansion Ferrule Selection Guide												
Wall Thk. (mm)	Hose Bore Size (Standard Inch Sizing)											
	1"	1¼"	1½"	2"	2½"	3"	4"	5"	6"	8"	10"	12"
4	40.5-2.5	47-2.5										
4½	41.5-2.5	48-2.5										
5	42.5-2.5	49-2.5	56-3									
5½	43.5-2.5	50-2.5	57-3									
6	44.5-2.5	51-2.5	58-3	71-3	84-3	97-3						
6½	45.5-2.5	52-2.5	59-3	72-3	85-3	98-3						
7	46.5-2.5	53-2.5	60-3	73-3	86-3	99-3	125-3	152-4				
7½		54-2.5	61-3	74-3	87-3	100-3	126-3	153-4				
8		55-2.5	62-3	75-3	88-3	101-3	127-3	154-4				
8½		56-2.5	63-3	76-3	89-3	102-3	128-3	155-4				
9		57-2.5	64-3	77-3	90-3	103-3	129-3	156-4	182-4.5			
9½		58-2.5	65-3	78-3	91-3	104-3	130-3	157-4	183-4.5			
10		59-2.5	66-3	79-3	92-3	105-3	131-3	158-4	184-4.5	236-5		
10½				80-3	93-3	106-3	132-3	159-4	185-4.5	237-5		
11				81-3	94-3	107-3	133-3	160-4	186-4.5	238-5		
11½				82-3	94-3	108-3	134-3	161-4	187-4.5	239-5		
12				83-3	95-3	109-3	135-3	162-4	188-4.5	240-5		
12½				84-3	96-3	110-3	136-3	163-4	189-4.5	241-5		
13							137-3	164-4	190-4.5	242-5	295-6	
13½							138-3	165-4	191-4.5	243-5	296-6	
14							139-3	166-4	192-4.5	244-5	297-6	
14½							140-3	167-4	193-4.5	245-5	298-6	349-6
15							141-3	168-4	194-4.5	246-5	299-6	350-6
15½								169-4	195-4.5	247-5	300-6	351-6
16								170-4	196-4.5	248-5	301-6	352-6
16½								171-4	197-4.5	249-5	302-6	353-6
17									198-4.5	250-5	303-6	354-6
17½										251-5	304-6	355-6
18										252-5	305-6	356-6
18½										253-5	306-6	357-6
19										254-5	307-6	358-6
19½										255-5	308-6	359-6
20										256-5	309-6	360-6

Carbon steel ferrules are supplied yellow zinc plated and passivated in accordance with BS1706:1990 or alternatively powder painted in accordance with the Oil & Gas UK Colour Coding Scheme which can be found on page 125. Please specify ferrule finish on your purchase order. Stainless-steel ferrules are supplied in grade 304/304L and are natural finish.

### Ferrule coding example:

4" Hose x 10mm wall thickness, for conveying base oil. The prefix is HA0065 from the table below. The ferrule coding for a 10mm wall thickness hose is 131-3 from the table above. The complete part number is HA0065-131-3RED.



Victaulic Groove Stem - Yellow Zinc Plated		
Nominal Bore (inch)	Carbon Steel Part No.	Stainless Steel Part No.
1	HA0350	HA1350
1¼	HA0789	HA1789
1½	HA0332	HA1332
2	HA0062	HA1062
2½	HA0063	HA1063
3	HA0064	HA1064
4	HA0065	HA1065
5	HA0066	HA1066
6	HA0067	HA1067
8	HA0187	HA1187
10	HA0367	HA1367
12	HA0368	HA1368

## Dixon™ Hookie Hook Internal Expansion Hose Stem

<b>Material:</b>	• Carbon Steel
------------------	----------------

Size (inch)	Part No.
3	HA0141ZP
4	HA0142ZP
5	HA0143ZP



## Internal Expansion Ferrules

<b>Material:</b>	• Plated carbon steel
<b>Features:</b>	<ul style="list-style-type: none"> <li>• Dixon™ recommends using a diameter tape for determining correct ferrule size</li> <li>• For hoses that use IXF48-3 to IXF48-5 and IXF64-2 to IXF64-5, contact Dixon™ for working pressure</li> <li>• For metric size hose, contact Dixon™ Engineering</li> </ul>



ID Size (inch)	Ferrule Size (mm)	Hose OD (mm)		Part No.
		From:	To:	
1	36.5	34.9	36.5	IXF16-1
1	38.1	36.5	38.1	IXF16-2
1	39.7	38.1	39.7	IXF16-3
1¼	42.9	41.3	42.9	IXF20-Z
1¼	44.5	42.9	44.5	IXF20-1
1¼	47.6	44.5	46.0	IXF20-2
1¼	47.6	46.0	47.6	IXF20-3
1¼	49.2	47.6	49.2	IXF20-4
1¼	50.8	49.2	50.8	IXF20-5
1¼	52.4	50.8	52.4	IXF20-6
1½	49.2	47.6	49.2	IXF24-Z
1½	50.8	49.2	50.8	IXF24-1
1½	52.4	50.8	52.4	IXF24-2
1½	54.0	52.4	54.0	IXF24-3
1½	55.6	54.0	55.6	IXF24-4
1½	57.2	55.6	57.2	IXF24-5
1½	58.7	57.2	58.7	IXF24-6
1½	60.3	58.7	60.3	IXF24-7
2	65.1	63.5	65.1	IXF32-Y
2	66.7	65.1	66.7	IXF32-Z
2	68.3	66.7	68.3	IXF32-1
2	69.9	68.3	69.9	IXF32-2
2	71.4	69.9	71.4	IXF32-3
2	73.0	71.4	73.0	IXF32-4
2	74.6	73.0	74.6	IXF32-5
2	76.2	74.6	76.2	IXF32-6
2	77.8	76.2	77.8	IXF32-7

ID Size (inch)	Ferrule Size (mm)	Hose OD (mm)		Part No.
		From:	To:	
2½	77.8	76.2	77.8	IXF40-1
2½	79.4	77.8	79.4	IXF40-2
2½	81.0	79.4	81.0	IXF40-3
2½	84.1	82.6	84.1	IXF40-5
2½	85.7	84.1	85.7	IXF40-6
2½	87.3	85.7	87.3	IXF40-7
2½	88.9	87.3	88.9	IXF40-8
3	90.5	88.9	90.5	IXF48-T
3	92.1	90.5	92.1	IXF48-U
3	82.3	92.1	93.7	IXF48-V
3	95.3	93.7	95.3	IXF48-W
3	96.8	95.3	96.8	IXF48-X
3	98.4	96.8	98.4	IXF48-Y
3	100.0	98.4	100.0	IXF48-Z
3	101.6	100.0	101.6	IXF48-1
3	103.2	101.6	103.2	IXF48-2
3	104.8	103.2	104.8	IXF48-3 <sup>1</sup>
3	106.4	104.8	106.4	IXF48-4 <sup>1</sup>
3	108.0	106.4	108.0	IXF48-5 <sup>1</sup>
4	117.5	115.9	117.5	IXF64-T
4	119.1	117.5	119.1	IXF64-U
4	120.7	119.1	120.7	IXF64-V
4	122.2	120.7	122.2	IXF64-W
4	123.8	122.2	123.8	IXF64-X
4	125.4	123.8	125.4	IXF64-Y
4	127.0	125.4	127.0	IXF64-Z
4	128.6	127.0	128.6	IXF64-1
4	130.2	128.6	130.2	IXF64-2 <sup>1</sup>
4	131.8	130.2	131.8	IXF64-3 <sup>1</sup>
4	133.4	131.8	133.4	IXF64-4 <sup>1</sup>
4	134.9	133.4	134.9	IXF64-5 <sup>1</sup>

<sup>1</sup> For hoses that use IXF48-3 to IXF48-5 and IXF64-2 to IXF64-5, contact Dixon™ for working pressure

## Dubl-Grip® Reattachable Couplings for Pump Hose



B

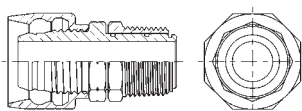

### Features:

- Two-piece construction
- Streamlined design prevents damage to hose and fits well on new pump equipment
- Wide, flat surfaces of body threads protect inside of hose from breaking
- Tapered surface of sleeve and body cradle hose prevents one-point strain from flexing
- Hose is gripped on its full circumference in two places, ensuring a rigid leakproof connection
- Reattachable: worn portion of hose can be removed and dubl-grip® can be reapplied
- Easy assembly:
  - Hose is held in position by sleeve as body is threaded home
  - Only a wrench is required to assemble the Dubl-Grip®
- UL approved

### Dubl-Grip® Reattachables - Non-Swivel

Hose ID Size (inch)	NPT Male Size (inch)	Hose OD Size (inch)	Part No.
5/8	3/4	1	850212
5/8	3/4	1-1/32	850213
5/8	3/4	1-1/16	850214
3/4	3/4	1 1/4	850451
3/4	3/4	1-13/64	850455
3/4	3/4	1 1/4	850453
1	1	1 3/4	850841 <sup>1</sup>
1	1	1-7/16	850801 <sup>1</sup>
1	1	1 1/2	850811 <sup>1</sup>

<sup>1</sup> Octagonal shape.



- Reattach static wire if required



## Maximum Recommended Working Pressures in PSI at 21°C (70°F) Ambient Temperature

Holedall™ couplings are never to be used for steam service at any pressure regardless of coupling style.

Holedall™ fittings listed below are not to be used with cable reinforced high-pressure hose, 4-or 6-braid wire hydraulic hose or any other service not listed in recommendations. Contact your local Dixon™ representative for recommendations on usage.

For Holedall™ couplings to perform satisfactorily they must be assembled properly in accordance with Dixon™'s assembly procedures, using the correct die and ferrule for that particular hose end OD. Dixon™'s Die and Ferrule Recommendation Guide is to be used to select the correct dies and ferrules.



Size NB	Externally Swaged Couplings					Internally Expanded Couplings	
	Standard Fittings <sup>1</sup>	Long Style Fittings <sup>1</sup>	Light Duty Fittings		Cam & Groove <sup>1</sup>	Internally Expanded <sup>1</sup>	Flow Chief Fittings <sup>1</sup>
			TO Ferrules, Notched Fittings <sup>1</sup>	Notched Short Fittings <sup>1</sup>			
TM, TP, TG	TML, TPL, TGL	TM, TP, TG RN-NO	RST***NOS, GAS***NOS	GAS***NOS	IXM, IXV, IXH	IXSE, IXFS, IXMS	
25	-	-	-	-	250	600	-
32	600	1,000	350	-	250	600	-
40	600	1,000	350	250	250	600	250
50	600	1,000	350	250	250	600	250
65	600	1,000	250	-	150	600	250
75	600	1,000	250	250	125	600 *	250
100	500	850	250	**	100	500 *	250
125	450	750	-	-	-	-	-
150	400	700	-	-	-	500	-
200	350	600	-	-	-	-	-
250	300	550	-	-	-	-	-

<sup>1</sup> Maximum recommended working pressures, in PSI, given at 21°C (70°F) ambient temperature

Note: The assembly's (hose + coupling) maximum working pressure is the lesser of:

- 1) The hose rated working pressure, or
- 2) The coupling rated working pressure

\* For hoses which use IXF48-3 to IXF48-5 and IXF64-2 to IXF64-5, consult Dixon™ for working pressures.

See notes below for specific recommendations.

\*\* Contact Dixon™ for pressure recommendations

**Standard Fittings**

Recommended for use at most one, and two-wire braid reinforced hoses, fibre braided and helical wire reinforced hose, such as: oil suction and discharge hose, barge and dock loading and unloading hose, LP gas hose, anhydrous ammonia hose, aircraft refuelling hose, and acid chemical hose.

**Long Style Fittings**

Recommended for use on hose as listed under standard fittings where additional retention is required due to higher working pressures or end pull. Consult maximum working pressure chart or contact Dixon™.

**Holedall™ II Fittings**

Recommended for Royalflex 1193 and 1196 hose or hoses with similar construction, having helical wire for a given OD range.

**Internally Expanded Couplings**

Recommended for use in the same applications as standard fittings, except helical wire reinforced hose such as: A210 water suction and discharge, A430 petrol / oil suction and discharge hose.

**Light Duty Fittings**

Recommended for use in the same applications as standard fittings, except that the hose rated working pressure is never to exceed the maximum recommended working pressure listed in the chart above.

 NOTE: Hose service working pressure (including surges and spikes) is never to exceed the maximum recommended working pressure for the fitting (reference chart above). Safety King Cables™ are recommended for use whenever possible. Media being transported through the hose should be compatible with the stem material and ferrule material whenever possible. Consult Dixon™'s compatibility chart for material compatibility. For applications other than the ones listed please contact Dixon™.

# Clamps Index

C

Double Ear Clamps.....	137
Service Kit .....	137
Clamp Tools .....	137
Worm Gear .....	138-140
Super Clamps .....	141
K-Series .....	142
F-Series .....	142
Ultra-Lok® .....	143
Band & Buckle .....	144
Minsup™ Claw .....	145
Chain Restrainer.....	145
Boss™ .....	146-147
Air King™ .....	148
Double Bolt .....	148
Saddle Clamp.....	149
Safety Clamps BS EN.....	149
Spiral Clamps.....	150



## Double Ear Pinch-On Clamps

<b>Features:</b>		<ul style="list-style-type: none"> <li>When ordering double ear clamps, select the nominal clamp size nearest to, but always larger than, the OD of the hose to be clamped after the hose has been fitted to the end fitting.</li> </ul>	
<b>Materials:</b>		<ul style="list-style-type: none"> <li>Zinc plated steel</li> </ul>	
Nominal Size (inch)	Size Range (mm)		Part No.
3/16	3.4	5.0	0305
1/4	5.0	7.0	0507
5/16	7.0	9.0	0709
3/8	8.1	11.0	0811
1/2	10.8	13.0	1113
9/16	12.5	15.0	1315
19/32	14.0	17.0	1517
5/8	16.0	19.0	1518
3/4	16.2	20.0	1720
13/16	18.0	22.0	1922
7/8	19.0	23.0	2023
15/16	21.0	25.0	2225
1	22.5	27.0	2327
1-1/8	26.3	31.0	2731
1-7/16	32	37.0	3437
1-1/2	35	40.0	3740

\* Sold in boxes of 100 only

## Pinch-On Clamp Service Kits

Product Information	
<ul style="list-style-type: none"> <li>15 of Part No. 0709</li> <li>15 of Part No. 0911</li> <li>15 of Part No. 1113</li> <li>15 of Part No. 1315</li> <li>15 of Part No. 1518</li> </ul>	<ul style="list-style-type: none"> <li>12 of Part No. 1720</li> <li>12 of Part No. 2023</li> <li>12 of Part No. 2225</li> <li>12 of Part No. 2327</li> <li>1 pair of standard jaw pincers Part No. 1098</li> </ul>
<b>Part No.</b>	
SK1098	

Plastic kit box contains all zinc plated 2-ear clamps.



## Clamp Tools for Pinch-On Clamps

Standard Jaw	
<b>Part No.</b>	
1098	
Side Jaw	
<b>Part No.</b>	
1099	



**Dixon™ Worm Gear Clamps**

<b>Features:</b>	<ul style="list-style-type: none"> <li>• Clamp meets SAEJ1508, which supercedes Mil Spec WW-C-440B</li> <li>• Four-piece construction</li> <li>• Screw design: 8mm slotted hex head</li> <li>• Maximum recommended torque: 30 in./lbs.</li> <li>• <b>All clamps sold 10 per box</b></li> </ul>
<b>Materials:</b>	<p>Style HS material:</p> <ul style="list-style-type: none"> <li>• Band and housing: SAE 300 series stainless</li> <li>• Screw: SAE 1018 case-hardened, hex-free chrome zinc-plated steel</li> </ul> <p>Style HSS material:</p> <ul style="list-style-type: none"> <li>• Band and housing: SAE 300 series stainless</li> <li>• Screw: SAE 300 series stainless</li> </ul>

C



Hose OD Range (mm)		Box Qty	Style HS Clamps	Style HSS Clamps
From:	To:		Part No.	Part No.
<b>12.7mm (1/2") Band Width</b>				
11	20	10	HS6	HSS6
12	23	10	HS8	HSS8
14	27	10	HS10	HSS10
17	32	10	HS12	HSS12
21	38	10	HS16	HSS16
21	45	10	HS20	HSS20
27	51	10	HS24	HSS24
33	57	10	HS28	HSS28
40	64	10	HS32	HSS32
46	70	10	HS36	HSS36
52	76	10	HS40	HSS40
59	83	10	HS44	HSS44
65	90	10	HS48	HSS48
71	95	10	HS52	HSS52
78	102	10	HS56	HSS56
84	108	10	HS60	HSS60
<b>14.3mm (9/16") Band Width</b>				
91	114	10	HS64	HSS64
48	127	10	HS72	HSS72
64	140	10	HS80	HSS80
79	152	10	HS88	HSS88
92	165	10	HS96	HSS96
105	178	10	HS104	HSS104
143	216	10	HS128	HSS128
181	254	10	HS152	HSS152
238	311	10	HS188	HSS188
257	330	10	HS200	HSS200
276	350	10	HS212	HSS212
295	368	10	HS224	HSS224
315	387	10	HS236	HSS236
334	406	10	HS248	HSS248
435	508	10	HS312	HSS312



Maximum recommended torque: 30 in./lbs.  
Torque ratings given on this page correspond to the torque rating of the screw of the clamp and are not an indication of the working pressure of any hose assembly installed with this clamp.

## Dixon™ Miniature Worm Gear Clamps

<b>Features:</b>	<ul style="list-style-type: none"> <li>• Meets SAE J1508</li> <li>• Screw design: 1/4" slotted hex head</li> <li>• Maximum recommended torque: 15 in./lbs.</li> <li>• All clamps sold 10 per box</li> </ul>
<b>Materials:</b>	<p>Style MH material:</p> <ul style="list-style-type: none"> <li>• Band and housing: SAE 300 series stainless</li> <li>• Screw: SAE 1018 case-hardened, hex-free chrome zinc-plated steel</li> </ul> <p>Style MAH material:</p> <ul style="list-style-type: none"> <li>• Band and housing: SAE 300 series stainless</li> <li>• Screw: SAE 300 series stainless</li> </ul>

Hose OD Range (mm)		Style MH Part No.	Style MAH Part No.	Pkg Qty
From:	To:			
5.6	16	MH4	MAH4	10
11	20	MH6	MAH6	10
13	23	MH8	MAH8	10
14.3	27	MH10	MAH10	10
17	27	MH12	MAH12	10
24	38	MH16	MAH16	10
30	45	MH20	MAH20	10



## Dixon™ HTML Hi Torque Worm Gear Clamps

<b>Features:</b>	<ul style="list-style-type: none"> <li>• Withstands more than three times the SAE torque requirements for worm-driven clamps</li> <li>• Eight screw threads are engaged in the band simultaneously for incredible torquing drive (over 90 in./lbs.), sealing pressure and vibration resistance</li> <li>• Slotted hex head screw design</li> </ul>
<b>Materials:</b>	<ul style="list-style-type: none"> <li>• Band and housing: 300 series half hard stainless</li> <li>• Screw: 410 stainless steel screw</li> </ul>

Diameter (mm)		Part No.	Pkg Qty
From:	To:		
31	54	HTM200L	10
44	68	HTM250L	10
57	79	HTM300L	10
69	92	HTM350L	10
82	104	HTM400L	10
95	117	HTM450L	10
107	130	HTM500	10
120	142	HTM550	10
133	155	HTM600	10
146	168	HTM650	10
158	181	HTM700	10
171	193	HTM750	10
184	206	HTM800	10
196	219	HTM850	10
209	231	HTM900	10



 Torque ratings given on this page correspond to the torque rating of the screw of the clamp and are not an indication of the working pressure of any hose assembly installed with this clamp.

## Quick Release Worm Gear Clamps

**Features:**

- Suggested installation torque 25-35 in./lbs.; maximum recommended torque 50 in./lbs.
- Band and housing: 201 series stainless
- Screw design: 5/16" slotted hex head
- **Parts showing package quantities are sold in package quantities only**

**Materials:**

- Style LS:
- Screw: plated hardened carbon steel
- Style LSS:
- Screw: SAE 410 series stainless

Diameter Range (mm)		Style LS Part No.	Pkg Qty	Style LSS Part No.	Pkg Qty
From:	To:				
40	90	LS48	10	LSS48	10
25	100	LS56	10	---	---
50	125	LS72	10	LSS72	10
52	150	LS88	10	LSS88	10
90	166	LS96	---	---	---
73	177	LS104	10	LSS104	10
45	217	LS128	---	LSS128	---
50	254	LS152	---	---	---
52	312	LS188	---	LSS188	---
256	355	---	---	LSS216	---
45	406	---	---	LSS248	---
48	508	---	---	LSS312	---

## Worm Gear Make-A-Clamp Kits

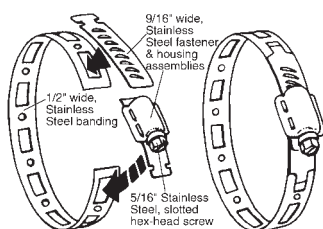
**Features:**

- A reusable maintenance clamp system in a box. By cutting off a piece of banding from a continuous roll, you can make any size stainless steel worm-driven clamp from 2" diameter and up. Perfect for applications varying sized large clamps.

**Materials:**

- Band and housing: 300 stainless<sup>1</sup>
- Screw: 410 stainless

**Design:**

- Band width: 1/2"
- Band thickness: .023"
- 5/16" slotted hex head

Contents	Stainless Steel
	Part #
Mini kit: 8 1/2' band, 3 adjustable fasteners, 1 band splice	4000
Kit with 100' band, 25 adjustable fasteners, 10 band splices	4001
Kit with 50' band, 10 adjustable fasteners, 5 band splices	4002
Box with 10 adjustable fasteners: priced per box	4004
Box with 100' band, 10 band splices	4005
Box with 50' band, 5 band splices	4006
6" Demonstrator kit with clamps	4007
Box with 10 band splices: priced per box	4008



Torque ratings given on this page correspond to the torque rating of the screw of the clamp and are not an indication of the working pressure of any hose assembly installed with this clamp.

## Single Bolt Super Clamp

**Materials:**

- Band and bridge: carbon steel
- Screw: 8.8 grade steel
- Zinc plate
- Also available in stainless steel on request

Hose OD Range (mm)		Part No.	Torque (In/lbs)
From:	To:		
17	19	SC019	31
20	22	SC022	31
23	25	SC025	31
26	28	SC028	31
29	31	SC031	53
32	35	SC035	53
36	39	SC039	53
40	43	SC043	53
44	47	SC047	106
48	51	SC051	106
52	55	SC055	106
56	59	SC059	106
60	63	SC063	106
64	67	SC067	106
68	73	SC073	168
74	79	SC079	168
80	85	SC085	168
86	91	SC091	168
92	97	SC097	168
98	103	SC103	168
104	112	SC112	168
113	121	SC121	168
122	130	SC130	168
131	139	SC139	332
140	148	SC148	332
149	161	SC161	332
162	174	SC174	332
174	187	SC187	332
188	200	SC200	332
201	213	SC213	332
214	226	SC226	332
227	239	SC239	332
240	252	SC252	332



C

## K Series Band Style Clamps

<b>Features:</b>	<ul style="list-style-type: none"> <li>• Can be center punched or rolled over; install with the center punch or roll over tools</li> <li>• Fast-Lok™ tools: F1, F40, F100</li> <li>• Super Strap Tools: 51960 screw action with 51970 adaptor page 144</li> <li>• Bandit®: S100 air tool with S180 Jr. head, C-001 hand tool with J001 Jr. adaptor, S350 air tool with S260 Jr. head, T-240 for 3/8" only or T-250 for 3/8" and 5/8", S-38 for 3/8" and 5/8", J-102 Pok-It™ for 3/8" only</li> <li>• Punch-Lok® tools: P-1000 for 3/8" and 5/8", P-3000 for 3/8" only, P-38 for 3/8" and 5/8"</li> <li>• <b>Sold in package quantities only</b></li> </ul>
<b>Materials:</b>	<ul style="list-style-type: none"> <li>• On stainless clamps, bands are 300 series stainless steel, buckles are 302 series stainless steel</li> </ul>



Clamp ID (inch)	Stainless Steel Part No.	Box Qty
<b>3/8" Wide - 0.64mm Thick</b>		
1 3/16	KS3	100
1 3/8	KS311	100
<b>5/8" Wide - 0.76mm Thick</b>		
1	KS4	100
1 1/4	KS5	100
1 1/2	KS6	100
1 3/4	KS7	100
2	KS8	100
2 1/4	KS9	100
2 1/2	KS10	50
2 3/4	KS11	50
3	KS12	50
3 1/2	KS14	50
4	KS16	25
4 1/2	KS18	25
5	KS20	25
6	KS24	25
7	KS28	25
8	KS32	25

## F Series Centre Punch Band Style Clamps

<b>Features:</b>	<ul style="list-style-type: none"> <li>• Install with center punch tools F1, F38, F40 and F100. Other manufacturers' punch style tools may also be used</li> <li>• <b>Sold in package quantities only</b></li> </ul>
<b>Materials:</b>	<ul style="list-style-type: none"> <li>• On stainless clamps, bands are 300 series stainless steel, buckles are 302 series stainless steel</li> </ul>



Style F  
(Pre-formed)

Clamp ID (inch)	Stainless Steel Part No.	Box Qty
<b>3/8" Wide - 0.51mm Thick</b>		
1 3/16	FS3	100
1 3/8	FS311	100
<b>5/8" Wide - 0.56mm Thick</b>		
1	FS4	100
1 1/4	FS5	100
1 1/2	FS6	100
1 3/4	FS7	100
2	FS8	100
2 1/4	FS9	100
2 1/2	FS10	50
2 3/4	FS11	50
3	FS12	50
3 1/2	FS14	50
4	FS16	25
4 1/2	FS18	25
5	FS20	25
6	FS24	25
7	FS28	25
8	FS32	25



## Ultra-Lok® Band Style Clamping Systems

<b>Features:</b>	<ul style="list-style-type: none"> <li>Ultra-Lok® provides a fast, reliable, consistent clamp made from high tensile 201 stainless steel ¼ hard for unequalled strength and reliability. The powerful, portable UL9000 tool lets you apply clamps anywhere there is an AC outlet. Ultra-Lok®'s smooth ID seals tight with a gap-free, 360° seal, and since the design allows locking under full tension, clamps resist rotation on pole applications.</li> <li>Speed/torque setting on tool for consistent repeatable tensioning</li> </ul>
<b>Materials:</b>	<ul style="list-style-type: none"> <li>201 stainless steel</li> </ul>
<b>Size:</b>	<ul style="list-style-type: none"> <li>Preformed ¾" width clamps available in sizes from 2" to 9" diameter</li> </ul>

Ultra-Lok® Smooth ID Clamps		
Clamp ID (inch)	Part No.	Box Qty
2	UL227	100
2¾	UL210	50
3	UL211	50
3½	UL212	50
4	UL213	25
4½	UL214	25
5	UL215	25
6½	UL217	25
7	UL218	25
8	UL219	25
9	UL228	10

Ultra-Lok® Electric Installation Tool	
Description	Part No.
Ultra-Lok® tool (excludes drill)	UL0015
Ultra-Lok® drill (excludes tool) (AC power unit)	ULM067

Note: Both drill and attachment sold separately.

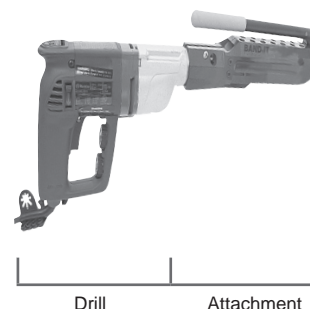

Drill Attachment

## Band Clamp Hand Tools

Hand-Held Tool	
Description	Part No.
hand-held tool for application of ¾" and 5/8" band clamps	F100



## Clamp-it Band & Buckles



Strapping - 100 ft Per Box (30.4 Mtrs)			
Width (inch)	Thickness (mm)	Galvanised Part No.	201 Stainless Part No.
3/8	0.64	SG375	SS375
1/2	0.76	SG500	SS500
5/8	0.76	SG625	SS625
3/4	0.76	SG750	SS750



Buckles			
Width (inch)	Galvanised Part No.	201 Stainless Part No.	Box Qty
3/8	CG375	CS375	100
1/2	CG500	CS500	100
5/8	CG625	CS625	100
3/4	CG750	CS750	50

To be used with C2 or 51960 band clamp tools as shown below

## Band Clamp Hand Tools

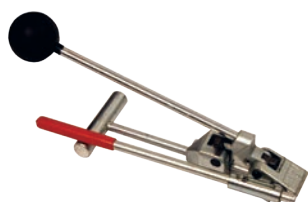

Jack Type	
Description	Part No.
clamping tool for band and buckles, lightweight, side-entry	C2



Jack Type	
Description	Part No.
Hand tool for application of 5/8" band clamps	F1



Screw Action Type	
Description	Part No.
Clamping Tool for band and buckles; for vice applications only	51960



Adaptor	
Description	Part No.
Adaptor for installing preformed clamps; For p/n 51960	51970

## Minsup™ Safety Claw Clamps



<b>Material:</b>	SG Iron ISO 1083
<b>Protection:</b>	Zinc plated
<b>Inserts:</b>	Inserts in ½", ¾" and 1" clamps are made from nylon

Nom. ID (inch)	Hose OD (mm)		Bolt Torque		Part No.	Pkg Qty
	From:	To:	ft./lbs.	Nm		
½	22	28	18.4	25	08/023/42/000	100
¾	29	34	18.4	25	08/023/43/000	50
1	35	40	25.8	35	08/023/46/000	50



 Selecting the correct clamping device is critical to the performance and safety of any hose assembly. The clamp provides a combination of friction and lock in retaining the coupling to the hose.

If you are unsure of the correct clamp for the application, coupling, or hose type, contact Dixon™ on +44 (0)1772 323529.

Without Chain						
Nom. ID (inch)	Hose OD (mm)		Bolt Torque		Part No.	Pkg Qty
	From:	To:	ft./lbs.	Nm		
1½	51	58	50	67.8	08/023/05/000	20
2	65.5	71	60	81.3	08/023/03/000	15



With Chain						
Nom. ID (inch)	Hose OD (mm)		Bolt Torque		Part No.	Pkg Qty
	From:	To:	ft./lbs.	Nm		
1½	51	58	50	67.8	08/023/06/000	20
2	65.5	71	60	81.3	08/023/04/000	15



 **WARNING:** Worn-out hose fittings should be replaced. Loose clamps on hose can be dangerous. Bolt type clamps should be retensioned regularly. For extra safety, retaining devices such as clips, chains, or cables must be used. Dixon™ strongly recommends the use of a safety tag or warning label on all hose assemblies. Refer to technical section for more information.

## Chain Restrainers

Suits Clamp Size (inch)	Chain Size (inch)	Part No.
1½ and 2	½	08/023/01/047A

For use with Minsup™ double bolt claw clamp.  
 Replacement chain to suit 1½" & 2" clamp size



 Not recommended as a replacement for a whipcheck. Refer to page 54 for additional information. Please contact Dixon™ for further information.

## Minsup™ Double Bolt Clamps

Nom. ID (inch)	Hose OD (mm)		Torque		Part No.	Pkg Qty
	From:	To:	ft./lbs.	Nm		
½	24	27	18.4	25	08/023/14/000	100
¾	31	33	18.4	25	08/023/15/000	50
1	37	39	25.8	35	08/023/13/000	50



**Boss™ Clamps**

The bolts used in the Boss™ interlocking clamps are not standard bolts. They vary from standard bolts in their length, diameter, overall thread length and material hardness. These bolts can be re-torqued, but it is **not** recommended that the bolts or clamps be reused, as they are designed for a single bend only. Dixon™ recommends using only factory-supplied replacement bolts. Torque values for clamps are based on dry bolts. The use of lubricant on bolts will adversely effect clamp performance. *Do not lubricate nuts and bolts.* For all bolt tightening sequences, please visit [europe.dixonvalve.com](http://europe.dixonvalve.com)

**2 Bolt Type Clamps**

C



2 Bolt Type, 2 Gripping Fingers

**Features:**

- Recommended for steam service up to **232°C (450°F)**
- Recommended torque rating in ft./lbs.
- Replacement nuts and bolts are available; contact Dixon™ for more information

**2 Bolt Type, 2 Gripping Fingers**

Hose ID (inch)	Hose OD (inch)		Zinc Plated Iron Part #	Pkg Qty	Stainless Steel Part #	Torque ft./lbs. <sup>1</sup>	Brass Part #	Pkg Qty
	from	to						
¼	36/64	42/64	BD <sup>1</sup>	100	---	6	---	---
¾	44/64	56/64	CD <sup>1</sup>	100	---	6	---	---
½	52/64	60/64	DD <sup>1</sup>	100	---	6	---	---
½	60/64	1-4/64	B4 <sup>1</sup>	25	RB4	12	BB4	10
½	1-4/64	1-12/64	B5	25	---	12	---	---
¾	1-10/64	1-20/64	BU9 <sup>1</sup>	50	RBU9	21	BBU9	18
¾	1-20/64	1-32/64	B9	25	RB9	21	---	---
¾	1-32/64	1-44/64	B10 <sup>1</sup>	25	---	21	---	---

**4 Bolt Type Clamps**

4 Bolt Type, 2 Gripping Fingers

**4 Bolt Type, 2 Gripping Fingers**

Hose ID Size (inch)	Hose ID Size (mm)	Hose OD (mm)		Torque <sup>1</sup> ft./lbs.	Zinc Plated Iron Part No.	Stainless Steel Part No.	Brass Part No.	Pkg Qty
		To:	From:					
1	25	38.9	43.7	21	BU14	RBU14	BBU14	25
1	25	42.9	49.2	21	B14	RB14	---	25
1	25	49.2	54.0	21	B15	---	---	20
1¼	32	38.1	45.2	40	BU18	---	---	10
1¼	32	45.2	53.2	40	BU19	---	---	10
1¼	32	54.0	60.3	40	B19	RB19	---	10
1½	40	46.0	50.8	40	BU22	---	---	10
1½	40	50.8	56.4	40	B22	---	---	10
1½	40	55.6	60.3	40	BU24	RBU24	---	10
1½	40	60.3	65.1	40	B24	RB24	---	10
1½	40	65.1	69.9	40	B25	---	---	10
2	50	59.5	64.3	60	BU28	---	---	10
2	50	63.5	70.6	60	BU29	RBU29	BBU29	10
2	50	69.9	77.8	60	B29	RB29	---	10
2	50	78.6	87.3	60	B30	---	---	5
2½	65	78.6	87.3	60	BU34	---	---	5
2½	65	88.9	100.0	150	B34	---	---	5
3	75	88.9	100.0	150	BU35	RBU35	---	5
3	75	96.8	103.2	150	B35	---	---	5
3	75	103.2	112.7	200	B39	---	---	5

<sup>1</sup> Torque applies to plated iron and stainless steel clamps

## 4 Bolt Type Clamps

4 Bolt Type, 4 Gripping Fingers						
Hose ID Size (inch)	Hose ID Size (mm)	Hose OD (mm)		Torque <sup>1</sup> ft./lbs.	Zinc Plated Iron Part No.	Pkg Qty
		To:	From:			
½	15	23.0	26.2	6	968	50
1	25	35.7	39.7	21	156 <sup>2</sup>	20
1¼	32	42.9	47.6	21	187 <sup>2</sup>	10
1¼	32	47.6	52.4	21	206 <sup>2</sup>	20
1½	40	50.8	54.0	21	212 <sup>2</sup>	10
1½	40	52.4	57.2	40	225 <sup>2</sup>	10
2	50	57.2	63.5	40	250 <sup>2,3</sup>	10
2	50	63.5	69.9	40	275 <sup>2,3</sup>	10
2	50	69.9	77.8	60	306 <sup>2,3</sup>	10
2½	65	77.8	88.9	60	350 <sup>2</sup>	5
3	75	88.9	95.3	60	375 <sup>2</sup>	5
3	75	95.3	101.6	150	401 <sup>2</sup>	5
3	75	101.6	106.4	200	418 <sup>2</sup>	4
3	75	106.4	114.3	200	450 <sup>2</sup>	2



4 Bolt Type, 4 Gripping Fingers

## 6 Bolt Type Clamps

6 Bolt Type, 3 Gripping Fingers						
Hose ID Size (inch)	Hose ID Size (mm)	Hose OD (mm)		Torque <sup>1</sup> ft./lbs.	Part No.	Pkg Qty
		To:	From:			
3	76	107.9	122.2	150	BS39	2
4	101	117.4	127.0	150	B45	3
4	101	123.8	133.3	200	BS49	2
4	101	133.3	142.0	200	BU49	2
4	101	140.4	150.8	200	B49	2



6 Bolt Type, 3 Gripping Fingers

6 Bolt Type, 6 Gripping Fingers						
Hose ID Size (inch)	Hose ID Size (mm)	Hose OD (mm)		Torque <sup>1</sup> ft./lbs.	Part No.	Pkg Qty
		To:	From:			
6	150	174	187	200	750	1
6	150	190	203	200	850	1



6 Bolt Type, 6 Gripping Fingers

<sup>1</sup> Torque applies to plated iron and stainless steel clamps

<sup>2</sup> 4 gripping fingers

<sup>3</sup> Not to be used with GF81, GB26, WF81, B26, RGF81, RGB26, BGF81, BGB26, RWF81, RB26

**Air King™ Double Bolt Clamps****Features:**

- Torque values for clamps are based on dry bolts. The use of lubricant on bolts will adversely effect clamp performance
- For use with Air King™ ends

**Plated Iron**

Hose ID Size (inch)	Hose OD Range (mm)		Torque ft./lbs.	Part No.
	From:	To:		
½	25.4	30.2	6	A4
¾	28.6	33.3	12	A9
1	33.3	38.1	12	A10 <sup>1,2</sup>
1	38.1	46.0	21	A14

<sup>1</sup> Can be used with **AM6** and **AM11**

<sup>2</sup> Global investment cast carbon steel

**Dixon™ Double Bolt Clamps****Features:**

- Inner surface has dual gripping ridges
- Bolt lugs are reinforced to prevent bending out of alignment
- Torque values for clamps are based on dry bolts
- The use of lubricant on bolts will adversely affect clamp performance
- Measure hose OD accurately before ordering clamps
- Consult Dixon™ when using double bolt clamps on helical wire hose

Hose OD (mm)		Torque ft./lbs.	Part No.
From:	To:		
<b>Double Bolt Clamp Without Saddles</b>			
28.6	30.2	15	J48
30.2	34.9	21	J49
36.5	38.9	21	JX49
41.3	46.0	40	DL14
44.5	52.0	27	DL20
53.6	58.3	27	DL24 <sup>1</sup>
58.7	66.7	40	DL32 <sup>1</sup>
63.5	69.9	40	DL275
69.9	77.8	60	DL306
77.8	85.7	60	DL328
82.6	88.9	60	DL350
<b>Double Bolt Clamp With 2 Saddles</b>			
88.9	96.8	40	400
96.0	103.2	40	431
102.4	108.7	40	463
108.0	125.4	60	525
114.3	133.4	60	550
130.2	144.5	60	600
144.5	150.8	60	639
150.8	165.1	60	675
165.1	192.1	60	769
195.3	208.0	125	818
209.6	225.4	125	875
227.0	250.8	125	988
252.4	288.9	125	1125
284.2	330.2	125	1275
309.6	355.6	200	1360
335.0	381.0	200	1450
382.6	444.5	260	1700

<sup>1</sup> Investment carbon steel



- Consult Dixon™ when using double bolt clamps on helical wire hose.
- NOTE: Measure hose OD accurately before ordering clamps

## Series TSC - Two Bolt Saddle Clamps

- Features:**
- More than one clamp may be needed per size. Contact the hose manufacturer for more information
  - For use on convoluted cover hose
  - To determine which style clamp is needed for your hose, look at the end of the hose; if the helix spirals in a clockwise direction away from you (along the hose), a clockwise clamp is needed. If the helix spirals in a counterclockwise direction away from you, a counterclockwise clamp is needed. Examples include, but are not limited to: Kuriyama convoluted hose uses counterclockwise clamps; Pacific Echo and Kana Flex use clockwise clamps; Goodyear uses both counterclockwise and clockwise.

Hose ID				Material	Part No.
inch		mm			
From:	To:	From:	To:		
5/8	15/16	17	22	Malleable Iron	TSC 25
15/16	1 1/8	22	29	Malleable Iron	TSC 31
1 1/16	1 1/4	27	32	Malleable Iron	TSC 34
1 1/4	1 7/16	32	37	Malleable Iron	TSC 37
1 1/2	1 15/16	39	49	Malleable Iron	TSC 1305
1 29/32	2 3/8	48	60	Malleable Iron	TSC 1306
2 3/8	3 1/64	60	76	Malleable Iron	TSC 1307
3 1/32	3 11/16	77	94	Malleable Iron	TSC 1308
3 11/16	4 1/2	94	115	Malleable Iron	TSC 1309
1 1/8	1 1/4	28	32	Investment Cast Steel <sup>1</sup>	TSK34

<sup>1</sup> With safety claws



TSC Series



TSK Series



## Safety Clamps BS EN 14420-3:2004

Hose ID (mm)	Wall Thickness (mm)	Aluminium Part No.	Stainless Steel Part No.
13	6	SC13X6AL	---
19	6	SC19X6AL	SC19X6SS
25	6	SC25X6AL	SC25X6SS
32	6	SC32X6AL	---
38	6.5	SC38X6.5AL	SC38X6.5SS
38	8	SC38X8AL	SC38X8SS
38	10	SC38X10AL	---
50	6	---	SC50X6SS
50	8	SC50X8AL	SC50X8SS
50	10	SC50X10AL	SC50X10SS
63	8	SC63X8AL	SC63X8SS
65	7	---	SC65X7SS
65	10	SC65X10AL	---
75	7.5	SC75X7.5AL	SC75X7.5SS
75	10	SC75X10AL	---
100	8	SC100X8AL	---
100	10	SC100X10AL	---
100	12	SC100X12AL	---
150	10	SC150X10AL	---



## Clockwise Wound (Right Hand) Spiral Clamps

**Features:**

- More than one clamp may be needed per size. Contact the hose manufacturer for more information
- For use on convoluted cover hose
- To determine which style clamp is needed for your hose look at the end of the hose; if the helix spirals in a clockwise direction away from you (along the hose), a clockwise clamp is needed. If the helix spirals in a counterclockwise direction away from you, a counterclockwise clamp is needed. Examples include, but are not limited to: Kuriyama convoluted hose uses counterclockwise clamps; Pacific Echo and Kana Flex use clockwise clamps; Goodyear uses both counterclockwise and clockwise.

Hose ID Size (inch)	Part No.
1½	SC150
2	SC200
2½	SC250
3	SC300
4	SC400
5	SC500
6	SC600
8	SC800
10	SC1000
12	SC1200



Due to fluctuations in the OD of hose each individual installation should be checked

## Anti-Clockwise Wound (Left Hand) Spiral Clamps



Hose ID Size (inch)	Part No.
1½	SCCW150
2	SCCW200
2½	SCCW250
3	SCCW300
4	SCCW400
5	SCCW500
6	SCCW600
8	SCCW800
10	SCCW1000
12	SCCW1200



D



Safety Break-Away Couplings.....	152-156
Dry Quick Disconnect .....	157-159
Dry Aviation.....	160-161
Dry Gas .....	162
Dry Break Cam & Groove.....	163-164
Bayonet Style.....	165



# Dry Disconnect Fittings

## Safety Break-Away Couplings - Breaking Bolt Series Industrial Version



<b>Application:</b>	The breaking bolt industrial breakaway coupling is designed to minimise spillage and damage associated with drive away and pull away incidents.
<b>Design:</b>	Coupling automatically senses an excessive load, closes the valves and disconnects. Simple mechanism, no loose components lost after release. High flow rate / low pressure drop. Female NPT & BSP is standard, optional ANSI / DIN flanges are available. 10" and 12" sizes also available; consult Dixon™ for more information.
<b>Material:</b>	<ul style="list-style-type: none"> <li>Stainless steel or aluminium; others on request</li> </ul>
<b>Working Pressure:</b>	<ul style="list-style-type: none"> <li>SS - 360 PSI @ 21°C (70°F)</li> <li>AL - 230 PSI @ 21°C (70°F)</li> </ul>
<b>Seal:</b>	<ul style="list-style-type: none"> <li>FKM is standard seal</li> </ul>

Size (inch)	Width (mm)	Length (mm)	Weight (kg)		Flow Rate / LPM
			SS	AL	
2	114	178	2.3	1.4	757
3	173	279	8.2	3.6	2460
4	210	305	15.4	6.4	3028
5	269	356	32.3	12.3	4164
6	305	406	45.9	15.9	5678
8	343	450	71.4	30	14000

D

### Industrial Version - Female x Female



Size (inch)	DN	Stainless Steel	Aluminium
		Part No.	Part No.
<b>NPT</b>			
2	50	SBC200SS-DE	SBC200AL-DE
3	80	SBC300SS-DE	SBC300AL-DE
4	100	SBC400SS-DE	SBC400AL-DE
5	125	SBC500SS-DE	SBC500AL-DE
6	150	SBC600SS-DE	SBC600AL-DE
<b>BSP</b>			
2	50	SBC200SSA-DE	SBC200ALA-DE
3	80	SBC300SSA-DE	SBC300ALA-DE
4	100	SBC400SSA-DE	SBC400ALA-DE
5	125	SBC500SSA-DE	SBC500ALA-DE
6	150	SBC600SSA-DE	SBC600ALA-DE

### Industrial Version - Male x Male



Size (inch)	DN	Stainless Steel	Aluminium
		Part No.	Part No.
<b>NPT</b>			
2	50	SBC200SSMNPT-DE	SBC200ALMNPT-DE
3	80	SBC300SSMNPT-DE	SBC300ALMNPT-DE
4	100	SBC400SSMNPT-DE	SBC400ALMNPT-DE
5	125	SBC500SSMNPT-DE	SBC500ALMNPT-DE
6	150	SBC600SSMNPT-DE	SBC600ALMNPT-DE
<b>BSP</b>			
2	50	SBC200SSMBSP-DE	SBC200ALMBSP-DE
3	80	SBC300SSMBSP-DE	SBC300ALMBSP-DE
4	100	SBC400SSMBSP-DE	SBC400ALMBSP-DE
5	125	SBC500SSMBSP-DE	SBC500ALMBSP-DE
6	150	SBC600SSMBSP-DE	SBC600ALMBSP-DE

## Industrial Version - ANSI150 Flange x ANSI150 Flange

Size (inch)	DN	Stainless Steel	Aluminium
		Part No.	Part No.
2	50	SBC200SSFL-DE	SBC200ALFL-DE
3	80	SBC300SSFL-DE	SBC300ALFL-DE
4	100	SBC400SSFL-DE	SBC400ALFL-DE
5	125	SBC500SSFL-DE	SBC500ALFL-DE
6	150	SBC600SSFL-DE	SBC600ALFL-DE
8	200	SBC800SSFL-DE	---



### How it Works

Safety break-away couplings have three external break bolts. In the case of axial tension all the bolts take up the force corresponding to the break force on the hose with a safety margin. Non-axial forces concentrate the tension forces more strongly on one bolt, so that the safety break-away coupling reacts in a natural way to the reduction of the hose break forces.

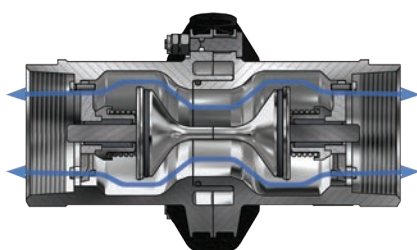

**BEFORE Emergency Disconnect**

The safety break-away valve consists of two halves, each with a valve that has an O-ring seal.

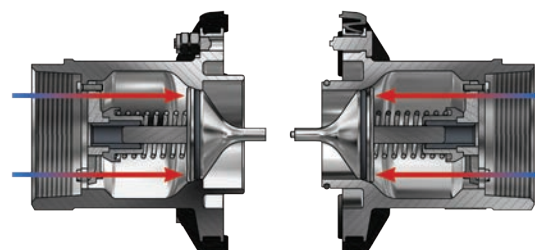

**AFTER Emergency Disconnect**

When the safety break-away couplings separate, the valves are able to close. The two valves close rapidly, minimising exposure to personnel and the environment.

### Optional Non-Closure Design

The non-closure design is an economical alternative, which allows the coupling to break away due to pull-away/drive-away incidents, thus protecting piping systems and equipment. This design allows spillage of product in these instances due to the lack of valving in the coupling. Useful in applications where non-hazardous product is being conveyed and where there are no environmental concerns. Available in both industrial and marine versions. Consult Dixon™ for more information.

# Dry Disconnect Fittings

## Safety Break-Away Couplings - Breaking Bolt Series Marine Version



<b>Application:</b>	The breaking bolt marine version break-away coupling is designed to minimise spillage and damage associated with pull-away incidents. Typical applications include: ship-to-offshore platform and ship-to-ship product transfer operations.
<b>Design:</b>	Designed to be installed within a hose string where the coupling will have a length of hose attached to both sides. Coupling automatically senses an excessive load, closes the valves and disconnects. Release is executed when force causes bolts to break. Female NPT or BSP is standard; optional ANSI / DIN flanges are available. 10" and 12" sizes also available. Consult Dixon™ for more information.
<b>Material:</b>	<ul style="list-style-type: none"> <li>• 316T1 stainless steel body with FKM O-rings</li> </ul>
<b>Working Pressure:</b>	<ul style="list-style-type: none"> <li>• 360 PSI @ 21°C (70°F)</li> </ul>

Size (inch)	Width (mm)	Length (mm)	Weight (kg)	Flow Rate / LPM
2	114	178	2.3	757
3	157	279	8.2	2460
4	210	305	15.4	3028
5	269	356	32.3	4164
6	305	406	45.8	5678
8	343	450	71.2	14000

D

### Marine Version - Female x Female



Size (inch)	DN	Stainless Steel	
		Part No.	
NPT			
2	50	MSBC200SS-DE	
3	80	MSBC300SS-DE	
4	100	MSBC400SS-DE	
5	125	MSBC500SS-DE	
6	150	MSBC600SS-DE	
BSP			
2	50	MSBC200SSA-DE	
3	80	MSBC300SSA-DE	
4	100	MSBC400SSA-DE	
5	125	MSBC500SSA-DE	
6	150	MSBC600SSA-DE	

### Marine Version - Male x Male



Size (inch)	DN	Stainless Steel	
		Part No.	
NPT			
2	50	MSBC200SSMNPT-DE	
3	80	MSBC300SSMNPT-DE	
4	100	MSBC400SSMNPT-DE	
5	125	MSBC500SSMNPT-DE	
6	150	MSBC600SSMNPT-DE	
BSP			
2	50	MSBC200SSMBSP-DE	
3	80	MSBC300SSMBSP-DE	
4	100	MSBC400SSMBSP-DE	
5	125	MSBC500SSMBSP-DE	
6	150	MSBC600SSMBSP-DE	

## Marine Version - 150# Flange x 150# Flange

Size (inch)	DN	Stainless Steel	
		Part No.	
2	50	MSBC200SSFL-DE	
3	80	MSBC300SSFL-DE	
4	100	MSBC400SSFL-DE	
5	125	MSBC500SSFL-DE	
6	150	MSBC600SSFL-DE	
8	200	MSBC800SSFL-DE	



Industrial and marine safety break-away couplings are also available in BSP thread, DN flange, 300# ASA flange, grooved ends, or any combination thereof.

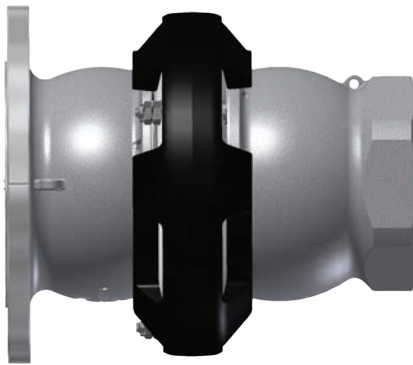

Flange / Thread  
(BSP / NPT female / male or grooved)

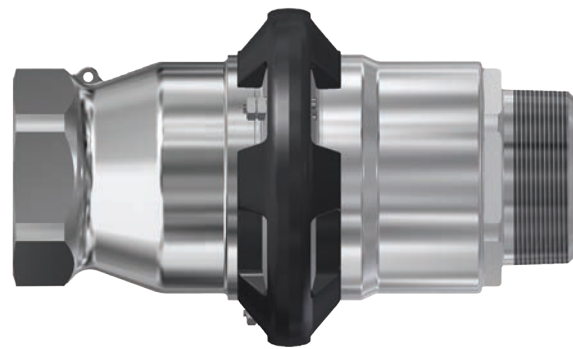

NPT Female Thread / NPT Male Thread  
(also available with BSP)

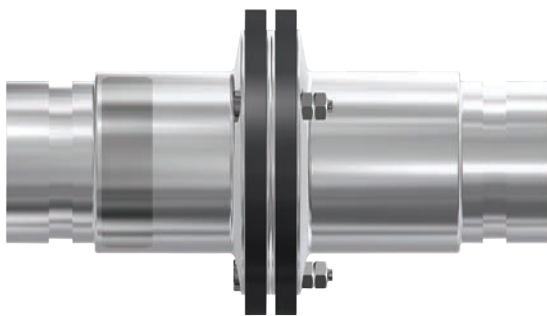

Grooved / Grooved



NPT Female Thread / Grooved

# Dry Disconnect Fittings

## Safety Break-Away Couplings - Cable Release Series



### Design:

The cable release series break-away couplings are designed to minimise spillage and damage associated with drive-away and pull-away incidents. Couplings feature a simple mechanism and no loose components to lose after release. In some applications the necessary force of the breaking bolts may be too high to prevent damage to loading arms or other pipe and equipment; under these conditions the use of cable release safety break-aways may be more suitable. Coupling automatically senses an excessive load, closes the valves and disconnects. Release is executed by pulling out the locking bolts with the help of a cable. When the coupling separates, the poppets close.

### Material:

- 316T1 stainless steel body with FKM O-rings

### Working Pressure:

- 360 PSI

### Industrial Version

Size (inch)	DN	Part No.	Width (mm)	Length (mm)	Weight (kg)	Flow Rate / LPM
1½	40	SBC150SS-CR-DE	98	142	3.1	378
2	50	SBC200SS-CR-DE	110	144	4.1	500
3	80	SBC300SS-CR-DE	145	195	8.5	1000
4	100	SBC400SS-CR-DE	185	226	16.1	1500

D

## How it Works

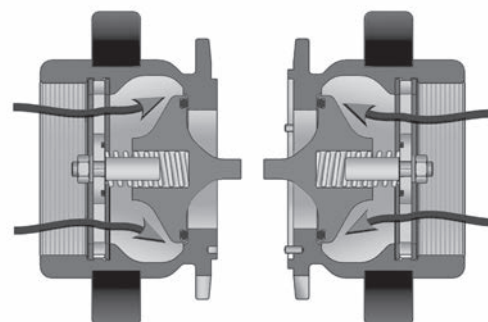
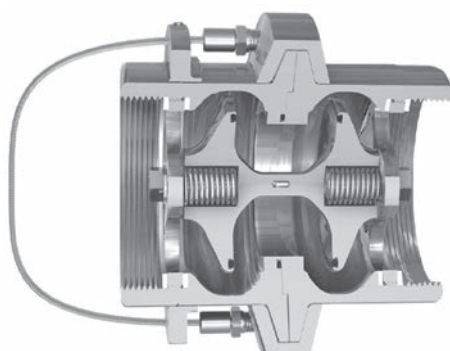

The safety break-away valve consists of two halves, each with a valve that has a flat type-sealing surface similar to a dry disconnect coupling.

When the safety break-away couplings separate, the poppets are able to close. The two poppets close rapidly, minimising exposure to personnel and the environment.

## Optional Non-Closure Design

The non-closure design is an economical alternative, which allows the coupling to break away due to pull-away / drive-away incidents, thus protecting piping systems and equipment. This design also allows spillage of product in these instances due to the lack of valving in the coupling. Useful in applications where non-hazardous product is being conveyed and where there are no environmental concerns. Available in both industrial and marine versions. Consult Dixon™ for more information.

# Dry Disconnect Fittings

## When your product is:

- Expensive
- Expensive to clean up
- Expensive to reprocess or dispose
- Hazardous to workers or the environment
- Prone to accidental spillage and product loss

Dry disconnect couplings are designed for quick and spill-free connection and disconnection of hoses and pipelines.

<b>Applications:</b>	<ul style="list-style-type: none"> <li>• Used by producers of ink, adhesives, fatty acids, pharmaceuticals, liquid soaps, petroleum, chemicals, agricultural products, and a wide variety of common caustic and specialty acids</li> <li>• Designed for the quick and spill-free connection and disconnection of hoses and pipelines</li> </ul>
<b>Features:</b>	<ul style="list-style-type: none"> <li>• Easy to handle: push and turn = free flow; turn and pull = closed</li> <li>• Time saving: no need to drain hoses or pipe systems</li> <li>• Economical: no loss or spillage of liquids at connection or disconnection</li> <li>• Safety: the valve cannot be opened until the unit is coupled</li> <li>• Environmentally friendly: accidental spillage eliminated when properly used</li> <li>• Safe and reliable: due to rugged construction</li> <li>• Product life: uncomplicated design and high-quality materials ensures long product life</li> <li>• Selectivity: To avoid product contamination, selective versions of the couplers and adaptors are available. Contact Dixon™ for further information.</li> <li>• Produced according to NATO standard STANAG 3756 and ATOFINA SGM 2049.TUY.C.</li> <li>• Working pressure at ambient temperature 21°C (70°F):               <ul style="list-style-type: none"> <li>aluminium: <b>230 PSI</b>, up to 4"</li> <li>brass/ gunmetal: <b>230 PSI</b>, up to 4"</li> <li>stainless steel: <b>360 PSI</b></li> </ul> </li> <li>• Standard seal supplied: FKM</li> <li>• Optional seals:               <ul style="list-style-type: none"> <li>EPDM</li> <li>NBR - nitrile</li> <li>Kalrez®</li> <li>Chemraz®</li> </ul> </li> <li>• Seal kits are available</li> <li>• Interchanges with Avery Hardoll and Todo-matic®</li> </ul>



D

## How it Works

The principle of operation is identical for all sizes of couplings.

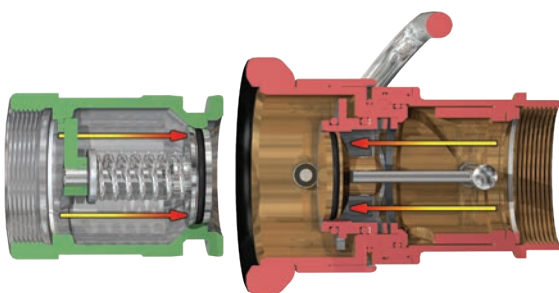

### Closed:

- Turn and pull: it's released - *no spillage*

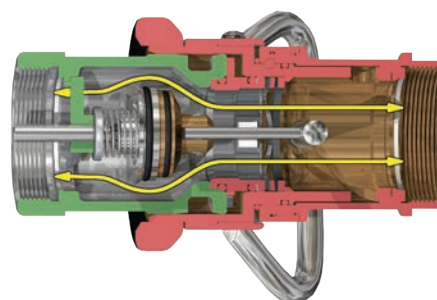

### Open:

- Push and turn: it's coupled - *full flow*

# Dry Disconnect Fittings

## Dry Quick Disconnect Coupler - Hose Unit



6" Design



3" &amp; 4" Design



1½" &amp; 2" Design



¾" &amp; 1" Design

<b>Design:</b>	<ul style="list-style-type: none"> <li>Coupler has built-in swivel and riveted piston pin to minimise the risk for failure under extreme pressure conditions.</li> </ul>
<b>Material:</b>	<ul style="list-style-type: none"> <li>Stainless steel ball bearings, shaft journal in stainless steel embedded in PTFE to eliminate seizure</li> <li>Protecting ring is weather-resistant rubber, electrically conductive</li> <li>All wetted parts are stainless steel, rollers for the stainless steel units are Hastelloy™ C276 on the stainless steel shaft</li> <li>Rollers for the aluminium and brass units are aluminium-bronze on the stainless steel shaft</li> <li>Composite plugs provide very good protection against corrosion and withstand hot and cold environments</li> </ul>

### Female NPT with FKM Seals

Female (inch)	Body Size (mm)	316 Stainless Steel	Anodised Aluminium
		Part No.	Part No.
NPT			
¾	56	DDC075SS-DE	DDC075AL-DE
1	56	DDC100SS-DE	DDC100AL-DE
1½	70	DDC150SS-DE	DDC150AL-DE
2	70	DDC200SS-DE	DDC200AL-DE
3	105	DDC300SS105-DE	DDC300AL105-DE
3	119	DDC300SS-DE	DDC300AL-DE
4	164	DDC400SS-DE	DDC400AL-DE
6	238	DDC600SS-DE	DDC600AL-DE
BSP			
¾	56	DDC075SSA-DE	DDC075ALA-DE
1	56	DDC100SSA-DE	DDC100ALA-DE
1½	70	DDC150SSA-DE	DDC150ALA-DE
2	70	DDC200SSA-DE	DDC200ALA-DE
3	105	DDC300SSA105-DE	DDC300ALA105-DE
3	119	DDC300SSA-DE	DDC300ALA-DE
4	164	DDC400SSA-DE	DDC400ALA-DE
6	238	DDC600SSA-DE	DDC600ALA-DE

### Female NPT with FKM Seals

Female (inch)	Body Size (mm)	Part No.
Brass / Gunmetal - NPT		
¾	56	DDC075BR-DE
1	56	DDC100BR-DE
1½	70	DDC150BR-DE
2	70	DDC200BR-DE
3	105	DDC300GM105-DE
3	119	DDC300GM-DE
4	164	DDC400GM-DE

## Dust Plugs for Couplers

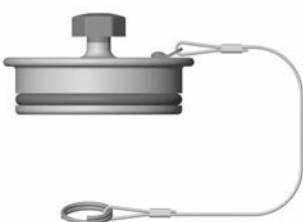

Composite		
Size (inch)	Body Size (mm)	Part No.
¾ & 1	56	DDDP075-DE
1½ & 2	70	DDDP150-DE
3	105	DDDP300105-DE
3	119	DDDP300-DE
4	164	DDDP400-DE
6	238	DDDP600-DE <sup>1</sup>

<sup>1</sup> 6" dust plug is aluminium.



## Dry Quick Disconnect Adaptor - Tank Unit

<b>Application:</b>	<ul style="list-style-type: none"> <li>The adaptor is usually typically on the tank or manifold</li> <li>Available in male and female BSP, NPT, or 150# ASA flange (ANSI)</li> </ul>
<b>Design:</b>	<ul style="list-style-type: none"> <li>Conical valve seat to eliminate the risk of "piston blow out"</li> <li>PTFE bearing between the piston shaft and the piston guide to eliminate the risk for seizure</li> </ul>
<b>Material:</b>	<ul style="list-style-type: none"> <li>Aluminium adaptor - aluminium poppet, stainless steel internal parts</li> <li>Stainless steel adaptor - stainless steel poppet, stainless steel internal parts</li> <li>Brass / gunmetal adaptor - brass poppet, brass and stainless steel internal parts</li> <li>Composite caps provide very good protection against corrosion and withstand hot and cold environments</li> </ul>

Adaptors x Female NPT with FKM Seals				
Female (inch)	Body Size (mm)	316 Stainless Steel	Brass / Gunmetal	
		Part No.	Part No.	
<b>NPT</b>				
¾	56	DDA075SS-DE	DDA075BR-DE	
1	56	DDA100SS-DE	DDA100BR-DE	
1½	70	DDA150SS-DE	DDA150BR-DE	
2	70	DDA200SS-DE	DDA200BR-DE	
3	105	DDA300SS105-DE	DDA300GM105-DE	
3	119	DDA300SS-DE	DDA300GM-DE	
4	164	DDA400SS-DE	DDA400GM-DE	
6	238	DDA600SS-DE	-	
<b>BSP</b>				
¾	56	DDA075SSA-DE	-	
1	56	DDA100SSA-DE	-	
1½	70	DDA150SSA-DE	-	
2	70	DDA200SSA-DE	-	
3	105	DDA300SSA105-DE	-	
3	119	DDA300SSA-DE	-	
4	164	DDA400SSA-DE	-	
6	238	DDA600SSA-DE	-	



Female NPT x Adaptor

Adaptors x 150# ASA (ANSI) Flange with FKM Seals				
150# Flange (inch)	Body Size (mm)	316 Stainless Steel	Anodised Aluminium	Brass / Gunmetal
		Part No.	Part No.	Part No.
¾	56	DDA075SSFL-DE	DDA075ALFL-DE	DDA075BRFL-DE
1	56	DDA100SSFL-DE	DDA100ALFL-DE	DDA100BRFL-DE
1½	70	DDA150SSFL-DE	DDA150ALFL-DE	DDA150BRFL-DE
2	70	DDA200SSFL-DE	DDA200ALFL-DE	DDA200BRFL-DE
3	105	DDA300SS105FL-DE	DDA300AL105FL-DE	DDA300GM105FL-DE
3	119	DDA300SSFL-DE	DDA300ALFL-DE	DDA300GMFL-DE
4	164	DDA400SSFL-DE	DDA400ALFL-DE	DDA400GMFL-DE
6	238	DDA600SSFL-DE	DDA600ALFL-DE	-



150# Flange x Adaptor

Adaptors x TTMA Flange with FKM Seals			
TTMA Flange (inch)	Body Size (mm)	Anodised Aluminium	
		Part No.	
3	105	DDA300AL105TTMA-DE	
3	119	DDA300AL119TTMA-DE	
4	164	DDA400AL164TTMA-DE	



TTMA Flange x Adaptor

## Dust Caps for Adaptors

Size (inch)	Body Size (mm)	Composite
		Part No.
¾ & 1	56	DDDC075-DE
1½ & 2	70	DDDC150-DE
3	105	DDDC300105-DE
3	119	DDDC300-DE
4	164	DDDC400-DE
6	238	DDDC600-DE <sup>1</sup>



Composite Dust Cap

<sup>1</sup> 6" dust plug is aluminium.

# Dry Disconnect Fittings

## Dry Aviation - Hose Unit Coupler



Female Thread x Coupler

<b>Application:</b>	<ul style="list-style-type: none"> <li>Dry aviation couplings are designed for use in aviation and military refueling systems.</li> </ul>
<b>Design:</b>	<ul style="list-style-type: none"> <li>Not configured for under wing refuelling. Riveted piston pin minimises the risk of failure under extreme pressure conditions</li> </ul>
<b>Materials:</b>	<ul style="list-style-type: none"> <li>Coupling ring: gunmetal</li> <li>Bayonet flange and inner parts: stainless steel and aluminium</li> <li>Stainless steel ball bearings</li> <li>Gunmetal coupling ring minimises the risk of seizure</li> <li>Stainless steel shaft journal embedded in PTFE to eliminate seizure</li> <li>PTFE bearings between the driving plate and the piston guide eliminates the risk of seizure</li> <li>Plugs in composite, provide very good protection against corrosion and withstand both hot and cold environments</li> <li>The protective ring is a specially formulated weather-resistant and electrically conductive rubber compound</li> </ul>
<b>Approvals:</b>	<ul style="list-style-type: none"> <li>Manufactured to accept international standard 2½" point bayonet, hose end refuelling nozzles according to: ISO45 / MS24484 / STANAG3105 / British Aerospace Spec. 2C14.</li> </ul>
<b>Working Pressure:</b>	<ul style="list-style-type: none"> <li>150 PSI</li> </ul>

### Couplers x Female NPT with FKM Seals

Female NPT (inch)	Body Size	Material	Part No.
2½	ISO 45	Aluminium	DAC250AL-DE
3	ISO 45	Aluminium	DAC300AL-DE

### Couplers x Female BSP with FKM Seals

Female BSP (inch)	Body Size	Material	Part No.
2½	ISO 45	Aluminium	DAC250ALBSP-DE
3	ISO 45	Aluminium	DAC300ALBSP-DE

## Dry Aviation - Sight Flow Indicator with Filter / Screen



<b>Design:</b>	<ul style="list-style-type: none"> <li>Filter / screen can be inspected through the sight glass and is easily removed if cleaning is required.</li> </ul>
<b>Material:</b>	<ul style="list-style-type: none"> <li>Screen - 100 mesh</li> </ul>

Female Thread (inch)	Male Thread (inch)	Material	Part No.
2½ NPT	2½ BSP	Aluminium	ASF125T25B-DE
3 NPT	3 BSP	Aluminium	ASF130T30B-DE
2½ NPT	2½ NPT	Aluminium	ASF125T25T-DE
3 NPT	3 NPT	Aluminium	ASF130T30T-DE

## Dry Aviation Dust Plug for Couplers



Size (inch)	Body Size (mm)	Composite
		Part No.
2½ and 3	ISO 45	DADP250-DE

## Dry Aviation - Tank Unit Adaptor

<b>Application:</b>	<ul style="list-style-type: none"> <li>Dry Aviation couplings are designed for use in aviation and military refuelling systems.</li> </ul>
<b>Design:</b>	<ul style="list-style-type: none"> <li>Not configured for under wing refuelling.</li> </ul>
<b>Materials:</b>	<ul style="list-style-type: none"> <li>Body: high-strength aluminium</li> <li>Coupling ring: gunmetal</li> <li>Bayonet flange and inner parts: stainless steel and aluminium</li> <li>All wetted parts are in aluminium and stainless steel</li> <li>Gunmetal coupling ring minimises the risk of seizure</li> <li>PTFE bearings between the piston shaft and the piston guide eliminate the risk of seizure</li> <li>Conical valve seat eliminates the risk of piston blowout when extreme pressure is used</li> <li>Composite cap provides good protection against corrosion and can withstand both hot and cold environments</li> </ul>
<b>Approvals:</b>	<ul style="list-style-type: none"> <li>Manufactured to accept international standard 2½" point bayonet, hose end refuelling nozzles according to: ISO45 / MS24484 / STANAG3105 / British Aerospace Spec. 2C14.</li> </ul>
<b>Working Pressure:</b>	<ul style="list-style-type: none"> <li>150 PSI</li> </ul>

### Couplers x Female NPT with FKM Seals

Female NPT (inch)	Body Size (mm)	Material	Part No.
2½	ISO 45	Aluminium	DAA250AL-DE
3	ISO 45	Aluminium	DAA300AL-DE

### Adaptors x 150# ASA (ANSI) Flange with FKM Seals

150# Flange (inch)	Body Size (mm)	Material	Part No.
2½	ISO 45	Aluminium	DAA250ALFL-DE
3	ISO 45	Aluminium	DAA300ALFL-DE

Also available with 4" TTMA Flange

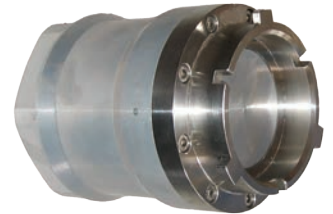

## Dry Aviation Dust Cap for Adaptors

Size (inch)	Body Size (mm)	Composite
		Part No.
2½ & 3	ISO 45	DADC250-DE



## Dry Disconnect Fittings for Steam Service

<b>Application:</b>	<ul style="list-style-type: none"> <li>Designed to fit hoses carrying steam used in chemical (heating), pharmaceutical (disinfection and sterilisation) and at loading bays</li> </ul>
<b>Material:</b>	<ul style="list-style-type: none"> <li>Coupling housing and all inner parts are stainless steel</li> <li>Seals are EPDM (standard); contact Dixon™ for other materials</li> </ul>
<b>Features:</b>	<ul style="list-style-type: none"> <li>Unintentional separation is eliminated, preventing accidents and avoiding unintended down time. Performance unaffected by surface rust. Lockable versions are available; contact Dixon™ for more information.</li> </ul>

Female NPT Size (inch)	Body Size (mm)	Part No.
<b>Stainless Steel Coupler</b>		
¾	56	DDSC075SS-DE
1	56	DDSC100SS-DE
1½	70	DDSC150SS-DE
2	70	DDSC200SS-DE
<b>Stainless Steel Adaptor</b>		
¾	56	DDSA075SS-DE
1	56	DDSA100SS-DE
1½	70	DDSA150SS-DE
2	70	DDSA200SS-DE



Coupler



Adaptor

# Dry Disconnect Fittings

## Dry Gas Couplings

<b>Application:</b>	<ul style="list-style-type: none"> <li>Dry gas couplings are designed for safe loading and discharge of bobtails or intermediate bulk delivery trucks. They are quick and easy to connect and can be connected to a tank unit with pressures up to <b>225 PSI</b>. If the pressure is higher you can equip the couplings with a pressure relief valve. The easy-to-connect pressure relief valve dissipates trapped fluid pressure into the hose coupler without spillage. The primary application of dry gas couplings is in the handling of LPG - propane and butane.</li> </ul>
<b>Design:</b>	<ul style="list-style-type: none"> <li>Safe handling of LPG</li> <li>Easy to use and saves time</li> <li>Reliable and easy to maintain</li> <li>Can be coupled against higher pressure</li> <li>Minimises the risk of cold burns</li> <li>Minimises spillage and product loss</li> <li>Minimises health risks</li> <li>Keeps the environment free of hazardous vapours and liquids</li> <li>Compatible with existing dry disconnect couplings</li> </ul>
<b>Materials:</b>	<ul style="list-style-type: none"> <li>Stainless steel and brass / gunmetal</li> <li>NBR90 seals</li> <li>Female NPT and ASA (ANSI) flanges</li> <li>Caps and plugs in composite provide a very good protection against corrosion and withstand both hot and cold environments</li> </ul>
<b>Working Pressure:</b>	<b>360 PSI</b>

Couplers x Female NPT with NBR90 Seals (Hose Unit)			
Female NPT (inch)	Body Size (mm)	Material	Part No.
1	56	Stainless Steel	DGC100SS-DE
2	71	Stainless Steel	DGC200SS-DE
3	119	Stainless Steel	DGC300SS-DE

Composite Dust Plug for Couplers			
Size (inch)	Body Size (mm)	Material	Part No.
1	56	Composite	DGDP100-DE
3	119	Composite	DGDP300-DE

Adaptors x Female NPT with NBR90 Seals (Tank Unit)			
Female NPT (inch)	Body Size (mm)	Material	Part No.
1	56	Stainless Steel	DGA100SS-DE
2	71	Stainless Steel	DGA200SS-DE
3	119	Stainless Steel	DGA300SS-DE

Adaptors x Female ACME Thread with FKM Seals			
Female ACME (inch)	Body Size (mm)	Material	Part No.
1¼	56	Stainless Steel	DGA100SS175-DE
3¼	71	Stainless Steel	DGA200SS325-DE

Adaptors x 150# ASA (ANSI) Flange with NBR90 Seals (Tank Unit)			
150# Flange (inch)	Body Size (mm)	Material	Part No.
1	56	Stainless Steel	DGA100SSFL-DE
2	71	Stainless Steel	DGA200SSFL-DE
3	119	Stainless Steel	DGA300SSFL-DE

Rubber Dust Cap for Adaptors			
Size (inch)	Body Size (mm)	Material	Part No.
1	56	Rubber	DGDC100-DE
2	71	Rubber	DGDC200-DE
3	119	Rubber	DGDC300-DE

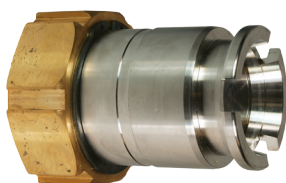

# Dry Disconnect Fittings

## Dry Break Cam & Groove Dry Disconnect Couplings - Couplers <sup>1</sup>

<b>Application:</b>	• Fully interchangeable with Kamvalok (OPW trademark) style fittings
<b>Design:</b>	• Dixon™ EZ Boss-Lock™ cam arms standard on all 1½" and 2" fittings provide high security from accidental opening due to vibration or snagging. Large paddle type locking cam arms standard on 3" fittings, allowing for an easy grip. Dry disconnect coupler has automatic closing poppet assembly. Strong handle attachment prevents bending of crank assembly
<b>Materials:</b>	• Heavy-duty stainless steel crank and link • Stainless steel investment cast handles • Aluminium fittings have stainless steel <sup>3</sup> internals

Female NPT (inch)	Coupler Size (inch)	Seal Material	Part No. <sup>4</sup>
<b>Aluminium</b>			
1½	2	Buna	DBC61-150
2	2½	Buna	DBC61-200
3	4	Buna	DBC61-300
1½	2	FKM	DBC62-150
2	2½	FKM	DBC62-200
3	4	FKM	DBC62-300
1½	2	PTFE Encapsulated Silicone and FFPM	DBC63-150
2	2½	PTFE Encapsulated Silicone and FFPM	DBC63-200
3	4	PTFE Encapsulated Silicone and FFPM	DBC63-300
1½	2	EPT	DBC64-150
2	2½	EPT	DBC64-200
3	4	EPT	DBC64-300
2	2½	FFPM and PTFE <sup>2</sup>	DBC66-200
3	4	FKM/B	DBC69-300
<b>Stainless Steel <sup>3</sup></b>			
1½	2	Buna	DBC71-150
2	2½	Buna	DBC71-200
3	4	Buna	DBC71-300
1½	2	FKM	DBC72-150
2	2½	FKM	DBC72-200
3	4	FKM	DBC72-300
1½	2	PTFE Encapsulated Silicone and FFPM	DBC73-150
2	2½	PTFE Encapsulated Silicone and FFPM	DBC73-200
3	4	PTFE Encapsulated Silicone and FFPM	DBC73-300
1½	2	EPT	DBC74-150
2	2½	EPT	DBC74-200
3	4	EPT	DBC74-300
1½	2	FFPM and PTFE <sup>2</sup>	DBC76-150
2	2½	FFPM and PTFE <sup>2</sup>	DBC76-200
3	4	FFPM and PTFE <sup>2</sup>	DBC76-300
1½	2	PTFE Encapsulated FKM and FFPM	DBC77-150
2	2½	PTFE Encapsulated FKM and FFPM	DBC77-200
3	4	PTFE Encapsulated FKM and FFPM	DBC77-300
3	4	FKM/B	DBC79-300

### Greaseless Coupler x Female NPT (Stainless Steel)

Female NPT (inch)	Coupler Size (inch)	Seal Material	Part No. <sup>4</sup>
1½	2	PTFE Encapsulated FKM and FFPM	DBC77-150-GL
2	2½	PTFE Encapsulated FKM and FFPM	DBC77-200-GL

### Coupler x 90° Swivel Female NPT (Aluminium)

Female NPT (inch)	Coupler Size (inch)	Seal Material	Part No. <sup>4</sup>
2	2½	Buna	DBS61-200
2	2½	FKM	DBS62-200
2	2½	PTFE Encapsulated Silicone and FFPM	DBS63-200

## Dust Plugs for Couplers

Size (inch)	Aluminium Part No.
2	ALDC200DP
2½	ALDC250DP
4	ALDC400DP

## Locking Kit for Couplers

Description	Material	Part No.
For use with 1½" & 2" dry disconnect couplers	Aluminium	DBCL-200
For use with 3" dry disconnect couplers	Aluminium	DBCL-300

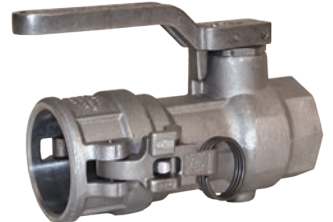

1½" & 2" Coupler x Female NPT



3" Coupler x Female NPT

- <sup>1</sup> A DBA style adaptor is required for coupler to operate. Adaptor sold separately.
- <sup>2</sup> FFPM gasket, main seal O-ring and handle O-ring. PTFE seals on cylinder assembly, stuffing box, and seal under poppet screw.
- <sup>3</sup> Stainless steel corrosion resistance is equivalent to 304 stainless steel.
- <sup>4</sup> Available in BSP upon request.

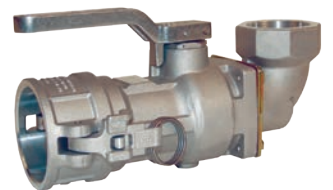

**NOTE:** Must be used with a DBA style adaptor for coupler to operate. Adaptor sold separately.



## Dry Break Cam & Groove Dry Disconnect Couplings - Adaptors

<b>Application:</b>	<ul style="list-style-type: none"> <li>Compatible with most cam &amp; groove style dry disconnects. Fully interchangeable with Kamvalok (OPW trademark) style fittings</li> </ul>
<b>Design:</b>	<ul style="list-style-type: none"> <li>The Bayco™ dry disconnect helps prevent spillage from normal or accidental disconnects. It has a spring-loaded sealing device designed to "snap" closed should the valve become disconnected with the poppet open, significantly limiting liquid loss.</li> <li>Two-piece adaptor design for easy rebuilding of adaptors</li> </ul>
<b>Material:</b>	<ul style="list-style-type: none"> <li>Aluminium fittings have aluminium nose piece and brass piston</li> </ul>

### Adaptor x Female NPT

Female NPT (inch)	Adaptor Size (inch)	Seal Material	Part No. <sup>2</sup>
<b>Aluminium</b>			
1½	2	Buna	DBA11-150
2	2½	Buna	DBA11-200
3	4	Buna	DBA11-300
1½	2	FKM	DBA12-150
2	2½	FKM	DBA12-200
3	4	FKM	DBA12-300
1½	2	PTFE Encapsulated Silicone	DBA63-150
2	2½	PTFE Encapsulated Silicone	DBA63-200
3	4	PTFE Encapsulated Silicone	DBA63-300
1½	2	EPT	DBA64-150
2	2½	EPT	DBA64-200
3	4	EPT	DBA64-300
1½	2	FFPM	DBA66-150
2	2½	FFPM	DBA66-200
3	4	FFPM	DBA66-300
3	4	PTFE Encapsulated FKM	DBA69-300
<b>Stainless Steel <sup>1</sup></b>			
1½	2	Buna	DBA71-150
2	2½	Buna	DBA71-200
3	4	Buna	DBA71-300
1½	2	FKM	DBA72-150
2	2½	FKM	DBA72-200
3	4	FKM	DBA72-300
1½	2	PTFE Encapsulated Silicone	DBA73-150
2	2½	PTFE Encapsulated Silicone	DBA73-200
3	4	PTFE Encapsulated Silicone	DBA73-300
1½	2	EPT	DBA74-150
2	2½	EPT	DBA74-200
3	4	EPT	DBA74-300
1½	2	FFPM	DBA76-150
2	2½	FFPM	DBA76-200
3	4	FFPM	DBA76-300
1½	2	PTFE Encapsulated FKM	DBA77-150
2	2½	PTFE Encapsulated FKM	DBA77-200
3	4	PTFE Encapsulated FKM	DBA77-300

<sup>1</sup> Stainless steel corrosion resistance is equivalent to 304 stainless steel

<sup>2</sup> Available in BSP upon request.

Note: Contact Dixon™ for compatibility, size, and material selection.

**Special configurations can be designed for your application.**



### Adaptor x 150# ASA Flange (Stainless Steel)

Flange Size (inch)	Adaptor Size (inch)	Seal Material	Part No.
2	2	FKM	DBAF72-1520
2	2½	FKM	DBAF72-200
3	4	FKM	DBAF72-300
2	2	PTFE Encapsulated Silicone	DBAF73-1520
2	2½	PTFE Encapsulated Silicone	DBAF73-200
3	4	PTFE Encapsulated Silicone	DBAF73-300
2	2	EPT	DBAF74-1520
2	2½	EPT	DBAF74-200
3	4	EPT	DBAF74-300
2	2	FFPM	DBAF76-1520
2	2½	FFPM	DBAF76-200
3	4	FFPM	DBAF76-300

### Vapour Adaptor x Female Thread (Stainless Steel)

Adaptor Size (inch)	Female Thread Size (inch)	Seal Material	Max PSI	Part No.
3	2	PTFE	150	DBAV73-2030

## Dust Caps for Adaptors



Size (inch)	Aluminium Part No.
2	ALDC200DC
2½	ALDC250DC
4	ALDC400DC

## Bayonet Style

<b>Application:</b>	<ul style="list-style-type: none"> <li>For the spill-less transfer of petroleum products such as fuel oil, lube oil blending, and tank truck delivery</li> </ul>
<b>Features:</b>	<ul style="list-style-type: none"> <li>Ensures a spill-free connection; fluid cannot flow until couplings are connected together and valve is opened; coupling can then not be disconnected until the valve handle is closed</li> <li>Swivels have a standard ZERK fittings</li> <li>Maximum operating pressure: <b>85 PSI @ 21°C (70°F)</b>, for pressure ratings at other temperatures contact Dixon™</li> <li>Replacement parts available; contact Dixon™ for more information</li> </ul>

90° Swivel Coupler x Female NPT			
Size (inch)	Seal Material	Material	Part No.
2	Buna	Anodized Hard Coat Aluminium	BS61-200
2	FKM	Anodized Hard Coat Aluminium	BS62-200
3	Buna	Anodized Hard Coat Aluminium	BS61-300
3	FKM	Anodized Hard Coat Aluminium	BS62-300



Straight Coupler x Female NPT			
Size (inch)	Seal Material	Material	Part No.
2	Buna	Anodized Hard Coat Aluminium	BC61-200
2	FKM	Anodized Hard Coat Aluminium	BC62-200



Straight Swivel Coupler x Female NPT			
Size (inch)	Seal Material	Material	Part No.
2	Buna	Anodized Hard Coat Aluminium	BSS61-200
2	FKM	Anodized Hard Coat Aluminium	BSS62-200
3	Buna	Anodized Hard Coat Aluminium	BSS61-300
3	FKM	Anodized Hard Coat Aluminium	BSS62-300



Dust Plugs			
Size (Inch)	Material	Part No.	
2	Rubber with Stainless Steel Chain	BCP-200	
3	Rubber with Stainless Steel Chain	BCP-300	



Adaptor x Female NPT				
Size (inch)	Seal Material	Stainless Steel Part No.	Brass Part No.	Aluminium Part No.
2	Buna	BA31-200	---	---
2	FKM	BA32-200	---	---
3	Buna	---	BA31-300	BA61-300
3	FKM	---	BA32-300	BA62-300



Dust Caps			
Size (inch)	Material	Part No.	
2	Rubber with Stainless Steel Chain	BAC-200	
3	Rubber with Stainless Steel Chain	BAC-300	





E

J-Series.....	167-169
N-Series .....	170-175
P-Series .....	176-178
NK-Series .....	179-180
DF-Series.....	181-186
H-Series .....	187-191
H-BOP Series .....	192
HS-Series.....	193-196
K-Series .....	197-200
W-Series .....	201-204
WS-Series.....	205-210
VEP-Series .....	211-215
HT-Series .....	216-222
HTE-Series .....	223-225
ST-Series .....	226-229
AG-Series .....	230-232
T-Series.....	233-234
TR-Series.....	235-237
E-Series .....	238-242
V-Series .....	243-253
CVV-Series .....	254-255
PD-Series.....	256-257





## J-Series Truflate Interchange

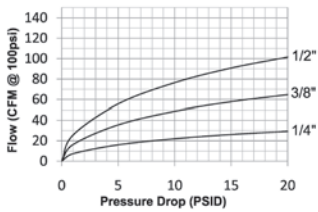

<b>Materials:</b>	<ul style="list-style-type: none"> <li>Machined components are manufactured using solid steel or brass bar stock</li> <li>Stainless steel balls, retaining rings, and springs maximise corrosion resistance and extend service life</li> <li>Steel componentry is plated using ROHS-compliant trivalent chrome</li> <li>1/4" couplers constructed of brass with steel sleeve and steel tubular valve as standard</li> <li>3/8" and 1/2" couplers constructed of steel as standard with steel tubular valves</li> </ul>
<b>Seal Components:</b>	<ul style="list-style-type: none"> <li>Nitrile (Buna-N) seals are standard, temperature range -40°C to 121°C (-40°F to 249°F)</li> </ul>
<b>Interchange Data:</b>	<ul style="list-style-type: none"> <li>Truflate automotive interchange style</li> <li>Parker 10-Series</li> <li>Rectus 55KM</li> <li>Tomco A2100/PT400</li> <li>Ryco 200</li> </ul>

Body Size (inch)	Brass Coupler / Steel Plug				Brass Coupler / Plug				Steel Coupler / Plug				303 Stainless Steel Coupler / Plug			
	Max Working		Coupled Burst		Max Working		Coupled Burst		Max Working		Coupled Burst		Max Working		Coupled Burst	
	PSI	bar	PSI	bar	PSI	bar	PSI	bar	PSI	bar	PSI	bar	PSI	bar	PSI	bar
1/4	500	35	11,500	793	300	20	10,500	724	-	-	-	-	-	-	-	-
3/8	-	-	-	-	-	-	-	-	500	35	18,000	1241	-	-	-	-
1/2	-	-	-	-	-	-	-	-	500	35	10,000	690	-	-	-	-

Size (inch)	Interchange Standards				Functional Parameters				
	US Military	US Government	International Standards	ANSI/NFPA Standards	Locking Ball Quantity	Air Inclusion	Fluid Loss	Vacuum Rating	Flow ΔP = 15 PSI
1/4	-	-	-	-	6	N/A	N/A	N/R	26 CFM
3/8	-	-	-	-	6	N/A	N/A	N/R	58 CFM
1/2	-	-	-	-	6	N/A	N/A	N/R	91 CFM

## J-Series Truflate Interchange Coupler

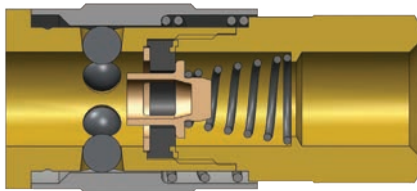

Female Thread

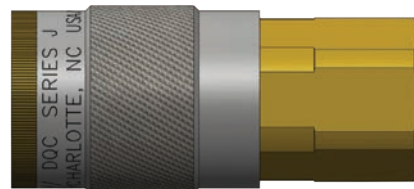

Body Size (inch)	Part No.	Threads	Material	Length		Maximum OD		Hex (inch)	Weight (kg)	Pkg Qty	
				inch	mm	inch	mm			Bag	Box
1/4	2JF1-B	1/8 - 27 NPTF	Brass	1.83	46.5	0.88	22.4	3/4	0.09	10	100
1/4	2JF2-B	1/4 - 18 NPTF	Brass	2.04	51.8	0.88	22.4	3/4	0.09	10	100
1/4	2JF3-B	3/8 - 18 NPTF	Brass	2.14	54.4	0.88	22.4	13/16	0.09	10	100
3/8	3JF3	3/8 - 18 NPTF	Steel	2.48	63.0	1.06	26.9	7/8	0.13	10	50
3/8	3JF4	1/2 - 14 NPTF	Steel	2.61	66.3	1.06	26.9	1	0.21	10	50
1/2	4FF3	3/8 - 18 NPTF	Steel	2.85	72.5	1.24	31.4	1	0.21	5	30
1/2	4FF4	1/2 - 14 NPTF	Steel	3.06	77.8	1.24	31.4	1	0.25	5	30
1/2	4FF6	3/4 - 14 NPTF	Steel	3.15	79.9	1.24	31.4	1 1/16	0.28	5	30

Operating pressure for couplings utilising hose barb end connections may be dramatically reduced to that of the hose rating and/or hose end connection combination. Consult hose manufacturer's catalogue for hose end connection ratings. If in doubt, test under controlled conditions for suitability to application. Dixon™ cannot assume liability for misapplication of production resulting in equipment down-time, lost production, and/or personal injury including death.

## J-Series Truflate Interchange Coupler

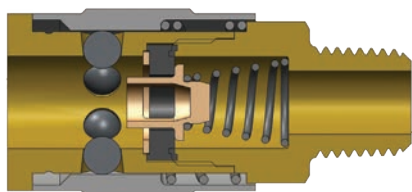

Male Thread

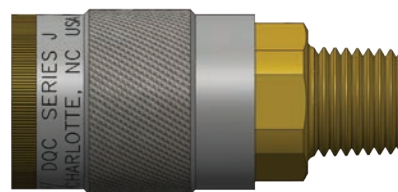

Body Size (inch)	Part No.	Threads	Material	Length		Maximum OD		Hex (inch)	Weight (kg)	Pkg Qty	
				inch	mm	inch	mm			Bag	Box
¼	2JM1-B	⅜ - 27 NPTF	Brass	1.88	47.8	0.88	22.4	¾	0.08	10	100
¼	2JM2-B	¼ - 18 NPTF	Brass	2.04	52.0	0.88	22.4	¾	0.08	10	100
¼	2JM3-B	⅝ - 18 NPTF	Brass	2.08	52.8	0.88	22.4	¾	0.08	10	100
⅜	3JM2	¼ - 18 NPTF	Steel	2.45	62.2	1.06	26.9	⅞	0.12	10	50
⅜	3JM3	⅝ - 18 NPTF	Steel	2.46	62.5	1.06	26.9	⅞	0.12	10	50
⅜	3JM4	½ - 14 NPTF	Steel	2.55	64.8	1.06	26.9	⅞	0.13	10	50
½	4FM3	⅝ - 18 NPTF	Steel	2.97	75.4	1.19	30.2	1	0.19	5	30
½	4FM4	½ - 14 NPTF	Steel	3.07	78.0	1.19	30.2	1	0.20	5	30
½	4FM6	¾ - 14 NPTF	Steel	3.12	79.2	1.19	30.2	1⅛	0.22	5	30

## E J-Series Truflate Interchange Nipple

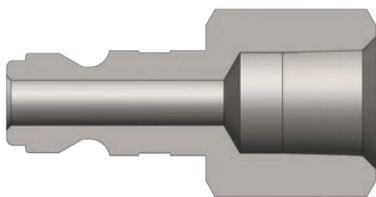

Female Thread

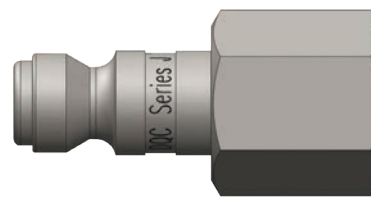

Body Size (inch)	Part No.	Threads	Material	Length		Maximum OD		Hex (inch)	Weight (kg)	Pkg Qty	
				inch	mm	inch	mm			Bag	Box
¼	J2F1	⅜ - 27 NPTF	Steel	1.34	34.0	0.65	16.5	⅞	0.02	10	100
¼	J2F2	¼ - 18 NPTF	Steel	1.56	39.6	0.79	20.1	1⅛	0.02	10	100
¼	J2F2-B	¼ - 18 NPTF	Brass	1.56	39.6	0.79	20.1	1⅛	0.02	10	100
¼	J2F3	⅝ - 18 NPTF	Steel	1.56	39.6	1.01	25.7	⅞	0.03	10	100
⅜	J3F3	⅝ - 18 NPTF	Steel	1.75	44.5	1.01	25.7	⅞	0.04	10	50
⅜	J3F4	½ - 14 NPTF	Steel	1.91	48.5	1.16	29.5	1	0.05	10	50
½	J4F3	⅝ - 18 NPTF	Steel	2.11	53.6	1.01	25.7	⅞	0.06	10	50
½	J4F4	½ - 14 NPTF	Steel	2.26	57.4	1.16	29.5	1	0.08	10	50
½	J4F6	¾ - 14 NPTF	Steel	2.31	58.7	1.37	34.8	1⅜	0.12	10	50

## J-Series Profiles

Body Size (inch)	A (mm)	B (mm)
¼	9.53	1.59
⅜	11.11	3.18
½	14.29	3.18

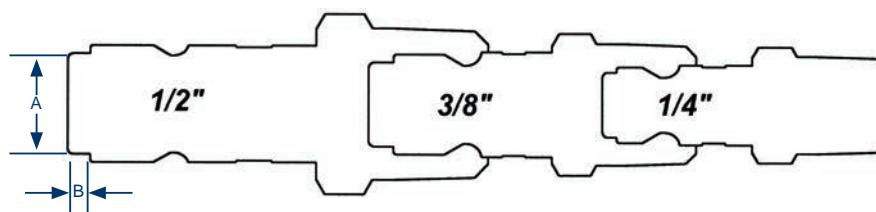

FOR TECHNICAL GUIDELINES PLEASE REFER TO PAGE 167

## J-Series Truflate Interchange Nipple

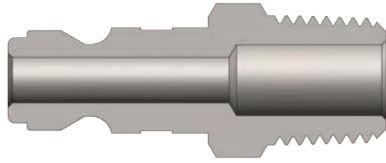

Male Thread



Body Size (inch)	Part No.	Threads	Material	Length		Maximum OD		Hex (inch)	Weight (kg)	Pkg Qty	
				inch	mm	inch	mm			Bag	Box
¼	J2M1	¼ - 27 NPTF	Steel	1.47	37.3	0.58	14.7	½	0.02	10	100
¼	J2M2	¼ - 18 NPTF	Steel	1.59	40.4	0.65	16.5	⅝	0.02	10	100
¼	J2M2-B	¼ - 18 NPTF	Brass	1.59	40.4	0.65	16.5	⅝	0.02	10	100
¼	J2M3	¾ - 18 NPTF	Steel	1.65	41.9	0.79	20.1	11/16	0.02	10	100
⅜	J3M3	¾ - 18 NPTF	Steel	1.84	46.7	0.79	20.1	11/16	0.04	10	50
⅜	J3M4	½ - 14 NPTF	Steel	2.00	50.8	1.01	25.7	7/8	0.05	10	50
½	J4M3	¾ - 18 NPTF	Steel	2.20	55.9	0.79	20.1	11/16	0.06	10	50
½	J4M4	½ - 14 NPTF	Steel	2.35	59.7	1.01	25.7	7/8	0.07	10	50
½	J4M6	¾ - 14 NPTF	Steel	2.51	63.8	1.23	31.2	1 1/16	0.11	10	50

## J-Series Truflate Interchange Coupler

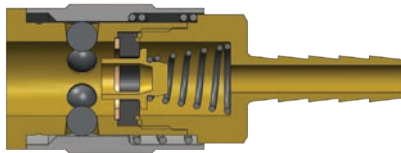

Standard Hose Barb

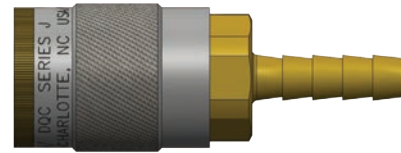

Body Size (inch)	Part No.	Hose ID (inch)	Material	Length		Maximum OD		Hex (inch)	Weight (kg)	Pkg Qty	
				inch	mm	inch	mm			Bag	Box
¼	2JS2-B	¼	Brass	2.53	64.3	0.88	22.4	¾	0.08	10	100
¼	2JS3-B	⅜	Brass	2.53	64.3	0.88	22.4	¾	0.08	10	100
⅜	3JS2	¼	Steel	2.86	72.6	1.06	26.9	7/8	0.12	10	50
⅜	3JS4	½	Steel	2.86	72.6	1.06	26.9	7/8	0.12	10	50
½	4FS3	⅜	Steel	3.49	88.6	1.19	30.2	1	0.18	5	30
½	4FS4	½	Steel	3.49	88.6	1.19	30.2	1	0.19	5	30
½	4FS6	¾	Steel	3.49	88.6	1.19	30.2	1	0.21	5	30

## J-Series Truflate Interchange Nipple

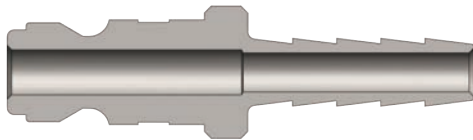

Standard Hose Barb

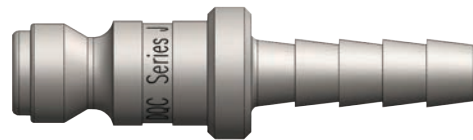

Body Size (inch)	Part No.	Hose ID (inch)	Material	Length		Maximum OD		Hex (inch)	Weight (kg)	Pkg Qty	
				inch	mm	inch	mm			Bag	Box
¼	J2S2	¼	Steel	1.99	50.5	0.56	14.2	-	0.02	10	100
¼	J2S3	⅜	Steel	1.99	50.5	0.56	14.2	-	0.02	10	100
⅜	J3S2	¼	Steel	2.18	55.4	0.75	19.1	-	0.03	10	50
⅜	J3S4	½	Steel	2.18	55.4	0.75	19.1	-	0.04	10	50
½	J4S3	⅜	Steel	2.54	64.5	0.75	19.1	-	0.03	10	50
½	J4S4	½	Steel	2.54	64.5	0.75	19.1	-	0.05	10	50
½	J4S6	¾	Steel	2.54	64.5	0.94	23.9	-	0.08	10	50

FOR TECHNICAL GUIDELINES PLEASE REFER TO PAGE 167

**N-Series Dix-Lock™**

<b>Application:</b>	<ul style="list-style-type: none"> <li>Used on large pneumatic hand-tools such as hammers, chippers, cable winders, air impact wrenches. Also widely used in refineries to convey air, water, and nitrogen, for military applications such as breathing air and fresh air systems, and on oil rigs for compression jacks and hand tools.</li> </ul>
<b>Materials:</b>	<ul style="list-style-type: none"> <li>Machined components are manufactured using solid steel, brass, or 303 stainless steel bar stock. 316 stainless steel available in some versions upon request</li> <li>Stainless steel retaining ring and spring maximise corrosion resistance and extend service life</li> <li>Steel componentry is plated using ROHS-compliant trivalent chrome</li> <li>Dust cap cable constructed of stainless steel</li> <li>Coupling sleeve constructed of cast zinc steel</li> <li>Steel and brass locking version have an aluminium lock ring while the stainless locking version has a stainless lock ring</li> </ul>
<b>Seal Components:</b>	<ul style="list-style-type: none"> <li>Nitrile (Buna-N) pneumatically energised seals are standard, temperature range <b>-40°C to 121°C (-40°F to 249°F)</b></li> </ul>
<b>Interchange Data:</b>	<ul style="list-style-type: none"> <li>Bowes Interchange Bayonet Style</li> <li>Interchangeable with Bowes 51000-Series, National Series 'B', MacDonald Quick-Action</li> <li>US Military MIL-C-3486 and US Government A-A50431A</li> </ul>

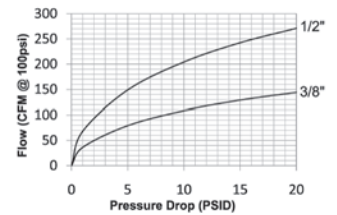
**N-Series Bowes Interchange**

Body Size (inch)	Steel Coupler / Plug				Brass Coupler / Plug				303 Stainless Steel Coupler / Plug			
	Max Working		Coupled Burst		Max Working		Coupled Burst		Max Working		Coupled Burst	
	PSI	bar	PSI	bar	PSI	bar	PSI	bar	PSI	bar	PSI	bar
3/8	500	35	7,000	480	-	-	-	-	-	-	-	-
1/2	500	35	11,000	755	300	20	8,200	565	500	35	12,600	869

E

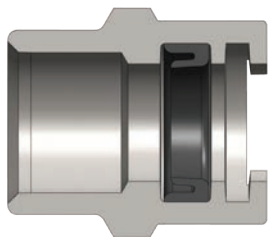
**N-Series Dix-Lock™ Coupler**

Female Thread

**N-Series Bowes Interchange Coupler**

Body Size (inch)	Part No.	Threads (inch)	Material	Length		Maximum OD		Hex Size (inch)	Weight (kg)	Pkg Qty	
				inch	mm	inch	mm			Bag	Box
1/2	4NF3	3/8 - 18 NPTF	Steel	1.63	41.4	1.54	39.1	1 1/8	0.23	-	25
1/2	4NF3-B	3/8 - 18 NPTF	Brass	1.63	41.4	1.54	39.1	1 1/8	0.25	-	25
1/2	4NBF3	3/8 - 19 BSPPF	Steel	1.63	41.4	1.54	39.1	1 1/8	0.23	-	25
1/2	4NF4	1/2 - 14 NPTF	Steel	1.63	41.4	1.54	39.1	1 1/8	0.21	-	25
1/2	4NF4-B	1/2 - 14 NPTF	Brass	1.63	41.4	1.54	39.1	1 1/8	0.23	-	25
1/2	4NBF4	1/2 - 14 BSPPF	Steel	1.63	41.4	1.54	39.1	1 1/8	0.21	-	25
1/2	4NBF4-B	1/2 - 14 BSPPF	Brass	1.63	41.4	1.54	39.1	1 1/8	0.23	-	25
1/2	4NF6	3/4 - 14 NPTF	Steel	1.63	41.4	1.54	39.1	1 1/8	0.16	-	25
1/2	4NF6-B	3/4 - 14 NPTF	Brass	1.63	41.4	1.54	39.1	1 1/8	0.19	-	25
1/2	4NF6-S	3/4 - 14 NPTF	303 SS	1.63	41.4	1.54	39.1	1 1/8	0.17	-	25
1/2	4NBF6	3/4 - 14 BSPPF	Steel	1.63	41.4	1.54	39.1	1 1/8	0.16	-	25
1/2	4NBF6-B	3/4 - 14 BSPPF	Brass	1.63	41.4	1.54	39.1	1 1/8	0.19	-	25
1/2	4NF8	1 - 11 1/2 NPTF	Steel	1.68	42.6	1.73	43.9	1 1/2	0.22	-	25
1/2	4NF8-B	1 - 11 1/2 NPTF	Brass	1.68	42.6	1.73	43.9	1 1/2	0.24	-	25
1/2	4NBF8	1 - 11 BSPPF	Steel	1.68	42.6	1.73	43.9	1 1/2	0.22	-	25
1/2	4NBF8-B	1 - 11 BSPPF	Brass	1.68	42.6	1.73	43.9	1 1/2	0.24	-	25



It is important to be safe when installing quick disconnect couplings into a pneumatic circuit. Never install a pneumatic coupling directly into an air tool. Use a piece of hose that is at least 18" long, between the tool and the coupling, to prevent damage to the coupling. To protect the operator, safety devices, such as a safety check valve and safety cable, should be installed in case there is a hose or coupling failure.

## N-Series Dix-Lock™ Nipple

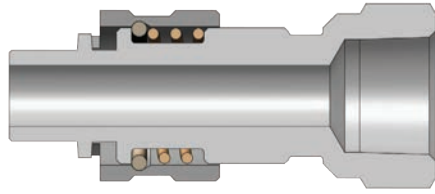

Female Thread



N-Series Bowes Interchange Nipple

Body Size (inch)	Part No.	Threads (inch)	Material	Length		Maximum OD		Hex Size (inch)	Weight (kg)	Pkg Qty	
				inch	mm	inch	mm			Bag	Box
½	N4F3	¾ - 18 NPTF	Steel	2.73	69.3	1.40	35.6	1½	0.22	-	25
½	N4F3-B	¾ - 18 NPTF	Brass	2.73	69.3	1.40	35.6	1½	0.24	-	25
½	N4BF3	¾ - 19 BSPPF	Steel	2.73	69.3	1.40	35.6	1½	0.22	-	25
½	N4F4	½ - 14 NPTF	Steel	2.73	69.3	1.40	35.6	1½	0.34	-	25
½	N4F4-B	½ - 14 NPTF	Brass	2.73	69.3	1.40	35.6	1½	0.38	-	25
½	N4BF4	½ - 14 BSPPF	Steel	2.73	69.3	1.40	35.6	1½	0.34	-	25
½	N4BF4-B	½ - 14 BSPPF	Brass	2.73	69.3	1.40	35.6	1½	0.38	-	25
½	N4F6	¾ - 14 NPTF	Steel	3.34	84.8	1.58	40.1	1½	0.30	-	25
½	N4F6-B	¾ - 14 NPTF	Brass	3.34	84.8	1.58	40.1	1½	0.34	-	25
½	N4F6-S	¾ - 14 NPTF	303 SS	3.34	84.8	1.58	40.1	1½	0.31	-	25
½	N4BF6	¾ - 14 BSPPF	Steel	3.34	84.8	1.58	40.1	1½	0.32	-	25
½	N4BF6-B	¾ - 14 BSPPF	Brass	3.34	84.8	1.58	40.1	1½	0.34	-	25
½	N4F8	1 - 11 ½ NPTF	Steel	3.37	85.7	1.73	43.9	1½	0.33	-	25
½	N4F8-B	1 - 11 ½ NPTF	Brass	3.37	85.7	1.73	43.9	1½	0.35	-	25
½	N4BF8	1 - 11 BSPPF	Steel	3.37	85.7	1.73	43.9	1½	0.33	-	25
½	N4BF8-B	1 - 11 BSPPF	Brass	3.37	85.7	1.73	43.9	1½	0.35	-	25

E

## N-Series Dix-Lock™ Safety-Lock Nipple

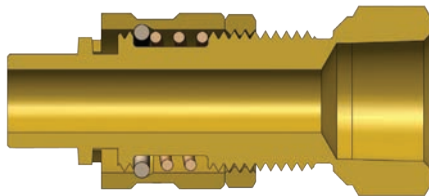

Female Thread



N-Series Bowes Interchange Safety-Lock Nipple

Body Size (inch)	Part No.	Threads (inch)	Material	Length		Maximum OD		Hex Size (inch)	Weight (kg)	Pkg Qty	
				inch	mm	inch	mm			Bag	Box
½	N4F4-B-LS	½ - 14 NPTF	Brass	4.28	108.6	1.58	40.1	1½	0.31	-	25
½	N4F6-B-LS	¾ - 14 NPTF	Brass	4.38	111.2	1.73	43.9	1½	0.30	-	25

FOR TECHNICAL GUIDELINES PLEASE REFER TO PAGE 170

# Hydraulic & Pneumatic

## N-Series Dix-Lock™ Coupler

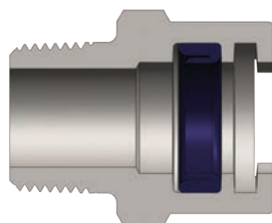

Male Thread



N-Series Bowes Interchange Coupler

Body Size (inch)	Part No.	Threads (inch)	Material	Length		Maximum OD		Hex Size (inch)	Weight (kg)	Pkg Qty	
				inch	mm	inch	mm			Bag	Box
3/8	3NM4	1/2 - 14 NPTM	Steel	1.72	43.6	1.37	34.8	1 3/16	0.09	-	40
3/8	3NBM4	1/2 - 14 BSPTM	Steel	1.72	43.6	1.37	34.8	1 3/16	0.09	-	40
1/2	4NM3	3/8 - 18 NPTM	Steel	1.77	45.0	1.54	39.1	1 3/8	0.14	-	25
1/2	4NM3-B	3/8 - 18 NPTM	Brass	1.77	45.0	1.54	39.1	1 3/8	0.15	-	25
1/2	4NBM3	3/8 - 19 BSPTM	Steel	1.77	45.0	1.54	39.1	1 3/8	0.14	-	25
1/2	4NM4	1/2 - 14 NPTM	Steel	1.77	45.0	1.54	39.1	1 3/8	0.15	-	25
1/2	4NM4-B	1/2 - 14 NPTM	Brass	1.77	45.0	1.54	39.1	1 3/8	0.16	-	25
1/2	4NBM4	1/2 - 14 BSPTM	Steel	1.77	45.0	1.54	39.1	1 3/8	0.15	-	25
1/2	4NBM4-B	1/2 - 14 BSPTM	Brass	1.77	45.0	1.54	39.1	1 3/8	0.16	-	25
1/2	4NM6	3/4 - 14 NPTM	Steel	1.77	45.0	1.54	39.1	1 3/8	0.15	-	25
1/2	4NM6-B	3/4 - 14 NPTM	Brass	1.77	45.0	1.54	39.1	1 3/8	0.17	-	25
1/2	4NM6-S	3/4 - 14 NPTM	303 SS	1.77	45.0	1.54	39.1	1 3/8	0.16	-	25
1/2	4NBM6	3/4 - 14 BSPTM	Steel	1.77	45.0	1.54	39.1	1 3/8	0.15	-	25
1/2	4NBM6-B	3/4 - 14 BSPTM	Brass	1.77	45.0	1.54	39.1	1 3/8	0.17	-	25
1/2	4NM8	1 - 11 1/2 NPTM	Steel	1.84	46.8	1.73	43.9	1 1/2	0.20	-	25
1/2	4NM8-B	1 - 11 1/2 NPTM	Brass	1.84	46.8	1.73	43.9	1 1/2	0.22	-	25
1/2	4NBM8	1 - 11 BSPTM	Steel	1.84	46.8	1.73	43.9	1 1/2	0.20	-	25
1/2	4NBM8-B	1 - 11 BSPTM	Brass	1.84	46.8	1.73	43.9	1 1/2	0.22	-	25

## N-Series Dix-Lock™ Nipple

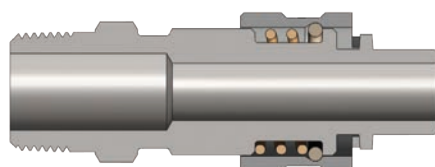

Male Thread



N-Series Bowes Interchange Nipple

Body Size (inch)	Part No.	Threads (inch)	Material	Length		Maximum OD		Hex Size (inch)	Weight (kg)	Pkg Qty	
				inch	mm	inch	mm			Bag	Box
3/8	N3M4	1/2 - 14 NPTM	Steel	1.72	43.6	1.37	34.8	1 3/16	0.18	-	40
3/8	N3BM4	1/2 - 14 BSPTM	Steel	1.72	43.6	1.37	34.8	1 3/16	0.18	-	40
1/2	N4M3	3/8 - 18 NPTM	Steel	3.65	92.7	1.40	35.6	1 3/8	0.24	-	25
1/2	N4M3-B	3/8 - 18 NPTM	Brass	3.65	92.7	1.40	35.6	1 3/8	0.25	-	25
1/2	N4BM3	3/8 - 19 BSPTM	Steel	3.65	92.7	1.40	35.6	1 3/8	0.24	-	25
1/2	N4M4	1/2 - 14 NPTM	Steel	3.65	92.7	1.40	35.6	1 3/8	0.27	-	25
1/2	N4M4-B	1/2 - 14 NPTM	Brass	3.65	92.7	1.40	35.6	1 3/8	0.28	-	25
1/2	N4BM4	1/2 - 14 BSPTM	Steel	3.65	92.7	1.40	35.6	1 3/8	0.27	-	25
1/2	N4BM4-B	1/2 - 14 BSPTM	Brass	3.65	92.7	1.40	35.6	1 3/8	0.29	-	25
1/2	N4M6	3/4 - 14 NPTM	Steel	3.74	95.0	1.40	35.6	1 3/8	0.27	-	25
1/2	N4M6-B	3/4 - 14 NPTM	Brass	3.74	95.0	1.40	35.6	1 3/8	0.29	-	25
1/2	N4M6-S	3/4 - 14 NPTM	303 SS	3.74	95.0	1.40	35.6	1 3/8	0.28	-	25
1/2	N4BM6	3/4 - 14 BSPTM	Steel	3.74	95.0	1.40	35.6	1 3/8	0.27	-	25
1/2	N4BM6-B	3/4 - 14 BSPTM	Brass	3.74	95.0	1.40	35.6	1 3/8	0.29	-	25
1/2	N4M8	1 - 11 1/2 NPTM	Steel	3.78	95.9	1.54	39.1	1 3/8	0.32	-	25
1/2	N4M8-B	1 - 11 1/2 NPTM	Brass	3.78	95.9	1.54	39.1	1 3/8	0.34	-	25
1/2	N4BM8	1 - 11 BSPTM	Steel	3.78	95.9	1.54	39.1	1 3/8	0.32	-	25
1/2	N4BM8-B	1 - 11 BSPTM	Brass	3.78	95.9	1.54	39.1	1 3/8	0.34	-	25

FOR TECHNICAL GUIDELINES PLEASE REFER TO PAGE 170

## N-Series Dix-Lock™ Safety-Lock Nipple

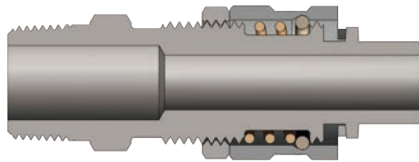

Male Thread



N-Series Bowes Interchange Safety-Lock Nipple

Body Size (inch)	Part No.	Threads (inch)	Material	Length		Maximum OD		Hex Size (inch)	Weight (kg)	Pkg Qty	
				inch	mm	inch	mm			Bag	Box
½	N4M4-LS	½ - 14 NPTM	Steel	3.65	92.7	1.40	35.6	1½	0.29	-	25
½	N4M4-B-LS	½ - 14 NPTM	Brass	3.65	92.7	1.40	35.6	1½	0.31	-	25
½	N4BM4-LS	½ - 14 BSPTM	Steel	3.65	92.7	1.40	35.6	1½	0.29	-	25
½	N4M6-LS	¾ - 14 NPTM	Steel	3.74	95.0	1.40	35.6	1½	0.29	-	25
½	N4M6-B-LS	¾ - 14 NPTM	Brass	3.74	95.0	1.40	35.6	1½	0.31	-	25
½	N4M6-S-LS	¾ - 14 NPTM	303 SS	3.74	95.0	1.40	35.6	1½	0.30	-	25
½	N4BM6-LS	¾ - 14 BSPTM	Steel	3.74	95.0	1.40	35.6	1½	0.29	-	25

## N-Series Dix-Lock™ Coupler

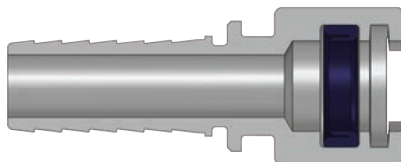

Hose Barb

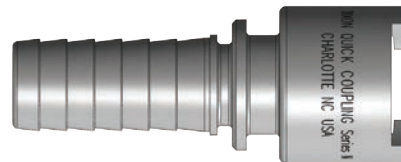

N-Series Bowes Interchange Coupler

Body Size (inch)	Part No.	Hose ID (inch)	Material	Length		Maximum OD		Hex Size (inch)	Weight (kg)	Pkg Qty	
				inch	mm	inch	mm			Bag	Box
¾	3NCS4	½	Steel	2.41	61.2	1.20	30.5	-	0.08	-	40
½	4NS3	¾	Steel	2.98	75.7	1.33	33.8	-	0.15	-	25
½	4NS3-B	¾	Brass	2.98	75.7	1.33	33.8	-	0.16	-	25
½	4NS4	½	Steel	3.37	85.6	1.33	33.8	-	0.16	-	25
½	4NS4-B	½	Brass	3.37	85.6	1.33	33.8	-	0.18	-	25
½	4NS6	¾	Steel	3.37	85.6	1.33	33.8	-	0.18	-	25
½	4NS6-B	¾	Brass	3.37	85.6	1.33	33.8	-	0.20	-	25
½	4NS6-S	¾	303 SS	3.37	85.6	1.33	33.8	-	0.19	-	25
½	4NS8	1	Steel	3.49	88.7	1.33	33.8	-	0.24	-	25
½	4NS8-B	1	Brass	3.49	88.7	1.33	33.8	-	0.25	-	25
½	4NS8-S	1	303 SS	3.49	88.7	1.33	33.8	-	0.25	-	25



FOR TECHNICAL GUIDELINES PLEASE REFER TO PAGE 170



+44 (0)1772 323529  
europe.dixonvalve.com  
sale@technobearing.ru

TECHNOBEARING.RU

DGEL2020  
8 (800) 700-72-07

# Hydraulic & Pneumatic

## N-Series Dix-Lock™ Nipple

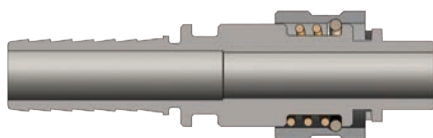

Hose Barb

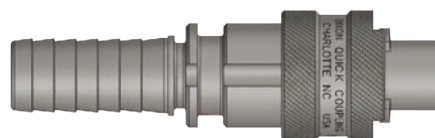

N-Series Bowes Interchange Nipple

Body Size (inch)	Part No.	Hose ID (inch)	Material	Length		Maximum OD		Hex Size (inch)	Weight (kg)	Pkg Qty	
				inch	mm	inch	mm			Bag	Box
3/8	N3CS4	1/2	Steel	3.73	94.8	1.13	28.6	-	0.15	-	40
1/2	N4S3	3/8	Steel	4.36	110.7	1.40	35.6	-	0.27	-	25
1/2	N4S3-B	3/8	Brass	4.36	110.7	1.40	35.6	-	0.30	-	25
1/2	N4S4	1/2	Steel	4.63	117.6	1.40	35.6	-	0.27	-	25
1/2	N4S4-B	1/2	Brass	4.63	117.6	1.40	35.6	-	0.30	-	25
1/2	N4S6	3/4	Steel	4.77	121.2	1.40	35.6	-	0.27	-	25
1/2	N4S6-B	3/4	Brass	4.77	121.2	1.40	35.6	-	0.29	-	25
1/2	N4S6-S	3/4	303 SS	4.77	121.2	1.40	35.6	-	0.28	-	25
1/2	N4S8	1	Steel	4.77	121.2	1.40	35.6	-	0.29	-	25
1/2	N4S8-B	1	Brass	4.77	121.2	1.40	35.6	-	0.31	-	25
1/2	N4S8-S	1	303 SS	4.77	121.2	1.40	35.6	-	0.31	-	25

E

## N-Series Dix-Lock™ Safety-Lock Nipple

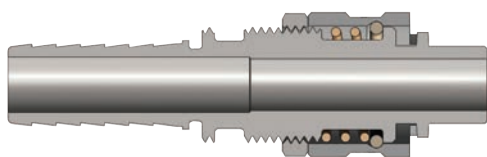

Hose Barb

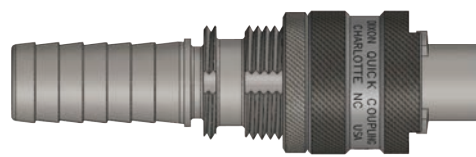

N-Series Bowes Interchange Safety-Lock Nipple

Body Size (inch)	Part No.	Hose ID (inch)	Material	Length		Maximum OD		Hex Size (inch)	Weight (kg)	Pkg Qty	
				inch	mm	inch	mm			Bag	Box
1/2	N4S4-LS	1/2	Steel	4.63	117.6	1.40	35.6	-	0.28	-	25
1/2	N4S4-B-LS	1/2	Brass	4.63	117.6	1.40	35.6	-	0.31	-	25
1/2	N4S6-LS	3/4	Steel	4.77	121.2	1.40	35.6	-	0.28	-	25
1/2	N4S6-B-LS	3/4	Brass	4.77	121.2	1.40	35.6	-	0.30	-	25
1/2	N4S6-S-LS	3/4	303 SS	4.77	121.2	1.40	35.6	-	0.29	-	25

## N-Series Dix-Lock™ Gender-Change Union

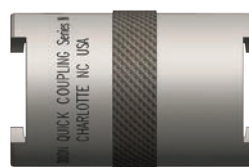
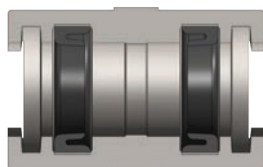

N-Series Bowes Interchange Gender-Change Union

Body Size (inch)	Part No.	Configuration	Material	Length		Maximum OD		Hex Size (inch)	Weight (kg)	Pkg Qty	
				inch	mm	inch	mm			Bag	Box
1/2	4N4N	coupler to coupler	Steel	3.26	82.80	1.33	33.80	-	0.14	-	25

FOR TECHNICAL GUIDELINES PLEASE REFER TO PAGE 170



## N-Series Dix-Lock™ Protective Nipple Cap



N-Series Bowes Interchange Protective Nipple Cap

Body Size (inch)	Part No.	Cap Lanyard	Material	Length		Maximum OD		Weight (kg)	Pkg Qty	
				inch	mm	inch	mm		Bag	Box
½	N4DC	SS Steel Cable	Steel	1.50	38.10	1.33	33.80	0.15	-	25
½	N4DC-B	SS Steel Cable	Brass	1.50	38.10	1.33	33.80	0.16	-	25

## N-Series Dix-Lock™ Replacement Seals

N-Series Bowes Interchange Replacement Seals

Body Size (inch)	Part No.	Coupler Style	Seal Material	Seal Kit Contents	Pkg Qty	
					Bag	Box
⅜	3N-SKIT	All	Nitrile	O-Ring	25	200
½	4N-SKIT	All	Nitrile	Pneumatically Energised Seal	25	200
½	F-4N-SKIT	All	FKM	Pneumatically Energised Seal	25	500



## N-Series Dix-Lock™ with Ferrules

**Application:**

• Dix-Lock™ with carbon steel ferrules can be crimped or swaged-on. For crimp or swage diameter recommendations refer to page 360. Rated to **150 PSI** working pressure.

Hose Shank (inch)	Body Size (inch)	Material	Hose OD (mm)		Part No.
			From:	To:	
<b>Male</b>					
½	½	Steel	21	26	N4S4-WF43
¾	½	Steel	29	34	N4S6-WF63
<b>Female</b>					
½	½	Steel	21	26	4NS4-WF43
¾	½	Steel	29	34	4NS6-WF63



Male Head



Female Head



FOR TECHNICAL GUIDELINES PLEASE REFER TO PAGE 170

# Hydraulic & Pneumatic

## P-Series Dual Lock™

<b>Applications:</b>	<ul style="list-style-type: none"> <li>Used on large pneumatic hand-tools such as hammers, chippers, cable winders, air impact wrenches. Also widely used in refineries to convey air, water, and nitrogen, for military applications such as breathing air and fresh air systems, and on oil rigs for compression jacks and hand tools.</li> </ul>
<b>Materials:</b>	<ul style="list-style-type: none"> <li>Machined components are manufactured using solid steel, brass, or 303 stainless steel bar stock</li> <li>Stainless steel retaining ring and spring maximise corrosion resistance and extend service life on the 1-piece sleeve. 2-piece sleeve has a phosphor bronze spring</li> <li>Steel componentry is plated using ROHS-compliant trivalent chrome</li> <li>Steel couplings have a zinc cast sleeve</li> </ul>
<b>Seal Components:</b>	<ul style="list-style-type: none"> <li>Nitrile (Buna-N) seals are standard-temperature range <b>-40°C to 121°C (-40°F to 249°F)</b></li> </ul>
<b>Interchange Data:</b>	<ul style="list-style-type: none"> <li>Thor Finger-Lock Interchange</li> <li>Interchanges with Thor PHC-Series, National Series 'A', Dual-Lock and Campbell Double Lock</li> </ul>

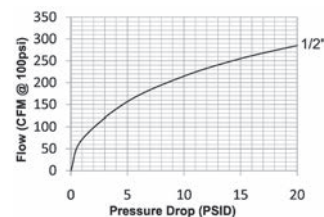

### P-Series Thor Interchange

Body Size (inch)	Steel Coupler / Plug				Brass Coupler / Plug				303 Stainless Steel Coupler / Plug			
	Max Working		Coupled Burst		Max Working		Coupled Burst		Max Working		Coupled Burst	
	PSI	bar	PSI	bar	PSI	bar	PSI	bar	PSI	bar	PSI	bar
½	300	20	2,600	180	300	20	3,500	240	300	20	4,500	310

### Interchange Standards

Size (inch)	Interchange Standards				Functional Parameters				
	US Military	US Government	International Standards	ANSI/NFPA Standards	Locking Mechanism	Air Inclusion	Fluid Loss	Vacuum Rating	Flow ΔP = 15 PSI
½	-	-	-	-	Latch Fingers	N/A	N/A	N/R	255 CFM

## P-Series Dual Lock Coupler

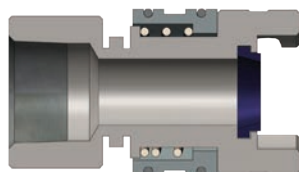

Female Thread

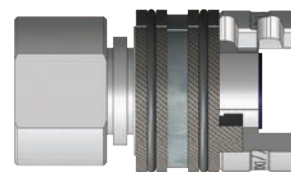

### P-Series Thor Interchange Coupler

Body Size (inch)	Part No.	Threads	Material	Length		Maximum OD		Wrench Flats (inch)	Weight (kg)	Pkg Qty	
				(inch)	mm	inch	mm			Bag	Box
½	4PF4	½" - 14 NPTF	Steel	2.75	69.9	1.55	39.4	1¼	0.29	-	25
½	4PF6	¾" - 14 NPTF	Steel	2.75	69.9	1.55	39.4	1¼	0.25	-	25
½	4PF6-B	¾" - 14 NPTF	Brass	2.75	69.9	1.55	39.4	1¼	0.26	-	25
½	4PF6-S	¾" - 14 NPTF	303 SS	2.75	69.9	1.55	39.4	1¼	0.26	-	25

## P-Series Dual Lock Nipple

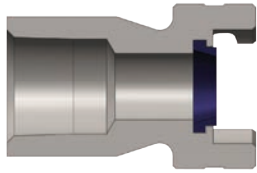

Female Thread

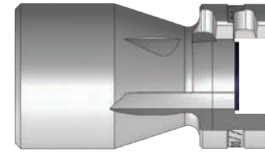

P-Series Thor Interchange Nipple

Body Size (inch)	Part No.	Threads	Material	Length		Maximum OD		Wrench Flats (inch)	Weight (kg)	Pkg Qty	
				inch	mm	inch	mm			Bag	Box
½	P4F3	⅜"-18 NPTF	Steel	1.79	45.5	1.55	39.4	⅞	0.22	-	25
½	P4F4	½"-14 NPTF	Steel	2.25	57.2	1.55	39.4	1⅛	0.34	-	25
½	P4F4-B	½"-14 NPTF	Brass	2.25	57.2	1.55	39.4	1⅛	0.38	-	25
½	P4F6	¾"-14 NPTF	Steel	2.34	59.4	1.55	39.4	1⅛	0.30	-	25
½	P4F6-9	¾"-14 NPTF	Steel/Tefcoat	2.34	59.4	1.55	39.4	1⅛	0.30	-	25
½	P4F6-B	¾"-14 NPTF	Brass	2.34	59.4	1.55	39.4	1⅛	0.34	-	25
½	P4F6-S	¾"-14 NPTF	303 Stainless	2.34	59.4	1.55	39.4	1⅛	0.31	-	25
½	P4F8	1"-11½ NPTF	Steel	2.76	70.1	1.55	39.4	1⅛	0.33	-	25
½	P4F8-B	1"-11½ NPTF	Brass	2.76	70.1	1.55	39.4	1⅛	0.35	-	25

## P-Series Dual Lock Coupler

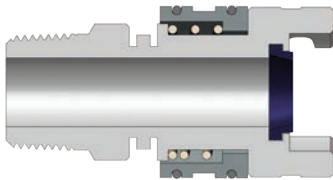

Male Thread

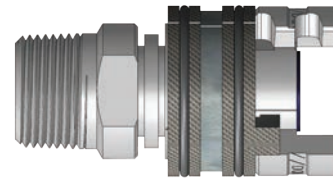

P-Series Thor Interchange Coupler

Body Size (inch)	Part No.	Threads	Material	Length		Maximum OD		Wrench Flats (inch)	Weight (kg)	Pkg Qty	
				inch	mm	inch	mm			Bag	Box
½	4PM3	⅜"-18 NPTM	Steel	2.93	74.4	1.55	39.4	⅞	0.22	-	25
½	4PM4	½"-14 NPTM	Steel	2.98	75.7	1.55	39.4	⅞	0.22	-	25
½	4PM6	¾"-14 NPTM	Steel	2.98	75.7	1.55	39.4	1⅛	0.23	-	25
½	4PM6-9	¾"-14 NPTM	Steel/Tefcoat	2.98	75.7	1.55	39.4	1⅛	0.23	-	25
½	4PM6-S	¾"-14 NPTM	303 Stainless	2.98	75.7	1.55	39.4	1⅛	0.23	-	25
½	4PM8	1"-11½ NPTM	Steel	3.11	79.0	1.55	39.4	1⅞	0.25	-	25

## P-Series Dual Lock Nipple

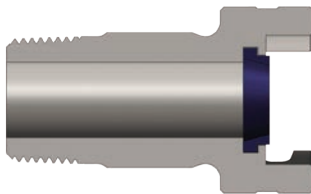

Male Thread

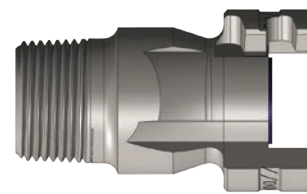

P-Series Thor Interchange Nipple

Body Size (inch)	Part No.	Threads	Material	Length		Maximum OD		Wrench Flats (inch)	Weight (kg)	Pkg Qty	
				inch	mm	inch	mm			Bag	Box
½	P4M3	⅜"-18 NPTM	Steel	2.00	50.8	1.55	39.4	⅞	0.13	-	25
½	P4M4	½"-14 NPTM	Steel	2.25	57.2	1.55	39.4	1⅛	0.15	-	25
½	P4M4-B	½"-14 NPTM	Brass	2.25	57.2	1.55	39.4	1⅛	0.16	-	25
½	P4M6	¾"-14 NPTM	Steel	2.55	64.8	1.55	39.4	1⅞	0.20	-	25
½	P4M6-9	¾"-14 NPTM	Steel/Tefcoat	2.55	64.8	1.55	39.4	1⅞	0.20	-	25
½	P4M6-B	¾"-14 NPTM	Brass	2.55	64.8	1.55	39.4	1⅞	0.22	-	25
½	P4M6-S	¾"-14 NPTM	303 SS	2.55	64.8	1.55	39.4	1⅞	0.21	-	25
½	P4M8	1"-11½ NPTM	Steel	3.25	82.6	1.55	39.4	1⅞	0.28	-	25
½	P4M8-B	1"-11½ NPTM	Brass	3.25	82.6	1.55	39.4	1⅞	0.30	-	25

FOR TECHNICAL GUIDELINES PLEASE REFER TO PAGE 176

# Hydraulic & Pneumatic

## P-Series Dual Lock Coupler

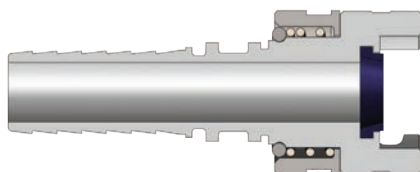

Hose Barb

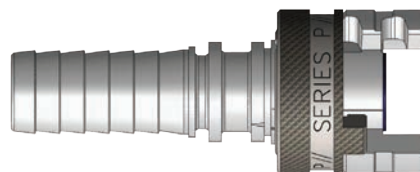

### P-Series Thor Interchange Coupler

Body Size (inch)	Part No.	Hose ID (inch)	Material	Length		Maximum OD		Hex Size (inch)	Weight (kg)	Pkg Qty	
				inch	mm	inch	mm			Bag	Box
½	4PS3	⅜	Steel	3.53	89.7	1.55	39.4	-	0.22	-	25
½	4PS4	½	Steel	3.95	100.3	1.55	39.4	-	0.24	-	25
½	4PS4-B	½	Brass	3.95	100.3	1.55	39.4	-	0.26	-	25
½	4PS6	¾	Steel	3.95	100.3	1.55	39.4	-	0.25	-	25
½	4PS6-9	¾	Steel/Tefcoat	3.95	100.3	1.55	39.4	-	0.25	-	25
½	4PS6-B	¾	Brass	3.95	100.3	1.55	39.4	-	0.26	-	25
½	4PS8	1	Steel	6.06	153.9	1.55	39.4	-	0.43	-	25
½	4PS8-B	1	Brass	6.06	153.9	1.55	39.4	-	0.44	-	25

## P-Series Dual Lock Replacement Seals

E



### P-Series Thor Interchange Replacement Seals

Body Size (inch)	Part No.	Coupler Style	Material	Seal Kit Contents	Pkg Qty	
					Bag	Box
½	4P-SKIT	All	Nitrile	Sealing Gasket	25	500
½	F-4P-SKIT	All	FKM	Sealing Gasket	25	500

### Locking Key

Part No.

4P-CLIP

Fits couplings with locking sleeve.

## Dual Lock Coupling with Ferrule

### Application:

- Used on large pneumatic hand-tools such as hammers, chippers, cable winders, air impact wrenches. Also widely used in refineries to convey air, water, and nitrogen, for military applications such as breathing air and fresh air systems, and on oil rigs for compression jacks and hand tools.

### Materials:

- Zinc coated coupling with plated steel ferrule. Also available in stainless steel

### Pressure:

- 300 PSI WP



Hose Size (inch)	Hose OD (mm)		Part No.
	From:	To:	
½	21	26	4PS4-WF43
¾	29	34	4PS6-WF63

FOR TECHNICAL GUIDELINES PLEASE REFER TO PAGE 176

## NK-Series Nitto Interchange

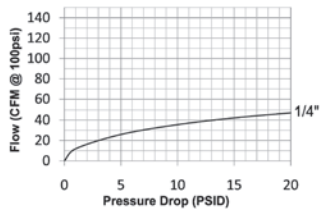

<b>Application:</b>	<ul style="list-style-type: none"> <li>From factory air line to pneumatic tool connection, available in various sizes and end connections. Excellent durability in any environment.</li> <li>An excellent general-purpose coupling for connecting factory air supply to pneumatic tool hose.</li> </ul>
<b>Materials:</b>	<ul style="list-style-type: none"> <li>Machined components are manufactured using solid steel bar stock</li> <li>Stainless steel balls, retaining rings, and springs maximise corrosion resistance and extend service life</li> <li>Steel componentry is plated using chrome-over-nickel plating</li> <li>Available in stainless steel</li> </ul>
<b>Seal Components:</b>	<ul style="list-style-type: none"> <li>Nitrile (Buna-N) seals are standard; temperature range <b>-40°C to 121°C (-40°F to 249°F)</b></li> </ul>
<b>Interchange Data:</b>	<ul style="list-style-type: none"> <li>Japanese industrial interchange pneumatic coupling</li> <li>Nitto Kohki Hi-Cupla 200, Rectus Series 13, and CEJN Series 315</li> </ul>

Body Size (inch)	Coupler / Plug			
	Max Working		Coupled Burst	
	PSI	bar	PSI	bar
¼	300	20	13,500	931
¾	300	20	13,500	931
½	300	20	13,500	931

## NK-Series Nitto Interchange Coupler

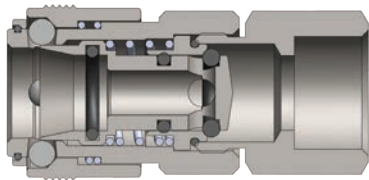

Female Thread

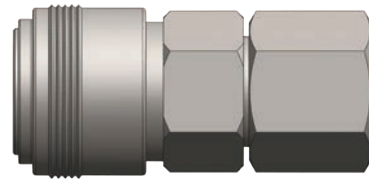

Body Size (inch)	Part No.	Threads (inch)	Material	Length (mm)	Max OD (mm)	Hex Size (inch)	Weight (kg)	Bag Qty
¼	20SF	¼ - 19 BSPP	Steel	50.0	25.0	19	0.08	10
¾	30SF	¾ - 14 BSPP	Steel	50.0	25.0	19	0.08	10
½	40SF	½ - 14 BSPP	Steel	50.0	25.0	21	0.09	5

## NK-Series Nitto Interchange Nipple

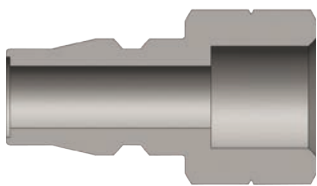

Female Thread

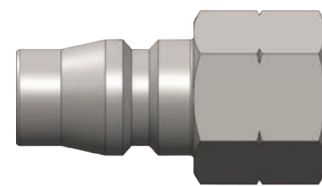

Body Size (inch)	Part No.	Threads (inch)	Material	Length (mm)	Max OD (mm)	Hex Size (inch)	Weight (kg)	Bag Qty
¼	20PF	¼ - 19 BSPP	Steel	38.0	17.0	5/8	0.03	10
¾	30PF	¾ - 14 BSPP	Steel	38.0	21.0	5/8	0.04	10
½	40PF	½ - 14 BSPP	Steel	39.0	26.0	5/8	0.06	5

# Hydraulic & Pneumatic

## NK-Series Nitto Interchange Coupler

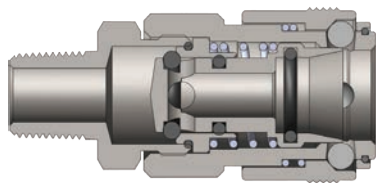

Male Thread

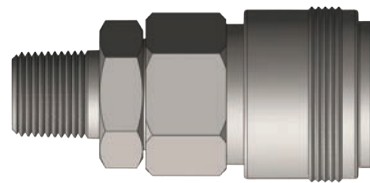

Body Size (inch)	Part No.	Threads (inch)	Material	Length (mm)	Max OD (mm)	Hex Size (inch)	Weight (kg)	Bag Qty
¼	20SM	¼ - 19 BSPT	Steel	50.0	25.0	19	0.08	10
⅜	30SM	⅜ - 14 BSPT	Steel	50.0	25.0	19	0.09	10
½	40SM	½ - 14 BSPT	Steel	52.0	25.0	21	0.09	5

## NK-Series Nitto Interchange Nipple

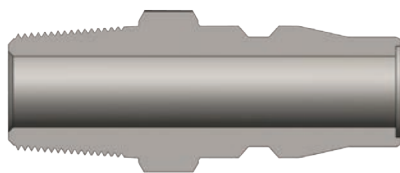

Male Thread

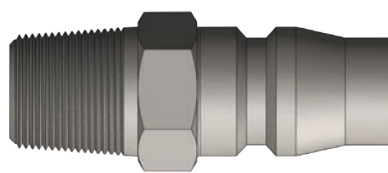

Body Size (inch)	Part No.	Threads (inch)	Material	Length (mm)	Hex Size (inch)	Weight (kg)	Bag Qty
¼	20PM	¼ - 19 BSPT	Steel	41.0	14	0.03	10
⅜	30PM	⅜ - 14 BSPT	Steel	42.0	14	0.04	10
½	40PM	½ - 14 BSPT	Steel	43.0	19	0.05	5

## NK-Series Nitto Interchange Coupler

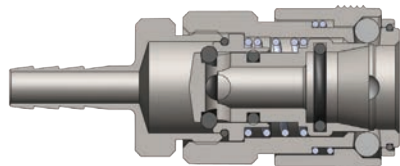

Hose Barb

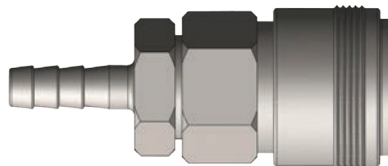

Body Size (inch)	Part No.	Threads (inch)	Material	Length (mm)	Max OD (mm)	Hex Size (inch)	Weight (kg)	Bag Qty
¼	20SH	¼	Steel	67.0	25.0	19	0.08	10
⅜	30SH	⅜	Steel	71.0	25.0	19	0.08	10
½	40SH	½	Steel	71.0	25.0	19	0.09	5

## NK-Series Nitto Interchange Nipple

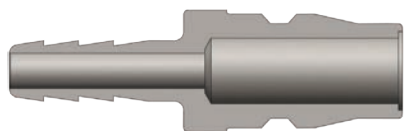

Hose Barb



Body Size (inch)	Part No.	Threads (inch)	Material	Length (mm)	Max OD (mm)	Hex Size (inch)	Weight (kg)	Bag Qty
¼	20PH	¼	Steel	57.0	16.0	-	0.03	10
⅜	30PH	⅜	Steel	61.0	18.0	-	0.03	10
½	40PH	½	Steel	65.0	18.0	-	0.03	5

FOR TECHNICAL GUIDELINES PLEASE REFER TO PAGE 179

## DF-Series Industrial Interchange

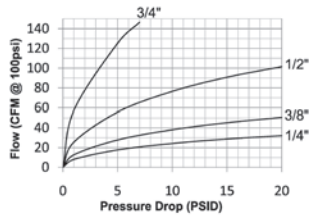

<b>Materials:</b>	<ul style="list-style-type: none"> <li>Machined components are manufactured using solid steel, brass, or 303 stainless steel bar stock</li> <li>Stainless steel balls, retaining rings, and springs maximise corrosion resistance and extend service life</li> <li>Steel componentry is plated using ROHS-compliant trivalent chrome</li> <li>Automatic couplers constructed of brass with steel tubular valve as standard (3/8\" to 3/4\" couplers have steel prong valves)</li> <li>1/4\" manual couplers constructed of brass with steel sleeve and steel tubular valve as standard</li> <li>3/8\" and 1/2\" manual couplers constructed of steel as standard with steel tubular valve</li> </ul>
<b>Seal Components:</b>	<ul style="list-style-type: none"> <li>Nitrile (Buna-N) seals are standard, providing a temperature range of <b>-40°C to 121°C (-40°F to 249°F)</b></li> </ul>
<b>Interchange Data:</b>	<ul style="list-style-type: none"> <li>Parker 20-Series manual interchange (F-Series)</li> <li>Parker 30-Series automatic interchange (D-Series)</li> <li>Foster 3, 4, 5, and 6 Series</li> <li>Hansen 1000, 400, 500 (F-Series)</li> <li>Hansen 3000, 4000, 5000, 6000 (D-Series)</li> <li>Ryco 300</li> <li>MIL-C-4109, A-A 59439 &amp; 15061508</li> </ul>

D-Series Automatic Industrial Interchange																
Body Size (inch)	Brass Coupler / Steel Plug				Brass Coupler / Plug				Steel Coupler / Plug				303 Stainless Steel Coupler / Plug			
	Max Working		Coupled Burst		Max Working		Coupled Burst		Max Working		Coupled Burst		Max Working		Coupled Burst	
	PSI	bar	PSI	bar	PSI	bar	PSI	bar	PSI	bar	PSI	bar	PSI	bar	PSI	bar
1/4	500	35	16,000	1,100	300	20	16,000	1,100	-	-	-	-	500	35	26,000	1,795
3/8	500	35	15,500	1,070	300	20	14,500	1,000	-	-	-	-	500	35	25,500	1,760
1/2	500	35	14,000	965	300	20	10,500	725	-	-	-	-	500	35	20,500	1,415
3/4	500	35	10,000	670	-	-	-	-	-	-	-	-	-	-	-	-

F-Series Manual Industrial Interchange																
Body Size (inch)	Brass Coupler / Steel Plug				Brass Coupler / Plug				Steel Coupler / Plug				303 Stainless Steel Coupler / Plug			
	Max Working		Coupled Burst		Max Working		Coupled Burst		Max Working		Coupled Burst		Max Working		Coupled Burst	
	PSI	bar	PSI	bar	PSI	bar	PSI	bar	PSI	bar	PSI	bar	PSI	bar	PSI	bar
1/4	500	35	9,000	620	300	20	8,500	586	500	35	6,500	448	500	35	11,500	795
3/8	500	35	11,500	790	300	20	10,000	690	500	35	19,500	1,345	500	35	20,500	1,415
1/2	-	-	-	-	-	-	-	-	500	35	15,500	1,070	500	35	15,000	1,035

Interchange Standards					Functional Parameters				
Size (inch)	US Military	US Government	International Standards	ANSI/NFPA Standards	Locking Ball Quantity	Air Inclusion	Fluid Loss	Vacuum Rating	Flow ΔP = 15 PSI
1/4	MIL-C-4109F	A-A-59439	ISO6150B	T3.20.14-1990	6	N/A	N/A	N/R	27 CFM
3/8	-	-	ISO6150B	T3.20.14-1990	6	N/A	N/A	N/R	45 CFM
1/2	MIL-C-4109F	A-A-59439	ISO6150B	T3.20.14-1990	6	N/A	N/A	N/R	91 CFM
3/4	-	-	ISO6150B	T3.20.14-1990	9	N/A	N/A	N/R	200 CFM

## DF-Series Profiles

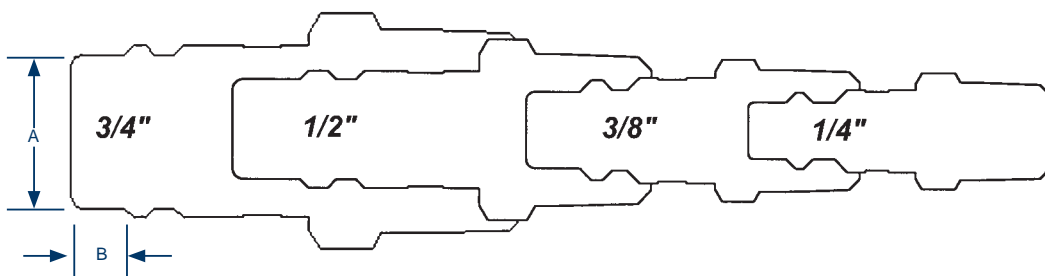

Body Size (inch)	A (mm)	B (mm)
1/4	7.94	4.76
3/8	11.11	7.94
1/2	14.29	9.53
3/4	20.64	7.94

# Hydraulic & Pneumatic

## D-Series Automatic Industrial Interchange Safety Coupler

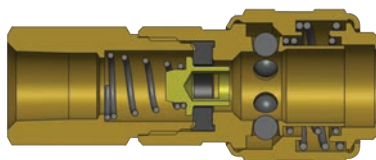

Female Thread



Body (inch)	Part No.	Thread (inch)	Body Material	Weight (kg)	Pkg Qty	
					Bag	Box
¼	2DF1-B	¼ - 27 NPTF	Brass	0.13	10	100
¼	2DF2-B	¼ - 18 NPTF	Brass	0.13	10	100
¼	2DF2-S	¼ - 18 NPTF	303 SS	0.13	10	100
¼	2DBF2-B	¼ - 19 BSPP	Brass	0.13	10	100
¼	2DF3-B	¾ - 18 NPTF	Brass	0.14	10	100
¼	2DF3-S	¾ - 18 NPTF	303 SS	0.14	10	100
¼	2DBF3-B	¾ - 19 BSPP	Brass	0.14	10	100
¾	3DF2-B	¼ - 18 NPTF	Brass	0.19	10	50
¾	3DF3-B	¾ - 18 NPTF	Brass	0.19	10	50
¾	3DF3-S	¾ - 18 NPTF	303 SS	0.19	10	50
¾	3DBF3-B	¾ - 19 BSPP	Brass	0.19	10	50
¾	3DF4-B	½ - 14 NPTF	Brass	0.21	10	50
½	4DF3-B	¾ - 18 NPTF	Brass	0.25	5	30
½	4DF4-B	½ - 14 NPTF	Brass	0.30	5	30
½	4DF4-S	½ - 14 NPTF	303 SS	0.30	5	30
½	4DBF4-B	½ - 14 BSPP	Brass	0.30	5	30
½	4DF6-B	¾ - 14 NPTF	Brass	0.35	5	30
¾	6DF4-B	½ - 14 NPTF	Brass	0.50	-	20
¾	6DF6-B	¾ - 14 NPTF	Brass	0.50	-	20
¾	6DF8-B	1 - 11½ NPTF	Brass	0.56	-	20

## F-Series Manual Industrial Interchange Coupler

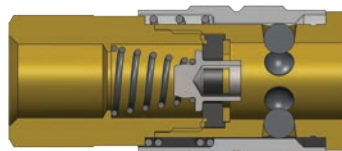

Female Thread

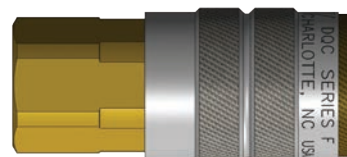

Body (inch)	Part No.	Thread (inch)	Body Material	Weight (kg)	Pkg Qty	
					Bag	Box
¼	2FF1-B	¼ - 27 NPTF	Brass	0.09	10	100
¼	2FBF1-B	¼ - 28 BSPP	Brass	0.09	10	100
¼	2FF2	¼ - 18 NPTF	Steel	0.09	10	100
¼	2FF2-B	¼ - 18 NPTF	Brass	0.09	10	100
¼	2FF2-S	¼ - 18 NPTF	303 SS	0.09	10	100
¼	2FBF2-B	¼ - 19 BSPP	Brass	0.09	10	100
¼	2FF3-B	¾ - 18 NPTF	Brass	0.09	10	100
¼	2FF3-S	¾ - 18 NPTF	303 SS	0.08	10	100
¼	2FBF3-B	¾ - 19 BSPP	Brass	0.09	10	100
¾	3FF2	¼ - 18 NPTF	Steel	0.14	10	50
¾	3FF3	¾ - 18 NPTF	Steel	0.14	10	50
¾	3FF3-S	¾ - 18 NPTF	303 SS	0.14	10	50
¾	3FBF3	¾ - 19 BSPP	Steel	0.14	10	50
¾	3FF4	½ - 14 NPTF	Steel	0.15	10	50
½	4FF3	¾ - 18 NPTF	Steel	0.21	5	30
½	4FF4	½ - 14 NPTF	Steel	0.25	5	30
½	4FF4-S	½ - 14 NPTF	303 SS	0.25	5	30
½	4FBF4	½ - 14 BSPP	Steel	0.25	5	30
½	4FF6	¾ - 14 NPTF	Steel	0.28	5	30

FOR TECHNICAL GUIDELINES PLEASE REFER TO PAGE 181



## DF-Series Industrial Interchange Nipple

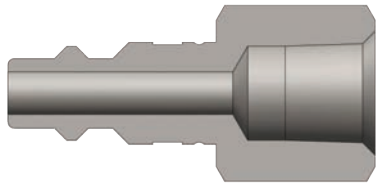

Female Thread



Body (inch)	Part No.	Thread (inch)	Body Material	Weight (kg)	Pkg Qty	
					Bag	Box
¼	D2F1	¼ - 27 NPTF	Steel	0.01	10	100
¼	D2F2	¼ - 18 NPTF	Steel	0.01	10	100
¼	D2F2-B	¼ - 18 NPTF	Brass	0.02	10	100
¼	D2F2-S	¼ - 18 NPTF	303 SS	0.02	10	100
¼	D2BF2	¼ - 19 BSPP	Steel	0.01	10	100
¼	D2F3	¾ - 18 NPTF	Steel	0.04	10	100
¼	D2F3-B	¾ - 18 NPTF	Brass	0.04	10	100
¼	D2F3-S	¾ - 18 NPTF	303 SS	0.04	10	100
¼	D2BF3	¾ - 19 BSPP	Steel	0.04	10	100
⅜	D3F2	¼ - 18 NPTF	Steel	0.03	10	50
⅜	D3F3	¾ - 18 NPTF	Steel	0.04	10	50
⅜	D3F3-B	¾ - 18 NPTF	Brass	0.04	10	50
⅜	D3F3-S	¾ - 18 NPTF	303 SS	0.04	10	50
⅜	D3BF3	¾ - 19 BSPP	Steel	0.04	10	50
⅜	D3F4	½ - 14 NPTF	Steel	0.06	10	50
½	D4F3	¾ - 18 NPTF	Steel	0.05	10	50
½	D4F4	½ - 14 NPTF	Steel	0.08	10	50
½	D4F4-B	½ - 14 NPTF	Brass	0.09	10	50
½	D4F4-S	½ - 14 NPTF	303 SS	0.08	10	50
½	D4BF4	½ - 14 BSPP	Steel	0.08	10	50
½	D4F6	¾ - 14 NPTF	Steel	0.12	10	50
½	D4F6-B	¾ - 14 NPTF	Brass	0.12	10	50
¾	D6F4	½ - 14 NPTF	Steel	0.10	5	20
¾	D6F8	1 - 11½ NPTF	Steel	0.21	5	20



## D-Series Automatic Industrial Interchange Coupler

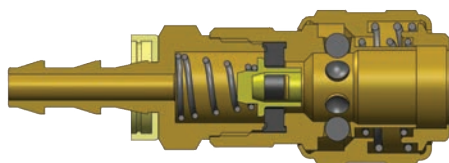

Push-Loc Barb



Body Size (inch)	Part No.	Hose ID (inch)	Body Material	Weight (kg)	Pkg Qty	
					Bag	Box
¼	2DB2-B	¼	Brass	0.12	10	100
¼	2DB3-B	⅜	Brass	0.13	10	100
⅜	3DB3-B	⅜	Brass	0.19	10	50
½	4DB4-B	½	Brass	0.25	5	30

FOR TECHNICAL GUIDELINES PLEASE REFER TO PAGE 181



# Hydraulic & Pneumatic

## D-Series Automatic Industrial Interchange Safety Coupler

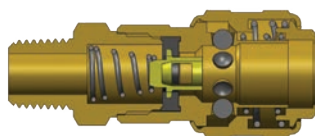

Male Thread



Body (inch)	Part No.	Thread (inch)	Body Material	Weight (kg)	Pkg Qty	
					Bag	Box
¼	2DM1-B	¼ - 27 NPTF	Brass	0.12	10	100
¼	2DM2-B	¼ - 18 NPTF	Brass	0.13	10	100
¼	2DM2-S	¼ - 18 NPTF	303 SS	0.13	10	100
¼	2DBM2-B	¼ - 19 BSPT	Brass	0.13	10	100
¼	2DM3-B	⅜ - 18 NPTF	Brass	0.13	10	100
¼	2DM3-S	⅜ - 18 NPTF	303 SS	0.13	10	100
¼	2DBM3-B	⅜ - 19 BSPT	Brass	0.13	10	100
⅜	3DM2-B	¼ - 18 NPTF	Brass	0.16	10	50
⅜	3DM3-B	⅜ - 18 NPTF	Brass	0.18	10	50
⅜	3DM3-S	⅜ - 18 NPTF	303 SS	0.18	10	50
⅜	3DBM3-B	⅜ - 19 BSPT	Brass	0.18	10	50
⅜	3DM4-B	½ - 14 NPTF	Brass	0.19	10	50
½	4DM3-B	⅜ - 18 NPTF	Brass	0.26	5	30
½	4DM4-B	½ - 14 NPTF	Brass	0.27	5	30
½	4DM4-S	½ - 14 NPTF	303 SS	0.28	5	30
½	4DBM4-B	½ - 14 BSPT	Brass	0.27	5	30
½	4DM6-B	¾ - 14 NPTF	Brass	0.30	5	30
¾	6DM4-B	½ - 14 NPTF	Brass	0.40	-	20
¾	6DM6-B	¾ - 14 NPTF	Brass	0.41	-	20
¾	6DM8-B	1 - 11½ NPTF	Brass	0.45	-	20

## F-Series Manual Industrial Interchange Coupler

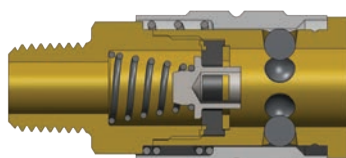

Male Thread

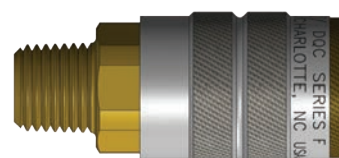

Body (inch)	Part No.	Thread (inch)	Body Material	Weight (kg)	Pkg Qty	
					Bag	Box
¼	2FM1-B	¼ - 27 NPTF	Brass	0.08	10	100
¼	2FM1-S	¼ - 27 NPTF	303 SS	0.08	10	100
¼	2FM2	¼ - 18 NPTF	Steel	0.08	10	100
¼	2FM2-B	¼ - 18 NPTF	Brass	0.09	10	100
¼	2FM2-S	¼ - 18 NPTF	303 SS	0.08	10	100
¼	2FBM2-B	¼ - 19 BSPT	Brass	0.09	10	100
¼	2FM3-B	⅜ - 18 NPTF	Brass	0.09	10	100
¼	2FM3-S	⅜ - 18 NPTF	303 SS	0.09	10	100
⅜	3FM2	¼ - 18 NPTF	Steel	0.12	10	50
⅜	3FM3	⅜ - 18 NPTF	Steel	0.12	10	50
⅜	3FM3-S	⅜ - 18 NPTF	303 SS	0.13	10	50
⅜	3FBM3	⅜ - 19 BSPT	Steel	0.12	10	50
⅜	3FM4	½ - 14 NPTF	Steel	0.13	10	50
½	4FM3	⅜ - 18 NPTF	Steel	0.19	5	30
½	4FM4	½ - 14 NPTF	Steel	0.20	5	30
½	4FM4-S	½ - 14 NPTF	303 SS	0.21	5	30
½	4FBM4	½ - 14 BSPT	Steel	0.20	5	30
½	4FM6	¾ - 14 NPTF	Steel	0.23	5	30

FOR TECHNICAL GUIDELINES PLEASE REFER TO PAGE 181

## DF-Series Industrial Interchange Nipple

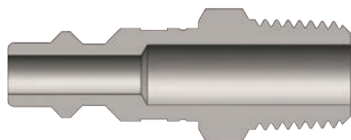

Male Thread



Body (inch)	Part No.	Thread (inch)	Body Material	Weight (kg)	Pkg Qty	
					Bag	Box
¼	D2M1	⅛ - 27 NPTF	Steel	0.02	10	100
¼	D2M1-B	⅛ - 27 NPTF	Brass	0.02	10	100
¼	D2M1-S	⅛ - 27 NPTF	303 SS	0.02	10	100
¼	D2M2	¼ - 18 NPTF	Steel	0.02	10	100
¼	D2M2-B	¼ - 18 NPTF	Brass	0.02	10	100
¼	D2M2-S	¼ - 18 NPTF	303 SS	0.02	10	100
¼	D2BM2	¼ - 19 BSPT	Steel	0.02	10	100
¼	D2M3	⅜ - 18 NPTF	Steel	0.02	10	100
¼	D2M3-B	⅜ - 18 NPTF	Brass	0.03	10	100
¼	D2M3-S	⅜ - 18 NPTF	303 SS	0.04	10	100
¼	D2BM3	⅜ - 19 BSPT	Steel	0.03	10	100
⅜	D3M2	¼ - 18 NPTF	Steel	0.04	10	50
⅜	D3M3	⅜ - 18 NPTF	Steel	0.04	10	50
⅜	D3M3-B	⅜ - 18 NPTF	Brass	0.04	10	50
⅜	D3M3-S	⅜ - 18 NPTF	303 SS	0.04	10	50
⅜	D3BM3	⅜ - 19 BSPT	Steel	0.04	10	50
½	D4M2	¼ - 18 NPTF	Steel	0.06	10	50
½	D4M3	⅜ - 18 NPTF	Steel	0.07	10	50
½	D4M4	½ - 14 NPTF	Steel	0.07	10	50
½	D4M4-B	½ - 14 NPTF	Brass	0.08	10	50
½	D4M4-S	½ - 14 NPTF	303 SS	0.07	10	50
½	D4BM4	½ - 14 BSPT	Steel	0.07	10	50
½	D4M6	¾ - 14 NPTF	Steel	0.11	10	50
½	D4M6-B	¾ - 14 NPTF	Brass	0.11	10	50
¾	D6M4	½ - 14 NPTF	Steel	0.10	5	20
¾	D6M6	¾ - 14 NPTF	Steel	0.11	5	20
¾	D6M8	1 - 11½ NPTF	Steel	0.12	5	20

## D-Series Automatic Industrial Interchange Safety Coupler

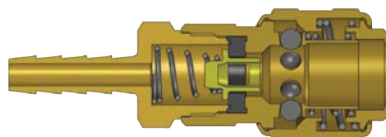

Standard Hose Barb



Body Size (inch)	Part No.	Hose ID (inch)	Body Material	Weight (kg)	Pkg Qty	
					Bag	Box
¼	2DS2-B	¼	Brass	0.12	10	100
¼	2DS2-S	¼	303 SS	0.12	10	100
¼	2DS3-B	⅜	Brass	0.12	10	100
¼	2DS3-S	⅜	303 SS	0.13	10	100
⅜	3DS2-B	¼	Brass	0.17	10	50
⅜	3DS3-B	⅜	Brass	0.18	10	50
⅜	3DS3-S	⅜	303 SS	0.18	10	50
⅜	3DS4-B	½	Brass	0.19	10	50
½	4DS3-B	⅜	Brass	0.25	5	30
½	4DS4-B	½	Brass	0.27	5	30
½	4DS4-S	½	303 SS	0.27	5	30
½	4DS6-B	¾	Brass	0.30	5	30
¾	6DS4-B	½	Brass	0.41	-	20
¾	6DS6-B	¾	Brass	0.42	-	20
¾	6DS8-B	1	Brass	0.47	-	20

FOR TECHNICAL GUIDELINES PLEASE REFER TO PAGE 181

# Hydraulic & Pneumatic

## F-Series Manual Industrial Interchange Coupler

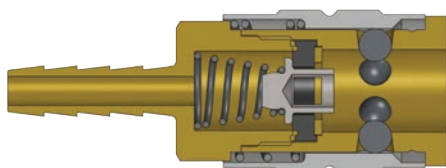

Standard Hose Barb

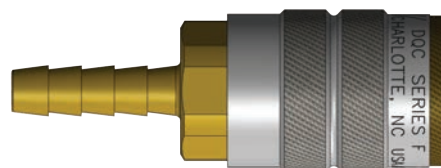

Body Size (inch)	Part No.	Hose ID (inch)	Body Material	Weight (kg)	Pkg Qty	
					Bag	Box
¼	2FS2	¼	Steel	0.08	10	100
¼	2FS2-B	¼	Brass	0.08	10	100
¼	2FS2-S	¼	303 SS	0.08	10	100
¼	2FS2.5-B	5/16	Brass	0.08	10	100
¼	2FS3-B	3/8	Brass	0.08	10	100
¼	2FS3-S	3/8	303 SS	0.09	10	100
3/8	3FS2	¼	Steel	0.12	10	50
3/8	3FS3	3/8	Steel	0.12	10	50
3/8	3FS3-S	3/8	303 SS	0.13	10	50
3/8	3FS4	½	Steel	0.13	10	50
½	4FS3	3/8	Steel	0.19	5	30
½	4FS4	½	Steel	0.20	5	30
½	4FS4-S	½	303 SS	0.20	5	30
½	4FS6	¾	Steel	0.22	5	30

E

## DF-Series Industrial Interchange Nipple

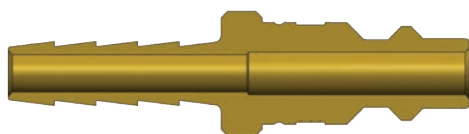

Standard Hose Barb

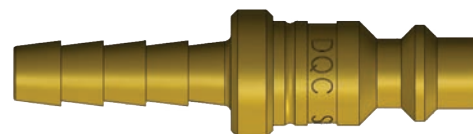

Body Size (inch)	Part No.	Hose ID (inch)	Body Material	Weight (kg)	Pkg Qty	
					Bag	Box
¼	D2S2	¼	Steel	0.02	10	100
¼	D2S2-S	¼	303 SS	0.02	10	100
¼	D2S2.5	5/16	Steel	0.02	10	100
¼	D2S3	3/8	Steel	0.02	10	100
¼	D2S3-B	3/8	Brass	0.02	10	100
¼	D2S3-S	3/8	303 SS	0.02	10	100
3/8	D3S2	¼	Steel	0.03	10	50
3/8	D3S3	3/8	Steel	0.03	10	50
3/8	D3S3-B	3/8	Brass	0.04	10	50
3/8	D3S3-S	3/8	303 SS	0.04	10	50
3/8	D3S4	½	Steel	0.04	10	50
½	D4S3	3/8	Steel	0.04	10	50
½	D4S3-B	3/8	Brass	0.05	10	50
½	D4S4-B	½	Brass	0.05	10	50
½	D4S4-S	½	303 SS	0.05	10	50
½	D4S6	¾	Steel	0.08	10	50
½	D4S6-B	¾	Brass	0.08	10	50
¾	D6S4	½	Steel	0.09	5	20
¾	D6S6	¾	Steel	0.10	5	20
¾	D6S8	1	Steel	0.16	5	20



It is important to be safe when installing quick disconnect couplings into a pneumatic circuit. Never install a pneumatic coupling directly into an air tool. Use a piece of hose that is at least 18" long-between the tool and the coupling to prevent damage to the coupling. To protect the operator, safety devices, such as a safety check valve and safety cable, should be installed in case there is a hose or coupling failure.

FOR TECHNICAL GUIDELINES PLEASE REFER TO PAGE 181

## H-Series ISO7241 Series 'B'

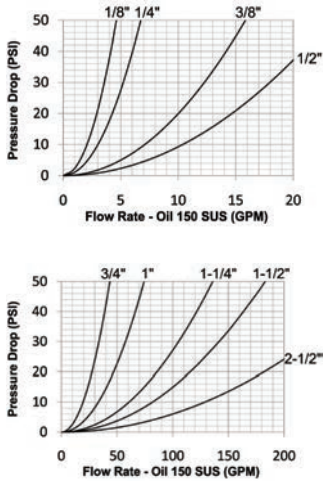

<b>Materials:</b>	<ul style="list-style-type: none"> <li>Machined components are manufactured using solid steel, brass, 303 stainless steel, or 316 stainless steel bar stock</li> <li>Stainless steel balls, retaining rings, and springs maximise corrosion resistance and extend service life</li> <li>Steel componentry is plated using ROHS-compliant trivalent chrome</li> <li>Steel coupler sleeves are hardened to resist deformation and maximise service life</li> <li>Steel nipples are hardened to provide heavy-duty performance and resist brinelling</li> </ul>
<b>Seal Components:</b>	<ul style="list-style-type: none"> <li>Nitrile (Buna-N) seals are standard, providing a temperature range of <b>-40°C to 121°C (-40°F to 249°F)</b></li> <li>1/8" to 1" steel and stainless couplers have a PTFE anti-extrusion ring</li> <li>1/8" to 2 1/2" brass couplers have a redundant O-ring sealing system (dual O-rings/no PTFE back-up ring)</li> <li>1 1/4" to 2 1/2" steel and stainless couplers have a redundant O-ring sealing system (dual O-rings/no PTFE back-up ring)</li> <li>Valve seals are crimped in place to maintain integrity during excessive flow conditions and pressurised connection</li> </ul>
<b>Interchange Data:</b>	<ul style="list-style-type: none"> <li>Interchangeable to ISO7241 Series B</li> <li>Parker 60-Series, Snap-Tite 72-Series, Hansen HK-Series, Faster Series HNV Aeroquip/Eaton FD45, Stucchi Series IRB/IRBO/IRBX</li> </ul>
<b>Standards:</b>	<ul style="list-style-type: none"> <li>H-Series couplers and nipples are fully compliant with the parameters outlined in ISO7241 Series B</li> </ul>

Size (inch)	Steel Coupler / Plug				Brass Coupler / Plug				303 Stainless Coupler / Plug				316 Stainless Coupler / Plug			
	Max Working		Coupled Burst		Max Working		Coupled Burst		Max Working		Coupled Burst		Max Working		Coupled Burst	
	PSI	Bar	PSI	Bar	PSI	Bar	PSI	Bar	PSI	Bar	PSI	Bar	PSI	Bar	PSI	Bar
1/8	4,000	275	14,500	1000	3,000	200	16,500	1100	3,500	240	29,500	2000	3,500	240	29,500	2000
1/4	5,000	345	22,500	1550	3,000	200	15,000	1000	3,500	240	31,500	2150	3,500	240	33,000	2200
3/8	4,000	275	16,500	1150	2,500	175	12,000	800	3,500	240	26,500	1800	3,500	240	28,000	1900
1/2	4,000	275	16,000	1100	2,500	175	11,500	750	3,500	240	27,500	1900	3,500	240	22,000	1500
3/4	4,000	275	16,500	1150	2,000	138	12,000	800	3,000	200	16,000	1100	3,000	200	21,500	1450
1	4,000	275	16,000	1100	1,500	100	8,500	600	2,000	138	15,000	1000	2,000	138	15,000	1000
1 1/4	2,500	170	10,000	700	1,000	70	6,500	450	2,000	138	10,000	700	1,000	70	8,500	580
1 1/2	2,500	170	12,500	850	1,000	70	6,500	450	1,500	100	8,500	580	1,000	70	7,000	480
2 1/2	1,500	100	6,000	400	700	50	5,500	380	1,000	70	6,500	450	900	62	6,000	400

Interchange Standards					Functional Parameters				
Size (inch)	US Military	US Government	International Standards	ANSI / NFPA Standards	Locking Ball Qty	Air Inclusion	Fluid Loss	Vacuum inch HG	Flow (Lpm) ΔP = 22 PSI
1/8	-	-	ISO7241-B	B93.113M-B	8	0.6cc	0.3cc	27.4	12
1/4	-	-	ISO7241-B	B93.113M-B	8	1.1cc	0.9cc	27.4	17
3/8	-	-	ISO7241-B	B93.113M-B	9	2.6cc	1.8cc	27.4	38
1/2	-	-	ISO7241-B	B93.113M-B	9	3.8cc	2.9cc	27.4	57
3/4	-	-	ISO7241-B	B93.113M-B	12	10.8cc	9.7cc	27.4	110
1	-	-	ISO7241-B	B93.113M-B	12	15.9cc	15.3cc	27.4	190
1 1/4	-	-	ISO7241-B	B93.113M-B	12	30.0cc	45.0cc	N/R	341
1 1/2	-	-	ISO7241-B	B93.113M-B	12	60.0cc	75.0cc	N/R	454
2 1/2	-	-	ISO7241-B	B93.113M-B	15	N/A	N/A	N/R	738

\* These particular sizes are not outlined within the documented standard category.

H-Series Standards						
Size (inch)	Parker	Snap - Tite	Faster	Hansen	Aeroquip / Eaton	Stucchi
1/8	60-Series	72-Series	Series 'HNV'	HK-Series	FD45	IRB / IRBO / IRBX Series
1/4	60-Series	72-Series	Series 'HNV'	HK-Series	FD45	IRB / IRBO / IRBX Series
3/8	60-Series	72-Series	Series 'HNV'	HK-Series	FD45	IRB / IRBO / IRBX Series
1/2	60-Series	72-Series	Series 'HNV'	HK-Series	FD45	IRB / IRBO / IRBX Series
3/4	60-Series	72-Series	Series 'HNV'	HK-Series	FD45	IRB / IRBO / IRBX Series
1	60-Series	72-Series	Series 'HNV'	HK-Series	FD45	IRB / IRBO / IRBX Series
1 1/4	-	-	-	HK-Series	FD45	IRB / IRBO / IRBX Series
1 1/2	60-Series	-	Series 'HNV'	HK-Series	FD45	IRB / IRBO / IRBX Series

ISO-B couplings are not recommended for blowout prevention (BOP) systems.

# Hydraulic & Pneumatic

## H-Series Profiles

Body Size (inch)	A (mm)	B (mm)
1/8	11.11	7.94
1/4	14.29	9.53
3/8	19.05	12.70
1/2	23.81	12.70
3/4	31.75	19.05
1	38.10	20.64
1 1/4	36.51	26.40
1 1/2	42.86	33.34
2 1/2	58.74	36.51

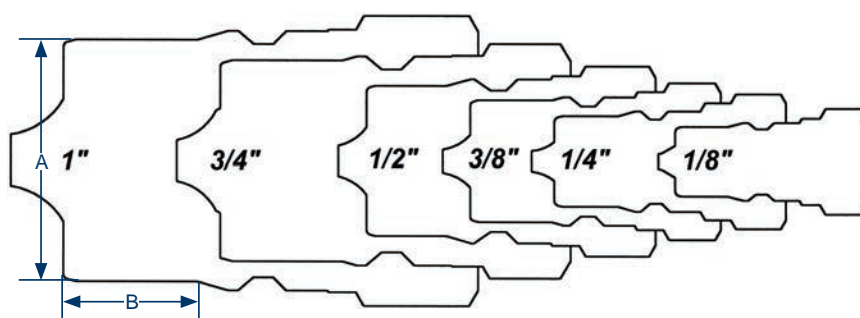

## H-Series Interchange - Hermaphrodite Dust Plugs & Caps



Size (inch)	Part No.	Body Material	Pkg Qty	
			Bag	Box
1/4	2HDP-H2DC	Nitrile	10	50
3/8	3HDP-H3DC	Nitrile	10	50
1/2	4HDP-H4DC	Nitrile	10	50
3/4	6HDP-H6DC	Nitrile	5	25
1	8HDP-H8DC	Nitrile	5	25
1 1/4	8HDP-H8DC	Nitrile	5	25

Note: 8HDP-H8DC fits both 1" and 1 1/4" body sizes.

## H-Series Interchange - Coupler Rigid Dust Plugs



Size (inch)	Part No.	Lanyard	Body Material	Weight (kg)	Pkg Qty	
					Bag	Box
1/4	2HDP-A	SS Bead Chain	Aluminium	0.01	10	50
3/8	3HDP-A	SS Bead Chain	Aluminium	0.01	10	50
1/2	4HDP-A	SS Bead Chain	Aluminium	0.01	10	50
3/4	6HDP-A	SS Bead Chain	Aluminium	0.04	5	25
1	8HDP-A	SS Bead Chain	Aluminium	0.06	5	25
1 1/2	12HDP-A	SS Bead Chain	Aluminium	0.13	5	25
2 1/2	20HDP-A	SS Chain	Aluminium	0.19	-	10

## H-Series Interchange - Nipple Rigid Dust Caps



Size (inch)	Part No.	Lanyard	Body Material	Weight (kg)	Pkg Qty	
					Bag	Box
1/4	H2DC-A	SS Bead Chain	Aluminium	0.01	10	50
3/8	H3DC-A	SS Bead Chain	Aluminium	0.03	10	50
1/2	H4DC-A	SS Bead Chain	Aluminium	0.06	10	50
3/4	H6DC-A	SS Bead Chain	Aluminium	0.09	5	25
1	H8DC-A	SS Bead Chain	Aluminium	0.12	5	25
1 1/2	H12DC-A	SS Bead Chain	Aluminium	0.11	5	25
2 1/2	H20DC-A	SS Chain	Aluminium	0.18	-	10

- NPTF and ORB thread styles also available
- A complete range of seal options are available

FOR TECHNICAL GUIDELINES PLEASE REFER TO PAGE 187

## H-Series Interchange - Couplers

Size (inch)	Part No.	Thread Size (inch)	Body Material	Weight (kg)	Pkg Qty	
					Bag	Box
¼	2HF2	¼ - 18 NPTF	Steel	0.13	10	50
¼	2HF2-B	¼ - 18 NPTF	Brass	0.14	10	50
¼	2HF2-S	¼ - 18 NPTF	303 SS	0.13	10	50
¼	2HF2-SS	¼ - 18 NPTF	316 SS	0.13	10	50
¼	2HBF2	¼ - 19 BSPP	Steel	0.13	10	50
¼	2HBF2-B	¼ - 19 BSPP	Brass	0.15	10	50
¼	2HBF2-S	¼ - 19 BSPP	303 SS	0.13	10	50
¼	2HBF2-SS	¼ - 19 BSPP	316 SS	0.13	10	50
¼	2HOF3	¼ - 18 ORB	Steel	0.14	10	50
⅜	3HF3	⅜ - 18 NPTF	Steel	0.18	10	50
⅜	3HF3-B	⅜ - 18 NPTF	Brass	0.20	10	50
⅜	3HF3-S	⅜ - 18 NPTF	303 SS	0.18	10	50
⅜	3HF3-SS	⅜ - 18 NPTF	316 SS	0.18	10	50
⅜	3HBF3	⅜ - 19 BSPP	Steel	0.18	10	50
⅜	3HBF3-B	⅜ - 19 BSPP	Brass	0.20	10	50
⅜	3HBF3-S	⅜ - 19 BSPP	303 SS	0.18	10	50
⅜	3HBF3-SS	⅜ - 19 BSPP	316 SS	0.18	10	50
⅜	3HOF4	¾ - 16 ORB	Steel	0.23	10	50
½	4HF4	½ - 14 NPTF	Steel	0.33	5	25
½	4HF4-B	½ - 14 NPTF	Brass	0.36	5	25
½	4HF4-S	½ - 14 NPTF	303 SS	0.34	5	25
½	4HF4-SS	½ - 14 NPTF	316 SS	0.34	5	25
½	4HBF4	½ - 14 BSPP	Steel	0.33	5	25
½	4HBF4-B	½ - 14 BSPP	Brass	0.36	5	25
½	4HBF4-S	½ - 14 BSPP	303 SS	0.34	5	25
½	4HBF4-SS	½ - 14 BSPP	316 SS	0.34	5	25
½	4HOF5	⅞ - 14 ORB	Steel	0.35	5	25
¾	6HF6	¾ - 14 NPTF	Steel	0.59	-	10
¾	6HF6-B	¾ - 14 NPTF	Brass	0.62	-	10
¾	6HF6-S	¾ - 14 NPTF	303 SS	0.59	-	10
¾	6HF6-SS	¾ - 14 NPTF	316 SS	0.60	-	10
¾	6HBF6	¾ - 14 BSPP	Steel	0.59	-	10
¾	6HBF6-B	¾ - 14 BSPP	Brass	0.62	-	10
¾	6HBF6-S	¾ - 14 BSPP	303 SS	0.59	-	10
¾	6HBF6-SS	¾ - 14 BSPP	316 SS	0.60	-	10
¾	6HOF6	1½ - 12 ORB	Steel	0.63	-	10
1	8HF8	1 - 11½ NPTF	Steel	0.88	-	10
1	8HF8-B	1 - 11½ NPTF	Brass	0.90	-	10
1	8HF8-S	1 - 11½ NPTF	303 SS	0.88	-	10
1	8HF8-SS	1 - 11½ NPTF	316 SS	0.88	-	10
1	8HBF8	1 - 11 BSPP	Steel	0.88	-	10
1	8HBF8-B	1 - 11 BSPP	Brass	0.90	-	10
1	8HBF8-S	1 - 11 BSPP	303 SS	0.88	-	10
1	8HBF8-SS	1 - 11 BSPP	316 SS	0.88	-	10



Female Thread

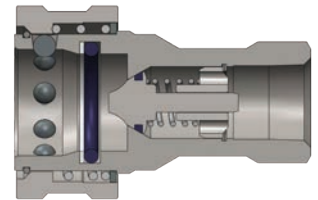

FOR TECHNICAL GUIDELINES PLEASE REFER TO PAGE 187



# Hydraulic & Pneumatic

## H-Series Interchange - High-Volume Couplers



Female Thread

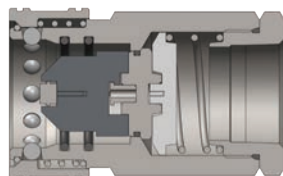

NPTF and ORB thread styles, and a complete range of seal options are available.

Size (inch)	Part No.	Thread Size (inch)	Body Material	Weight (kg)	Pkg Qty	
					Bag	Box
1¼	10HF10	1¼ - 11½ NPTF	Steel	1.59	-	1
1¼	10HF10-B	1¼ - 11½ NPTF	Brass	1.59	-	1
1¼	10HF10-S	1¼ - 11½ NPTF	303 SS	1.59	-	1
1¼	10HBF10	1¼ - 11 BSPP	Steel	1.59	-	1
1½	12HF10	1¼ - 11½ NPTF	Steel	2.13	-	1
1½	12HF10-B	1¼ - 11½ NPTF	Brass	2.12	-	1
1½	12HF10-S	1¼ - 11½ NPTF	303 SS	2.12	-	1
1½	12HOF10	1½ - 12 ORB	Steel	2.14	-	1
1½	12HF12	1½ - 11½ NPTF	Steel	2.13	-	1
1½	12HF12-B	1½ - 11½ NPTF	Brass	2.08	-	1
1½	12HF12-S	1½ - 11½ NPTF	303 SS	2.12	-	1
1½	12HF12-SS	1½ - 11½ NPTF	316 SS	2.12	-	1
1½	12HBF12	1½ - 11 BSPP	Steel	2.13	-	1
1½	12HBF12-B	1½ - 11 BSPP	Brass	2.08	-	1
1½	12HBF12-S	1½ - 11 BSPP	303 SS	2.12	-	1
1½	12HBF12-SS	1½ - 11 BSPP	316 SS	2.12	-	1
1½	12HOF12	1½ - 12 ORB	Steel	2.14	-	1
2½	20HF16	2 - 11½ NPTF	Steel	5.00	-	1
2½	20HF16-B	2 - 11½ NPTF	Brass	5.03	-	1
2½	20HF20	2½ - 8 NPTF	Steel	5.05	-	1
2½	20HF24	3 - 8 NPTF	Steel	5.22	-	1

E

## H-Series Interchange - High-Volume Nipples

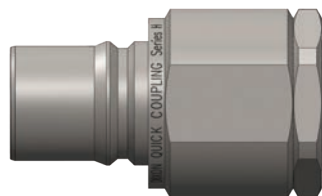

Female Thread

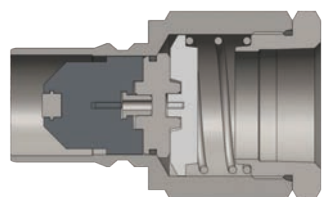

Size (inch)	Part No.	Thread Size (inch)	Body Material	Weight (kg)	Pkg Qty	
					Bag	Box
1¼	H10F10	1¼ - 11½ NPTF	Steel	0.99	-	1
1¼	H10F10-B	1¼ - 11½ NPTF	Brass	0.99	-	1
1¼	H10F10-S	1¼ - 11½ NPTF	303 SS	0.99	-	1
1¼	H10BF10	1¼ - 11 BSPP	Steel	0.99	-	1
1½	H12F10	1¼ - 11½ NPTF	Steel	1.40	-	1
1½	H12F10-B	1¼ - 11½ NPTF	Brass	1.40	-	1
1½	H12F10-S	1¼ - 11½ NPTF	303 SS	1.40	-	1
1½	H12OF10	1½ - 12 ORB	Steel	1.43	-	1
1½	H12F12	1½ - 11½ NPTF	Steel	1.40	-	1
1½	H12F12-B	1½ - 11½ NPTF	Brass	1.34	-	1
1½	H12F12-S	1½ - 11½ NPTF	303 SS	1.39	-	1
1½	H12F12-SS	1½ - 11½ NPTF	316 SS	1.38	-	1
1½	H12BF12	1½ - 11 BSPP	Steel	1.41	-	1
1½	H12BF12-B	1½ - 11 BSPP	Brass	1.34	-	1
1½	H12BF12-S	1½ - 11 BSPP	303 SS	1.39	-	1
1½	H12BF12-SS	1½ - 11 BSPP	316 SS	1.39	-	1
1½	H12OF12	1½ - 12 ORB	Steel	1.43	-	1
2½	H20F16	2 - 11½ NPTF	Steel	3.33	-	1
2½	H20F16-B	2 - 11½ NPTF	Brass	3.33	-	1
2½	H20F20	2½ - 8 NPTF	Steel	3.27	-	1
2½	H20F24	3 - 8 NPTF	Steel	3.43	-	1

- NPTF and ORB thread styles also available
- A complete range of seal options are available

FOR TECHNICAL GUIDELINES PLEASE REFER TO PAGE 187



## H-Series Interchange - Nipples

Size (inch)	Part No.	Thread Size (inch)	Body Material	Weight (kg)	Pkg Qty	
					Bag	Box
¼	H2F2	¼ - 18 NPTF	Steel	0.03	10	50
¼	H2F2-B	¼ - 18 NPTF	Brass	0.04	10	50
¼	H2F2-S	¼ - 18 NPTF	303 SS	0.03	10	50
¼	H2F2-SS	¼ - 18 NPTF	316 SS	0.03	10	50
¼	H2BF2	¼ - 19 BSPP	Steel	0.03	10	50
¼	H2BF2-B	¼ - 19 BSPP	Brass	0.04	10	50
¼	H2BF2-S	¼ - 19 BSPP	303 SS	0.03	10	50
¼	H2BF2-SS	¼ - 19 BSPP	316 SS	0.03	10	50
¼	H2OF3	¾ - 18 ORB	Steel	0.04	10	50
⅜	H3F3	⅜ - 18 NPTF	Steel	0.05	10	50
⅜	H3F3-B	⅜ - 18 NPTF	Brass	0.04	10	50
⅜	H3F3-S	⅜ - 18 NPTF	303 SS	0.05	10	50
⅜	H3F3-SS	⅜ - 18 NPTF	316 SS	0.05	10	50
⅜	H3BF3	⅜ - 19 BSPP	Steel	0.05	10	50
⅜	H3BF3-B	⅜ - 19 BSPP	Brass	0.04	10	50
⅜	H3BF3-S	⅜ - 19 BSPP	303 SS	0.05	10	50
⅜	H3BF3-SS	⅜ - 19 BSPP	316 SS	0.05	10	50
⅜	H3OF4	¾ - 16 ORB	Steel	0.07	10	50
½	H4F4	½ - 14 NPTF	Steel	0.10	5	25
½	H4F4-B	½ - 14 NPTF	Brass	0.11	5	25
½	H4F4-S	½ - 14 NPTF	303 SS	0.10	5	25
½	H4F4-SS	½ - 14 NPTF	316 SS	0.10	5	25
½	H4BF4	½ - 14 BSPP	Steel	0.11	5	25
½	H4BF4-B	½ - 14 BSPP	Brass	0.11	5	25
½	H4BF4-S	½ - 14 BSPP	303 SS	0.11	5	25
½	H4BF4-SS	½ - 14 BSPP	316 SS	0.11	5	25
½	H4OF5	¾ - 14 ORB	Steel	0.12	5	25
¾	H6F6	¾ - 14 NPTF	Steel	0.21	-	10
¾	H6F6-B	¾ - 14 NPTF	Brass	0.22	-	10
¾	H6F6-S	¾ - 14 NPTF	303 SS	0.21	-	10
¾	H6F6-SS	¾ - 14 NPTF	316 SS	0.21	-	10
¾	H6BF6	¾ - 14 BSPP	Steel	0.21	-	10
¾	H6BF6-B	¾ - 14 BSPP	Brass	0.23	-	10
¾	H6BF6-S	¾ - 14 BSPP	303 SS	0.21	-	10
¾	H6BF6-SS	¾ - 14 BSPP	316 SS	0.21	-	10
¾	H6OF6	1½ - 12 ORB	Steel	0.21	-	10
1	H8F8	1 - 11½ NPTF	Steel	0.34	-	10
1	H8F8-B	1 - 11½ NPTF	Brass	0.34	-	10
1	H8F8-S	1 - 11½ NPTF	303 SS	0.34	-	10
1	H8F8-SS	1 - 11½ NPTF	316 SS	0.34	-	10
1	H8BF8	1 - 11 BSPP	Steel	0.34	-	10
1	H8BF8-B	1 - 11 BSPP	Brass	0.34	-	10
1	H8BF8-S	1 - 11 BSPP	303 SS	0.34	-	10
1	H8BF8-SS	1 - 11 BSPP	316 SS	0.34	-	10
1	H8OF8	1½ - 12 ORB	Steel	0.36	-	10



Female Thread

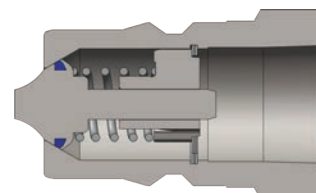

FOR TECHNICAL GUIDELINES PLEASE REFER TO PAGE 187



## H-BOP Series Hydraulic Couplings

<b>Materials:</b>	<ul style="list-style-type: none"> <li>Machined components are manufactured using solid steel or 316 stainless steel bar stock</li> <li>Stainless steel balls, retaining rings, and springs maximise corrosion resistance and extend service life</li> <li>Steel componentry is plated using ROHS-compliant trivalent chrome</li> <li>Steel coupler sleeves are hardened to resist deformation and maximise service life</li> <li>Steel nipples are hardened to provide heavy-duty performance and resist brinelling</li> <li>Red powder-coated coupler sleeve and nipple hex for easy BOP service identification</li> <li>Locking sleeve is standard</li> </ul>
<b>Seal Components:</b>	<ul style="list-style-type: none"> <li>Blowout prevention (BOP) couplings contain severe service FKM seals</li> <li>PTFE anti-extrusion ring protects main coupling body seal from dynamic impulse pressure damage</li> <li>Coupler has redundant O-ring sealing system</li> <li>Valve seals are crimped in place to maintain integrity during excessive flow conditions and pressurised connection</li> </ul>
<b>Interchange Data:</b>	<ul style="list-style-type: none"> <li>Eaton/Hansen HKFR-Series, DNP HNV-BOP Series</li> <li>Interchangeable to ISO7241 Series B</li> </ul>

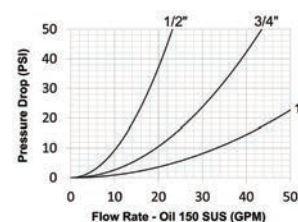

- BOP couplings have been fire tested and Lloyd's certified to **700°C (1292°F)** in accordance with API 16D, certificate available upon request
- Use H-Series dust caps and dust plugs found on page 188

### Rated Pressure Chart:

H-BOP-Series Blowout Prevention Safety Interchange										
Size (inch)	Brass Coupler / Plug				Brass Coupler / Steel Plug				Lloyd's Test Pressure	Flow ΔP = 22 PSI
	Max Working		Burst		Max Working		Burst			
	PSI	Bar	PSI	Bar	PSI	Bar	PSI	Bar		
½	5,000	345	16,000	1100	5,000	345	22,000	1500	5000	15 GPM
¾	5,000	345	16,500	1150	5,000	345	21,500	1450	5000	29 GPM
1	5,000	345	16,000	1100	5,000	345	15,000	1000	5000	50 GPM

## H-BOP Series Hydraulic Couplers

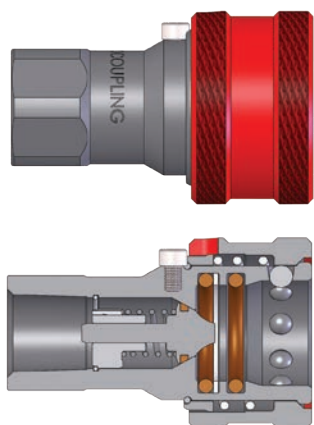

H-BOP Series Blowout Prevention Safety Coupler (Female Threads)											
Size (inch)	Part Detail			Length		Maximum OD		Hex (inch)	Weight (kg)	Package Qty	
	Part No.	Threads	Material	inch	mm	inch	mm			Bag	Box
½	4HF4-BOP	½" - 14 NPTF	Steel	2.86	72.6	1.86	47.2	1-5/16	0.33	-	25
½	4HF4-SS-BOP	½" - 14 NPTF	316 SS	2.86	72.6	1.86	47.2	1-5/16	0.35	-	25
¾	6HF6-BOP	¾" - 14 NPTF	Steel	3.55	90.2	2.22	56.4	1-5/16	0.59	-	10
¾	6HF6-SS-BOP	¾" - 14 NPTF	316 SS	3.55	90.2	2.22	56.4	1-5/16	0.60	-	10
1	8HF8-BOP	1" - 11 ½ NPTF	Steel	4.13	104.9	2.49	63.2	1%	0.88	-	10
1	8HF8-SS-BOP	1" - 11 ½ NPTF	316 SS	4.13	104.9	2.49	63.2	1%	0.88	-	10

## H-BOP Series Hydraulic Nipples

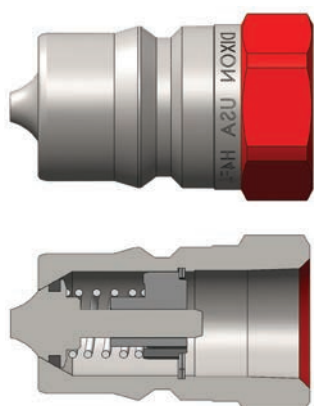

H-BOP Series Blowout Prevention Safety Nipple (Female Threads)											
Size (inch)	Part Detail			Length		Maximum OD		Hex (inch)	Weight (kg)	Package Qty	
	Part No.	Threads	Material	inch	mm	inch	mm			Bag	Box
½	H4F4-BOP	½" - 14 NPTF	Steel	1.94	49.3	1.17	29.7	1-1/16	0.11	-	25
½	H4F4-SS-BOP	½" - 14 NPTF	316 SS	1.94	49.3	1.17	29.7	1-1/16	0.11	-	25
¾	H6F6-BOP	¾" - 14 NPTF	Steel	2.41	61.2	1.44	36.6	1-5/16	0.21	-	10
¾	H6F6-SS-BOP	¾" - 14 NPTF	316 SS	2.41	61.2	1.44	36.6	1-5/16	0.21	-	10
1	H8F8-BOP	1" - 11 ½ NPTF	Steel	2.87	72.9	1.79	45.5	1%	0.35	-	10
1	H8F8-SS-BOP	1" - 11 ½ NPTF	316 SS	2.87	72.9	1.79	45.5	1%	0.35	-	10

## HS-Series ISO-B Steam Interchange

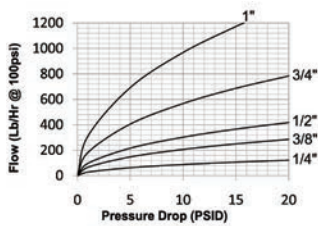

<b>Features:</b>	<ul style="list-style-type: none"> <li>HS-Series couplers and nipples are fully compliant with the parameters outlined in ISO7241 Series B</li> <li>Flanged sleeves are designed for ease of sleeve operation while wearing gloves during connection and disconnection</li> <li>EPDM steam body and valve seals are formulated to withstand continuous steam service</li> <li>Brass couplers have a redundant O-ring to maximise service life and provide additional sealing integrity</li> </ul>
<b>Materials:</b>	<ul style="list-style-type: none"> <li>Machined components are manufactured using solid steel, brass, or 303 stainless steel bar stock</li> <li>Stainless steel balls, retaining rings, and springs maximise corrosion resistance and extend service life</li> <li>Steel components are plated using ROHS-compliant trivalent chrome</li> <li>Steel nipples are hardened to provide heavy-duty performance and resist brinelling</li> <li>All couplers have a steel steam-sleeve as standard</li> </ul>
<b>Seal Components:</b>	<ul style="list-style-type: none"> <li>EPDM steam-grade seals are standard, providing a temperature range of -57°C to 204°C (70°F to 399°F)</li> <li>Couplers have a redundant O-ring sealing system (Dual O-rings with PTFE back-up)</li> <li>Valve seals are crimped in place to maintain integrity during excessive flow conditions</li> </ul>
<b>Interchange Data:</b>	<ul style="list-style-type: none"> <li>Interchangeable to ISO7241 Series 'B'</li> <li>Parker 60-Series Steam Couplings</li> </ul>

### Rated Pressure Chart:

Size (inch)	Brass Coupler / Plug				Brass Coupler / Steel Plug			
	Max Working		Coupled Burst		Max Working		Coupled Burst	
	PSI	Bar	PSI	Bar	PSI	Bar	PSI	Bar
1/4	200	14	14,500	1000	200	14	14,500	1000
3/8	200	14	12,000	800	200	14	14,500	1000
1/2	200	14	11,500	750	200	14	14,500	1000
3/4	200	14	9,280	640	200	14	9,280	640
1	200	14	5,800	400	200	14	5,800	400

Size (inch)	Brass Coupler / 303 SS Plug				303 SS Coupler / Plug			
	Max Working		Coupled Burst		Max Working		Coupled Burst	
	PSI	Bar	PSI	Bar	PSI	Bar	PSI	Bar
1/4	200	14	14,500	1000	200	14	31,500	2150
3/8	200	14	14,500	1000	200	14	26,500	1800
1/2	200	14	14,500	1000	200	14	27,500	1900
3/4	200	14	9,280	640	200	14	16,000	1100
1	200	14	5,800	400	200	14	15,000	1000

**Please Note** (operating specifications): Operating pressure has been calculated using saturated steam at 170°C (338°F) for general-purpose applications. Operating temperature is related to continuous steam service, with an intermittent maximum temperature of 204°C (400°F). For advanced operating pressure or super-heated steam specifications, contact the factory for further information.

Interchange Standards					Functional Parameters				
Size (inch)	US Military	US Government	International Standards	ANSI / NFPA Standards	Locking Ball Qty	Air Inclusion	Fluid Loss	Vacuum inch HG	Flow (Lps/hr) ΔP = 10 PSI
1/4	-	-	ISO7241-B	B93.113M-B	8	1.1cc	0.9cc	27.4	88
3/8	-	-	ISO7241-B	B93.113M-B	9	2.6cc	1.8cc	27.4	206
1/2	-	-	ISO7241-B	B93.113M-B	9	3.8cc	2.9cc	27.4	302
3/4	-	-	ISO7241-B	B93.113M-B	12	10.8cc	9.7cc	27.4	567
1	-	-	ISO7241-B	B93.113M-B	12	15.9cc	15.3cc	27.4	968

HS-Series Interchange		
Size (inch)	Parker	Hansen
All Sizes	60 Series	HK Series

**DO NOT DISCONNECT STEAM COUPLINGS WHILE UNDER PRESSURE!**  
 Maximum operating temperature for steam service couplings is 204°C (400°F). Be sure to use safety chains, or equivalent means, to prevent the line from thrashing around in case the coupling becomes disconnected.

# Hydraulic & Pneumatic

## HS-Series Couplers

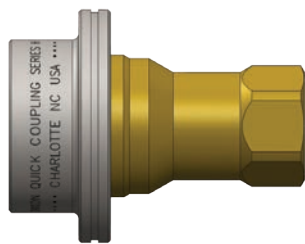

Female Thread

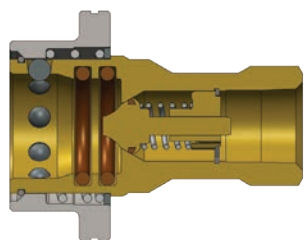

Size (inch)	Part No.	Thread Size (inch)	Body Material	Weight (kg)	Pkg Qty	
					Bag	Box
¼	2HSF2-B	¼ - 18 NPTF	Brass	0.13	5	50
¼	2HSF2-S	¼ - 18 NPTF	303 SS	0.13	5	50
¼	2HSBF2-B	¼ - 19 BSPP	Brass	0.13	5	50
¼	2HSBF2-S	¼ - 19 BSPP	303 SS	0.13	5	50
⅜	3HSF3-B	⅜ - 18 NPTF	Brass	0.22	-	50
⅜	3HSF3-S	⅜ - 18 NPTF	303 SS	0.22	-	50
⅜	3HSBF3-B	⅜ - 19 BSPP	Brass	0.22	-	50
⅜	3HSBF3-S	⅜ - 19 BSPP	303 SS	0.22	-	50
½	4HSF4-B	½ - 14 NPTF	Brass	0.34	-	25
½	4HSF4-S	½ - 14 NPTF	303 SS	0.34	-	25
½	4HSBF4-B	½ - 14 BSPP	Brass	0.34	-	25
½	4HSBF4-S	½ - 14 BSPP	303 SS	0.34	-	25
¾	6HSF6-B	¾ - 14 NPTF	Brass	0.59	-	10
¾	6HSF6-S	¾ - 14 NPTF	303 SS	0.59	-	10
¾	6HSBF6-B	¾ - 14 BSPP	Brass	0.59	-	10
¾	6HSBF6-S	¾ - 14 BSPP	303 SS	0.59	-	10
1	8HSF8-B	1 - 11½ NPTF	Brass	0.88	-	10
1	8HSF8-S	1 - 11½ NPTF	303 SS	0.88	-	10
1	8HSBF8-B	1 - 11 BSPP	Brass	0.88	-	10
1	8HSBF8-S	1 - 11 BSPP	303 SS	0.88	-	10

## HS-Series Nipples



Female Thread

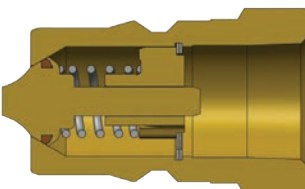

Size (inch)	Part No.	Thread Size (inch)	Body Material	Weight (kg)	Pkg Qty	
					Bag	Box
¼	HS2F2	¼ - 18 NPTF	Steel	0.03	10	50
¼	HS2F2-B	¼ - 18 NPTF	Brass	0.03	10	50
¼	HS2F2-S	¼ - 18 NPTF	303 SS	0.03	10	50
¼	HS2BF2	¼ - 19 BSPP	Steel	0.03	10	50
¼	HS2BF2-B	¼ - 19 BSPP	Brass	0.03	10	50
¼	HS2BF2-S	¼ - 19 BSPP	303 SS	0.03	10	50
⅜	HS3F3	⅜ - 18 NPTF	Steel	0.06	10	50
⅜	HS3F3-B	⅜ - 18 NPTF	Brass	0.06	10	50
⅜	HS3F3-S	⅜ - 18 NPTF	303 SS	0.06	10	50
⅜	HS3BF3	⅜ - 19 BSPP	Steel	0.06	10	50
⅜	HS3BF3-B	⅜ - 19 BSPP	Brass	0.06	10	50
⅜	HS3BF3-S	⅜ - 19 BSPP	303 SS	0.06	10	50
½	HS4F4	½ - 14 NPTF	Steel	0.11	5	25
½	HS4F4-B	½ - 14 NPTF	Brass	0.11	5	25
½	HS4F4-S	½ - 14 NPTF	303 SS	0.11	5	25
½	HS4BF4	½ - 14 BSPP	Steel	0.11	5	25
½	HS4BF4-B	½ - 14 BSPP	Brass	0.11	5	25
½	HS4BF4-S	½ - 14 BSPP	303 SS	0.11	5	25
¾	HS6F6	¾ - 14 NPTF	Steel	0.21	-	10
¾	HS6F6-B	¾ - 14 NPTF	Brass	0.21	-	10
¾	HS6BF6	¾ - 14 BSPP	Steel	0.21	-	10
¾	HS6BF6-B	¾ - 14 BSPP	Brass	0.21	-	10
¾	HS6BF6-S	¾ - 14 BSPP	303 SS	0.21	-	10
1	HS8F8	1 - 11½ NPTF	Steel	0.34	-	10
1	HS8F8-B	1 - 11½ NPTF	Brass	0.34	-	10
1	HS8F8-S	1 - 11½ NPTF	303 SS	0.34	-	10
1	HS8BF8	1 - 11 BSPP	Steel	0.34	-	10
1	HS8BF8-B	1 - 11 BSPP	Brass	0.34	-	10
1	HS8BF8-S	1 - 11 BSPP	303 SS	0.34	-	10

- NPTF and ORB thread styles also available
- A complete range of seal options are available



Note: Maximum working pressure has been calculated using saturated steam at 194°C (381°F) for general-purpose continuous steam service. For advanced operating pressure or super-heated steam applications, contact Dixon™ for further information.

FOR TECHNICAL GUIDELINES PLEASE REFER TO PAGE 193

## H-Series ISO-B Food-Grade Couplings

**Features:**

- H-Series couplers and nipples are fully compliant with the parameters outlined in ISO7241 Series B
- FKM™ seals are FDA approved for food service applications, such as fryers and fryer-oil filtering equipment
- Large diameter flanged coupler sleeves will prevent damage when dropped and are easier to operate with gloves on
- Couplings of steel with nickel plating, 303 stainless steel, and 316 stainless steel fulfill the requirements of various food service applications

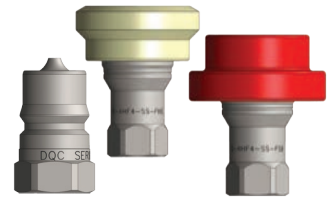

Size (inch)	Steel Coupler / Plug				Brass Coupler / Plug			
	Max Working		Coupled Burst		Max Working		Coupled Burst	
	PSI	Bar	PSI	Bar	PSI	Bar	PSI	Bar
½	4,000	275	16,000	1100	2,500	175	11,500	750

Size (inch)	303 Stainless Coupler / Plug				316 Stainless Coupler / Plug			
	Max Working		Coupled Burst		Max Working		Coupled Burst	
	PSI	Bar	PSI	Bar	PSI	Bar	PSI	Bar
½	3,500	240	27,500	1900	3,500	240	22,000	1500

Interchange Standards					Functional Parameters				
Size (inch)	US Military	US Government	International Standards	ANSI / NFPA Standards	Locking Ball Qty	Air Inclusion	Fluid Loss	Vacuum inch HG	Flow (Lpm) ΔP = 22 PSI
½	-	-	ISO7241-B	B93.113M-B	9	3.8cc	2.9cc	27.4	57

HFG-Series Interchange						
Size (inch)	Parker	Aeroquip	Snap-Tite	Stucchi	Faster	Hansen
½	60 Series	FD45	72 Series	IRB / IRBO / IRBX	HNV Series	HK Series

## H-Series Silicone Flanged Couplers

Size (inch)	Part No.	Thread Size (inch)	Body Material	Weight (kg)	Pkg Qty	
					Bag	Box
½	D-4HF4-S-FSB	½ - 14 NPTF	303 SS	0.39	5	25
½	D-4HF4-SS-FSB	½ - 14 NPTF	316 SS	0.40	5	25



Female Thread

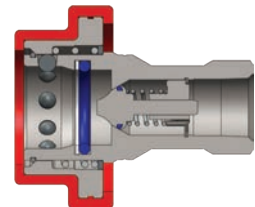

## H-Series Nylon Flanged Couplers

Size (inch)	Part No.	Thread Size (inch)	Body Material	Weight (kg)	Pkg Qty	
					Bag	Box
½	D-4HF4-S-FNS	½ - 14 NPTF	303 SS	0.39	5	25
½	D-4HF4-SS-FNS	½ - 14 NPTF	316 SS	0.40	5	25

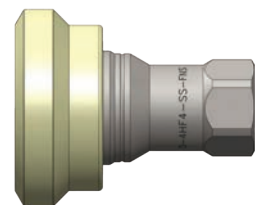

Female Thread

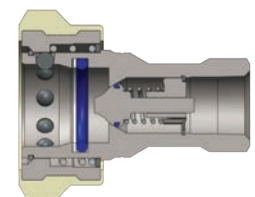

- ORB thread styles also available.
- A complete range of seal options are available



The 'FSB' and 'FNS' coupler sleeves have a nickel plated steel core that is used to stabilize and strengthen the outer silicone (FSB) or nylon (FNS) bumpers. This nickel plated steel core is used for all couplers in this series but does not affect corrosion resistance for the 303SS or 316SS coupler models.



# Hydraulic & Pneumatic

## H-Series Steel Mill Slide Gate Couplers



Female Thread

Size (inch)	Part No.	Thread Size (inch)	Body Material	Weight (kg)	Pkg Qty	
					Bag	Box
½	4HF4-HV	½ - 14 NPTF	Steel	0.30	5	25

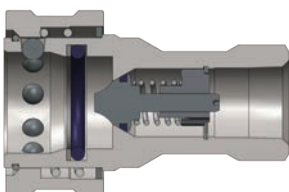

## H-Series Steel Mill Slide Gate Nipples

Size (inch)	Part No.	Thread Size (inch)	Body Material	Weight (kg)	Pkg Qty	
					Bag	Box
½	H4F4-HV	½ - 14 NPTF	Steel	0.13	5	25

## H-Series Nipples



Female Thread

Size (inch)	Part No.	Thread Size NPTF (inch)	Body Material	Weight (kg)	Pkg Qty	
					Bag	Box
½	D-H4F4-SV-8	½ - 14	Steel	0.39	5	25
½	D-H4F4-S	½ - 14	303 SS	0.39	5	25
½	D-H4F4-SS	½ - 14	316 SS	0.40	5	25

- NPTF and ORB thread styles also available
- A complete range of seal options are available

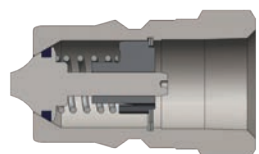

FOR TECHNICAL GUIDELINES PLEASE REFER TO PAGE 195

## K-Series ISO7241 Series A

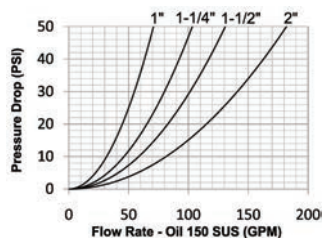
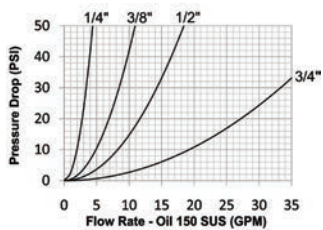

<b>Materials:</b>	<ul style="list-style-type: none"> <li>Machined components are manufactured using solid steel bar stock</li> <li>Stainless steel balls, retaining rings, and springs maximise corrosion resistance and extend service life</li> <li>Steel componentry is plated using ROHS-compliant trivalent chrome</li> <li>Steel coupler sleeves are hardened to resist deformation and maximise service life</li> <li>Steel nipples are hardened to provide heavy-duty performance and resist brinelling</li> </ul>
<b>Seal Components:</b>	<ul style="list-style-type: none"> <li>Nitrile (Buna-N) seals are standard, providing a temperature range of <b>-40°C to 121°C (-40°F to 249°F)</b></li> <li>Couplers have a PTFE anti-extrusion ring</li> <li>Valve seals are crimped in place to maintain integrity during excessive flow conditions and pressurised connection</li> </ul>
<b>Interchange Data:</b>	<ul style="list-style-type: none"> <li>Interchangeable to ISO7241 Series A</li> <li>Parker 6600-Series, Aeroquip/Eaton FD56 (5600)</li> <li>Faster ANV, Hansen HA15000, Safeway S56-Series, Ryco 80, 81, 82, 85 &amp; 86 Series</li> </ul>
<b>Standards:</b>	<ul style="list-style-type: none"> <li>K-Series couplers and nipples are compliant with the parameters outlined in ISO7241 Series A</li> </ul>

Size (inch)	Steel Coupler / Plug			
	Max Working		Coupled Burst	
	PSI	Bar	PSI	Bar
1/4	5,000	345	18,270	1200
3/8	4,000	275	18,270	1200
1/2	4,000	275	16,500	1100
3/4	4,000	275	14,800	1000
1	4,000	275	12,400	850
1 1/4	3,000	200	12,600	850
1 1/2	3,000	200	12,600	850
2	1,450	100	5,800	400

Interchange Standards					Functional Parameters				
Size (inch)	US Military	US Government	International Standards	ANSI / NFPA Standards	Locking Ball Qty	Air Inclusion	Fluid Loss	Vacuum inch HG	Flow (Lpm) ΔP = 22 PSI
1/4	-	-	ISO7241-A	B93.113M-A	6	0.6cc	0.3cc	26.5	11
3/8	-	-	ISO7241-A	B93.113M-A	9	2.6cc	1.8cc	26.5	26
1/2	-	-	ISO7241-A	B93.113M-A	9	3.8cc	2.9cc	26.5	45
3/4	-	-	ISO7241-A	B93.113M-A	12	10.8cc	9.7cc	26.5	106
1	-	-	ISO7241-A	B93.113M-A	15	15.9cc	15.3cc	26.5	190
1 1/4	-	-	ISO7241-A	B93.113M-A	16	31.7cc	29.1cc	26.5	265
1 1/2	-	-	ISO7241-A	B93.113M-A	16	56.4cc	52.2cc	26.5	341
2	-	-	ISO7241-A	B93.113M-A	15	N/A	N/A	26.5	454

K-Series Interchange					
Size (inch)	Parker	Aeroquip	Faster	Hansen	Safeway
1/4	Series 6600	FD56 (5600)	ANV	HA 15000	S56-Series
3/8	Series 6600	FD56 (5600)	ANV	HA 15000	S56-Series
1/2	Series 6600	FD56 (5600)	ANV	HA 15000	S56-Series
3/4	Series 6600	FD56 (5600)	ANV	HA 15000	S56-Series
1	Series 6600	FD56 (5600)	ANV	HA 15000	S56-Series
1 1/4	-	-	ANV	HA 15000	S56-Series
1 1/2	-	-	ANV	HA 15000	S56-Series
2	-	-	ANV	HA 15000	S56-Series

- NPTF and ORB thread styles also available
- A complete range of seal options are available

### K-Series Interchange - Hermaphrodite Dust Plugs & Caps



Size (inch)	Part No.	Body Material	Pkg Qty	
			Bag	Box
¼	2KDP-K2DC	Nitrile	10	50
⅜	3KDP-K3DC	Nitrile	10	50
½	6KDP-K6DC	Nitrile	5	25
1	8KDP-K8DC	Nitrile	5	25

### K-Series Interchange - Colour-Coded Dust Plugs



Size (inch)	Part No.	Colour	Body Material	Pkg Qty	
				Bag	Box
½	4KDP	Black	Nitrile	10	50
½	4K-R-DP	Red	Nitrile	10	50
½	4K-O-DP	Orange	Nitrile	10	50
½	4K-Y-DP	Yellow	Nitrile	10	50
½	4K-G-DP	Green	Nitrile	10	50
½	4K-B-DP	Blue	Nitrile	10	50

E

### K-Series Interchange - Colour Coded Dust Caps



Size (inch)	Part No.	Colour	Body Material	Pkg Qty	
				Bag	Box
½	K4DC	Black	Nitrile	10	50
½	K4-R-DC	Red	Nitrile	10	50
½	K4-O-DC	Orange	Nitrile	10	50
½	K4-Y-DC	Yellow	Nitrile	10	50
½	K4-G-DC	Green	Nitrile	10	50
½	K4-B-DC	Blue	Nitrile	10	50

### K-Series Interchange - Coupler Seal Kits

Size (inch)	Part No.	Coupler Style	Seal Material	Seal Kit Contents	Pkg Qty	
					Bag	Box
¼	2K-SKIT	All	Nitrile	O-ring & PTFE Anti-Extrusion Ring	25	200
⅜	3K-SKIT	All	Nitrile	O-ring & PTFE Anti-Extrusion Ring	25	200
½	4K-SKIT	All	Nitrile	O-ring & PTFE Anti-Extrusion Ring	25	200
¾	6K-SKIT	All	Nitrile	O-ring & PTFE Anti-Extrusion Ring	25	200
1	8K-SKIT	All	Nitrile	O-ring & PTFE Anti-Extrusion Ring	25	200
1¼	10K-SKIT	All	Nitrile	O-ring & PTFE Anti-Extrusion Ring	10	50
1½	12K-SKIT	All	Nitrile	O-ring & PTFE Anti-Extrusion Ring	10	50
2	16K-SKIT	All	Nitrile	O-ring & PTFE Anti-Extrusion Ring	10	50

- NPTF and ORB thread styles also available
- A complete range of seal options are available

FOR TECHNICAL GUIDELINES PLEASE REFER TO PAGE 197



## K-Series Interchange - Couplers

Size (inch)	Part No.	Thread Size (inch)	Body Material	Weight (kg)	Pkg Qty	
					Bag	Box
¼	2KF1	¼ - 27 NPTF	Steel	0.12	10	50
¼	2KF2	¼ - 18 NPTF	Steel	0.12	10	50
¼	2KF2-SS	¼ - 18 NPTF	316 SS	0.09	10	50
¼	2KBF2	¼ - 19 BSPP	Steel	0.12	10	50
¼	2KBF2-SS	¼ - 19 BSPP	316 SS	0.08	10	50
¼	2KOF2	⅞ - 20 ORB	Steel	0.11	10	50
⅜	3KF3	⅜ - 18 NPTF	Steel	0.18	10	50
⅜	3KF3-SS	⅜ - 18 NPTF	316 SS	0.15	10	50
⅜	3KBF3	⅜ - 19 BSPP	Steel	0.18	10	50
⅜	3KBF3-SS	⅜ - 19 BSPP	316 SS	0.15	10	50
⅜	3KOF3	⅞ - 18 ORB	Steel	0.18	10	50
½	4KF4	½ - 14 NPTF	Steel	0.30	5	25
½	4KF4-SS	½ - 14 NPTF	316 SS	0.25	5	25
½	4KBF4	½ - 14 BSPP	Steel	0.30	5	25
½	4KBF4-SS	½ - 14 BSPP	316 SS	0.25	5	25
½	4KOF4	¾ - 16 ORB	Steel	0.31	5	25
½	4KOF5	⅞ - 14 ORB	Steel	0.30	5	25
½	4KF6	¾ - 14 NPTF	Steel	0.32	5	25

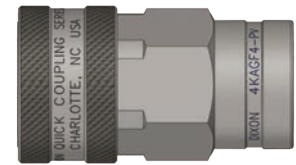

Female Thread

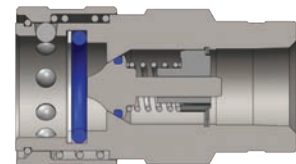

Size (inch)	Part No.	Thread Size (inch)	Body Material	Weight (kg)	Pkg Qty	
					Bag	Box
¾	6KF6	¾ - 14 NPTF	Steel	0.86	-	10
¾	6KF6-SS	¾ - 14 NPTF	316 SS	0.45	-	10
¾	6KBF6	¾ - 14 BSPP	Steel	0.86	-	10
¾	6KBF6-SS	¾ - 14 BSPP	316 SS	0.46	-	10
¾	6KOF6	1⅞ - 12 ORB	Steel	0.86	-	10
1	8KF8	1 - 11½ NPTF	Steel	0.97	-	10
1	8KBF8	1 - 11 BSPP	Steel	0.97	-	10
1	8KOF8	1⅞ - 12 ORB	Steel	0.97	-	10



Female Thread

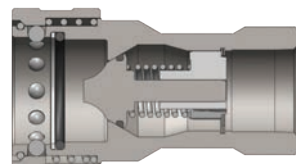

Size (inch)	Part No.	Thread Size (inch)	Body Material	Weight (kg)	Pkg Qty	
					Bag	Box
1¼	10KF10	1¼ - 11½ NPT	Steel	1.33	-	10
1¼	10KBF10	1¼ - 11 BSPP	Steel	1.33	-	10
1½	12KF12	1½ - 11½ NPT	Steel	2.16	-	1
1½	12KBF12	1½ - 11 BSPP	Steel	2.17	-	1
2	16KF16	2 - 11½ NPT	Steel	3.85	-	1
2	16KBF16	2 - 11 BSPP	Steel	3.85	-	1



Female Thread

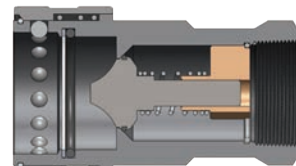

- NPTF and ORB thread styles also available
- A complete range of seal options are available

FOR TECHNICAL GUIDELINES PLEASE REFER TO PAGE 197



## K-Series Interchange - Nipples



Female Thread

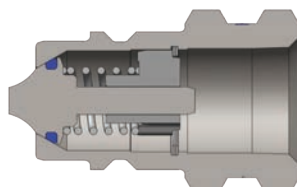

Size (inch)	Part No.	Thread Size (inch)	Body Material	Weight (kg)	Pkg Qty	
					Bag	Box
1/4	K2F1	1/8 - 27 NPTF	Steel	0.03	10	50
1/4	K2F2	1/4 - 18 NPTF	Steel	0.03	10	50
1/4	K2F2-SS	1/4 - 18 NPTF	316 SS	0.03	10	50
1/4	K2BF2	1/4 - 19 BSPP	Steel	0.03	10	50
1/4	K2BF2-SS	1/4 - 19 BSPP	316 SS	0.03	10	50
1/4	K2OF2	7/16 - 20 ORB	Steel	0.03	10	50
3/8	K3F3	3/8 - 18 NPTF	Steel	0.05	10	50
3/8	K3F3-SS	3/8 - 18 NPTF	316 SS	0.06	10	50
3/8	K3BF3	3/8 - 19 BSPP	Steel	0.05	10	50
3/8	K3BF3-SS	3/8 - 19 BSPP	316 SS	0.06	10	50
3/8	K3OF3	3/8 - 18 ORB	Steel	0.06	10	50
3/8	K4F4-SS	3/8 - 18 ORB	316 SS	0.10	10	50
1/2	K4F4	1/2 - 14 NPTF	Steel	0.09	5	25
1/2	K4BF4	1/2 - 14 BSPP	Steel	0.09	5	25
1/2	K4BF4-SS	1/2 - 14 BSPP	316 SS	0.10	5	25
1/2	K4OF4	3/4 - 16 ORB	Steel	0.10	5	25
1/2	K4OF5	7/8 - 14 ORB	Steel	0.09	5	25

E



Female Thread

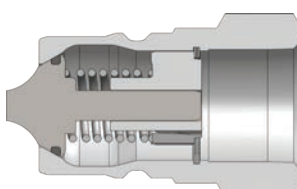

Size (inch)	Part No.	Thread Size (inch)	Body Material	Weight (kg)	Pkg Qty	
					Bag	Box
3/4	K6F6	3/4 - 14 NPTF	Steel	0.22	-	10
3/4	K6F6-SS	3/4 - 14 NPTF	316 SS	0.22	-	10
3/4	K6BF6	3/4 - 14 BSPP	Steel	0.22	-	10
3/4	K6BF6-SS	3/4 - 14 BSPP	316 SS	0.20	-	10
3/4	K6OF6	1 1/16 - 12 ORB	Steel	0.21	-	10
1	K8F8	1 - 11 1/2 NPTF	Steel	0.34	-	10
1	K8F8-SS	1 - 11 1/2 NPTF	316 SS	0.32	-	10
1	K8BF8	1 - 11 BSPP	Steel	0.34	-	10
1	K8BF8-SS	1 - 11 BSPP	316 SS	0.31	-	10
1	K8OF8	1 1/16 - 12 ORB	Steel	0.33	-	10
1 1/4	K10F10	1 1/4 - 11 1/2 NPT	Steel	0.57	-	10
1 1/4	K10BF10	1 1/4 - 11 BSPP	Steel	0.57	-	10
1 1/2	K12F12	1 1/2 - 11 1/2 NPT	Steel	0.93	-	1
1 1/2	K12BF12	1 1/2 - 11 BSPP	Steel	0.93	-	1
2	K16F16	2 - 11 1/2 NPT	Steel	1.65	-	1
2	K16BF16	2 - 11 BSPP	Steel	1.65	-	1

## K-Series Profiles

- NPTF and ORB thread styles also available
- A complete range of seal options are available

Body Size (inch)	A (mm)	B (mm)
1/4	7/16	1/4
3/8	11/16	3/8
1/2	13/16	3/8
3/4	1 1/8	5/8
1	1 3/8	13/16
1-1/4	1-11/16	1
1-1/2	2-1/16	1-3/16
2	2-7/16	1-5/16

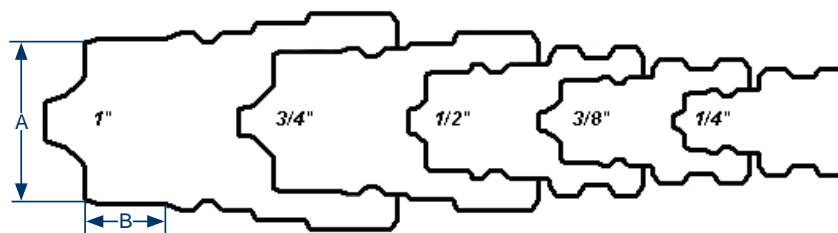

FOR TECHNICAL GUIDELINES PLEASE REFER TO PAGE 197

## W-Series Wingstyle Interchange

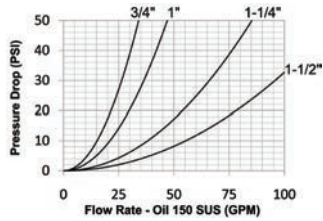

<b>Materials:</b>	<ul style="list-style-type: none"> <li>Machined components are manufactured using solid steel and brass bar stock</li> <li>Stainless steel retaining rings and springs maximise corrosion resistance and extend service life</li> <li>Steel componentry is plated using ROHS-compliant trivalent chrome</li> <li>Rugged steel cast wing nut for threaded connect and disconnect operation</li> <li>For steel models, coupler valve sleeve and nipple valve are constructed of brass</li> </ul>
<b>Seal Components:</b>	<ul style="list-style-type: none"> <li>Nitrile (Buna-N) seals are standard, providing a temperature range of <b>-40°C to 121°C (-40°F to 249°F)</b></li> <li>3/4" and 1" couplings have a PTFE back-up ring on the valve sleeve to extend service life</li> <li>Main coupler valve has a bonded face-seal to improve seal integrity during pressurised connection / disconnection</li> <li>3/4" and 1 1/2" nipple valve seal is bonded to the valve face to improve seal integrity and prolong service life</li> <li>External O-ring on plug indicates full connection and acts as a contamination shield in connected mode</li> <li>Redundant O-ring on the coupler body will engage nipple for secondary sealing support</li> </ul>
<b>Interchange Data:</b>	<ul style="list-style-type: none"> <li>Aeroquip 5100-Series, Parker 6100-Series</li> <li>Snap-Tite 78-Series, Faster Series-FB, Safeway S51-Series</li> </ul>

- NPTF and ORB thread styles also available.
- A complete range of seal options are available.

Size (inch)	Coupler / Plug			
	Max Working		Coupled Burst	
	PSI	Bar	PSI	Bar
3/4	3,000	200	12,300	850
1	3,000	200	14,100	1000
1 1/4	2,750	190	8,800	600
1 1/2	2,500	170	8,800	600

Interchange Standards					Functional Parameters				
Size (inch)	US Military	US Government	International Standards	ANSI / NFPA Standards	Locking Mechanism	Air Inclusion	Fluid Loss	Vacuum inch HG	Flow (Lpm) ΔP = 32 PSI
3/4	-	-	-	-	Threaded	0.34cc	0.26cc	27.4	106
1	-	-	-	-	Threaded	0.50cc	0.35cc	27.4	151
1 1/4	-	-	-	-	Threaded	0.68cc	0.70cc	27.4	265
1 1/2	-	-	-	-	Threaded	0.60cc	0.94cc	27.4	379

W Series Interchange				
Size (inch)	Parker	Aeroquip	Snap - Tite	Faster
3/4	6100 Series	5100 Series	Series '78'	-
1	6100 Series	5100 Series	Series '78'	Series 'FB'
1 1/4	6100 Series	5100 Series	Series '78'	Series 'FB'
1 1/2	6100 Series	5100 Series	Series '78'	Series 'FB'

## W-Series Thread Together- Coupler Rigid Dust Plugs

Size (inch)	Part No.	Cap Lanyard	Body Material	Weight (kg)	Pkg Qty	
					Bag	Box
1/4	2WDP	Steel Cable	Steel	0.06	10	50
3/8	3WDP	Steel Cable	Steel	0.09	10	50
3/4	6WDP	Steel Cable	Steel	0.14	10	50
1	8WDP	Steel Cable	Steel	0.22	10	50
1 1/4	10WDP	Steel Cable	Steel	0.28	5	25
1 1/2	12WDP	Steel Cable	Steel	0.54	5	25



## W-Series Thread Together - Nipple Rigid Dust Caps

Size (inch)	Part No.	Cap Lanyard	Body Material	Weight (kg)	Pkg Qty	
					Bag	Box
1/4	W2DC	Steel Cable	Steel	0.06	10	50
3/8	W3DC	Steel Cable	Steel	0.07	10	50
3/4	W6DC	Steel Cable	Steel	0.16	10	50
1	W8DC	Steel Cable	Steel	0.16	10	50
1 1/4	W10DC	Steel Cable	Steel	0.28	5	25
1 1/2	W12DC	Steel Cable	Steel	0.47	5	25



**!** Although the wingstyle couplings are able to connect and disconnect while under pressure, it is recommended that hydraulic power supply be de-energised during connection to ensure operator safety. If it is not possible to de-energise the circuit, operators must be aware of their surroundings to ensure that an attachment or tool does not put them at risk, once hydraulic power is applied during the connection process. W-Series couplings are not recommended for continuous hydraulic impulse applications at rated pressures.



## W-Series Hydraulic Couplings

### Wingstyle Socket Features

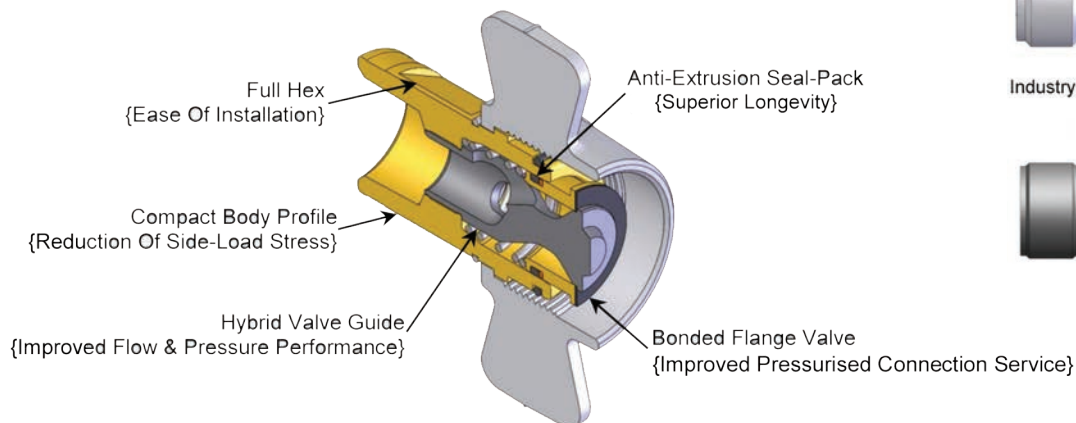

Industry 'Norm' Tubular Valve Guide  
Versus  
Hybrid Valve Guide



### Wingstyle Plug Features

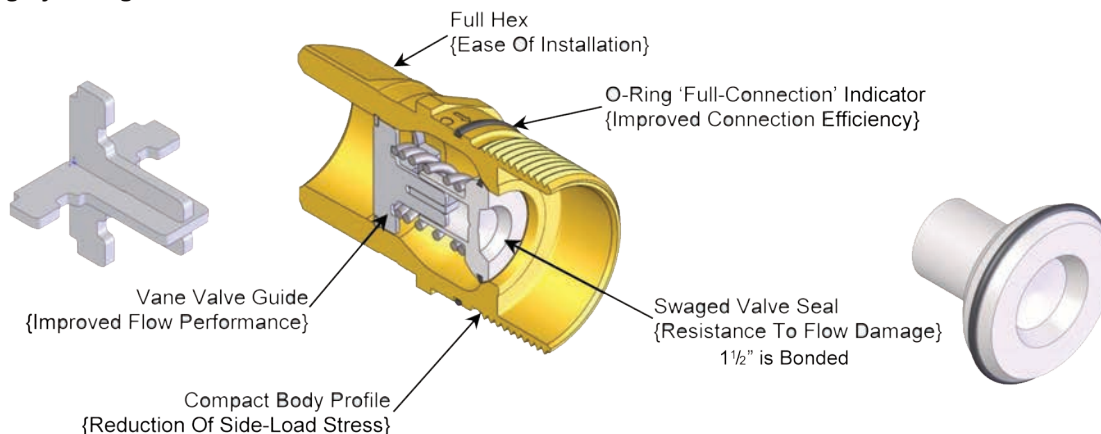

E

Body Size (Inch)	A (mm)	B (mm)
1/4	20.64	15.88
3/8	25.40	19.05
1/2	24.93	20.64
1	44.45	28.58
1 1/4	50.80	31.75
1 1/2	60.33	38.10

## W-Series Profiles

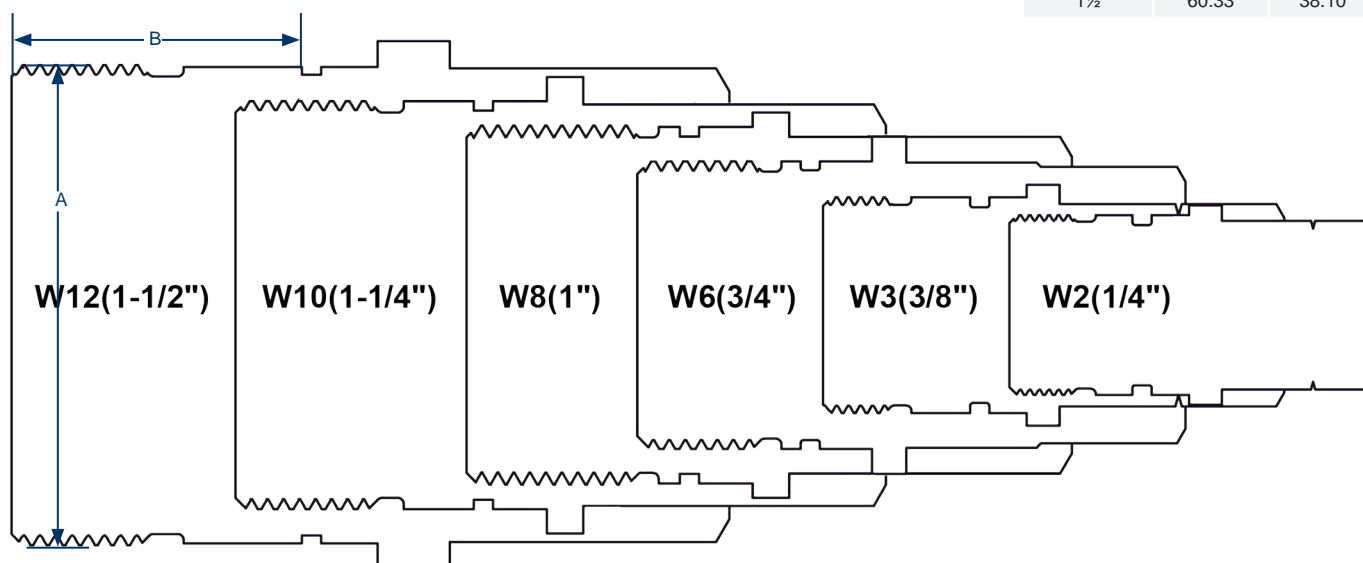

## W-Series Thread Together - Wingstyle Coupler Repair Kits

Size (inch)	Part No.	Coupler Style	Seal Material	Repair Kits Contents	Pkg Qty	
					Bag	Box
¾	6W-RKIT-V2	All	Nitrile	Bonded Valve, O-rings & PTFE Backup	1	25
1	8W-RKIT-V2	All	Nitrile	Bonded Valve, O-rings & PTFE Backup	1	25
1¼	10W-RKIT-V2	All	Nitrile	Bonded Valve, O-rings & PTFE Backup	1	25
1½	12W-RKIT-V2	All	Nitrile	Bonded Valve, O-rings & PTFE Backup	1	25

## W-Series Thread Together - Wingstyle Nipple Repair Kits

Size (inch)	Part No.	Coupler Style	Seal Material	Repair Kits Contents	Bag Qty	Pkg Qty
¾	W6-RKIT-V2	All	Nitrile	Valve Assembly & O-ring	1	25
1	W8-RKIT-V2	All	Nitrile	Valve Assembly & O-ring	1	25
1¼	W10-RKIT-V2	All	Nitrile	Valve Assembly & O-ring	1	25
1½	W12-RKIT-V2	All	Nitrile	Valve Assembly & O-ring	1	25

## W-Series Thread Together - Wing Nut Couplers

Size (inch)	Part No.	Thread Size (inch)	Body Material	Weight (kg)	Pkg Qty
¾	6WF4-B	½ - 14 NPTF	Brass	0.59	10
¾	6WBF4-B	½ - 14 BSPP	Brass	0.59	10
¾	6WF6-B	¾ - 14 NPTF	Brass	0.59	10
¾	6WBF6-B	¾ - 14 BSPP	Brass	0.59	10
1	8WF8-B	1 - 11½ NPTF	Brass	0.86	10
1	8WF8	1 - 11½ NPTF	Steel	0.86	10
1	8WBF8-B	1 - 11 BSPP	Brass	0.86	10
1¼	10WF10-B	1¼ - 11½ NPTF	Brass	1.25	5
1¼	10WBF10-B	1¼ - 11 BSPP	Brass	1.25	5
1½	12WF12-B	1½ - 11½ NPTF	Brass	1.60	5
1½	12WBF12-B	1½ - 11 BSPP	Brass	1.60	5



Female Thread

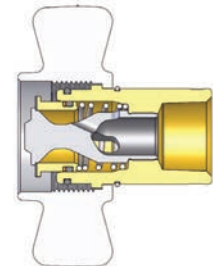

## W-Series Thread Together - Hex Nut Couplers

Size (inch)	Part No.	Thread Size (inch)	Body Material	Weight (kg)	Pkg Qty
¾	6WF4-B-HN	½ - 14 NPTF	Brass	0.48	10
¾	6WBF4-B-HN	½ - 14 BSPP	Brass	0.49	10
¾	6WF6-B-HN	¾ - 14 NPTF	Brass	0.48	10
¾	6WBF6-B-HN	¾ - 14 BSPP	Brass	0.49	10
1	8WF8-B-HN	1 - 11½ NPTF	Brass	0.74	10
1	8WBF8-B-HN	1 - 11 BSPP	Brass	0.74	10
1¼	10WF10-B-HN	1¼ - 11½ NPTF	Brass	1.12	5
1¼	10WBF10-B-HN	1¼ - 11 BSPP	Brass	1.12	5
1½	12WF12-B-HN	1½ - 11½ NPTF	Brass	1.43	5
1½	12WBF12-B-HN	1½ - 11 BSPP	Brass	1.43	5

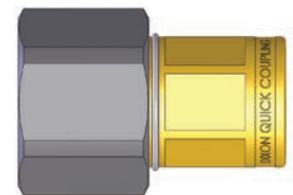

Female Thread

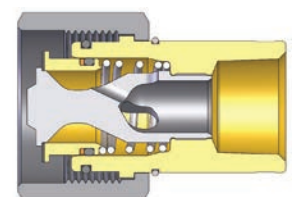

FOR TECHNICAL GUIDELINES PLEASE REFER TO PAGE 201

# Hydraulic & Pneumatic

## W-Series Thread Together - Nipples



Female Thread

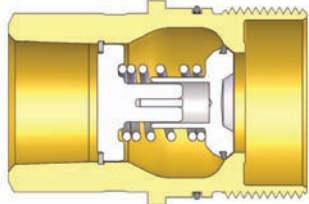

Size (inch)	Part No.	Thread Size (inch)	Body Material	Weight (kg)	Pkg Qty
3/4	W6F4-B	1/2 - 14 NPTF	Brass	0.37	10
3/4	W6BF4-B	1/2 - 14 BSPP	Brass	0.37	10
3/4	W6F6-B	3/4 - 14 NPTF	Brass	0.34	10
3/4	W6BF6-B	3/4 - 14 BSPP	Brass	0.34	10
1	W8F8-B	1 - 11 1/2 NPTF	Brass	0.59	10
1	W8F8	1 - 11 1/2 NPTF	Steel	0.59	10
1	W8BF8-B	1 - 11 BSPP	Brass	0.59	10
1 1/4	W10F10-B	1 1/4 - 11 1/2 NPTF	Brass	0.75	5
1 1/4	W10BF10-B	1 1/4 - 11 BSPP	Brass	0.75	5
1 1/2	W12F12-B	1 1/2 - 11 1/2 NPTF	Brass	1.18	5
1 1/2	W12BF12-B	1 1/2 - 11 BSPP	Brass	1.18	5

## W-Series Thread Together - Nipples with Flanges



Female Thread

Size (inch)	Part No.	Thread Size BSPP (inch)	Body Material	Weight (kg)	Pkg Qty
3/4	W6BF4-B-BMF	1/2	Brass	0.04	5
3/4	W6BF6-B-BMF	3/4	Brass	0.38	5
1	W8BF8-B-BMF	1	Brass	0.62	5
1 1/4	W10BF10-B-BMF	1 1/4	Brass	0.88	5
1 1/2	W12BF12-B-BMF	1 1/2	Brass	1.53	5

## W-Series - Mounting Flanges

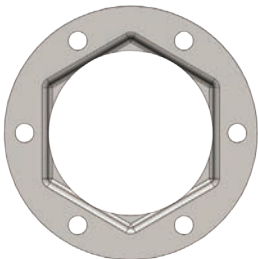

Size (inch)	Part No.	Bolt Hole Size (inch)	Body Material	Weight (kg)	Bag Qty	Pkg Qty
3/4	W6-BMF	3/4	Steel	0.03	5	50
1	W8-BMF	1/4	Steel	0.03	5	50
1 1/2	W12-BMF	3/4	Steel	0.34	5	50

- NPTF and ORB thread styles also available
- A complete range of seal options are available



Although the wingstyle couplings are able to connect and disconnect while under pressure, it is recommended that hydraulic power supply be de-energised during connection to ensure operator safety. If it is not possible to de-energize the circuit, operators must be aware of their surroundings to ensure that an attachment or tool does not put them at risk, once hydraulic power is applied during the connection process. W-Series couplings are not recommended for continuous hydraulic impulse applications at rated pressures.

FOR TECHNICAL GUIDELINES PLEASE REFER TO PAGE 201

## WS-Series High Pressure Wingstyle Interchange

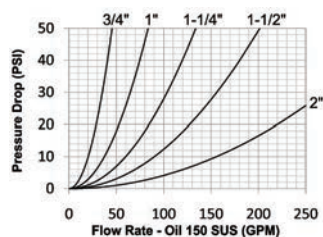

<b>Materials:</b>	<ul style="list-style-type: none"> <li>Machined components are manufactured using solid steel or 316 stainless steel bar stock</li> <li>Stainless steel retaining rings and springs maximise corrosion resistance and extend service life</li> <li>Steel componentry is plated using ROHS-compliant trivalent chrome</li> <li>Rugged high-strength steel shell-cast wing nut for threaded connect and disconnect operation</li> <li>316 stainless steel nipple connection-threads are coated to prevent galling during connection / disconnection</li> <li>1 1/4" &amp; 1 1/2" 316 stainless steel couplers have a hex-nut connection sleeve</li> </ul>
<b>Seal Components:</b>	<ul style="list-style-type: none"> <li>Nitrile (Buna-N) seals are standard providing a temperature range of <b>-40°C to 121°C (-40°F to 249°F)</b></li> <li>PTFE anti-extrusion ring protects main coupling O-ring from dynamic impulse pressure damage</li> <li>Main valve seal is housed to improve seal integrity during pressurised connection / disconnection</li> <li>Blowout prevention (BOP) couplings contain fire service grade FKM seals - coupling has been fire tested and Lloyd's certified to <b>700°C (1292°F)</b> in accordance with API 16D (Certificate #NAO 0601041/1)</li> </ul>
<b>Interchange Data:</b>	<ul style="list-style-type: none"> <li>High pressure wingstyle interchange</li> <li>Snap-Tite 75-Series, Hydraulics Inc. Series-5TV</li> </ul>

Size (inch)	Steel Coupler / Plug				316 Stainless Steel Coupler / Plug			
	Max Working		Coupled Burst		Max Working		Coupled Burst	
	PSI	bar	PSI	bar	PSI	bar	PSI	bar
3/4	5,000	345	32,800	2,200	3,000	200	20,000	1,400
1	5,000	345	25,100	1,700	3,000	200	20,000	1,400
1 1/4	5,000	345	15,000	1,000	3,000	200	15,000	1,000
1 1/2	5,000	345	19,300	1,300	3,000	200	15,000	1,000
2	5,000	345	15,000	1,000	3,000	200	15,000	1,000



Interchange Standards					Functional Parameters				
Size (inch)	US Military	US Government	International Standards	ANSI / NFPA Standards	Locking Mechanism	Air Inclusion	Fluid Loss	Vacuum inch HG	Flow (Lpm) ΔP = 30 PSI
3/4	-	-	-	-	Threaded	10cc	10cc	27.4	132
1	-	-	-	-	Threaded	23cc	15cc	27.4	246
1 1/4	-	-	-	-	Threaded	50cc	30cc	27.4	397
1 1/2	-	-	-	-	Threaded	100cc	60cc	27.4	605
2	-	-	-	-	Threaded	200cc	135cc	27.4	1022

## WS-Series High Pressure - Wingstyle Interchange Couplers



Female Thread

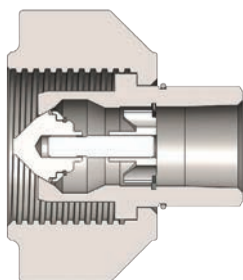

Size (inch)	Part No.	Thread Size (inch)	Body Material	Weight (kg)	Pkg Qty
3/4	6WSF6	3/4 - 14 NPTF	Steel	0.82	5
3/4	6WSF6-SS	3/4 - 14 NPTF	316 SS	0.82	5
3/4	6WSBF6	3/4 - 14 BSPP	Steel	0.82	5
3/4	6WSBF6-SS	3/4 - 14 BSPP	316 SS	0.82	5
3/4	6WSOF6	1 1/16 - 12 ORB	Steel	0.81	5
1	8WSF8	1 - 11 1/2 NPTF	Steel	1.50	5
1	8WSF8-SS	1 - 11 1/2 NPTF	316 SS	1.50	5
1	8WSBF8	1 - 11 BSPP	Steel	1.50	5
1	8WSBF8-SS	1 - 11 BSPP	316 SS	1.50	5
1	8WSOF8	1 5/16 - 12 ORB	Steel	1.48	5
1 1/4	10WSF10	1 1/4 - 11 1/2 NPTF	Steel	2.59	1
1 1/4	10WSF10-SS	1 1/4 - 11 1/2 NPTF	316 SS	2.59	1
1 1/4	10WSBF10	1 1/4 - 11 BSPP	Steel	2.59	1
1 1/4	10WSBF10-SS	1 1/4 - 11 BSPP	316 SS	2.59	1
1 1/4	10WSOF10	1 5/8 - 12 ORB	Steel	2.57	1
1 1/2	12WSF12	1 1/2 - 11 1/2 NPTF	Steel	4.04	1
1 1/2	12WSF12-SS	1 1/2 - 11 1/2 NPTF	316 SS	4.04	1
1 1/2	12WSBF12	1 1/2 - 11 BSPP	Steel	4.04	1
1 1/2	12WSBF12-SS	1 1/2 - 11 BSPP	316 SS	4.04	1
1 1/2	12WSOF12	1 7/8 - 12 ORB	Steel	4.02	1
2	16WSF16	2 - 11 1/2 NPTF	Steel	7.76	1
2	16WSF16-SS	2 - 11 1/2 NPTF	316 SS	7.76	1
2	16WSBF16	2 - 11 BSPP	Steel	7.76	1
2	16WSBF16-SS	2 - 11 BSPP	316 SS	7.76	1
2	16WSOF16	2 - 12 ORB	Steel	7.70	1

E

FOR TECHNICAL GUIDELINES PLEASE REFER TO PAGE 205



## WS-Series Blowout Prevention Safety Couplers

Size (inch)	Part No.	Thread Size (inch)	Body Material	Weight (kg)	Pkg Qty
3/4	6WSF4-BOP	1/2 - 14 NPTF	Steel	0.84	5
3/4	6WSF6-BOP	3/4 - 14 NPTF	Steel	0.82	5
3/4	6WSF6-SS-BOP	3/4 - 14 NPTF	316 SS	0.82	5
3/4	6WSBF6-BOP	3/4 - 14 BSPP	Steel	0.82	5
1	8WSF8-BOP	1 - 11 1/2 NPTF	Steel	1.50	5
1	8WSF8-SS-BOP	1 - 11 1/2 NPTF	316 SS	1.50	5
1 1/4	10WSF10-BOP	1 1/4 - 11 1/2 NPTF	Steel	2.59	1
1 1/4	10WSF10-SS-BOP	1 1/4 - 11 1/2 NPTF	316 SS	2.59	1
1 1/4	10WSBF10-BOP	1 1/4 - 11 BSPP	Steel	2.59	1
1 1/2	12WSF12-BOP	1 1/2 - 11 1/2 NPTF	Steel	4.04	1
1 1/2	12WSF12-SS-BOP	1 1/2 - 11 1/2 NPTF	316 SS	4.04	1
1 1/2	12WSBF12-BOP	1 1/2 - 11 BSPP	Steel	4.04	1
2	16WSF16-BOP	2 - 11 1/2 NPTF	Steel	7.76	1
2	16WSF16-SS-BOP	2 - 11 1/2 NPTF	316 SS	7.76	1
2	16WSBF16-BOP	2 - 11 BSPP	Steel	7.76	1



Female Thread

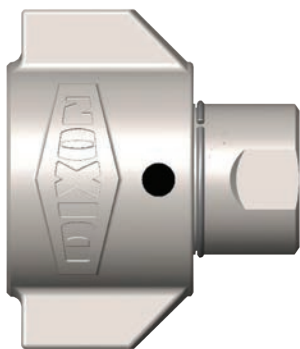
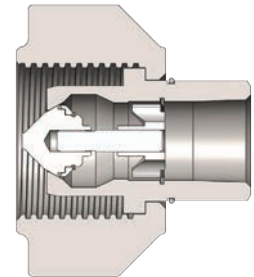

WS Coupler With View Port Example

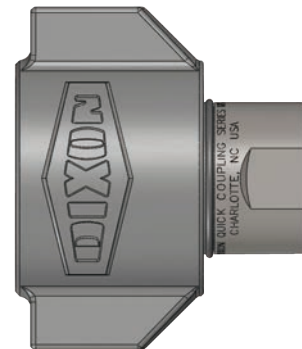

WS Coupler With Wrench Flats Example  
\* Wrench flats may result in reduced performance under pressure

## WS-BOP Series Profile

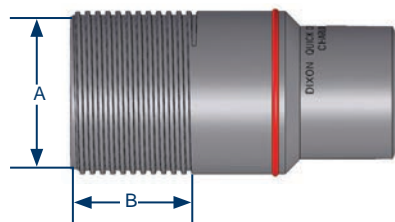

Body Size (inch)	A (mm)	B (mm)
3/4	44.45	38.10
1	57.15	46.64
1 1/4	66.68	57.15
1 1/2	82.55	66.68
2	101.60	88.90

FOR TECHNICAL GUIDELINES PLEASE REFER TO PAGE 205



## WS-Series High Pressure - Wingstyle Interchange Nipples



Female Thread

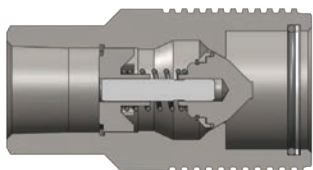

Size (inch)	Part No.	Thread Size (inch)	Body Material	Weight (kg)	Pkg Qty
3/4	WS6F4	1/2 - 14 NPTF	Steel	0.56	5
3/4	WS6F6	3/4 - 14 NPTF	Steel	0.54	5
3/4	WS6F6-SS	3/4 - 14 NPTF	316 SS	0.54	5
3/4	WS6BF6	3/4 - 14 BSPP	Steel	0.54	5
3/4	WS6BF6-SS	3/4 - 14 BSPP	316 SS	0.54	5
3/4	WS6OF6	1 1/8 - 12 ORB	Steel	0.53	5
1	WS8F8	1 - 11 1/2 NPTF	Steel	1.13	5
1	WS8F8-SS	1 - 11 1/2 NPTF	316 SS	1.13	5
1	WS8BF8	1 - 11 BSPP	Steel	1.13	5
1	WS8BF8-SS	1 - 11 BSPP	316 SS	1.13	5
1	WS8OF8	1 1/8 - 12 ORB	Steel	1.11	5
1 1/4	WS10F10	1 1/4 - 11 1/2 NPTF	Steel	1.86	1
1 1/4	WS10F10-SS	1 1/4 - 11 1/2 NPTF	316 SS	1.86	1
1 1/4	WS10BF10	1 1/4 - 11 BSPP	Steel	1.86	1
1 1/4	WS10BF10-SS	1 1/4 - 11 BSPP	316 SS	1.86	1
1 1/4	WS10OF10	1 1/8 - 12 ORB	Steel	1.89	1
1 1/2	WS12F12	1 1/2 - 11 1/2 NPTF	Steel	3.13	1
1 1/2	WS12F12-SS	1 1/2 - 11 1/2 NPTF	316 SS	3.13	1
1 1/2	WS12BF12	1 1/2 - 11 BSPP	Steel	3.13	1
1 1/2	WS12BF12-SS	1 1/2 - 11 BSPP	316 SS	3.13	1
1 1/2	WS12OF12	1 1/8 - 12 ORB	Steel	3.11	1
2	WS16F16	2 - 11 1/2 NPTF	Steel	5.67	1
2	WS16F16-SS	2 - 11 1/2 NPTF	316 SS	5.67	1
2	WS16BF16	2 - 11 BSPP	Steel	5.67	1
2	WS16BF16-SS	2 - 11 BSPP	316 SS	5.67	1
2	WS16OF16	2 - 12 ORB	Steel	5.64	1

## WS-Series Blowout Prevention Safety Nipples



Female Thread

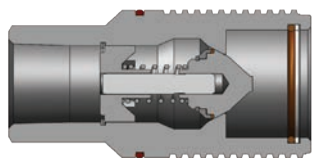

Size (inch)	Part No.	Thread Size (inch)	Body Material	Weight (kg)	Pkg Qty
3/4	WS6F4-BOP	1/2 - 14 NPTF	Steel	0.56	5
3/4	WS6F6-BOP	3/4 - 14 NPTF	Steel	0.54	5
3/4	WS6F6-SS-BOP	3/4 - 14 NPTF	316 SS	0.54	5
3/4	WS6BF6-BOP	3/4 - 14 BSPP	Steel	0.54	5
1	WS8F8-BOP	1 - 11 1/2 NPTF	Steel	1.13	5
1	WS8F8-SS-BOP	1 - 11 1/2 NPTF	316 SS	1.13	5
1 1/4	WS10F10-BOP	1 1/4 - 11 1/2 NPTF	Steel	1.80	1
1 1/4	WS10F10-SS-BOP	1 1/4 - 11 1/2 NPTF	316 SS	1.80	1
1 1/4	WS10BF10-BOP	1 1/4 - 11 BSPP	Steel	1.80	1
1 1/2	WS12F12-BOP	1 1/2 - 11 1/2 NPTF	Steel	3.13	1
1 1/2	WS12F12-SS-BOP	1 1/2 - 11 1/2 NPTF	316 SS	3.13	1
1 1/2	WS12BF12-BOP	1 1/2 - 11 BSPP	Steel	3.13	1
2	WS16F16-BOP	2 - 11 1/2 NPTF	Steel	5.67	1
2	WS16F16-SS-BOP	2 - 11 1/2 NPTF	316 SS	5.67	1
2	WS16BF16-BOP	2 - 11 BSPP	Steel	5.67	1

FOR TECHNICAL GUIDELINES PLEASE REFER TO PAGE 205

**High Pressure Wingstyle Code 62 Flange Head Coupler**

Part No.	Body Size (inch)	Port Size (inch)
6WSFH6	¾	¾
8WSFH8	1	1
10WSFH10	1¼	1¼
12WSFH12	1½	1½
16WSFH16	2	2

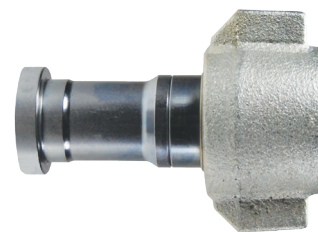
**High Pressure Wingstyle Code 62 Flange Head Plug**

Part No.	Body Size (inch)	Port Size (inch)
WS6FH6	¾	¾
WS8FH8	1	1
WS10FH10	1¼	1¼
WS12FH12	1½	1½
WS16FH16	2	2

**High Pressure Wingstyle Code 62 Flange Pad Coupler**

Part No.	Body Size (inch)	Port Size (inch)
6WSFP6	¾	¾
8WSFP8	1	1
10WSFP10	1¼	1¼
12WSFP12	1½	1½
16WSFP16	2	2

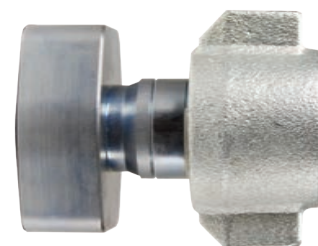

E

**High Pressure Wingstyle Code 62 Flange Pad Plug**

Part No.	Body Size (inch)	Port Size (inch)
WS6FP6	¾	¾
WS8FP8	1	1
WS10FP10	1¼	1¼
WS12FP12	1½	1½
WS16FP16	2	2

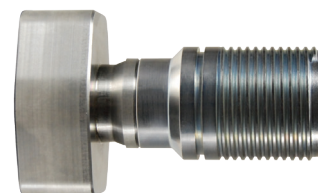

FOR TECHNICAL GUIDELINES PLEASE REFER TO PAGE 205

## WS-Series Coupler Rigid Dust Plugs



Size (inch)	Part No.	Cap Lanyard	Body Material	Weight (kg)	Pkg Qty	
					Bag	Box
¾	6WSDP-A	Steel Cable	Aluminium	0.14	5	25
1	8WSDP-A	Steel Cable	Aluminium	0.22	-	10
1¼	10WSDP-A	Steel Cable	Aluminium	0.27	-	10
1½	12WSDP-A	Steel Cable	Aluminium	0.39	-	5
2	16WSDP-A	Steel Cable	Aluminium	0.47	-	5

## WS-Series Nipple Rigid Dust Caps



Size (inch)	Part No.	Cap Lanyard	Body Material	Weight (kg)	Pkg Qty	
					Bag	Box
¾	WS6DC-A	Steel Cable	Aluminium	0.14	5	25
1	WS8DC-A	Steel Cable	Aluminium	0.22	-	10
1¼	WS10DC-A	Steel Cable	Aluminium	0.27	-	10
1½	WS12DC-A	Steel Cable	Aluminium	0.39	-	10
2	WS16DC-A	Steel Cable	Aluminium	0.47	-	5

## WS-Series High Pressure - Wingstyle Interchange Coupler Seal Kits

E



Kit Contents:		• Body / valve seals and retaining rings				
Size (inch)	Part No.	Coupler Style	Seal Material	Bag Qty	Box Qty	
¾	6WS-SKIT	All	Nitrile	25	200	
1½	12WS-SKIT	All	Nitrile	25	100	
2	16WS-SKIT	All	Nitrile	25	100	

## WS-Series BOP - Wingstyle Interchange Coupler Seal Kits



Kit Contents:		• Body / valve seals and retaining rings				
Size (inch)	Part No.	Coupler Style	Seal Material	Bag Qty	Pkg Qty	
¾	6BOP-SKIT	All	FR FKM	25	200	
1	8BOP-SKIT	All	FR FKM	25	200	
1¼	10BOP-SKIT	All	FR FKM	25	100	
1½	12BOP-SKIT	All	FR FKM	25	100	
2	16BOP-SKIT	All	FR FKM	25	100	

## WS-Series High Pressure - Wingstyle Interchange Coupler Repair Kits



Kit Contents:		• Valve assembly, O-ring, and PTFE BU				
Size (inch)	Part No.	Coupler Style	Seal Material	Bag Qty	Pkg Qty	
¾	6WS-RKIT	All	Nitrile	1	25	
1	8WS-RKIT	All	Nitrile	1	25	
1¼	10WS-RKIT	All	Nitrile	1	25	
1½	12WS-RKIT	All	Nitrile	1	25	
2	16WS-RKIT	All	Nitrile	1	25	

FOR TECHNICAL GUIDELINES PLEASE REFER TO PAGE 205

## VEP-Series Interchange

<b>Materials:</b>	<ul style="list-style-type: none"> <li>Machined components are manufactured using solid steel bar stock</li> <li>Stainless steel retaining rings and springs maximise corrosion resistance and extend service life</li> <li>Steel componentry is plated using ROHS-compliant trivalent chrome</li> </ul>
<b>Seal Components:</b>	<ul style="list-style-type: none"> <li>Nipples have nitrile-energised PTFE valve seals, with a temperature range of <b>-40°C to 121°C (-40°F to 249°F)</b></li> <li>3/8" nipples have moulded polyurethane valve seals, with a temperature range of <b>-54°C to 100°C (-65°F to 212°F)</b></li> <li>1/4" to 3/4" valve stems have moulded Acetal seals, with a temperature range of <b>-54°C to 100°C (-65°F to 212°F)</b></li> <li>1" to 2" valve stems have moulded polyurethane seals, with a temperature range of <b>-54°C to 100°C (-65°F to 212°F)</b></li> <li>Ancillary coupler and nipple seals are nitrile (buna-N), with a temperature range of <b>-40°C to 121°C (-40°F to 249°F)</b></li> <li>TPC-ET anti-extrusion ring protects main coupling valve seal from dynamic impulse pressure damage</li> </ul>
<b>Interchange Data:</b>	<ul style="list-style-type: none"> <li>Interchangeable with Stucchi VEP-P/VEP-HD Series, DNP PST4/FSI Series, Voswinkel FT Series and Parker FET-Series</li> </ul>

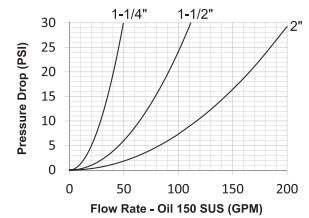
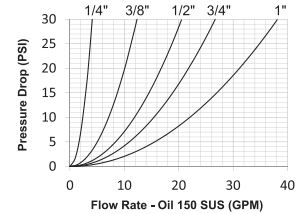

Two-stage valving to protect critical sealing components during pressurised connection and disconnection

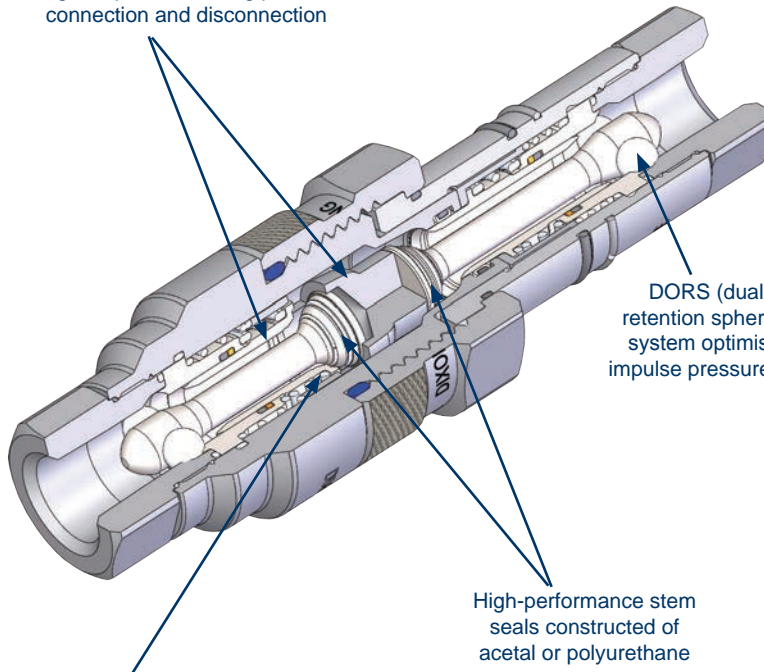

DORS (dual opposing retention spheres) retention system optimises flow and impulse pressure performance

High-performance stem seals constructed of acetal or polyurethane

Posi-Lock valve system secures valving during surge-flow conditions to prevent high-velocity damage

Size (inch)	Pressure Rating				Burst Pressure						Max Pressure Connect <sup>3</sup>		Max Pressure Disconnect <sup>3</sup>		Flow (Lpm) ΔP= 21.75PSI
	ISO Working <sup>1</sup>		Max Impulse <sup>2</sup>		Connected		Coupler		Plug		PSI	bar	PSI	bar	
	PSI	bar	PSI	bar	PSI	bar	PSI	bar	PSI	bar					
1/4	6,000	400	9,000	620	24,000	1,650	22,000	1,520	22,000	1,520	5,500	3,800	5,500	3,800	13
3/8	5,500	380	8,000	550	22,000	1,520	18,000	1,240	20,000	1,380	4,500	3,100	4,500	3,100	40
1/2	5,500	380	8,000	550	22,000	1,520	18,000	1,240	20,000	1,380	4,500	3,100	4,500	3,100	66
3/4	5,500	380	8,000	550	22,000	1,520	18,000	1,240	20,000	1,380	4,500	3,100	4,500	3,100	85
1	5,500	380	7,500	520	22,000	1,520	14,500	1,000	20,000	1,380	3,625	2,500	3,625	2,500	123
1 1/4	5,000	350	7,000	480	20,000	1,380	14,500	1,000	16,000	1,100	3,625	2,500	3,625	2,500	174
1 1/2	4,500	310	5,800	400	18,000	1,240	12,000	830	14,500	1,000	3,000	2,100	3,000	2,100	360
2	4,000	280	5,000	350	18,000	1,240	12,000	830	14,500	1,000	3,000	2,100	3,000	2,100	653

<sup>1</sup> Couplings impulse tested in accordance with ISO7241-2 for 1,000,000 cycles connected and 100,000 cycles disconnected at 133% of ISO working pressure.

<sup>2</sup> Couplings impulse tested in accordance with ISO7241-2 for 100,000 cycles connected and disconnected at maximum impulse pressure listed.

<sup>3</sup> System temperature for maximum connect/disconnect pressure must not exceed **65°C (149°F)**.



## How to Connect and Disconnect the VEP-Series Coupling

1. Prior to connecting, thoroughly clean all mating surfaces and threads on both halves, then pull the coupler sleeve forward.
2. To initiate the connection, align the coupler and plug, pushing/turning the coupler sleeve toward the plug while engaging the threads. Keep the mating halves aligned during the connection process.
3. Allow the threads to pull the coupler onto the plug. Do not push the coupler onto the plug.
4. The first phase of the connection should be threaded by hand, without the use of tools. Please note the connection sleeve may seize when dirt and debris accumulate in the threads - remove debris with a cloth, compressed air, or a brush.
5. The second phase of the connection may require a wrench if the pressure is higher than anticipated.
6. Continue to thread the coupler sleeve onto the plug until the end of the sleeve meets the plug body.
7. To disconnect, use a wrench to break the coupler sleeve free and keep the mating halves aligned during the disconnection process.

## VEP-Series Interchange Couplers

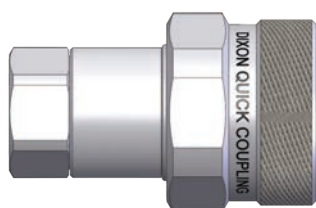

Female Thread

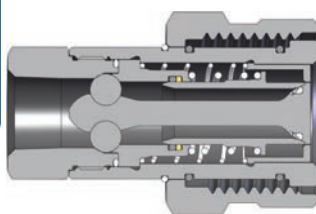

Size (inch)	Part No.	Thread Size (inch)	Hex (mm)	Weight (kg)	Pkg Qty
¼	2VEPF2	¼ - 18 NPTF	22	0.22	20
¼	2VEPBF2	¼ - 19 BSPP	22	0.22	20
¼	2VEPOF3	9/16 - 18 ORB	22	0.22	20
⅜	3VEPF3	⅜ - 18 NPTF	25	0.29	20
⅜	3VEPBF3	⅜ - 19 BSPP	25	0.29	20
⅜	3VEPOF4	¾ - 16 ORB	25	0.30	20
⅝	3VEPF4	½ - 14 NPTF	28	0.30	20
⅝	3VEPBF4	½ - 14 BSPP	28	0.30	20
½	4VEPF4	½ - 14 NPTF	30	0.62	15
½	4VEPBF4	½ - 14 BSPP	30	0.62	15
½	4VEPOF4	¾ - 16 ORB	30	0.63	15
½	4VEPOF5	7/8 - 14 ORB	32	0.65	15
½	4VEPF6	¾ - 14 NPTF	38	0.71	15
½	4VEPBF6	¾ - 14 BSPP	38	0.71	15
½	4VEPOF6	1 1/16 - 12 ORB	38	0.72	15
¾	6VEPF6	¾ - 14 NPTF	38	0.77	1
¾	6VEPBF6	¾ - 14 BSPP	38	0.77	1
¾	6VEPOF6	1 1/16 - 12 ORB	38	0.77	1
1	8VEPF8	1 - 11 1/2 NPTF	44	1.10	1
1	8VEPBF8	1 - 11 BSPP	44	1.10	1
1	8VEPOF8	1 5/16 - 12 ORB	44	1.10	1
1 ¼	10VEPF10	1 ¼ - 11 1/2 NPTF	55	1.71	1
1 ¼	10VEPBF10	1 ¼ - 11 BSPP	55	1.71	1
1 ¼	10VEPOF10	1 ¾ - 12 ORB	55	1.71	1
1 ½	12VEPF12	1 ½ - 11 1/2 NPTF	63	4.13	1
1 ½	12VEPBF12	1 ½ - 11 BSPP	63	4.13	1
1 ½	12VEPOF12	1 ¾ - 12 ORB	63	4.13	1
2	16VEPF16	2 - 11 1/2 NPTF	89	15.22	1
2	16VEPBF16	2 - 11 BSPP	89	15.22	1
2	16VEPOF16	2 - 12 ORB	89	15.22	1

## VEP-Series Profile

Body Size (inch)	A (mm)	B (mm)
¼	15.88	12.70
⅜	19.84	17.46
½	24.61	19.05
¾	26.99	19.05
1	30.16	23.81
1 ¼	36.51	25.40
1 ½	57.15	31.75
2	87.31	61.91

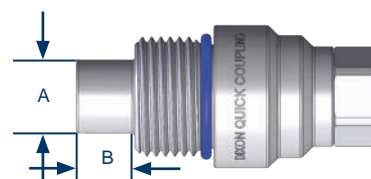

FOR TECHNICAL GUIDELINES PLEASE REFER TO PAGE 211

### VEP-Series Interchange Nipples

Size (inch)	Part No.	Thread Size (inch)	Hex (mm)	Weight (kg)	Pkg Qty
¼	VEP2F2	¼ - 18 NPTF	22	0.24	20
¼	VEP2BF2	¼ - 19 BSPP	22	0.24	20
¼	VEP2OF3	9/16 - 18 ORB	22	0.24	20
¾	VEP3F3	¾ - 18 NPTF	25	0.34	20
¾	VEP3BF3	¾ - 19 BSPP	25	0.34	20
¾	VEP3OF4	¾ - 16 ORB	25	0.35	20
¾	VEP3F4	½ - 14 NPTF	28	0.35	20
¾	VEP3BF4	½ - 14 BSPP	28	0.35	20
½	VEP4F4	½ - 14 NPTF	30	0.59	10
½	VEP4BF4	½ - 14 BSPP	30	0.59	10
½	VEP4OF4	¾ - 16 ORB	30	0.59	10
½	VEP4OF5	7/8 - 14 ORB	32	0.61	10
½	VEP4F6	¾ - 14 NPTF	38	0.67	10
½	VEP4BF6	¾ - 14 BSPP	38	0.67	10
½	VEP4OF6	1 1/16 - 12 ORB	38	0.68	10
¾	VEP6F6	¾ - 14 NPTF	38	0.83	1
¾	VEP6BF6	¾ - 14 BSPP	38	0.83	1
¾	VEP6OF6	1 1/16 - 12 ORB	38	0.83	1
1	VEP8F8	1 - 11 1/2 NPTF	44	1.20	1
1	VEP8BF8	1 - 11 BSPP	44	1.20	1
1	VEP8OF8	1 5/16 - 12 ORB	44	1.20	1
1 ¼	VEP10F10	1 ¼ - 11 1/2 NPTF	55	1.44	1
1 ¼	VEP10BF10	1 ¼ - 11 BSPP	55	1.44	1
1 ¼	VEP10OF10	1 9/8 - 12 ORB	55	1.44	1
1 ½	VEP12F12	1 ½ - 11 1/2 NPTF	63	4.09	1
1 ½	VEP12BF12	1 ½ - 11 BSPP	63	4.09	1
1 ½	VEP12OF12	1 7/8 - 12 ORB	63	4.09	1
2	VEP16F16	2 - 11 1/2 NPTF	89	12.86	1
2	VEP16BF16	2 - 11 BSPP	89	12.86	1
2	VEP16OF16	2 - 12 ORB	89	12.86	1



Female Thread

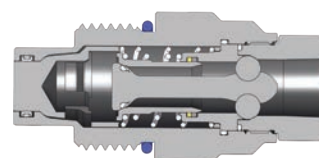

### VEP-Series Rigid Dust Plugs

Size (inch)	Part No.	Weight (kg)	Pkg Qty	
			Bag	Box
¼	2VEPDP-A	0.03	5	50
¾	3VEPDP-A	0.06	5	50
½	4VEPDP-A	0.06	5	25
¾	6VEPDP-A	0.09	5	25
1	8VEPDP-A	0.14	-	10
1 ¼	10VEPDP-A	0.17	-	10
1 ½	12VEPDP-A	0.45	-	5
2	16VEPDP-A	1.72	-	1

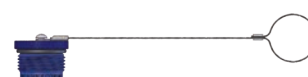

### VEP-Series Rigid Dust Caps

Size (inch)	Part No.	Weight (kg)	Pkg Qty	
			Bag	Box
¼	VEP2DC-A	0.03	5	50
¾	VEP3DC-A	0.06	5	50
½	VEP4DC-A	0.07	5	50
¾	VEP6DC-A	0.11	5	25
1	VEP8DC-A	0.17	-	10
1 ¼	VEP10DC-A	0.28	-	10
1 ½	VEP12DC-A	0.68	-	5
2	VEP16DC-A	1.81	-	1



Note: VEP Series dust caps and plugs are aluminium with a stainless steel bead chain.

FOR TECHNICAL GUIDELINES PLEASE REFER TO PAGE 211



+44 (0)1772 323529  
europe.dixonvalve.com  
sale@technobearing.ru

TECHNOBEARING.RU

DGEL2020  
8 (800) 700-72-07

# Hydraulic & Pneumatic

## VEP-BOP Series Hydraulic Couplings

<b>Materials:</b>	<ul style="list-style-type: none"> <li>Machined components are manufactured using solid steel bar stock</li> <li>Stainless steel retaining rings and springs maximise corrosion resistance and extend service life</li> <li>Steel componentry is plated using ROHS-compliant zinc nickel</li> <li>Red powder-coated components and external O-rings for easy blowout prevention (BOP) service identification</li> </ul>
<b>Seal Components:</b>	<ul style="list-style-type: none"> <li>BOP coupling critical seals are made of FKM for severe service applications</li> <li>PTFE anti-extrusion ring protects main coupling valve seal from dynamic impulse pressure damage</li> </ul>
<b>Interchange Data:</b>	<ul style="list-style-type: none"> <li>Stucchi VEP/VEP-HD Series, DNP FSI-BOP Series</li> </ul>

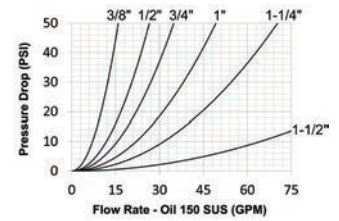

- BOP couplings have been fire tested and Lloyd's certified to **700°C (1292°F)** in accordance with API 16D. Certificate available upon request
- Use VEP dust caps and dust plugs found on page 213

Lloyd's Test Pressure	
Size (inch)	PSI
3/8	5,000
1/2	5,000
3/4	5,000
1"	5,000
1 1/4	5,000
1 1/2	5,000

E

Rated Pressure Chart VEP-BOP Series Interchange																
Size (inch)	Pressure Rating				Burst Pressure						Max. Pressure Connect		Max. Pressure Disconnect		Rated Flow $\Delta P=21.75\text{PSI}$	
	ISO Working		Max. Impulse		Connected		Coupler		Plug		PSI	MPa	PSI	MPa	PSI	MPa
	PSI	MPa	PSI	MPa	PSI	MPa	PSI	MPa	PSI	MPa						
3/8	5,500	38	8,000	55	22,000	152	18,000	124	20,000	138	4,500	31	4,500	31	10.5	40
1/2	5,500	38	8,000	55	22,000	152	18,000	124	20,000	138	4,500	31	4,500	31	17.5	66
3/4	5,500	38	8,000	55	22,000	152	18,000	124	20,000	138	4,500	31	4,500	31	22.7	85
1	5,500	38	7,500	52	22,000	152	14,500	100	20,000	138	3,625	25	3,625	25	32.5	123
1 1/4	5,000	35	7,000	48	20,000	138	14,500	100	16,000	110	3,625	25	3,625	25	46.4	174
1 1/2	5,000	31	5,800	40	18,000	124	12,000	83	14,500	100	3,000	21	3,000	21	95.0	360

- Contact Dixon™ for availability of other end configurations

## VEP-BOP Series Profile

Body Size (inch)	A (mm)	B (mm)
3/8	19.84	17.46
1/2	24.61	19.05
3/4	26.99	19.05
1	30.16	23.81
1 1/4	36.51	25.40
1 1/2	57.15	31.75

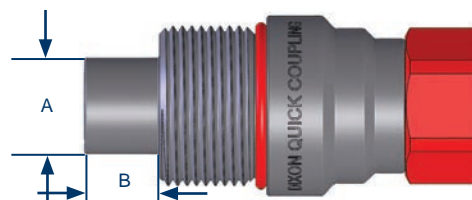



## VEP-BOP Series Hydraulic Couplers

VEP-BOP Series Blowout Prevention Safety Coupler (Female Threads)											
Size (inch)	Part Detail			Length		Maximum OD		Hex (mm)	Weight (kg)	Package Qty	
	Part No.	Threads	Material	inch	mm	inch	mm			Bag	Box
3/8	3VEPF3-BOP	3/8" - 18 NPTF	Steel	2.55	64.8	1.62	41.1	25	0.28	-	20
1/2	4VEPF4-BOP	1/2" - 14 NPTF	Steel	3.08	78.2	1.98	50.3	30	0.62	-	15
3/4	6VEPF6-BOP	3/4" - 14 NPTF	Steel	3.37	85.6	2.19	55.6	38	0.77	-	1
1	8VEPF8-BOP	1" - 11 1/2 NPTF	Steel	3.89	98.8	2.46	62.5	44	1.11	-	1
1 1/4	10VEPF10-BOP	1 1/4" - 11 1/2 NPTF	Steel	4.40	111.8	2.70	68.6	55	1.71	-	1
1 1/2	12VEPF12-BOP	1 1/2" - 11 1/2 NPTF	Steel	5.28	134.1	3.74	95.0	63	4.13	-	1

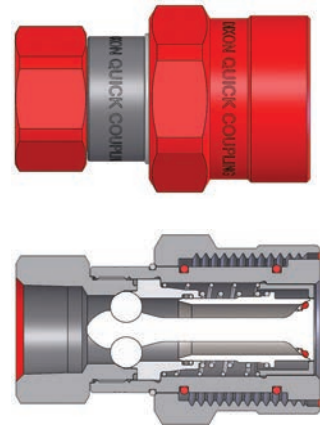

## VEP-BOP Series Hydraulic Nipples

VEP-BOP Series Blowout Prevention Safety Nipple (Female Threads)											
Size (inch)	Part Detail			Length		Maximum OD		Hex (mm)	Weight (kg)	Package Qty	
	Part No.	Threads	Material	inch	mm	inch	mm			Bag	Box
3/8	VEP3F3-BOP	3/8" - 18 NPTF	Steel	3.28	83.3	1.48	37.6	25	0.35	-	20
1/2	VEP4F4-BOP	1/2" - 14 NPTF	Steel	3.87	98.3	1.86	47.2	30	0.59	-	10
3/4	VEP6F6-BOP	3/4" - 14 NPTF	Steel	4.12	104.6	1.98	50.3	38	0.84	-	1
1	VEP8F8-BOP	1" - 11 1/2 NPTF	Steel	4.95	125.7	2.20	55.9	44	1.20	-	1
1 1/4	VEP10F10-BOP	1 1/4" - 11 1/2 NPTF	Steel	5.43	137.9	2.73	69.3	55	1.44	-	1
1 1/2	VEP12F12-BOP	1 1/2" - 11 1/2 NPTF	Steel	6.63	164.4	3.74	95.0	63	4.10	-	1

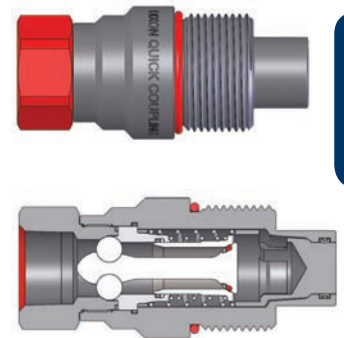

FOR TECHNICAL GUIDELINES PLEASE REFER TO PAGE 214

# Hydraulic & Pneumatic

## HT-Series ISO16028 Flushface Interchange

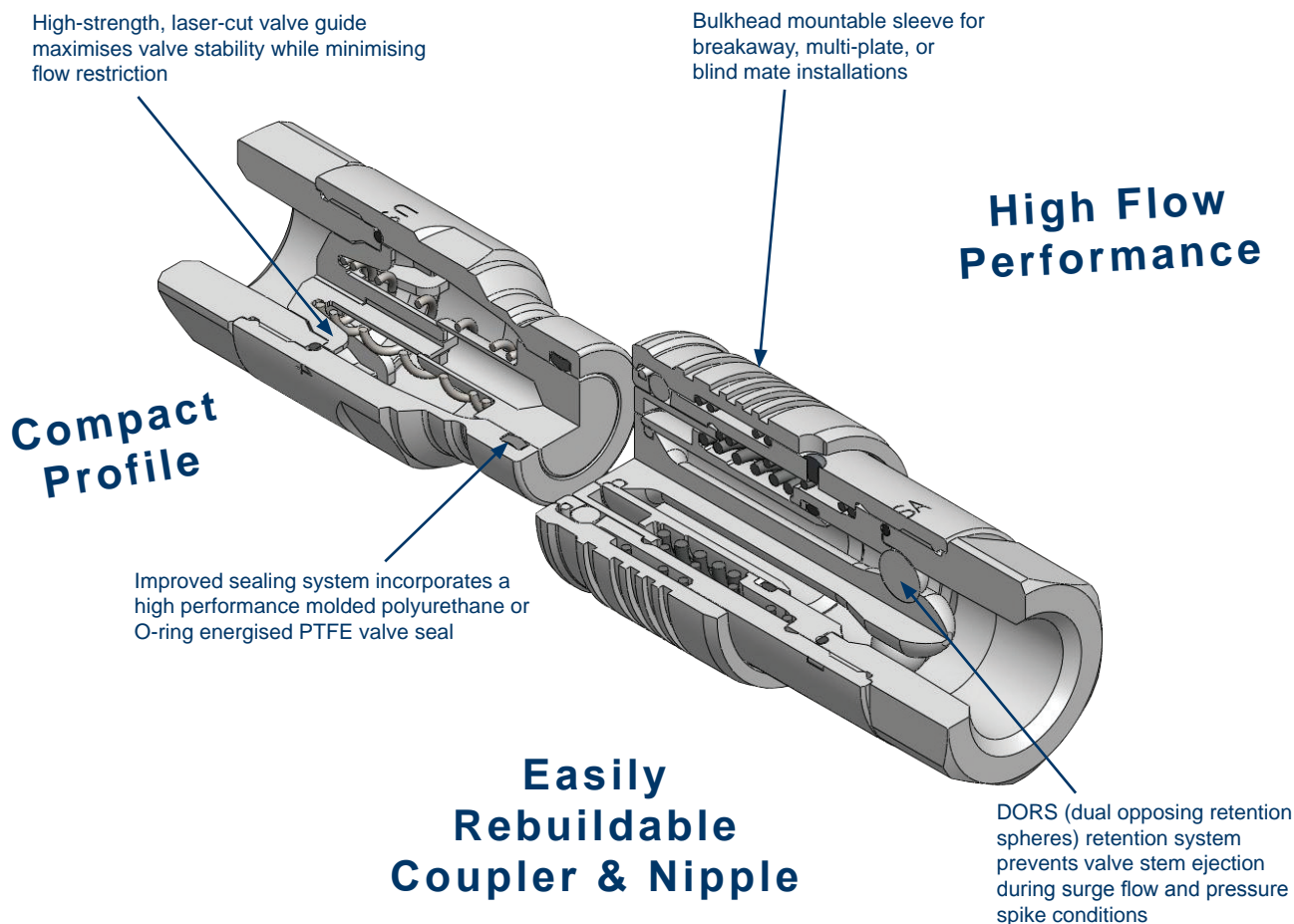

E

### Use the Profile Layover to Select Proper Size

Body Size (inch)	A (mm)	B (mm)
1/4	15.88	6.35
3/8	19.05	4.76
1/2	23.81	9.53
5/8	26.99	11.11
3/4	30.16	11.11
1	35.72	11.11

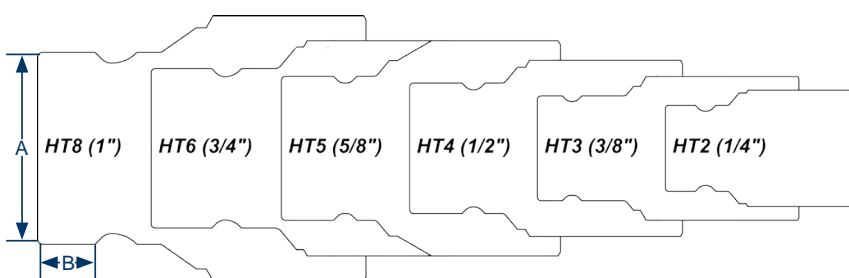

FOR TECHNICAL GUIDELINES PLEASE REFER TO PAGE 217

# Hydraulic & Pneumatic

## HT-Series ISO16028 Flushface Interchange

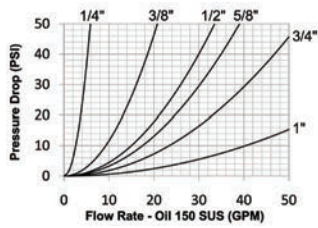

<b>Materials:</b>	<ul style="list-style-type: none"> <li>Machined components are manufactured using solid steel or 316 stainless steel bar stock</li> <li>Stainless steel balls, retaining rings, and springs maximise corrosion resistance and extend service life</li> <li>Steel componentry is plated using ROHS-compliant trivalent chrome</li> <li>Steel coupler sleeves are hardened to resist deformation and maximise service life</li> <li>Steel nipples are hardened to provide resistance to brinelling during impulse service</li> </ul>
<b>Seal Components:</b>	<ul style="list-style-type: none"> <li>3/8", 1/2", and 3/4" nipples have moulded polyurethane valve seals, with a temperature range of <b>-54°C to 100°C (-65°F to 212°F)</b></li> <li>1/4", 5/8", and 1" to 2" nipples have nitrile-energised PTFE valve seals, with a temperature range of <b>-40°C to 121°C (-40°F to 249°F)</b></li> <li>Couplers have a polyurethane valve stem O-ring, with a temperature range of <b>-54°C to 100°C (-65°F to 212°F)</b></li> <li>Ancillary coupler and nipple seals are nitrile (buna-N), with a temperature range of <b>-40°C to 121°C (-40°F to 249°F)</b></li> <li>PTFE or TPC-ET anti-extrusion ring protects main coupling valve seal from dynamic impulse pressure damage</li> </ul>
<b>Interchange Data:</b>	<ul style="list-style-type: none"> <li>Interchangeable to ISO16028</li> <li>Parker FEM-Series, Snap-Tite 74-Series, Hansen FF, Aeroquip/Eaton FD89, Stucchi FIRG/Series A, Faster FFN/FFI/2FFN/2FFI, Safeway FF49-Series, Ryco R110 Series</li> </ul>
<b>Standards:</b>	<ul style="list-style-type: none"> <li>HT-Series flushface couplings are fully compliant with the parameters outlined in ISO16028</li> </ul>

Size (inch)	Steel Coupler / Plug Coupled				316SS Coupler / Plug Coupled				Steel Coupler Uncoupled				Steel Plug Uncoupled			
	Working Pressure		Burst Pressure		Working Pressure		Burst Pressure		Working Pressure		Burst Pressure		Working Pressure		Burst Pressure	
	PSI	Bar	PSI	Bar	PSI	Bar	PSI	Bar	PSI	Bar	PSI	Bar	PSI	Bar	PSI	Bar
1/4	5,000	345	20,000	1,379	-	-	-	-	5,000	345	20,000	1,379	5,000	345	20,000	1,379
3/8	5,000	345	20,000	1,379	3,500	241	17,500	1,207	5,000	345	20,000	1,379	5,000	345	20,000	1,379
1/2	5,000	345	20,000	1,379	3,400	234	17,000	1,172	5,000	345	20,000	1,379	5,000	345	20,000	1,379
5/8	5,000	345	20,000	1,379	2,920	201	14,600	1,007	5,000	345	20,000	1,379	5,000	345	20,000	1,379
3/4	5,000	345	20,000	1,379	2,920	201	14,600	1,007	5,000	345	20,000	1,379	5,000	345	20,000	1,379
1	5,000	345	20,000	1,379	2,920	201	14,600	1,007	5,000	345	20,000	1,379	5,000	345	20,000	1,379
1 1/2	3,000	207	12,000	828	-	-	-	-	3,000	207	12,000	828	3,000	207	12,000	828
2	3,000	207	12,000	828	-	-	-	-	3,000	207	12,000	828	3,000	207	12,000	828

Interchange Standards					Functional Parameters					
Size (inch)	US Military	US Government	International Standards	ANSI / NFPA Standards	Locking Ball Qty	Air Inclusion	Fluid Loss	Vacuum inch HG	Flow (Lpm) ΔP = 15 PSI	
1/4	-	-	ISO16028	-	12	n/a	0.010cc	N/R	3.2 GPM	
3/8	-	-	ISO16028	T3.20.15	12	n/a	0.010cc	N/R	11 GPM	
1/2	-	*	ISO16028	*	12	n/a	0.010cc	N/R	18 GPM	
5/8	-	*	ISO16028	*	12	n/a	0.020cc	N/R	21 GPM	
3/4	-	*	ISO16028	*	12	n/a	0.030cc	N/R	28 GPM	
1	-	*	ISO16028	*	12	n/a	0.030cc	N/R	50 GPM	
1 1/2	-	-	-	-	18	n/a	0.050cc	N/R	140 GPM	
2	-	-	-	-	20	n/a	0.070cc	N/R	225 GPM	

\* These particular sizes are not outlined within the documented standard category

HT-Series Interchange						
Size (inch)	Parker	Snap Tite	Faster	Holmbury	Stucchi	Eaton / Aeroquip
3/8	FF Series	74 Series	FN/2FFN/2FFI	Series A	FIRG Series A	FD89
1/2	FE Series	74 Series	FFI/2FFI/3FFI	Series A	FIRG Series A	FD89
5/8	FE Series	74 Series	FFI/2FFI/3FFI	Series A	FIRG Series A	FD89
3/4	FE Series	74 Series	FFI/2FFI/3FFI	Series A	FIRG Series A	FD89
1	-	74 Series	FFI/2FFI/3FFI	Series A	FIRG Series A	FD89
1 1/2	-	74 Series	FFI/2FFI/3FFI	Series A	FIRG Series A	FD89
2	-	74 Series	FFI/2FFI/3FFI	Series A	FIRG Series A	FD89

- NPTF and ORB thread styles also available
- A complete range of seal options are available



## HT-Series Coupler Dust Plugs



Size (inch)	Part No.	Body Material	Weight (kg)	Pkg Qty	
				Bag	Box
1/4	2HTDP	Nitrile	0.022	5	5
1/2	4HTDP	Nitrile	0.027	5	5
5/8	5HTDP	Nitrile	0.031	5	5
3/4	6HTDP	Nitrile	0.031	5	5
1	8HTDP	Nitrile	0.068	5	5

NOTE: Fits Dixon™ couplers only

## HT-Series Nipple Dust Caps



Size (inch)	Part No.	Body Material	Weight (kg)	Pkg Qty	
				Bag	Box
1/4	HT2DC	Nitrile	0.018	5	5
3/8	HT3DC	Nitrile	0.018	5	5
1/2	HT4DC	Nitrile	0.018	5	5
5/8	HT5DC	Nitrile	0.027	5	5
3/4	HT6DC	Nitrile	0.027	5	5
1	HT8DC	Nitrile	0.045	5	5

NOTE: Fits all ISO16028 nipples

## HT-Series Couplers



Female Thread

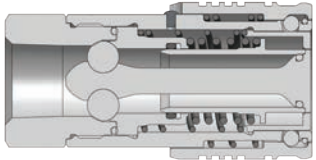

Size (inch)	Part No.	Thread Size (inch)	Body Material	Weight (kg)	Pkg Qty	
					Bag	Box
1/4	2HTF2	1/4 - 18 NPTF	Steel	0.10	-	25
1/4	2HTBF2	1/4 - 19 BSPP	Steel	0.10	-	25
3/8	3HTF3	3/8 - 18 NPTF	Steel	0.20	-	25
3/8	3HTF3-SS	3/8 - 18 NPTF	316 SS	0.20	-	25
3/8	3HTBF3	3/8 - 19 BSPP	Steel	0.20	-	25
3/8	3HTBF3-SS	3/8 - 19 BSPP	316 SS	0.20	-	25
3/8	3HTOF3	3/8 - 18 ORB	Steel	0.22	-	25
3/8	3HTF4	1/2 - 14 NPTF	Steel	0.22	-	25
3/8	3HTF4-SS	1/2 - 14 NPTF	316 SS	0.22	-	25
3/8	3HTBF4	1/2 - 14 BSPP	Steel	0.22	-	25
3/8	3HTBF4-SS	1/2 - 14 BSPP	316 SS	0.22	-	25
3/8	3HTOF4	3/4 - 16 ORB	Steel	0.24	-	25
1/2	4HTF4	1/2 - 14 NPTF	Steel	0.39	-	20
1/2	4HTF4-SS	1/2 - 14 NPTF	316 SS	0.39	-	20
1/2	4HTBF4	1/2 - 14 BSPP	Steel	0.39	-	20
1/2	4HTBF4-SS	1/2 - 14 BSPP	316 SS	0.39	-	20
1/2	4HTOF4	3/4 - 16 ORB	Steel	0.39	-	20
1/2	4HTOF5	7/8 - 14 ORB	Steel	0.41	-	20
1/2	4HTF6	3/4 - 14 NPTF	Steel	0.44	-	20
1/2	4HTF6-SS	3/4 - 14 NPTF	316 SS	0.44	-	20
1/2	4HTBF6	3/4 - 14 BSPP	Steel	0.44	-	20
1/2	4HTBF6-SS	3/4 - 14 BSPP	316 SS	0.44	-	20
1/2	4HTOF6	1 1/16 - 12 ORB	Steel	0.43	-	20
5/8	5HTOF5	7/8 - 14 ORB	Steel	0.72	-	10
5/8	5HTF6	3/4 - 14 NPTF	Steel	0.68	-	10
5/8	5HTF6-SS	3/4 - 14 NPTF	316 SS	0.68	-	10
5/8	5HTBF6	3/4 - 14 BSPP	Steel	0.68	-	10
5/8	5HTBF6-SS	3/4 - 14 BSPP	316 SS	0.68	-	10
5/8	5HTOF6	1 1/16 - 12 ORB	Steel	0.68	-	10
3/4	6HTOF5	7/8 - 14 ORB	Steel	0.82	-	10
3/4	6HTF6	3/4 - 14 NPTF	Steel	0.82	-	10
3/4	6HTF6-SS	3/4 - 14 NPTF	316 SS	0.82	-	10
3/4	6HTBF6	3/4 - 14 BSPP	Steel	0.83	-	10
3/4	6HTBF6-SS	3/4 - 14 BSPP	316 SS	0.83	-	10
3/4	6HTOF6	1 1/16 - 12 ORB	Steel	0.87	-	10
3/4	6HTF8	1 - 11 1/2 NPTF	Steel	0.93	-	10
3/4	6HTF8-SS	1 - 11 1/2 NPTF	316 SS	0.93	-	10
3/4	6HTBF8	1 - 11 BSPP	Steel	0.93	-	10
3/4	6HTBF8-SS	1 - 11 BSPP	316 SS	0.93	-	10
3/4	6HTOF8	1 1/16 - 12 ORB	Steel	0.98	-	10
1	8HTF8	1 - 11 1/2 NPTF	Steel	1.21	-	10
1	8HTF8-SS	1 - 11 1/2 NPTF	316 SS	1.21	-	10
1	8HTBF8	1 - 11 BSPP	Steel	1.21	-	10
1	8HTBF8-SS	1 - 11 BSPP	316 SS	1.21	-	10
1	8HTOF8	1 1/16 - 12 ORB	Steel	1.21	-	10
1	8HTF10	1 1/4 - 11 1/2 NPTF	Steel	1.25	-	10
1	8HTF10-SS	1 1/4 - 11 1/2 NPTF	316 SS	1.25	-	10
1	8HTBF10	1 1/4 - 11 BSPP	Steel	1.25	-	10
1	8HTBF10-SS	1 1/4 - 11 BSPP	316 SS	1.25	-	10
1	8HTOF10	1 1/2 - 12 ORB	Steel	1.29	-	10

- NPTF and ORB thread styles also available
- A complete range of seal options are available

FOR TECHNICAL GUIDELINES PLEASE REFER TO PAGE 217



### HT-Series Nipples

Size (inch)	Part No.	Thread Size (inch)	Body Material	Weight (kg)	Pkg Qty	
					Bag	Box
¼	HT2F2	¼ - 18 NPTF	Steel	0.07	-	25
¼	HT2BF2	¼ - 19 BSPP	Steel	0.07	-	25
¾	HT3F3	¾ - 18 NPTF	Steel	0.12	-	25
¾	HT3F3-SS	¾ - 18 NPTF	316 SS	0.12	-	25
¾	HT3BF3	¾ - 19 BSPP	Steel	0.12	-	25
¾	HT3BF3-SS	¾ - 19 BSPP	316 SS	0.12	-	25
¾	HT3OF3	¾ - 18 ORB	Steel	0.15	-	25
¾	HT3F4	½ - 14 NPTF	Steel	0.14	-	25
¾	HT3F4-SS	½ - 14 NPTF	316 SS	0.14	-	25
¾	HT3BF4	½ - 14 BSPP	Steel	0.14	-	25
¾	HT3BF4-SS	½ - 14 BSPP	316 SS	0.14	-	25
¾	HT3OF4	¾ - 16 ORB	Steel	0.16	-	25
½	HT4F4-SS	½ - 14 NPTF	316 SS	0.19	-	20
½	HT4BF4	½ - 14 BSPP	Steel	0.19	-	20
½	HT4BF4-SS	½ - 14 BSPP	316 SS	0.19	-	20
½	HT4OF4	¾ - 16 ORB	Steel	0.18	-	20
½	HT4OF5	¾ - 14 ORB	Steel	0.19	-	20
½	HT4F6	¾ - 14 NPTF	Steel	0.24	-	20
½	HT4F6-SS	¾ - 14 NPTF	316 SS	0.24	-	20
½	HT4BF6	¾ - 14 BSPP	Steel	0.24	-	20
½	HT4BF6-SS	¾ - 14 BSPP	316 SS	0.24	-	20
½	HT4OF6	1 ¼ - 12 ORB	Steel	0.26	-	20
⅝	HT5OF5	¾ - 14 ORB	Steel	0.41	-	10
⅝	HT5F6	¾ - 14 NPTF	Steel	0.43	-	10
⅝	HT5F6-SS	¾ - 14 NPTF	316 SS	0.43	-	10
⅝	HT5BF6	¾ - 14 BSPP	Steel	0.43	-	10
⅝	HT5BF6-SS	¾ - 14 BSPP	316 SS	0.43	-	10
⅝	HT5OF6	1 ¼ - 12 ORB	Steel	0.46	-	10
¾	HT6OF5	¾ - 14 ORB	Steel	0.45	-	10
¾	HT6F6	¾ - 14 NPTF	Steel	0.45	-	10
¾	HT6F6-SS	¾ - 14 NPTF	316 SS	0.45	-	10
¾	HT6BF6	¾ - 14 BSPP	Steel	0.45	-	10
¾	HT6BF6-SS	¾ - 14 BSPP	316 SS	0.45	-	10
¾	HT6OF6	1 ¼ - 12 ORB	Steel	0.46	-	10
¾	HT6F8	1 - 11 ½ NPTF	Steel	0.52	-	10
¾	HT6F8-SS	1 - 11 ½ NPTF	316 SS	0.52	-	10
¾	HT6BF8	1 - 11 BSPP	Steel	0.52	-	10
¾	HT6BF8-SS	1 - 11 BSPP	316 SS	0.52	-	10
¾	HT6OF8	1 ½ - 12 ORB	Steel	0.51	-	10
1	HT8F8	1 - 11 ½ NPTF	Steel	0.77	-	10
1	HT8F8-SS	1 - 11 ½ NPTF	316 SS	0.77	-	10
1	HT8BF8	1 - 11 BSPP	Steel	0.77	-	10
1	HT8BF8-SS	1 - 11 BSPP	316 SS	0.77	-	10
1	HT8OF8	1 ½ - 12 ORB	Steel	0.75	-	10
1	HT8F10	1 ¼ - 11 ½ NPTF	Steel	0.83	-	10
1	HT8F10-SS	1 ¼ - 11 ½ NPTF	316 SS	0.83	-	10
1	HT8BF10	1 ¼ - 11 BSPP	Steel	0.83	-	10
1	HT8BF10-SS	1 ¼ - 11 BSPP	316 SS	0.83	-	10
1	HT8OF10	1 ½ - 12 ORB	Steel	0.87	-	10



Female Thread

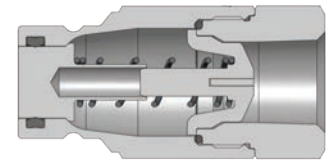

- NPTF and ORB thread styles also available
- A complete range of seal options are available

FOR TECHNICAL GUIDELINES PLEASE REFER TO PAGE 217



+44 (0)1772 323529  
 europe.dixonvalve.com  
 sale@technobearing.ru

TECHNOBEARING.RU

DGEL2020  
 8 (800) 700-72-07

# Hydraulic & Pneumatic

## HT-Series Couplers



Male Thread

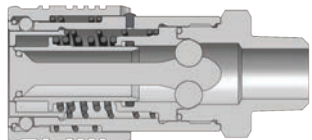

Size (inch)	Part No.	Thread Size (inch)	Body Material	Weight (kg)	Pkg Qty	
					Bag	Box
3/8	3HTM3	3/8 - 18 NPTF	Steel	0.21	5	25
3/8	3HTM4	1/2 - 14 NPTF	Steel	0.22	5	25
1/2	4HTM4	1/2 - 14 NPTF	Steel	0.44	-	20

## HT-Series Nipples



Male Thread

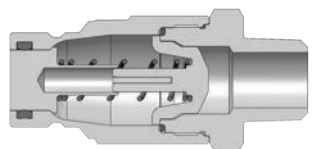

Size (inch)	Part No.	Thread Size (inch)	Body Material	Weight (kg)	Pkg Qty	
					Bag	Box
3/8	HT3M3	3/8 - 18 NPTF	Steel	0.21	5	25
3/8	HT3M4	1/2 - 14 NPTF	Steel	0.22	5	25
1/2	HT4M4	1/2 - 14 NPTF	Steel	0.44	-	20

## HT-Series Couplers - ORB



Male ORB Thread

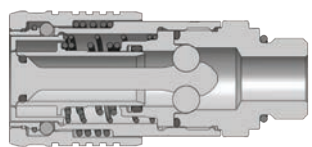

Size (inch)	Part No.	Thread Size (inch)	Body Material	Weight (kg)	Pkg Qty	
					Bag	Box
3/8	3HTOM3	3/8 - 18 ORB	Steel	0.21	5	25
3/8	3HTOM4	1/2 - 16 ORB	Steel	0.21	5	25

## HT-Series Nipples - ORB



Male ORB Thread

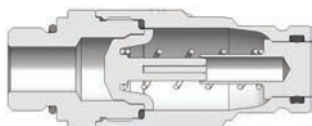

Size (inch)	Part No.	Thread Size (inch)	Body Material	Weight (kg)	Pkg Qty	
					Bag	Box
3/8	HT3OM3	3/8 - 18 ORB	Steel	0.21	5	25
3/8	HT3OM4	1/2 - 16 ORB	Steel	0.21	5	25

- NPTF and ORB thread styles also available
- A complete range of seal options are available

FOR TECHNICAL GUIDELINES PLEASE REFER TO PAGE 217



## HT-Series Couplers - Bulkhead

Size (inch)	Part No.	Thread Size (inch)	Body Material	Weight (kg)	Pkg Qty	
					Bag	Box
½	4HTJB5	¾ - 14 JIC BH	Steel	0.49	-	20
½	4HTRB5	1 - 14 ORFS BH	Steel	0.50	-	20
½	4HTJB6	1½ - 12 JIC BH	Steel	0.55	-	20



Male Bulkhead Thread

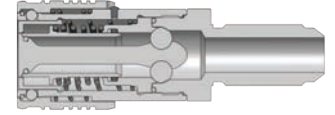

## HT-Series Nipples - Bulkhead

Size (inch)	Part No.	Thread Size (inch)	Body Material	Weight (kg)	Pkg Qty	
					Bag	Box
½	HT4JB5	¾ - 14 JIC BH	Steel	0.19	-	20
½	HT4RB5	1 - 14 ORFS BH	Steel	0.22	-	20
½	HT4JB6	1½ - 12 JIC BH	Steel	0.24	-	20



Male Bulkhead Thread

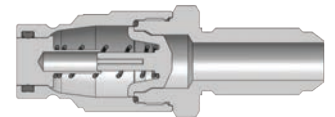

## HT-Series Couplers

Size (inch)	Part No.	Thread Size (inch)	Body Material	Weight (kg)	Pkg Qty	
					Bag	Box
1½	12HTF12	1½" - 11½ NPT	Steel	4.1	-	1
1½	12HTBF12	1½ - 11 BSPP	Steel	4.1	-	1
1½	12HTOF12	1¾" - 12 ORB	Steel	4.1	-	1
2	16HTF16	2" - 11½ NPTF	Steel	6.26	-	1
2	16HTBF16	2" - 11 BSPP	Steel	6.26	-	1
2	16HTOF16	2½" - 12 ORB	Steel	6.26	-	1

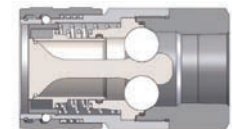

Female Thread



## HT-Series Nipples

Size (inch)	Part No.	Thread Size (inch)	Body Material	Weight (kg)	Pkg Qty	
					Bag	Box
1½	HT12F12	1½" - 11½ NPT	Steel	1.6	-	1
1½	HT12BF12	1½ - 11 BSPP	Steel	1.6	-	1
1½	HT12OF12	1¾" - 12 ORB	Steel	1.6	-	1
2	HT16F16	2" - 11½ NPTF	Steel	2.31	-	1
2	HT16BF16	2" - 11 BSPP	Steel	2.31	-	1
2	HT16OF16	2½" - 12 ORB	Steel	2.31	-	1

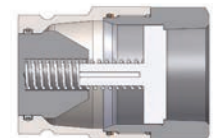

Female Thread



- NPTF and ORB thread styles also available
- A complete range of seal options are available

FOR TECHNICAL GUIDELINES PLEASE REFER TO PAGE 217

# Hydraulic & Pneumatic

## HT-Series Flushface Interchange Seal Kits

HT-Series Coupler Seal Kits						
Size (inch)	Part No.	Coupler Style	Seal Material	Seal Kits Contents	Pkg Qty	
					Bag	Box
¼	2HT-SKIT	All	Nitrile	Stem / Adaptor / Gland O-ring, Gland BU	25	200
¾	5HT-SKIT	All	Nitrile	Stem / Adaptor / Gland O-ring, Gland BU	25	200

HT-Series Nipple Seal Kits						
Size (inch)	Part No.	Coupler Style	Seal Material	Seal Kits Contents	Pkg Qty	
					Bag	Box
¼	HT2-SKIT-V2	All	Nitrile	Main Valve Seal and Adaptor O-ring	25	200
¾	HT3-SKIT-V2	All	Nitrile	Main Valve Seal and Adaptor O-ring	25	200
½	HT4-SKIT-V2	All	Nitrile	Main Valve Seal and Adaptor O-ring	25	200
¾	HT5-SKIT-V2	All	Nitrile	Main Valve Seal and Adaptor O-ring	25	200
¾	HT6-SKIT-V2	All	Nitrile	Main Valve Seal and Adaptor O-ring	25	200
1	HT8-SKIT-V2	All	Nitrile	Main Valve Seal and Adaptor O-ring	25	200

- NPTF and ORB thread styles also available
- A complete range of seal options are available

E

FOR TECHNICAL GUIDELINES PLEASE REFER TO PAGE 217



+44 (0)1772 323529  
europe.dixonvalve.com  
sale@technobearing.ru

TECHNOBEARING.RU

**DGEL2020**  
8 (800) 700-72-07



## HTE-Series Hydraulic Couplings

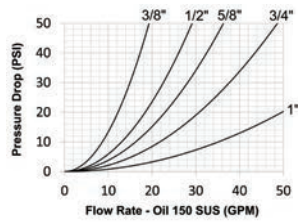

<b>Materials:</b>	<ul style="list-style-type: none"> <li>Machined components are manufactured using solid steel bar stock</li> <li>Steel componentry is plated using a ROHS-compliant zinc nickel process providing superior corrosion resistance</li> <li>Stainless steel retaining rings and springs maximise corrosion resistance and extend service life</li> <li>Nipples are hardened to provide resistance to brinelling during impulse service</li> </ul>
<b>Seal Components:</b>	<ul style="list-style-type: none"> <li>3/8\", 1/2\", and 3/4\" nipples have molded polyurethane valve seals, with a temperature range of <b>-54°C to 100°C (-65°F to 212°F)</b></li> <li>5/8\" and 1\" nipples have nitrile-energised PTFE valve seals, with a temperature range of <b>-40°C to 121°C (-40°F to 249°F)</b></li> <li>Ancillary nipple seals are nitrile (buna-N), temperature range of <b>-40°C to 121°C (-40°F to 249°F)</b></li> </ul>
<b>Interchange Data:</b>	<ul style="list-style-type: none"> <li>Parker FEC-Series, Stucchi APM-Series, Faster 3FFH-Series</li> </ul>

### Component Terminology

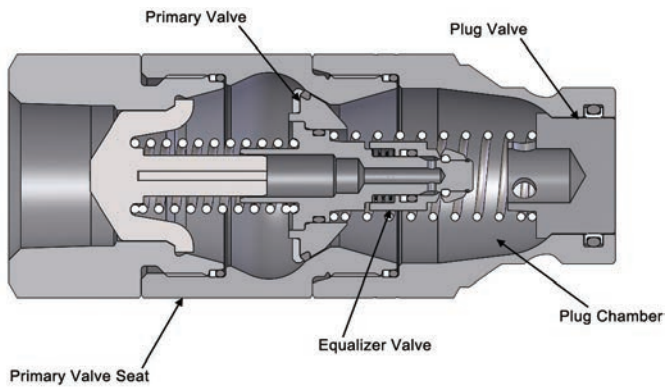

### Benefits of the Equalizer valve system

- Non-linear connection force at all pressures
- No maximum connection-pressure restrictions
- Head pressure or valve bleed-by has minimal effect on connection force
- Less susceptible to system contamination
- Design is scalable, performing similarly in all sizes
- Smooth connection action

### Rated Pressure Chart:

Size (inch)	HTE-Series ISO16028 Connect Under Pressure Flushface Nipple											
	Steel HT Coupler / HTE Plug Coupled				HTE-Plug Uncoupled				Air Inclusion	Fluid Loss	Vacuum inch HG	Flow LPN
	Max. Working		Burst		Max. Working		Burst					
PSI	Bar	PSI	Bar	PSI	Bar	PSI	Bar					
3/8	5,000	345	20,000	1380	5,000	345	20,000	1380	n/a	0.010cc	N/R	36
1/2	5,000	345	20,000	1380	5,000	345	20,000	1380	n/a	0.010cc	N/R	56
5/8	5,000	345	20,000	1380	5,000	345	20,000	1380	n/a	0.020cc	N/R	68
3/4	5,000	345	20,000	1380	5,000	345	20,000	1380	n/a	0.030cc	N/R	91
1	5,000	345	20,000	1380	5,000	345	20,000	1380	n/a	0.030cc	N/R	166



## HTE-Series Hydraulic Couplings

### The Equalizer Connection Process

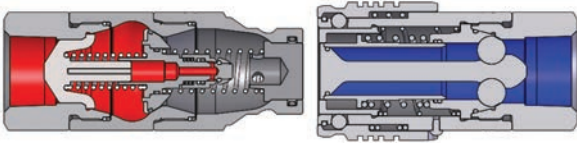

Stage 1: The Disconnected State

The plug has residual pressure trapped behind the primary valve, while the coupler has no trapped pressure.

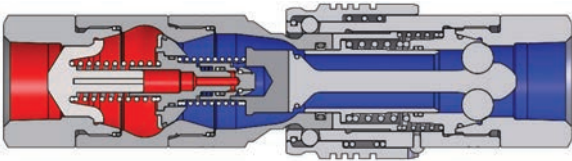

Stage 2: Plug Chamber Evacuated

The plug valve is opened, then the socket valve opens, evacuating the plug chamber to the unpressurised socket.

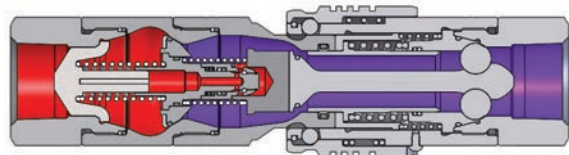

Stage 3: Release Pressure

The connection continues, with the Equalizer valve being activated, releasing the trapped pressure into the plug chamber, then to the unpressurised socket.

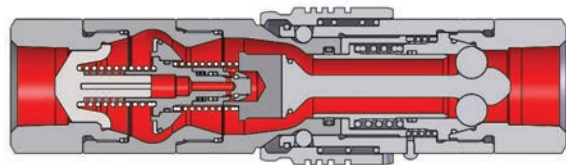

Stage 4: Complete the connection

The primary valve can now open easily, since there is no longer any pressure trapped behind it, allowing the socket to fully engage the plug.

E

FOR TECHNICAL GUIDELINES PLEASE REFER TO PAGE 223

## HTE-Series Hydraulic Couplings

HTE-Series ISO 16028 Connect Under Pressure Flush Face Nipple (Female Threads)											
Size (inch)	Part Detail			Length		Maximum OD		Hex (mm)	Weight (kg)	Package Qty	
	Part No.	Threads	Material	inch	mm	inch	mm			Bag	Box
3/8	HTE3F4	1/2"-14 NPTF	Steel	3.25	82.6	1.30	33.0	1 1/8"	0.43	-	10
3/8	HTE3BF4	1/2"-14 BSPP	Steel	3.25	82.6	1.30	33.0	1 1/8"	0.43	-	10
3/8	HTE3OF4	3/4"-16 ORB	Steel	3.25	82.6	1.30	33.0	1 1/8"	0.43	-	10
1/2	HTE4F4	1/2"-14 NPTF	Steel	3.40	86.4	1.30	33.0	1-3/16"	0.49	-	10
1/2	HTE4BF4	1/2"-14 BSPP	Steel	3.40	86.4	1.30	33.0	1-3/16"	0.49	-	10
1/2	HTE4OF4	3/4"-16 ORB	Steel	3.40	86.4	1.30	33.0	1-3/16"	0.49	-	10
1/2	HTE4OF5	7/8"-14 ORB	Steel	3.40	86.4	1.30	33.0	1 1/2"	0.50	-	10
1/2	HTE4F6	3/4"-14 NPTF	Steel	3.60	91.4	1.65	41.9	1 1/2"	0.50	-	10
1/2	HTE4BF6	3/4"-14 BPSS	Steel	3.60	91.4	1.65	41.9	1 1/2"	0.50	-	10
1/2	HTE4OF6	1-1/16"-12 ORB	Steel	3.60	91.4	1.65	41.9	1 1/2"	0.50	-	10
5/8	HTE5OF5	7/8"-14 ORB	Steel	3.75	95.3	1.65	41.9	1 1/2"	0.70	-	10
5/8	HTE5F6	3/4"-14 NPTF	Steel	3.75	95.3	1.65	41.9	1 1/2"	0.70	-	10
5/8	HTE5BF6	3/4"-14 BSPP	Steel	3.75	95.3	1.65	41.9	1 1/2"	0.70	-	10
5/8	HTE5OF6	1-1/16"-12 ORB	Steel	3.75	95.3	1.65	41.9	1 1/2"	0.80	-	10
3/4	HTE6F6	3/4"-14 NPTF	Steel	4.25	108.0	1.96	49.8	1 1/2"	0.82	-	5
3/4	HTE6BF6	3/4"-14 BSPP	Steel	4.25	108.0	1.96	49.8	1 1/2"	0.82	-	5
3/4	HTE6OF6	1-1/16"-12 ORB	Steel	4.25	108.0	1.96	49.8	1 1/2"	0.82	-	5
3/4	HTE6F8	1"-11 1/2 NPTF	Steel	4.40	111.8	1.96	49.8	1 3/4"	0.95	-	5
3/4	HTE6BF8	1"-11 BSPP	Steel	4.40	111.8	1.96	49.8	1 3/4"	0.95	-	5
3/4	HTE6OF8	1-5/16"-12 ORB	Steel	4.40	111.8	1.96	49.8	1 3/4"	0.95	-	5
1	HTE8F8	1"-11 1/2 NPTF	Steel	4.88	124.0	1.96	49.8	1 3/4"	0.98	-	5
1	HTE8BF8	1"-11 BSPP	Steel	4.88	124.0	1.96	49.8	1 3/4"	0.98	-	5
1	HTE8OF8	1-5/16"-12 ORB	Steel	4.88	124.0	1.96	49.8	1 3/4"	0.98	-	5
1	HTE8F10	1 1/4"-11 1/2 NPTF	Steel	5.00	127.0	2.47	62.7	2-3/16"	1.08	-	5
1	HTE8BF10	1 1/4"-11 BSPP	Steel	5.00	127.0	2.47	62.7	2-3/16"	1.08	-	5
1	HTE8OF10	1 5/8"-12 ORB	Steel	5.00	127.0	2.47	62.7	2-3/16"	1.08	-	5

• For use with HT-Series Couplers

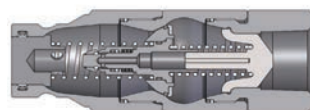

FOR TECHNICAL GUIDELINES PLEASE REFER TO PAGE 223

## HTZ-Series Hydraulic Couplings

**Materials:**

- For use with HT or HTE series plugs
- Connectable with trapped pressure on HTE half only
- Connect under pressure up to **1500 PSI** at **21°C (70°F)**
- Pressure rating **5000 PSI** at **21°C (70°F)**

Body Size (inch)	Part No.	Threads
1/2	4HTZF4	1/2"-14 NPTF
1/2	4HTZF6	3/4"-14 NPTF
1/2	4HTZOF4	3/4"-16 ORB
1/2	4HTZOF5	7/8"-14 ORB
1/2	4HTZOF6	1 1/16"-12 ORB



## ST-Series Snap-Tite 71 Interchange

<b>Materials:</b>	<ul style="list-style-type: none"> <li>Machined components are manufactured using solid steel or 316 stainless steel bar stock</li> <li>Stainless steel balls, retaining rings, and springs maximise corrosion resistance and extend service life</li> <li>Steel componentry is plated using ROHS-compliant trivalent chrome</li> <li>Steel coupler sleeves are hardened to resist deformation and maximise service life</li> <li>Steel nipples are hardened to provide heavy-duty performance</li> </ul>
<b>Seal Components:</b>	<ul style="list-style-type: none"> <li>Nitrile (Buna-N) seals are standard, providing a temperature range of <b>-40°C to 121°C (-40°F to 249°F)</b></li> <li>All couplers and nipples incorporate PTFE or TPC-ET anti-extrusion rings to protect the seal components from dynamic impulse damage</li> </ul>
<b>Interchange Data:</b>	<ul style="list-style-type: none"> <li>Interchangeable with Snap-Tite 71-Series</li> </ul>

Size (inch)	Steel Coupler / Plug Coupled				316SS Coupler / Plug Coupled			
	Working Pressure		Burst Pressure		Working Pressure		Burst Pressure	
	PSI	Bar	PSI	Bar	PSI	Bar	PSI	Bar
¼	10,000	700	27,300	1800	5,000	345	28,000	1900
¾	10,000	700	27,300	1800	5,000	345	28,000	1900
½	10,000	700	22,500	1500	5,000	345	25,000	1700
¾	7,500	500	20,200	1400	5,000	345	22,800	1550
1	7,500	500	19,400	1300	4,000	275	18,500	1250
1-V2	8,500	585	25,900	1750	-	-	-	-
2	5,000	345	16,000	1100	3,000	200	10,000	700

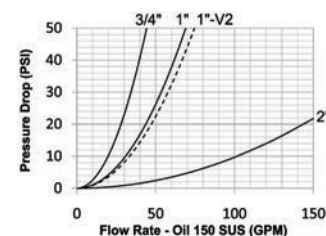
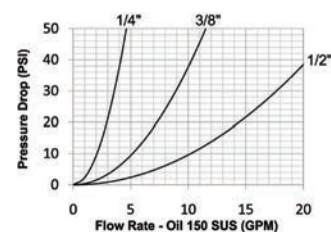

E

Size (inch)	Interchange Standards				Functional Parameters					
	US Military	US Government	International Standards	ANSI / NFPA Standards	Locking Ball Qty	Air Inclusion	Fluid Loss	Vacuum inch HG	Flow (Lpm) ΔP = 22 PSI	
¼	-	-	-	-	10	0.01cc	0.02cc	N/R	11.7	
¾	-	-	-	-	10	0.02cc	0.02cc	N/R	29	
½	-	-	-	-	12	0.03cc	0.03cc	N/R	57	
¾	-	-	-	-	12	0.04cc	0.06cc	N/R	114	
1	-	-	-	-	12	0.06cc	0.07cc	N/R	170	
1-V2	-	-	-	-	12	0.09cc	0.10cc	N/R	190	
2	-	-	-	-	15	3.14cc	5.25cc	N/R	568	

### ST-Series Interchange

Size (inch)	Snap Tite	PCI
¾	Series 71	71FF
1	Series 71	71FF
2	Series 71	71FF



Although a special lubricant is used to protect the flush face seals during pre-service storage, the seals are still vulnerable until they are exposed to the system fluid. It is recommended to lubricate the seals before the first connection by placing a drop of oil into the main valve grooves on the face of the nipple and coupler.

## ST-Series Snap-Tite Interchange Seal Kits

### ST-Series Snap-Tite 71-Series Coupler Seal Kits

Size (inch)	Part No.	Coupler Style	Seal Material	Seal Kits Contents	Pkg Qty	
					Bag	Box
¼	2ST-SKIT	All	Nitrile	Two Seals & Anti-Extrusion Rings	25	200
¾	3ST-SKIT	All	Nitrile	Two Seals & Anti-Extrusion Rings	25	200
½	4ST-SKIT	All	Nitrile	Two Seals & Anti-Extrusion Rings	25	200
¾	6ST-SKIT	All	Nitrile	Two Seals & Anti-Extrusion Rings	25	200
1	8ST-SKIT	All	Nitrile	Two Seals & Anti-Extrusion Rings	25	200
1	8ST-SKIT-V2	All	Nitrile	Three Seals & Two Anti-Extrusion Rings	25	200
2	16ST-SKIT	All	Nitrile	Three Seals & Two Anti-Extrusion Rings	10	100

- NPTF and ORB thread styles also available
- A complete range of seal options are available



## ST-Series Snap-Tite Interchange Seal Kits

ST-Series Snap-Tite 71-Series Nipple Seal Kits							
Size (inch)	Part No.	Coupler Style	Seal Material	Seal Kits Contents	Pkg Qty		
					Bag	Box	
¼	ST2-SKIT	All	Nitrile	Valve O-ring / Back-up & Adaptor O-ring	25	200	
¾	ST3-SKIT	All	Nitrile	Valve O-ring / Back-up & Adaptor O-ring	25	200	
½	ST4-SKIT	All	Nitrile	Valve O-ring / Back-up & Adaptor O-ring	25	200	
¾	ST6-SKIT	All	Nitrile	Valve O-ring / Back-up & Adaptor O-ring	25	200	
1	ST8-SKIT	All	Nitrile	Valve O-ring / Back-up & Adaptor O-ring	25	200	
2	ST16-SKIT	All	Nitrile	Main Valve Seal	25	200	

## ST-Series Profiles

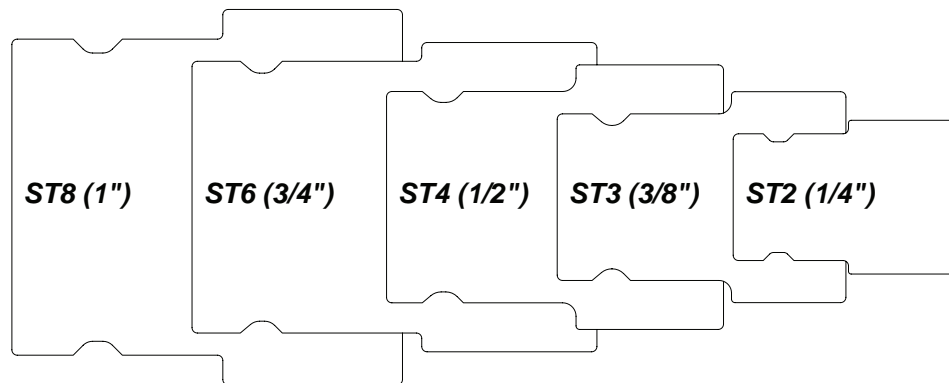

Size (inch)	A (mm)	B (mm)
¼	17.66	4.76
¾	23.81	4.76
½	30.16	4.76
¾	38.10	6.35
1	44.45	7.94
ST8-V2 1	39.69	20.64
2	69.85	36.51



## ST-Series Coupler Rigid Dust Plugs

Size (inch)	Part No.	Cap Lanyard	Body Material	Weight (kg)	Pkg Qty	
					Bag	Box
¼	2STDP-A	SS Bead Chain	Aluminium	0.06	5	25
¾	3STDP-A	SS Bead Chain	Aluminium	0.08	5	25
½	4STDP-A	SS Bead Chain	Aluminium	0.10	5	25
¾	6STDP-A	SS Bead Chain	Aluminium	0.16	-	10
1	8STDP-A	SS Bead Chain	Aluminium	0.17	-	10
1-V2	8STDP-A-V2	SS Bead Chain	Aluminium	0.22	-	10
2	16STDP-A	SS Bead Chain	Aluminium	0.42	-	1



## ST-Series Nipple Rigid Dust Caps

Size (Inch)	Part No.	Cap Lanyard	Body Material	Weight (kg)	Pkg Qty	
					Bag	Box
¼	ST2DC-A	SS Bead Chain	Aluminium	0.07	5	25
¾	ST3DC-A	SS Bead Chain	Aluminium	0.08	5	25
½	ST4DC-A	SS Bead Chain	Aluminium	0.10	5	25
¾	ST6DC-A	SS Bead Chain	Aluminium	0.12	-	10
1	ST8DC-A	SS Bead Chain	Aluminium	0.13	-	10
1-V2	ST8DC-A-V2	SS Bead Chain	Aluminium	0.21	-	10
2	ST16DC-A	SS Bead Chain	Aluminium	0.34	-	1



- NPTF and ORB thread styles also available
- A complete range of seal options are available

FOR TECHNICAL GUIDELINES PLEASE REFER TO PAGE 226



+44 (0)1772 323529  
europe.dixonvalve.com

sale@technobearing.ru

TECHNOBEARING.RU

DGEL2020  
8 (800) 700-72-07

## ST-Series Automatic Couplers



Female Thread

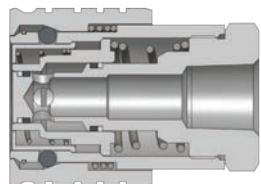

Size (inch)	Part No.	Thread Size (inch)	Body Material	Weight (kg)	Pkg Qty	
					Bag	Box
¼	2STF2	¼ - 18 NPTF	Steel	0.11	5	25
¼	2STF2-SS	¼ - 18 NPTF	316 SS	0.12	5	25
¼	2STBF2	¼ - 19 BSPP	Steel	0.11	5	25
¼	2STBF2-SS	¼ - 19 BSPP	316 SS	0.12	5	25
⅜	3STF2	¼ - 18 NPTF	Steel	0.17	5	25
⅜	3STF3	⅜ - 18 NPTF	Steel	0.16	5	25
⅜	3STF3-SS	⅜ - 18 NPTF	316 SS	0.17	5	25
⅜	3STBF3	⅜ - 19 BSPP	Steel	0.16	5	25
⅜	3STBF3-SS	⅜ - 19 BSPP	316 SS	0.17	5	25
⅜	3STF4	½ - 14 NPTF	Steel	0.16	5	25
⅜	3STF4-SS	½ - 14 NPTF	316 SS	0.16	5	25
⅜	3STBF4	½ - 14 BSPP	Steel	0.16	5	25
⅜	3STBF4-SS	½ - 14 BSPP	316 SS	0.16	5	25
½	4STF4	½ - 14 NPTF	Steel	0.21	-	20
½	4STF4-SS	½ - 14 NPTF	316 SS	0.22	-	20
½	4STBF4	½ - 14 BSPP	Steel	0.21	-	20
½	4STBF4-SS	½ - 14 BSPP	316 SS	0.22	-	20
½	4STOF4	¾ - 16 ORB	Steel	0.22	-	20
¾	6STF6	¾ - 14 NPTF	Steel	0.90	-	10
¾	6STF6-SS	¾ - 14 NPTF	316 SS	0.93	-	10
¾	6STBF6	¾ - 14 BSPP	Steel	0.90	-	10
¾	6STBF6-SS	¾ - 14 BSPP	316 SS	0.93	-	10
¾	6STOF6	1⅞ - 12 ORB	Steel	0.90	-	10
1	8STF8	1 - 11½ NPTF	Steel	1.26	-	10
1	8STF8-SS	1 - 11½ NPTF	316 SS	1.28	-	10
1	8STBF8	1 - 11 BSPP	Steel	1.26	-	10
1	8STBF8-SS	1 - 11 BSPP	316 SS	1.28	-	10
1	8STOF8	1⅞ - 12 ORB	Steel	1.23	-	10
1	8STF10	1¼ - 11½ NPTF	Steel	1.29	-	10
1	8STF10-SS	1¼ - 11½ NPTF	316 SS	1.31	-	10
1	8STBF10	1¼ - 11 BSPP	Steel	1.29	-	10
1	8STBF10-SS	1¼ - 11 BSPP	316 SS	1.31	-	10
1	8STOF10	1⅞ - 12 ORB	Steel	1.26	-	10

## ST-Series 'Old Style' Couplers



Female Thread

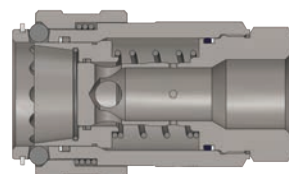

Size (inch)	Part No.	Thread Size (inch)	Body Material	Weight (kg)	Pkg Qty	
					Bag	Box
1	8STF8-V2	1 - 11½ NPTF	Steel	1.28	-	10
1	8STBF8-V2	1 - 11 BSPP	Steel	1.28	-	10
1	8STF10-V2	1¼ - 11½ NPTF	Steel	1.30	-	10
2	16STF12	1½ - 11½ NPTF	Steel	4.11	-	1
2	16STBF12	1½ - 11 BSPP	Steel	4.11	-	1
2	16STOF12	1⅞ - 12 ORB	Steel	4.06	-	1
2	16STF16	2 - 11½ NPTF	Steel	3.96	-	1
2	16STF16-SS	2 - 11½ NPTF	316 SS	3.96	-	1
2	16STBF16	2 - 11 BSPP	Steel	3.96	-	1
2	16STOF16	2½ - 12 ORB	Steel	3.91	-	1

- NPTF and ORB thread styles also available
- A complete range of seal options are available

FOR TECHNICAL GUIDELINES PLEASE REFER TO PAGE 226

## ST-Series Nipples

Size (inch)	Part No.	Thread Size (inch)	Body Material	Weight (kg)	Pkg Qty	
					Bag	Box
¼	ST2F2	¼ - 18 NPTF	Steel	0.07	5	25
¼	ST2F2-SS	¼ - 18 NPTF	316 SS	0.07	5	25
¼	ST2BF2	¼ - 19 BSPP	Steel	0.07	5	25
¼	ST2BF2-SS	¼ - 19 BSPP	316 SS	0.07	5	25
⅜	ST3F2	¼ - 18 NPTF	Steel	0.13	5	25
⅜	ST3F3	⅜ - 18 NPTF	Steel	0.12	5	25
⅜	ST3F3-SS	⅜ - 18 NPTF	316 SS	0.12	5	25
⅜	ST3BF3	⅜ - 19 BSPP	Steel	0.12	5	25
⅜	ST3BF3-SS	⅜ - 19 BSPP	316 SS	0.12	5	25
⅜	ST3F4	½ - 14 NPTF	Steel	0.12	5	25
⅜	ST3F4-SS	½ - 14 NPTF	316 SS	0.12	5	25
⅜	ST3BF4	½ - 14 BSPP	Steel	0.12	5	25
⅜	ST3BF4-SS	½ - 14 BSPP	316 SS	0.12	5	25
½	ST4F4	½ - 14 NPTF	Steel	0.19	-	20
½	ST4F4-SS	½ - 14 NPTF	316 SS	0.19	-	20
½	ST4BF4	½ - 14 BSPP	Steel	0.19	-	20
½	ST4BF4-SS	½ - 14 BSPP	316 SS	0.19	-	20
½	ST4OF4	¾ - 16 ORB	Steel	0.19	-	20
¾	ST6F6	¾ - 14 NPTF	Steel	0.49	-	10
¾	ST6F6-SS	¾ - 14 NPTF	316 SS	0.52	-	10
¾	ST6BF6	¾ - 14 BSPP	Steel	0.49	-	10
¾	ST6BF6-SS	¾ - 14 BSPP	316 SS	0.52	-	10
¾	ST6OF6	1 ⅙ - 12 ORB	Steel	0.46	-	10
1	ST8F8	1 - 11 ½ NPTF	Steel	0.67	-	10
1	ST8F8-SS	1 - 11 ½ NPTF	316 SS	0.70	-	10
1	ST8BF8	1 - 11 BSPP	Steel	0.67	-	10
1	ST8BF8-SS	1 - 11 BSPP	316 SS	0.70	-	10
1	ST8OF8	1 ⅙ - 12 ORB	Steel	0.62	-	10
1	ST8F10	1 ¼ - 11 ½ NPTF	Steel	0.60	-	10
1	ST8F10-SS	1 ¼ - 11 ½ NPTF	316 SS	0.77	-	10
1	ST8BF10	1 ¼ - 11 BSPP	Steel	0.60	-	10
1	ST8BF10-SS	1 ¼ - 11 BSPP	316 SS	0.76	-	10
1	ST8OF10	1 ⅝ - 12 ORB	Steel	0.70	-	10



Female Thread

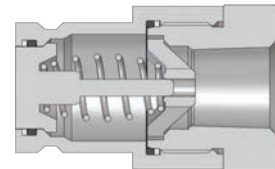

## ST-Series 'Old Style' Nipples

Size (inch)	Part No.	Thread Size (inch)	Body Material	Weight (kg)	Pkg Qty	
					Bag	Box
1	ST8F8-V2	1 - 11 ½ NPTF	Steel	0.69	-	10
1	ST8BF8-V2	1 - 11 BSPP	Steel	0.67	-	10
1	ST8F10-V2	1 ¼ - 11 ½ NPTF	Steel	0.67	-	10
2	ST16F12	1 ½ - 11 ½ NPTF	Steel	1.96	-	1
2	ST16BF12	1 ½ - 11 BSPP	Steel	1.96	-	1
2	ST16OF12	1 ⅞ - 12 ORB	Steel	1.91	-	1
2	ST16F16	2 - 11 ½ NPTF	Steel	1.88	-	1
2	ST16F16-SS	2 - 11 ½ NPTF	316 SS	1.88	-	1
2	ST16BF16	2 - 11 BSPP	Steel	1.88	-	1
2	ST16OF16	2 ½ - 12 ORB	Steel	1.84	-	1



Female Thread

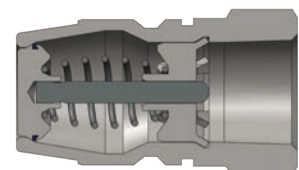

- NPTF and ORB thread styles also available
- A complete range of seal options are available

FOR TECHNICAL GUIDELINES PLEASE REFER TO PAGE 226



# Hydraulic & Pneumatic

## AG-Series Agricultural Interchange

<b>Features:</b>	<ul style="list-style-type: none"> <li>Dixon™ carries two valve styles for the agricultural coupling series, ball valve and poppet valve. The ball valve coupling has historically provided greater longevity, while the poppet valve will improve flow while in operation.</li> </ul>
<b>Materials:</b>	<ul style="list-style-type: none"> <li>Machined components are manufactured using solid steel bar stock</li> <li>Stainless steel balls, retaining rings, and springs maximise corrosion resistance and extend service life</li> <li>Steel componentry is plated using ROHS-compliant trivalent chrome</li> <li>Steel coupler sleeves are hardened to resist deformation and maximise service life</li> <li>Steel nipples are hardened to provide heavy-duty performance and resist brinelling</li> </ul>
<b>Seal Components:</b>	<ul style="list-style-type: none"> <li>Nitrile (Buna-N) seals are standard providing a temperature range of <b>-40°C to 121°C (-40°F to 249°F)</b></li> <li>Couplers have a PTFE anti-extrusion ring</li> <li>Poppet valve seals are crimped in place to maintain integrity during excessive flow conditions and pressurised connection</li> <li>Piloted ball valve has a seal that is crimped to prevent low-pressure leakage</li> </ul>
<b>Interchange Data:</b>	<ul style="list-style-type: none"> <li>Pioneer agricultural interchange</li> <li>Parker/Pioneer 4000 Series, Faster NS/NV-Series</li> <li>Safeway Series-S20, Stucchi IR-Series, Snap-Tite 60-Series, RYCO R91 &amp; R94 Series</li> </ul>
<b>Standards:</b>	<ul style="list-style-type: none"> <li>AG-Series couplers and nipples are compliant with the parameters outlined in ISO5675 (ISO7241-1 Series A for the ½" size)</li> </ul>

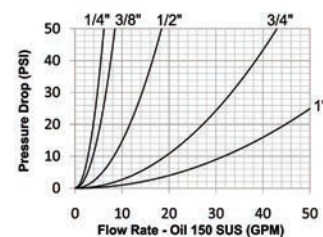

Size (inch)	Ball Steel Coupler / Plug				Poppet Steel Coupler / Plug			
	Working Pressure		Burst Pressure		Working Pressure		Burst Pressure	
	PSI	Bar	PSI	Bar	PSI	Bar	PSI	Bar
¼	4,000	275	24,400	1700	4,000	275	21,000	1500
⅜	4,000	275	25,000	1700	4,000	275	23,100	1600
½	4,000	275	16,500	1100	4,000	275	16,500	1100
¾	3,000	200	15,800	1050	3,000	200	10,300	700
1	3,000	200	13,500	900	3,000	200	13,000	900

Interchange Standards					Functional Parameters				
Size (inch)	US Military	US Government	International Standards	ANSI / NFPA Standards	Locking Ball Qty	Air Inclusion	Fluid Loss	Vacuum inch HG	Flow (Lpm) ΔP = 22 PSI
¼	-	-	-	-	8	1.1cc	0.9cc	26.5	15
⅜	-	-	-	-	9	2.6cc	1.8cc	26.5	23
½	-	-	ISO7241 'A'	-	9	3.8cc	2.9cc	26.5	45
¾	-	-	ISO5675	-	12	10.8cc	9.7cc	26.5	106
1	-	-	-	-	12	15.9cc	15.3cc	26.5	182

AG-Series Interchange						
Size (inch)	Parker / Pioneer	Faster	Tomco	Safeway	Stucchi	Snap-Tite
¼	4000 Series	NS	Series PC	Series S20	IR-Series	60-Series
⅜	4000 Series	NS	Series PC	Series S20	IR-Series	60-Series
½	4000 Series	NS	Series PC	Series S20	IR-Series	60-Series
¾	4000 Series	NS	Series PC	Series S20	IR-Series	60-Series
1	4000 Series	NS	Series PC	Series S20	IR-Series	60-Series

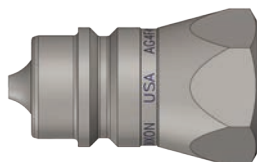

Poppet Valve Style (-PV)



Standard Ball Valve Style

- NPTF and ORB thread styles also available
- A complete range of seal options are available



## AG-Series Profiles

Size (inch)	A (mm)	B (mm)
¼	14.29	7.94
⅜	19.05	8.73
½	15.85	7.94
¾	23.81	11.11
1	30.16	9.53

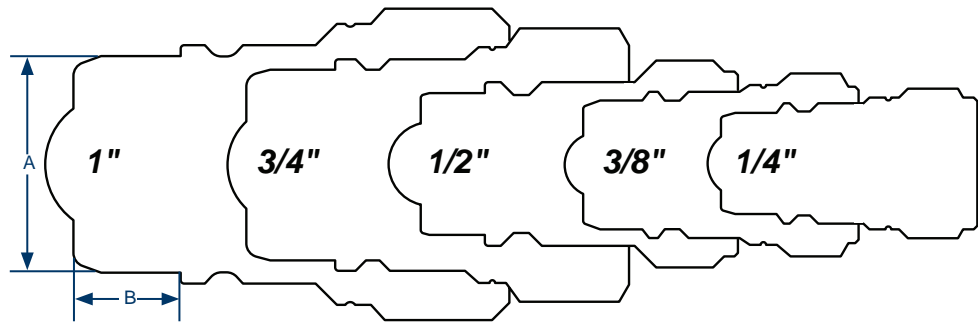

## AG-Series Coupler Dust Plugs

Size (inch)	Part No.	Cap Lanyard	Body Material	Weight (kg)	Pkg Qty	
					Bag	Box
¼	2AGDP	Elastomer	Elastomer	0.01	10	50
½	4AGDP	Elastomer	Elastomer	0.02	10	50
1	8AGDP	Elastomer	Elastomer	0.04	5	25



## AG-Series Nipple Dust Caps

Size (inch)	Part No.	Cap Lanyard	Body Material	Weight (kg)	Pkg Qty	
					Bag	Box
¼	AG2DC	Elastomer	Elastomer	0.01	10	50
½	AG4DC	Elastomer	Elastomer	0.02	10	50
1	AG8DC	Elastomer	Elastomer	0.04	5	25



## AG-Series Ball Couplers

Size (inch)	Part No.	Thread Size (inch)	Body Material	Weight (kg)	Pkg Qty	
					Bag	Box
¼	2AGF2	¼ - 18 NPTF	Steel	0.11	10	100
⅜	3AGF3	⅜ - 18 NPTF	Steel	0.23	10	50
½	4AGF4	½ - 14 NPTF	Steel	0.26	5	25
½	4AGBF4	½ - 14 BSPP	Steel	0.26	5	25
½	4AGOF4	¾ - 16 ORB	Steel	0.29	5	25
½	4AGOF5	⅞ - 14 ORB	Steel	0.26	5	25
½	4AGF6	¾ - 14 NPTF	Steel	0.32	5	25
½	4AGBF6	¾ - 14 BSPP	Steel	0.32	5	25
¾	6AGF6	¾ - 14 NPTF	Steel	0.45	-	10
¾	6AGBF6	¾ - 14 BSPP	Steel	0.45	-	10
1	8AGF8	1 - 11½ NPTF	Steel	0.88	-	10
1	8AGBF8	1 - 11½ BSPP	Steel	0.88	-	10

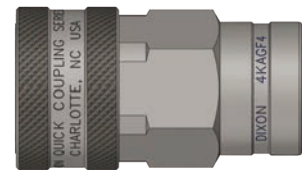

Female Thread

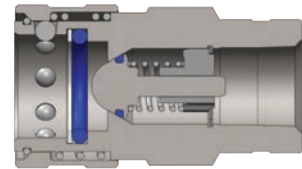

## AG-Series Poppet Couplers

Size (inch)	Part No.	Thread Size (inch)	Body Material	Weight (kg)	Pkg Qty	
					Bag	Box
¼	2AGF2-PV	¼ - 18 NPTF	Steel	0.11	10	100
¼	2AGBF2-PV	¼ - 18 BSPP	Steel	0.11	10	100
⅜	3AGF3-PV	⅜ - 18 NPTF	Steel	0.23	10	50
⅜	3AGBF3-PV	⅜ - 18 BSPP	Steel	0.23	10	50
½	4AGF4-PV	½ - 14 NPTF	Steel	0.26	5	25
½	4AGBF4-PV	½ - 14 BSPP	Steel	0.26	5	25
½	4AGOF4-PV	¾ - 16 ORB	Steel	0.29	5	25
½	4AGOF5-PV	⅞ - 14 ORB	Steel	0.26	5	25
½	4AGF6-PV	¾ - 14 NPTF	Steel	0.32	5	25
½	4AGBF6-PV	¾ - 14 BSPP	Steel	0.32	5	25
¾	6AGF6-PV	¾ - 14 NPTF	Steel	0.45	-	10
¾	6AGBF6-PV	¾ - 14 BSPP	Steel	0.45	-	10
1	8AGF8-PV	1 - 11½ NPTF	Steel	0.88	-	10
1	8AGBF8-PV	1 - 11½ BSPP	Steel	0.88	-	10

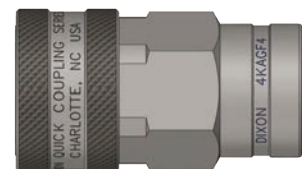

Female Thread

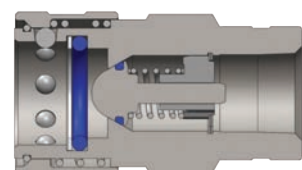

- ORB thread styles also available.
- A complete range of seal options are available

FOR TECHNICAL GUIDELINES PLEASE REFER TO PAGE 230



# Hydraulic & Pneumatic

## AG-Series Push-Pull Ball Couplers

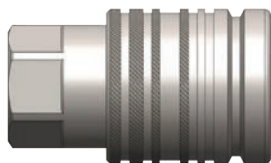

Female Thread

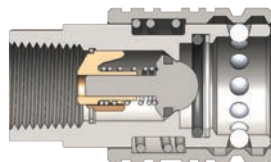

Size (inch)	Part No.	Thread Size (inch)	Body Material	Weight (kg)	Pkg Qty	
					Bag	Box
3/8	3AGF3-PS	3/8 - 18 NPTF	Steel	0.24	5	25
1/2	4AGF4-PS	1/2 - 14 NPTF	Steel	0.34	5	25
1/2	4AGOF4-PS	3/4 - 16 ORB	Steel	0.34	5	25
1/2	4AGOF5-PS	7/8 - 14 ORB	Steel	0.34	5	25
1/2	4AGF6-PS	3/4 - 14 NPTF	Steel	0.34	5	25

## AG-Series Push-Pull Poppet Couplers

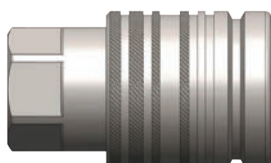

Female Thread

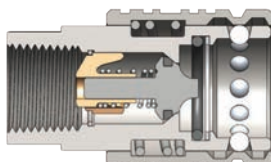

Size (inch)	Part No.	Thread Size (inch)	Body Material	Weight (kg)	Pkg Qty	
					Bag	Box
3/8	3AGF3-PV-PS	3/8 - 18 NPTF	Steel	0.23	5	25
1/2	4AGF4-PV-PS	1/2 - 14 NPTF	Steel	0.34	5	25
1/2	4AGOF4-PV-PS	3/4 - 16 ORB	Steel	0.37	5	25
1/2	4AGOF5-PV-PS	7/8 - 14 ORB	Steel	0.34	5	25
1/2	4AGF6-PV-PS	3/4 - 14 NPTF	Steel	0.34	5	25

## AG-Series Ball Nipples



Female Thread

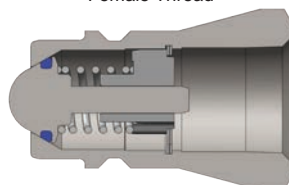

Size (inch)	Part No.	Thread Size (inch)	Body Material	Weight (kg)	Pkg Qty	
					Bag	Box
1/4	AG2F2	1/4 - 18 NPTF	Steel	0.04	10	100
1/4	AG2BF2	1/4 - 18 BSPP	Steel	0.04	10	100
3/8	AG3BF3	3/8 - 18 BSPP	Steel	0.07	10	50
1/2	AG4F4	1/2 - 14 NPTF	Steel	0.09	5	25
1/2	AG4BF4	1/2 - 14 BSPP	Steel	0.09	5	25
1/2	AG4OF4	3/4 - 16 ORB	Steel	0.11	5	25
1/2	AG4F6	3/4 - 14 NPTF	Steel	0.11	5	25
1/2	AG4BF6	3/4 - 14 BSPP	Steel	0.11	5	25
3/4	AG6F6	3/4 - 14 NPTF	Steel	0.22	-	10
3/4	AG6BF6	3/4 - 14 BSPP	Steel	0.22	-	10
1	AG8F8	1 - 11 1/2 NPTF	Steel	0.28	-	10
1	AG8BF8	1 - 11 1/2 BSPP	Steel	0.28	-	10

## AG-Series Poppet Nipples

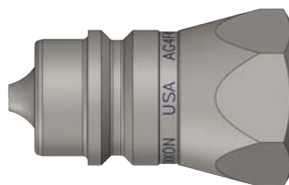

Female Thread

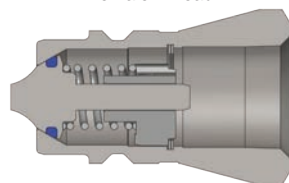

Size (inch)	Part No.	Thread Size (inch)	Body Material	Weight (kg)	Pkg Qty	
					Bag	Box
1/4	AG2F2-PV	1/4 - 18 NPTF	Steel	0.04	10	100
1/4	AG2BF2-PV	1/4 - 19 BSPP	Steel	0.04	10	100
3/8	AG3F3-PV	3/8 - 18 NPTF	Steel	0.07	10	50
3/8	AG3BF3-PV	3/8 - 19 BSPP	Steel	0.07	10	50
1/2	AG4F4-PV	1/2 - 14 NPTF	Steel	0.09	5	25
1/2	AG4BF4-PV	1/2 - 14 BSPP	Steel	0.09	5	25
1/2	AG4OF4-PV	3/4 - 16 ORB	Steel	0.11	5	25
1/2	AG4OF5-PV	7/8 - 14 ORB	Steel	0.11	5	25
1/2	AG4F6-PV	3/4 - 14 NPTF	Steel	0.11	5	25
1/2	AG4BF6-PV	3/4 - 14 BSPP	Steel	0.11	5	25
3/4	AG6F6-PV	3/4 - 14 NPTF	Steel	0.22	-	10
3/4	AG6BF6-PV	3/4 - 14 BSPP	Steel	0.22	-	10
1	AG8F8-PV	1 - 11 1/2 NPTF	Steel	0.28	-	10
1	AG8BF8-PV	1 - 11 BSPP	Steel	0.28	-	10

• ORB thread styles also available.

• A complete range of seal options are available

FOR TECHNICAL GUIDELINES PLEASE REFER TO PAGE 230

## T-Series High Pressure Screw-Together

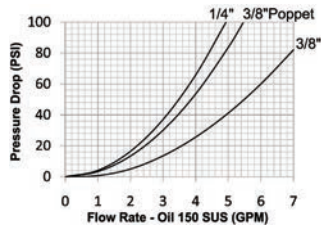

- |                          |   |
|--------------------------|---|
| <b>Materials:</b>        | <ul style="list-style-type: none"> <li>Machined components are manufactured using solid steel or 316 stainless steel bar stock</li> <li>Chrome steel ball valve is mechanically seated to improve low-pressure sealing performance</li> <li>Steel componentry is plated using ROHS-compliant trivalent chrome</li> <li>Steel nipples are machined from solid high-strength steel bar stock</li> </ul> |
| <b>Seal Components:</b>  | <ul style="list-style-type: none"> <li>Urethane seal is standard in ball valve couplers and provides resistance to extrusion when subjected to high pressure. Temperature range is <b>-40°C to 82°C (-40°F to 179°F)</b></li> <li>Nitrile seals are standard in poppet valve couplings, providing a temperature range of <b>-40°C to 121°C (-40°F to 249°F)</b></li> </ul>                            |
| <b>Interchange Data:</b> | <ul style="list-style-type: none"> <li>High pressure screw-together interchange</li> <li>Parker/Pioneer 3000 Series, Stucchi IVHP</li> <li>Hansen WS56000, Snap-Tite 76-Series, DNP PVM</li> <li>RYCO R100 Series</li> </ul>  |

Size (inch)	Steel Ball Coupler / Plug Coupled				316 SS Ball Coupler / Plug Coupled				Steel Poppet Coupler / Plug Coupled				316 SS Poppet Coupler / Plug Coupled			
	Working Pressure		Burst Pressure		Working Pressure		Burst Pressure		Working Pressure		Burst Pressure		Working Pressure		Burst Pressure	
	PSI	Bar	PSI	Bar	PSI	Bar	PSI	Bar	PSI	Bar	PSI	Bar	PSI	Bar	PSI	Bar
1/4	10,000	700	34,300	2350	-	-	-	-	-	-	-	-	-	-	-	-
3/8	10,000	700	30,000	2050	10,000	700	30,900	2100	10,000	700	36,800	2500	10,000	700	36,500	2500

Interchange Standards					Functional Parameters				
Size (inch)	US Military	US Government	International Standards	ANSI / NFPA Standards	Valve Style	Air Inclusion	Fluid Loss	Vacuum inch HG	Flow (Lpm) ΔP = 60 PSI
1/4	-	-	ISO 14540	-	Ball	0.97	0.56	N/R	14
3/8	-	-	ISO 14540	-	Ball	2.04	0.98	N/R	16
3/8	-	-	ISO 14540	-	Poppet	1.56	0.77	N/R	22

T-Series Interchange						
Size (inch)	Parker / Pioneer	Stucchi	Holmbury	Enerpac™ - C604	Snap-Tite	Hansen
1/4	Series 3000	IVHP	HPA Series	-	76 Series	WS 5600
3/8	Series 3000	IVHP	HPA Series	-	76 Series	WS 5600

## T-Series Couplers

Size (inch)	Part No.	Thread Size (inch)	Body Material	Weight (kg)	Pkg Qty	
					Bag	Box
1/4	2TM2	1/4 - 18 NPTF	Steel	0.11	5	50
3/8	3TM3	3/8 - 18 NPTF	Steel	0.22	5	25
3/8	3TBM3	1.9 TPI	Steel	0.22	5	25
3/8	3TM3-SS	3/8 - 18 NPTF	316 SS	0.22	5	25

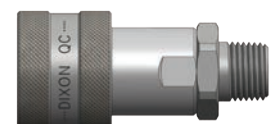

Male Thread

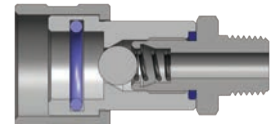

Female Thread

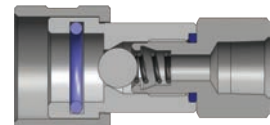

Size (inch)	Part No.	Thread Size (inch)	Body Material	Weight (kg)	Pkg Qty	
					Bag	Box
3/8	3TF3	3/8 - 18 NPTF	Steel	0.22	5	25

- ORB thread styles also available.
- A complete range of seal options are available

# Hydraulic & Pneumatic

## T-Series Poppet Couplers



Male Thread

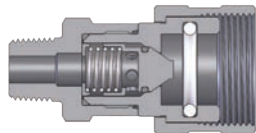

Size (inch)	Part No.	Thread Size (inch)	Body Material	Weight (kg)	Pkg Qty	
					Bag	Box
3/8	3TM3-PV	3/8 - 18 NPT	Steel	0.22	5	50
3/8	3TM3-SS-PV	3/8 - 18 NPT	316 SS	0.23	5	25

## T-Series Nipples



Female Thread

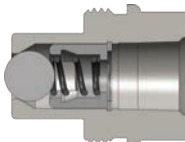

Size (inch)	Part No.	Thread Size (inch)	Body Material	Weight (kg)	Pkg Qty	
					Bag	Box
1/4	T2F2	1/4 - 18 NPTF	Steel	0.06	5	50
3/8	T3F3	3/8 - 18 NPTF	Steel	0.10	5	25
3/8	T3BF3	3/8 - 18 FBSP	Steel	0.03	-	10
3/8	T3F3-SS	3/8 - 18 NPT	316 SS	0.10	5	25

## T-Series Poppet Nipples

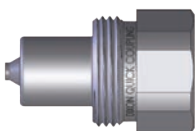

Female Thread

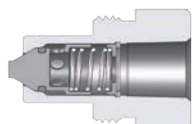

Size (inch)	Part No.	Thread Size (inch)	Body Material	Weight (kg)	Pkg Qty	
					Bag	Box
3/8	T3F3-PV	3/8 - 18 NPT	Steel	0.10	5	25
3/8	T3F3-SS-PV	3/8 - 18 NPT	316 SS	0.10	5	25

## T-Series Coupler Dust Plugs



Size (inch)	Part No.	Cap Lanyard	Body Material	Weight (kg)	Pkg Qty	
					Bag	Box
1/4	2TDP	Rubber	Steel	0.04	5	50
3/8	3TDP	Rubber	Steel	0.07	5	25

## T-Series Nipple Dust Caps



Size (inch)	Part No.	Cap Lanyard	Body Material	Weight (kg)	Pkg Qty	
					Bag	Box
1/4	T2DC	SS Bead Chain	Steel	0.05	5	50
3/8	T3DC	SS Bead Chain	Steel	0.08	5	25

## T-Series High Pressure Interchange Seal Kits

### T-Series High Pressure Enerpac™ Interchange Coupler Seal Kits

Size (inch)	Part No.	Coupler Style	Seal Material	Seal Kits Contents	Pkg Qty	
					Bag	Box
1/4	2T-SKIT	Ball Valve	Urethane	Body Seal	25	200
3/8	3T-SKIT	Ball Valve	Urethane	Body Seal	25	200

- ORB thread styles also available.
- A complete range of seal options are available

FOR TECHNICAL GUIDELINES PLEASE REFER TO PAGE 233

## TR-Series TEMA Interchange

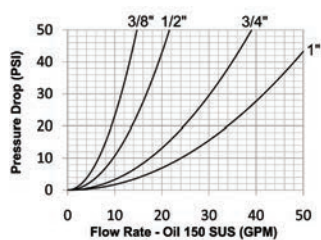

**Materials:**

- Machined components are manufactured using solid steel bar stock
- Stainless steel balls, retaining rings, and springs maximise corrosion resistance and extend service life
- Steel componentry is plated using ROHS-compliant trivalent chrome
- Steel coupler sleeves are hardened to resist deformation and maximise service life
- Steel nipples are hardened to provide heavy-duty performance

Size (inch)	Steel Coupler / Plug (Connected)			
	Working Pressure		Burst Pressure	
	PSI	Bar	PSI	Bar
1/4	4,351	300	17,400	1200
3/8	5,000	345	20,000	1400
1/2	4,000	275	16,500	1100
3/4	4,000	275	15,400	1000
1	3,200	220	12,800	900

Interchange Standards					Functional Parameters				
Size (inch)	US Military	US Government	International Standards	ANSI / NFPA Standards	Locking Ball Qty	Air Inclusion	Fluid Loss	Vacuum inch HG	Flow (Lpm) ΔP = 22 PSI
3/8	-	-	-	-	9	2.8cc	1.9cc	28	38
1/2	-	-	-	-	9	3.9cc	3.1cc	28	57
3/4	-	-	-	-	9	10.5cc	10.1cc	28	98
1	-	-	-	-	9	14.7cc	14.2cc	28	136

## TR-Series Profiles

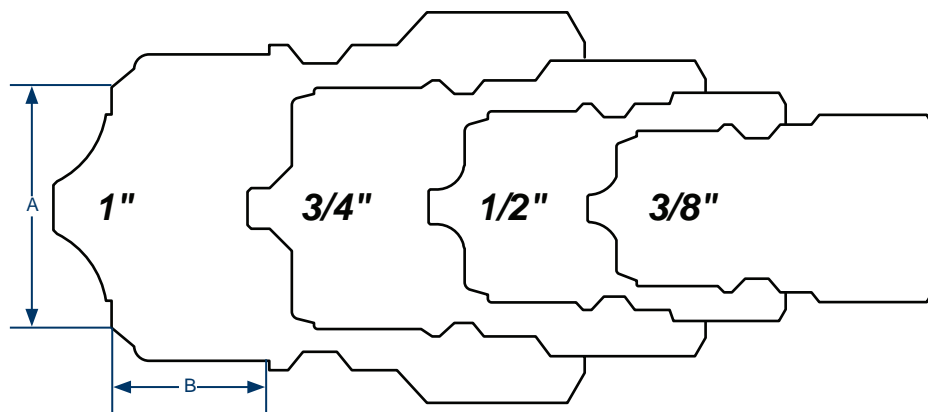

Size (inch)	A (mm)	B (mm)
1/4	15.88	11.11
3/8	19.05	14.29



## TR-Series TEMA Interchange Couplers

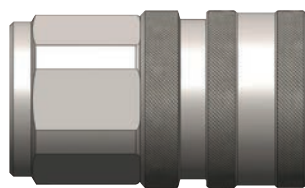

Female Thread

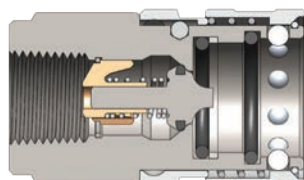

Size (inch)	Part No.	Thread Size (inch)	Body Material	Weight (kg)	Pkg Qty	
					Bag	Box
1/4	2TRBF2	1/4 - 19 BSPP	Steel	0.18	10	50
1/4	2TRBF2-E	1/4 - 19 BSPP	Steel	0.18	10	50
1/4	2TRBF2-E-SS	1/4 - 19 BSPP	316 SS	0.18	10	50
1/4	2TRBF2-V	1/4 - 19 BSPP	Steel	0.18	10	50
1/4	2TRBF2-V-SS	1/4 - 19 BSPP	316 SS	0.18	10	50
3/8	3TRBF3	3/8 - 19 BSPP	Steel	0.23	10	50
3/8	3TRBF3-E	3/8 - 19 BSPP	Steel	0.23	10	50
3/8	3TRBF3-E-SS	3/8 - 19 BSPP	316 SS	0.23	10	50
3/8	3TRBF3-V	3/8 - 19 BSPP	Steel	0.23	10	50
3/8	3TRBF3-V-SS	3/8 - 19 BSPP	316 SS	0.23	10	50
3/8	3TRBF3-PR	3/8 - 19 BSPP	Steel	0.23	10	50
1/2	4TRBF4	1/2 - 14 BSPP	Steel	0.36	5	25
1/2	4TRBF4-E	1/2 - 14 BSPP	Steel	0.36	5	25
1/2	4TRBF4-E-SS	1/2 - 14 BSPP	316 SS	0.36	5	25
1/2	4TRBF4-V-SS	1/2 - 14 BSPP	316 SS	0.36	5	25
1/2	4TRBF4-PR	1/2 - 14 BSPP	Steel	0.36	5	25
3/4	6TRBF6	3/4 - 14 BSPP	Steel	0.64	-	10
3/4	6TRBF6-E	3/4 - 14 BSPP	Steel	0.64	-	10
3/4	6TRBF6-E-SS	3/4 - 14 BSPP	316 SS	0.64	-	10
3/4	6TRBF6-V	3/4 - 14 BSPP	Steel	0.64	-	10
3/4	6TRBF6-V-SS	3/4 - 14 BSPP	316 SS	0.64	-	10
3/4	6TRBF6-PR	3/4 - 14 BSPP	Steel	0.64	-	10
1	8TRBF8	1 - 11 BSPP	Steel	0.88	-	10
1	8TRBF8-E	1 - 11 BSPP	Steel	0.88	-	10
1	8TRBF8-E-SS	1 - 11 BSPP	316 SS	0.88	-	10
1	8TRBF8-V	1 - 11 BSPP	Steel	0.88	-	10
1	8TRBF8-V-SS	1 - 11 BSPP	316 SS	0.88	-	10
1	8TRBF8-PR	1 - 11 BSPP	Steel	0.88	-	10

## TR-Series TEMA Interchange Nipples

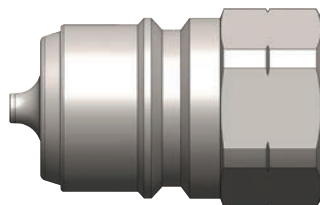

Female Thread

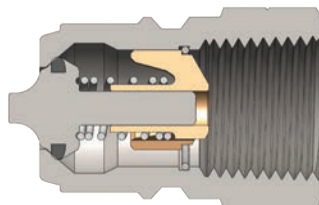

Size (inch)	Part No.	Thread Size (inch)	Body Material	Weight (kg)	Pkg Qty	
					Bag	Box
1/4	TR2BF2	1/4 - 19 BSPP	Steel	0.05	10	50
1/4	TR2BF2-E	1/4 - 19 BSPP	Steel	0.05	10	50
1/4	TR2BF2-E-SS	1/4 - 19 BSPP	316 SS	0.05	10	50
1/4	TR2BF2-V	1/4 - 19 BSPP	Steel	0.05	10	50
1/4	TR2BF2-V-SS	1/4 - 19 BSPP	316 SS	0.05	10	50
3/8	TR3BF3	3/8 - 19 BSPP	Steel	0.07	10	50
3/8	TR3BF3-E	3/8 - 19 BSPP	Steel	0.07	10	50
3/8	TR3BF3-E-SS	3/8 - 19 BSPP	316 SS	0.07	10	50
3/8	TR3BF3-V	3/8 - 19 BSPP	Steel	0.07	10	50
3/8	TR3BF3-V-SS	3/8 - 19 BSPP	316 SS	0.07	10	50
3/8	TR3BF3-PR	3/8 - 19 BSPP	Steel	0.07	10	50
1/2	TR4BF4	1/2 - 14 BSPP	Steel	0.12	5	25
1/2	TR4BF4-E	1/2 - 14 BSPP	Steel	0.12	5	25
1/2	TR4BF4-E-SS	1/2 - 14 BSPP	316 SS	0.12	5	25
1/2	TR4BF4-V	1/2 - 14 BSPP	Steel	0.12	5	25
1/2	TR4BF4-V-SS	1/2 - 14 BSPP	316 SS	0.12	5	25
1/2	TR4BF4-PR	1/2 - 14 BSPP	Steel	0.12	5	25
3/4	TR6BF6	3/4 - 14 BSPP	Steel	0.21	-	10
3/4	TR6BF6-E	3/4 - 14 BSPP	Steel	0.21	-	10
3/4	TR6BF6-E-SS	3/4 - 14 BSPP	316 SS	0.21	-	10
3/4	TR6BF6-V	3/4 - 14 BSPP	Steel	0.21	-	10
3/4	TR6BF6-V-SS	3/4 - 14 BSPP	316 SS	0.21	-	10
3/4	TR6BF6-PR	3/4 - 14 BSPP	Steel	0.21	-	10
1	TR8BF8	1 - 11 BSPP	Steel	0.36	-	10
1	TR8BF8-E	1 - 11 BSPP	Steel	0.36	-	10
1	TR8BF8-E-SS	1 - 11 BSPP	316 SS	0.36	-	10
1	TR8BF8-V	1 - 11 BSPP	Steel	0.36	-	10
1	TR8BF8-V-SS	1 - 11 BSPP	316 SS	0.36	-	10
1	TR8BF8-PR	1 - 11 BSPP	Steel	0.36	-	10

FOR TECHNICAL GUIDELINES PLEASE REFER TO PAGE 235

## TR-Series TEMA Interchange Coupler Seal Kits

Size (inch)	Part No.	Coupler Style	Seal Material	Seal Kits Contents	Pkg Qty
¼	2TR-SKIT	All	Nitrile	Two O-rings	1
¼	2TR-VSKIT	All	FKM	Two O-rings	1
¾	3TR-SKIT	All	Nitrile	Two O-rings	1
½	4TR-SKIT	All	Nitrile	Two O-rings	1
½	4TR-VSKIT	All	FKM	Two O-rings	1
¾	6TR-SKIT	All	Nitrile	Two O-rings	1
¾	6TR-VSKIT	All	FKM	Two O-rings	1
1	8TR-SKIT	All	Nitrile	Two O-rings	1
1	8TR-VSKIT	All	FKM	Two O-rings	1

## TR-Series TEMA Interchange Dust Plugs

Size (inch)	Part No.	Body Material	Weight (kg)	Bag Qty
¼	2TRDP	Elastomer	0.01	10
¾	3TRDP	Elastomer	0.02	10
½	4TRDP	Elastomer	0.03	10
¾	6TRDP	Elastomer	0.03	10
1	8TRDP	Elastomer	0.05	10



## TR-Series TEMA Interchange Dust Caps

Size (inch)	Part No.	Body Material	Weight (kg)	Bag Qty
¼	TR2DC	Elastomer	0.01	10
¾	TR3DC	Elastomer	0.02	10
½	TR4DC	Elastomer	0.03	10
¾	TR6DC	Elastomer	0.03	10
1	TR8DC	Elastomer	0.05	10



E

FOR TECHNICAL GUIDELINES PLEASE REFER TO PAGE 235

# Hydraulic & Pneumatic

## E-Series Straight-Through Pressure-Wash Interchange

<b>Materials:</b>	<ul style="list-style-type: none"> <li>Machined components are manufactured using solid steel, brass, or 316 stainless steel bar stock</li> <li>Stainless steel balls, retaining rings, and springs maximise corrosion resistance and extend service life</li> <li>Steel componentry is plated using ROHS-compliant trivalent chrome</li> <li>1 1/4" to 2" brass couplers have steel sleeves as standard to maximise service life; hardened to resist deformation</li> <li>Steel nipples are hardened to provide heavy-duty performance</li> </ul>
<b>Seal Components:</b>	<ul style="list-style-type: none"> <li>Nitrile (Buna-N) seals are standard, providing a temperature range of <b>-40°C to 121°C (-40°F to 249°F)</b></li> </ul>
<b>Interchange Data:</b>	<ul style="list-style-type: none"> <li>Straight-through pressure-wash interchange</li> <li>Parker ST-Series, Foster FST-Series, Tomco Series-ST, Hansen ST-Series</li> </ul>

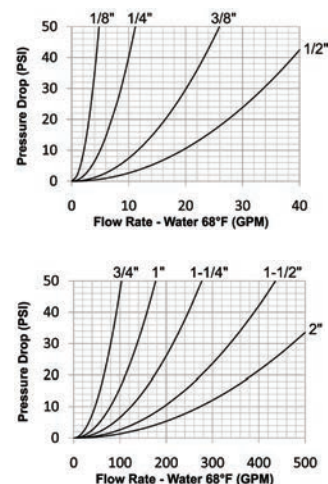

Size (inch)	Brass Coupler / Steel Plug Coupled				Brass Coupler / Plug Coupled				Brass Coupler / 303 SS Plug Coupled				303 SS Coupler / Plug Coupled			
	Working Pressure		Burst Pressure		Working Pressure		Burst Pressure		Working Pressure		Burst Pressure		Working Pressure		Burst Pressure	
	PSI	Bar	PSI	Bar	PSI	Bar	PSI	Bar	PSI	Bar	PSI	Bar	PSI	Bar	PSI	Bar
1/8"	2,600	179	10,400	717	2,500	172	10,000	689	4,200	290	16,800	1,158	5,000	345	29,900	2,062
1/4"	5,500	379	22,000	1,517	5,200	359	20,800	1,434	6,700	462	26,800	1,848	7,500	517	33,800	2,331
3/8"	3,500	241	14,000	966	2,700	186	10,800	745	5,500	379	22,000	1,517	7,500	517	34,400	2,372
1/2"	2,700	186	10,800	745	2,200	152	8,800	607	3,000	207	12,000	827	3,500	241	14,000	966
3/4"	2,700	186	10,800	745	1,700	117	6,800	469	3,000	207	12,000	827	3,000	207	19,400	1,338
1"	2,000	138	8,000	552	1,200	83	4,800	331	1,700	117	6,800	469	2,000	138	9,100	628
1-1/4"	2,000	138	8,000	552	1,700	117	6,800	469	2,000	138	8,000	552	2,000	138	10,000	690
1-1/2"	2,000	138	8,000	552	1,400	97	5,600	386	2,000	138	8,000	552	2,000	138	12,000	828
2"	2,000	138	8,000	552	1,400	97	5,600	386	2,000	138	8,000	552	2,000	138	9,000	621

E

Size (inch)	Interchange Standards				Functional Parameters					
	US Military	US Government	International Standards	ANSI / NFPA Standards	Locking Ball Qty	Air Inclusion	Fluid Loss	Vacuum inch HG	Flow (Lpm) ΔP = 15 PSI	
1/8"	-	-	-	-	8	N/A	N/A	N/R	11	
1/4"	-	-	-	-	8	N/A	N/A	N/R	22	
3/8"	-	-	-	-	8	N/A	N/A	N/R	53	
1/2"	-	-	-	-	8	N/A	N/A	N/R	91	
3/4"	-	-	-	-	8	N/A	N/A	N/R	249	
1"	-	-	-	-	8	N/A	N/A	N/R	378	
1 1/4"	-	-	-	-	8	N/A	N/A	N/R	567	
1 1/2"	-	-	-	-	8	N/A	N/A	N/R	946	
2"	-	-	-	-	8	N/A	N/A	N/R	1235	

T-Series Interchange				
Size (inch)	Parker / Pioneer	Foster	Tomco	Hansen
1/8"	ST-Series	FST-Series	Series-ST	ST-Series
1/4"	ST-Series	FST-Series	Series-ST	ST-Series
3/8"	ST-Series	FST-Series	Series-ST	ST-Series
1/2"	ST-Series	FST-Series	Series-ST	ST-Series
3/4"	ST-Series	FST-Series	Series-ST	ST-Series
1"	ST-Series	FST-Series	Series-ST	ST-Series
1 1/4"	ST-Series	FST-Series	Series-ST	ST-Series
1 1/2"	ST-Series	FST-Series	Series-ST	ST-Series
2"	ST-Series	FST-Series	Series-ST	ST-Series





**E-Series Straight-Through Couplers**

Size (inch)	Part No.	Thread Size (inch)	Body Material	Weight (kg)	Pkg Qty	
					Bag	Box
¼	1EF1-B	¼ - 27 NPTF	Brass	0.03	250	500
¼	1EF1-S	¼ - 27 NPTF	303 SS	0.02	250	500
¼	2EF2-B	¼ - 18 NPTF	Brass	0.08	50	200
¼	2EF2-S	¼ - 18 NPTF	303 SS	0.07	50	200
¼	2EBF2-B	¼ - 19 BSPP	Brass	0.08	50	200
¾	3EF3-B	¾ - 18 NPTF	Brass	0.12	50	200
¾	3EF3-S	¾ - 18 NPTF	303 SS	0.11	50	200
¾	3EBF3-B	¾ - 19 BSPP	Brass	0.12	50	200
½	4EF4-B	½ - 14 NPTF	Brass	0.18	25	100
½	4EF4-S	½ - 14 NPTF	303 SS	0.16	25	100
½	4EBF4-B	½ - 14 BSPP	Brass	0.18	25	100
¾	6EF6-B	¾ - 14 NPTF	Brass	0.28	15	60
¾	6EF6-S	¾ - 14 NPTF	303 SS	0.26	15	60
¾	6EBF6-B	¾ - 14 BSPP	Brass	0.28	15	60
1	8EF8-B	1 - 11½ NPTF	Brass	0.45	15	30
1	8EF8-S	1 - 11½ NPTF	303 SS	0.42	15	30
1	8EBF8-B	1 - 11 BSPP	Brass	0.45	15	30
1¼	10EF10-B	1¼ - 11½ NPTF	Brass	0.63	-	10
1¼	10EF10-S	1¼ - 11½ NPTF	303 SS	0.63	-	10
1½	12EF12-B	1½ - 11½ NPTF	Brass	0.64	-	5
1½	12EF12-S	1½ - 11½ NPTF	303 SS	0.64	-	5
2	16EF16-B	2 - 11½ NPTF	Brass	2.13	-	1
2	16EF16-S	2 - 11½ NPTF	303 SS	2.13	-	1



Female Thread

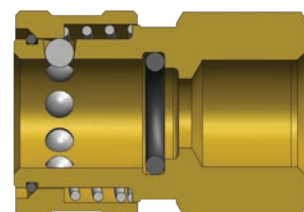

E

FOR TECHNICAL GUIDELINES PLEASE REFER TO PAGE 238

## E-Series Straight-Through Nipples

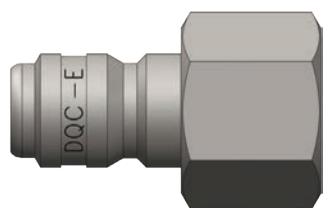

Female Thread

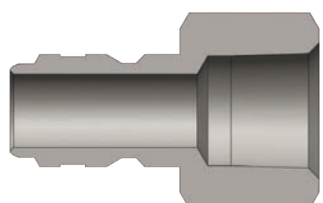

Size (inch)	Part No.	Thread Size (inch)	Body Material	Weight (kg)	Pkg Qty	
					Bag	Box
1/8	E1F1	1/8 - 27 NPTF	Steel	0.01	250	500
1/8	E1F1-B	1/8 - 27 NPTF	Brass	0.01	250	500
1/8	E1F1-S	1/8 - 27 NPTF	303 SS	0.01	250	500
1/4	E2F2	1/4 - 18 NPTF	Steel	0.03	50	200
1/4	E2F2-B	1/4 - 18 NPTF	Brass	0.03	50	200
1/4	E2F2-S	1/4 - 18 NPTF	303 SS	0.03	50	200
1/4	E2BF2-B	1/4 - 19 BSPP	Brass	0.03	50	200
3/8	E3F3	3/8 - 18 NPTF	Steel	0.05	50	200
3/8	E3F3-B	3/8 - 18 NPTF	Brass	0.05	50	200
3/8	E3F3-S	3/8 - 18 NPTF	303 SS	0.05	50	200
3/8	E3BF3-B	3/8 - 19 BSPP	Brass	0.05	50	200
1/2	E4F4	1/2 - 14 NPTF	Steel	0.09	35	140
1/2	E4F4-B	1/2 - 14 NPTF	Brass	0.10	35	140
1/2	E4F4-S	1/2 - 14 NPTF	303 SS	0.10	35	140
1/2	E4BF4-B	1/2 - 14 BSPP	Brass	0.10	35	140
3/4	E6F6	3/4 - 14 NPTF	Steel	0.14	25	100
3/4	E6F6-B	3/4 - 14 NPTF	Brass	0.14	25	100
3/4	E6F6-S	3/4 - 14 NPTF	303 SS	0.14	25	100
3/4	E6BF6-B	3/4 - 14 BSPP	Brass	0.14	25	100
1	E8F8	1 - 11 1/2 NPTF	Steel	0.22	25	50
1	E8F8-B	1 - 11 1/2 NPTF	Brass	0.23	25	50
1	E8F8-S	1 - 11 1/2 NPTF	303 SS	0.23	25	50
1	E8BF8-B	1 - 11 BSPP	Brass	0.22	25	50
1 1/4	E10F10	1 1/4 - 11 1/2 NPTF	Steel	0.38	-	10
1 1/4	E10F10-B	1 1/4 - 11 1/2 NPTF	Brass	0.38	-	10
1 1/4	E10F10-S	1 1/4 - 11 1/2 NPTF	303 SS	0.38	-	10
1 1/2	E12F12	1 1/2 - 11 1/2 NPTF	Steel	0.65	-	5
1 1/2	E12F12-B	1 1/2 - 11 1/2 NPTF	Brass	0.66	-	5
1 1/2	E12F12-S	1 1/2 - 11 1/2 NPTF	303 SS	0.66	-	5
2	E16F16	2 - 11 1/2 NPTF	Steel	0.86	-	1
2	E16F16-B	2 - 11 1/2 NPTF	Brass	0.86	-	1
2	E16F16-S	2 - 11 1/2 NPTF	303 SS	0.86	-	1

E

## E-Series Profiles

Size (inch)	A (mm)	B (mm)
1/8	7.94	2.38
1/4	9.53	3.18
3/8	12.70	3.18
1/2	15.88	3.18
3/4	22.22	4.76
1	30.16	4.76
1 1/4	36.51	3.18
1 1/2	44.45	4.76
2	58.74	4.76

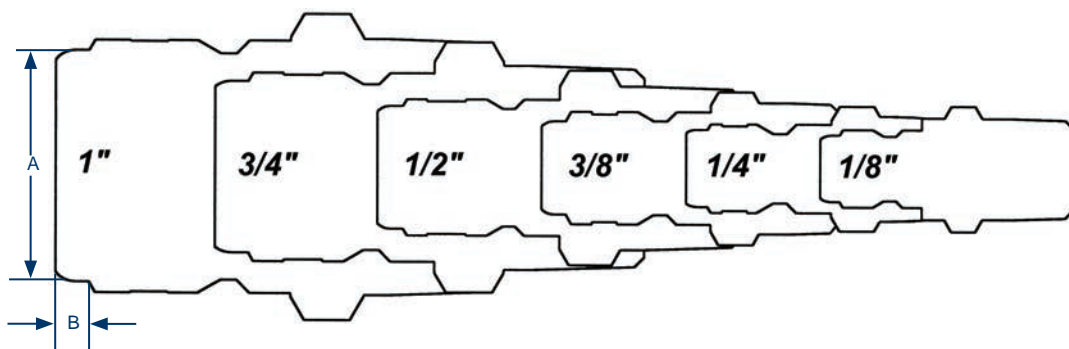

FOR TECHNICAL GUIDELINES PLEASE REFER TO PAGE 238

## E-Series Straight-Through Couplers

Size (inch)	Part No.	Thread Size (inch)	Body Material	Weight (kg)	Pkg Qty	
					Bag	Box
¼	1EM1-B	¼ - 27 NPTF	Brass	0.03	250	500
¼	1EM1-S	¼ - 27 NPTF	303 SS	0.02	250	500
¼	2EM2-B	¼ - 18 NPTF	Brass	0.08	50	200
¾	3EM3-B	¾ - 18 NPTF	Brass	0.12	50	200
¾	3EM3-S	¾ - 18 NPTF	303 SS	0.11	50	200
½	4EM4-B	½ - 14 NPTF	Brass	0.18	25	100
½	4EM4-S	½ - 14 NPTF	303 SS	0.16	25	100
¾	6EM6-B	¾ - 14 NPTF	Brass	0.28	15	60
¾	6EM6-S	¾ - 14 NPTF	303 SS	0.26	15	60
1	8EM8-B	1 - 11½ NPTF	Brass	0.45	15	30
1	8EM8-S	1 - 11½ NPTF	303 SS	0.42	15	30
1¼	10EM10-B	1¼ - 11½ NPTF	Brass	0.74	-	10
1½	12EM12-B	1½ - 11½ NPTF	Brass	0.93	-	5
2	16EM16-B	2 - 11½ NPTF	Brass	1.43	-	1



Male Thread

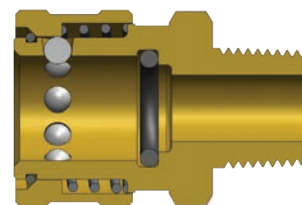

## E-Series Straight-Through Nipples

Size (inch)	Part No.	Thread Size (inch)	Body Material	Weight (kg)	Pkg Qty	
					Bag	Box
¼	E1M1	¼ - 27 NPTF	Steel	0.01	250	500
¼	E1M1-B	¼ - 27 NPTF	Brass	0.01	250	500
¼	E1M1-S	¼ - 27 NPTF	303 SS	0.01	250	500
¼	E2M2	¼ - 18 NPTF	Steel	0.02	50	200
¼	E2M2-B	¼ - 18 NPTF	Brass	0.03	50	200
¼	E2M2-S	¼ - 18 NPTF	303 SS	0.02	50	200
¾	E3M3	¾ - 18 NPTF	Steel	0.03	50	200
¾	E3M3-B	¾ - 18 NPTF	Brass	0.04	50	200
¾	E3M3-S	¾ - 18 NPTF	303 SS	0.04	50	200
½	E4M4	½ - 14 NPTF	Steel	0.06	35	140
½	E4M4-B	½ - 14 NPTF	Brass	0.07	35	140
½	E4M4-S	½ - 14 NPTF	303 SS	0.06	35	140
¾	E6M6	¾ - 14 NPTF	Steel	0.09	25	100
¾	E6M6-B	¾ - 14 NPTF	Brass	0.10	25	100
¾	E6M6-S	¾ - 14 NPTF	303 SS	0.10	25	100
1	E8M8	1 - 11½ NPTF	Steel	0.20	25	50
1	E8M8-B	1 - 11½ NPTF	Brass	0.22	25	50
1	E8M8-S	1 - 11½ NPTF	303 SS	0.20	25	50
1¼	E10M10	1¼ - 11½ NPTF	Steel	0.43	-	10
1¼	E10M10-B	1¼ - 11½ NPTF	Brass	0.43	-	10
1½	E12M12	1½ - 11½ NPTF	Steel	0.66	-	5
1½	E12M12-B	1½ - 11½ NPTF	Brass	0.66	-	5
2	E16M16	2 - 11½ NPTF	Steel	0.70	-	1
2	E16M16-B	2 - 11½ NPTF	Brass	0.68	-	1

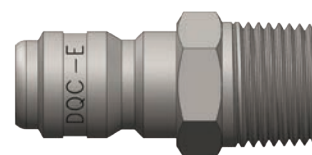

Male Thread

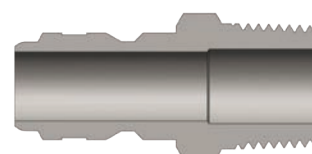

E

FOR TECHNICAL GUIDELINES PLEASE REFER TO PAGE 238

## E-Series Straight-Through Couplers

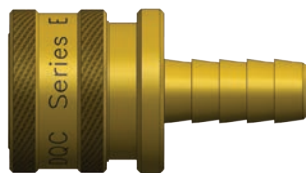

Hose Barb

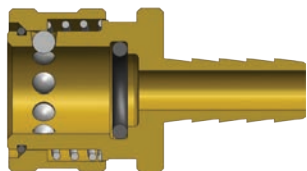

Size (inch)	Part No.	Hose ID (inch)	Body Material	Weight (kg)	Pkg Qty	
					Bag	Box
¼	2ES2-B	¼	Brass	0.07	50	200
⅜	3ES3-B	⅜	Brass	0.09	50	200
½	4ES4-B	½	Brass	0.14	25	100
¾	6ES6-B	¾	Brass	0.20	15	60
1	8ES8-B	1	Brass	0.30	15	30

## E-Series Straight-Through Nipples

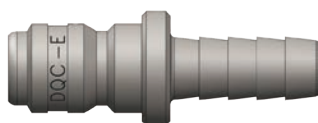

Hose Barb

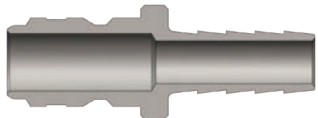

Size (inch)	Part No.	Hose ID (inch)	Body Material	Weight (kg)	Pkg Qty	
					Bag	Box
¼	E2S2	¼	Steel	0.02	50	200
¼	E2S2-B	¼	Brass	0.03	50	200
⅜	E3S3	⅜	Steel	0.04	50	200
⅜	E3S3-B	⅜	Brass	0.04	50	200
½	E4S4	½	Steel	0.06	35	140
½	E4S4-B	½	Brass	0.06	35	140
¾	E6S6	¾	Steel	0.09	25	100
¾	E6S6-B	¾	Brass	0.09	25	100
1	E8S8	1	Steel	0.20	25	50
1	E8S8-B	1	Brass	0.20	25	50

## E-Series Straight-Through Coupler Seal Kits

Size (inch)	Part No.	Coupler Style	Seal Material	Seal Kits Contents	Pkg Qty	
					Bag	Box
¼	2E-SKIT	all	Nitrile	Body O-ring	25	200
¼	F-2E-SKIT	all	FKM	Body O-ring	25	200
¼	P-2E-SKIT	all	EPDM	Body O-ring	25	200
⅜	3E-SKIT	all	Nitrile	Body O-ring	25	200
⅜	F-3E-SKIT	all	FKM	Body O-ring	25	200
⅜	P-3E-SKIT	all	EPDM	Body O-ring	25	200
½	4E-SKIT	all	Nitrile	Body O-ring	25	200
½	F-4E-SKIT	all	FKM	Body O-ring	25	200
½	P-4E-SKIT	all	EPDM	Body O-ring	25	200
¾	6E-SKIT	all	Nitrile	Body O-ring	25	200
¾	F-6E-SKIT	all	FKM	Body O-ring	25	200
¾	P-6E-SKIT	all	EPDM	Body O-ring	25	200
1	8E-SKIT	all	Nitrile	Body O-ring	25	200
1	F-8E-SKIT	all	FKM	Body O-ring	25	200
1	P-8E-SKIT	all	EPDM	Body O-ring	25	200
1¼	10E-SKIT	all	Nitrile	Body O-ring	25	-
1¼	F-10E-SKIT	all	FKM	Body O-ring	25	-
1¼	P-10E-SKIT	all	EPDM	Body O-ring	25	-
1½	12E-SKIT	all	Nitrile	Body O-ring	25	-
1½	F-12E-SKIT	all	FKM	Body O-ring	25	-
1½	P-12E-SKIT	all	EPDM	Body O-ring	25	-
2	16E-SKIT	all	Nitrile	Body O-ring	25	-
2	F-16E-SKIT	all	FKM	Body O-ring	25	-
2	P-16E-SKIT	all	EPDM	Body O-ring	25	-

FOR TECHNICAL GUIDELINES PLEASE REFER TO PAGE 238

## V-Series Snap-Tite H/H Interchange

<b>Materials:</b>	<ul style="list-style-type: none"> <li>Machined components are manufactured using solid steel, brass, or 316 stainless steel bar stock</li> <li>Stainless steel balls, retaining rings, and springs maximise corrosion resistance and extend service life</li> <li>Steel componentry is plated using ROHS-compliant trivalent chrome</li> <li>Steel coupler sleeves are hardened to resist deformation and maximise service life</li> <li>Steel nipples are machined from high-strength steel and induction hardened</li> <li>Tubular (TV) valves are constructed from steel bar stock and are designed for optimum performance in pneumatic applications</li> </ul>
<b>Seal Components:</b>	<ul style="list-style-type: none"> <li>Nitrile (Buna-N) seals are standard, providing a temperature range of <b>-40°C to 121°C (-40°F to 249°F)</b></li> <li>All couplers incorporate a PTFE anti-extrusion ring to protect the seal components from dynamic impulse damage</li> <li>¼" to 1" valve seals are crimped in place to maintain integrity during excessive flow conditions and pressurised connection</li> <li>1¼" to 2" valve O-rings are retained by a unique seal-groove profile and are field replaceable</li> </ul>
<b>Interchange Data:</b>	<ul style="list-style-type: none"> <li>Interchangeable to MIL-C-51234</li> <li>Snap-Tite H/H and Faster TNV/TNL</li> </ul>

Note: Air flow data is presented using a coupler with a TV valve and unvalved nipple. This configuration provides the optimal performance for pneumatic applications.

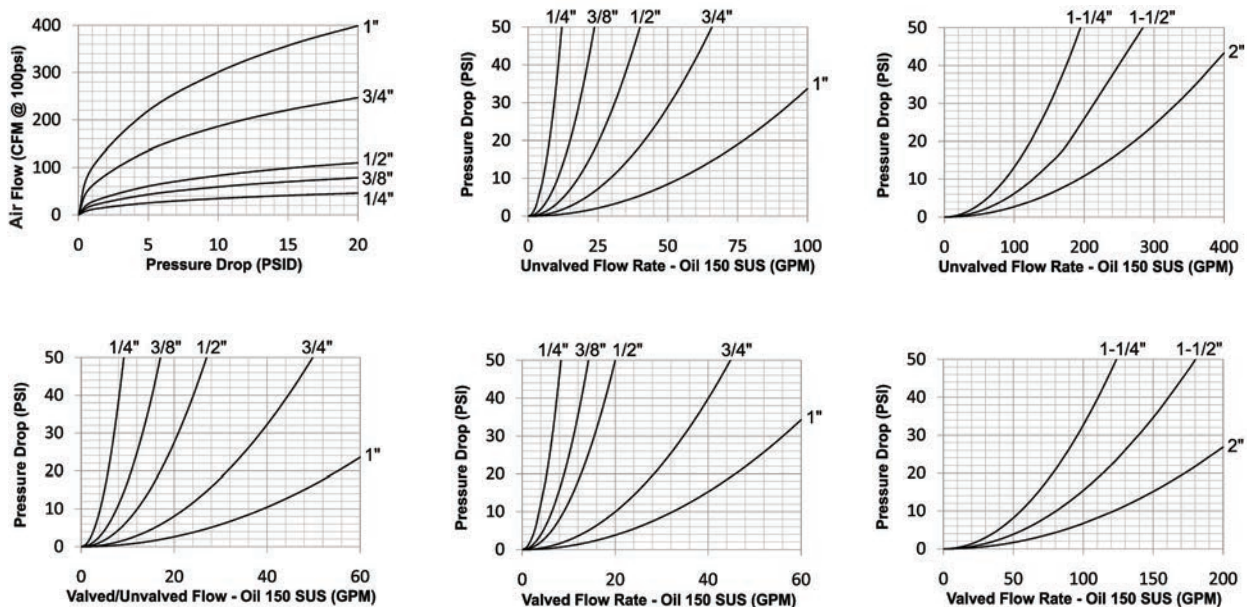

## V-Series Profiles

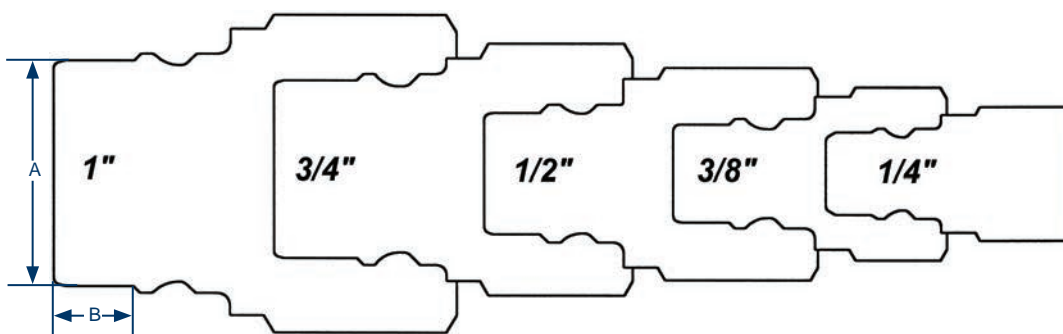

Size (inch)	A (mm)	B (mm)
¼	11.11	6.35
⅜	12.70	7.14
½	15.88	7.93
¾	23.81	9.53
1	30.10	9.53



# Hydraulic & Pneumatic

## V-Series Snap-Tite H/H Interchange

Size (inch)	Steel Coupler / Plug Valved Coupled				Brass Coupler / Plug Valved Coupled				316 SS Coupler / Plug Valved Coupled			
	Working Pressure		Burst Pressure		Working Pressure		Burst Pressure		Working Pressure		Burst Pressure	
	PSI	Bar	PSI	Bar	PSI	Bar	PSI	Bar	PSI	Bar	PSI	Bar
¼	6,500	450	12,700	876	2,250	150	5,000	345	5,000	345	10,000	700
⅜	4,500	310	10,500	700	2,250	150	5,300	350	4,000	275	8,000	550
½	4,000	275	9,600	650	2,000	130	5,700	390	3,750	260	7,500	500
¾	3,500	240	9,100	600	2,000	130	5,300	350	2,000	130	7,500	500
1	2,000	130	9,500	650	1,750	120	5,000	345	2,000	130	5,000	345
1¼	1,750	120	5,000	345	350	24	1,000	70	1,500	100	3,000	200
1½	1,500	100	5,000	345	350	24	1,200	80	1,500	100	3,000	200
2	1,500	100	4,000	275	400	28	1,000	70	500	34	1,000	70

Size (inch)	Steel Coupler / Plug Unvalved Coupled				Brass Coupler / Plug Unvalved Coupled				316 SS Coupler / Plug Unvalved Coupled			
	Working Pressure		Burst Pressure		Working Pressure		Burst Pressure		Working Pressure		Burst Pressure	
	PSI	Bar	PSI	Bar	PSI	Bar	PSI	Bar	PSI	Bar	PSI	Bar
¼	11,000	760	29,500	2000	4,000	275	14,200	980	10,000	670	29,200	2000
⅜	11,000	760	29,900	2000	4,000	275	14,500	1000	8,000	550	27,900	1900
½	11,000	760	29,300	2000	4,000	275	14,500	1000	8,000	550	24,600	1700
¾	9,000	620	19,300	1300	3,500	250	11,100	750	7,000	480	22,600	1500
1	6,000	400	15,900	1100	3,000	200	8,200	560	4,000	275	15,500	1000
1¼	5,000	345	10,000	700	1,000	70	4,000	275	3,000	200	10,000	700
1½	5,000	345	10,000	700	1,000	70	4,000	275	3,000	200	10,000	700
2	4,000	275	8,000	550	750	50	2,800	190	1,000	70	6,000	400

Size (inch)	Interchange Standards			Functional Parameters				
	US Military	International Standards	ANSI / NFPA Standards	Locking Ball Qty	Air Inclusion	Fluid Loss	Vacuum inch HG	Flow (Lpm) ΔP = 22 PSI
¼	MIL-C-51234	-	-	6	2.0cc	0.2cc	26.7	21
⅜	MIL-C-51234	-	-	6	3.5cc	3.2cc	26.7	36
½	MIL-C-51234	-	-	9	4.0cc	4.0cc	26.7	49
¾	MIL-C-51234	-	-	9	14.0cc	14.0cc	26.7	113
1	MIL-C-51234	-	-	12	21.0cc	20.0cc	26.7	181
1¼	MIL-C-51234	-	-	12	45.0cc	45.0cc	N/R	310
1½	MIL-C-51234	-	-	12	80.0cc	80.0cc	N/R	454
2	MIL-C-51234	-	-	12	150.0cc	150.0cc	N/R	700

## Large V-Series Profiles

Size (inch)	A (mm)	B (mm)
1¼	15.88	12.70
1½	44.21	12.70
2	65.09	14.29

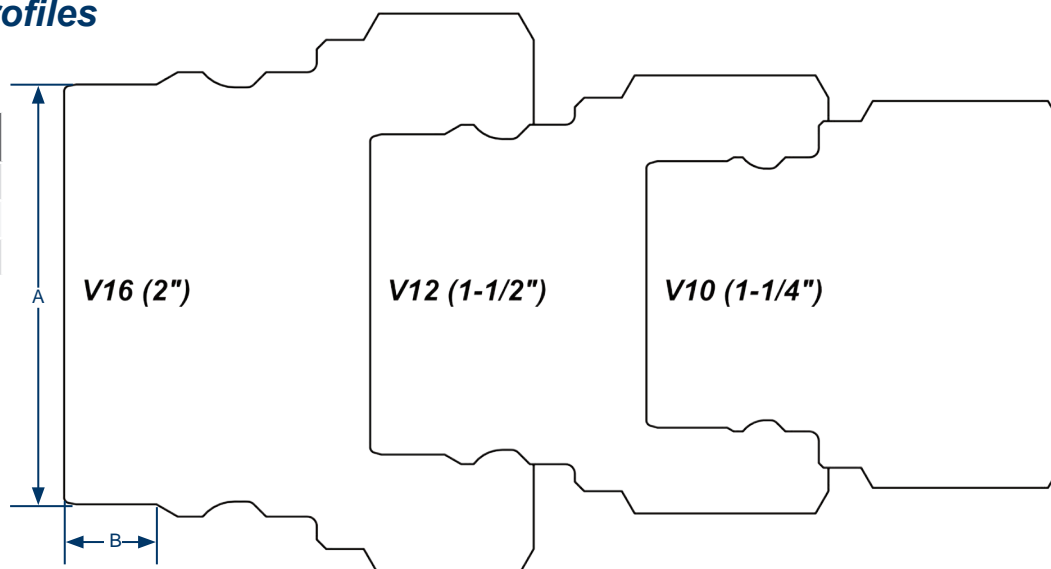

FOR TECHNICAL GUIDELINES PLEASE REFER TO PAGE 243

## V-Series Snap-Tite H/H Interchange Valved Couplers

Size (inch)	Part No.	Thread Size (inch)	Body Material	Weight (kg)	Pkg Qty	
					Bag	Box
¼	2VF1	¼ - 27 NPTF	Steel	0.10	5	50
¼	2VF2	¼ - 18 NPTF	Steel	0.09	5	50
¼	2VF2-B	¼ - 18 NPTF	Brass	0.09	5	50
¼	2VF2-SS	¼ - 18 NPTF	316 SS	0.09	5	50
¼	2VBF2	¼ - 19 BSPP	Steel	0.09	5	50
¼	2VBF2-B	¼ - 19 BSPP	Brass	0.09	5	50
¼	2VBF2-SS	¼ - 19 BSPP	316 SS	0.09	5	50
¼	2VOF2	7/16 - 20 ORB	Steel	0.10	5	50
⅜	3VF3	⅜ - 18 NPTF	Steel	0.17	5	50
⅜	3VF3-B	⅜ - 18 NPTF	Brass	0.17	5	50
⅜	3VF3-SS	⅜ - 18 NPTF	316 SS	0.17	5	50
⅜	3VBF3	⅜ - 19 BSPP	Steel	0.17	5	50
⅜	3VBF3-B	⅜ - 19 BSPP	Brass	0.17	5	50
⅜	3VBF3-SS	⅜ - 19 BSPP	316 SS	0.17	5	50
⅜	3VOF3	9/16 - 18 ORB	Steel	0.18	5	50
⅜	3VF4	½ - 14 NPTF	Steel	0.22	5	50
½	4VF4	½ - 14 NPTF	Steel	0.22	5	25
½	4VF4-B	½ - 14 NPTF	Brass	0.22	5	25
½	4VF4-SS	½ - 14 NPTF	316 SS	0.23	5	25
½	4VBF4	½ - 14 BSPP	Steel	0.22	5	25
½	4VBF4-B	½ - 14 BSPP	Brass	0.22	5	25
½	4VBF4-SS	½ - 14 BSPP	316 SS	0.23	5	25
½	4VOF4	¾ - 16 ORB	Steel	0.24	5	25
½	4VF6	¾ - 14 NPTF	Steel	0.26	5	25
¾	6VF6	¾ - 14 NPTF	Steel	0.40	5	20
¾	6VF6-B	¾ - 14 NPTF	Brass	0.40	5	20
¾	6VF6-SS	¾ - 14 NPTF	316 SS	0.43	5	20
¾	6VBF6	¾ - 14 BSPP	Steel	0.40	5	20
¾	6VBF6-B	¾ - 14 BSPP	Brass	0.40	5	20
¾	6VBF6-SS	¾ - 14 BSPP	316 SS	0.43	5	20
¾	6VOF6	1 1/16 - 12 ORB	Steel	0.45	5	20
1	8VF8	1 - 1 1/2 NPTF	Steel	0.60	-	10
1	8VF8-B	1 - 1 1/2 NPTF	Brass	0.60	-	10
1	8VF8-SS	1 - 1 1/2 NPTF	316 SS	0.60	-	10
1	8VBF8	1 - 11 BSPP	Steel	0.60	-	10
1	8VBF8-B	1 - 11 BSPP	Brass	0.60	-	10
1	8VBF8-SS	1 - 11 BSPP	316 SS	0.60	-	10
1	8VOF8	1 5/16 - 12 ORB	Steel	0.64	-	10



Female Thread

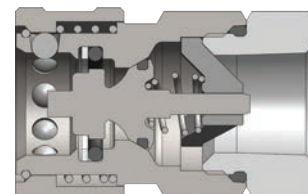

E

FOR TECHNICAL GUIDELINES PLEASE REFER TO PAGE 243

## V-Series Snap-Tite H/H Interchange Valved Nipples

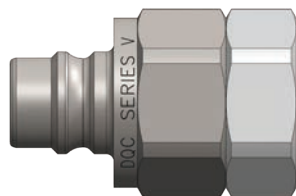

Female Thread

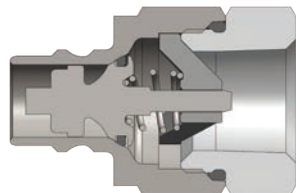

Size (inch)	Part No.	Thread Size (inch)	Body Material	Weight (kg)	Pkg Qty	
					Bag	Box
¼	V2F1	¼ - 27 NPTF	Steel	0.08	5	50
¼	V2F2	¼ - 18 NPTF	Steel	0.06	5	50
¼	V2F2-B	¼ - 18 NPTF	Brass	0.06	5	50
¼	V2F2-SS	¼ - 18 NPTF	316 SS	0.07	5	50
¼	V2BF2	¼ - 19 BSPP	Steel	0.05	5	50
¼	V2BF2-B	¼ - 19 BSPP	Brass	0.05	5	50
¼	V2BF2-SS	¼ - 19 BSPP	316 SS	0.05	5	50
¼	V2OF2	7/16 - 20 ORB	Steel	0.07	5	50
⅜	V3F3-B	⅜ - 18 NPTF	Brass	0.10	5	50
⅜	V3F3-SS	⅜ - 18 NPTF	316 SS	0.10	5	50
⅜	V3BF3	⅜ - 19 BSPP	Steel	0.10	5	50
⅜	V3BF3-B	⅜ - 19 BSPP	Brass	0.10	5	50
⅜	V3BF3-SS	⅜ - 19 BSPP	316 SS	0.10	5	50
⅜	V3OF3	9/16 - 18 ORB	Steel	0.11	5	50
⅜	V3F4	½ - 14 NPTF	Steel	0.12	5	50
½	V4F4	½ - 14 NPTF	Steel	0.14	5	25
½	V4F4-SS	½ - 14 NPTF	316 SS	0.14	5	25
½	V4BF4	½ - 14 BSPP	Steel	0.14	5	25
½	V4BF4-B	½ - 14 BSPP	Brass	0.14	5	25
½	V4BF4-SS	½ - 14 BSPP	316 SS	0.14	5	25
½	V4OF4	¾ - 16 ORB	Steel	0.15	5	25
½	V4F6	¾ - 14 NPTF	Steel	0.17	5	25
¾	V6F6	¾ - 14 NPTF	Steel	0.27	5	20
¾	V6F6-B	¾ - 14 NPTF	Brass	0.27	5	20
¾	V6F6-SS	¾ - 14 NPTF	316 SS	0.27	5	20
¾	V6BF6	¾ - 14 BSPP	Steel	0.27	5	20
¾	V6BF6-B	¾ - 14 BSPP	Brass	0.27	5	20
¾	V6BF6-SS	¾ - 14 BSPP	316 SS	0.28	5	20
¾	V6OF6	1 1/16 - 12 ORB	Steel	0.30	5	20
1	V8F8	1 - 11 ½ NPTF	Steel	0.42	-	10
1	V8F8-B	1 - 11 ½ NPTF	Brass	0.42	-	10
1	V8F8-SS	1 - 11 ½ NPTF	316 SS	0.43	-	10
1	V8BF8	1 - 11 BSPP	Steel	0.42	-	10
1	V8BF8-B	1 - 11 BSPP	Brass	0.43	-	10
1	V8BF8-SS	1 - 11 BSPP	316 SS	0.42	-	10
1	V8OF8	1 1/16 - 12 ORB	Steel	0.44	-	10

E

FOR TECHNICAL GUIDELINES PLEASE REFER TO PAGE 243



### V-Series Snap-Tite H/H Interchange Valved Couplers

Size (inch)	Part No.	Thread Size (inch)	Body Material	Weight (kg)	Pkg Qty	
					Bag	Box
1¼	10VF10	1¼ - 11½ NPTF	Steel	0.88	-	10
1¼	10VF10-B	1¼ - 11½ NPTF	Brass	0.88	-	10
1¼	10VF10-SS	1¼ - 11½ NPTF	316 SS	0.88	-	10
1¼	10VBF10	1¼ - 11 BSPP	Steel	0.88	-	10
1¼	10VBF10-B	1¼ - 11 BSPP	Brass	0.88	-	10
1¼	10VBF10-SS	1¼ - 11 BSPP	316 SS	0.88	-	10
1¼	10VOF10	1⅝ - 12 ORB	Steel	0.87	-	10
1½	12VF12	1½ - 11½ NPTF	Steel	1.33	-	5
1½	12VF12-B	1½ - 11½ NPTF	Brass	1.33	-	5
1½	12VF12-SS	1½ - 11½ NPTF	316 SS	1.33	-	5
1½	12VBF12	1½ - 11 BSPP	Steel	1.33	-	5
1½	12VBF12-B	1½ - 11 BSPP	Brass	1.33	-	5
1½	12VBF12-SS	1½ - 11 BSPP	316 SS	1.33	-	5
1½	12VOF12	1⅝ - 12 ORB	Steel	1.36	-	5
2	16VF16	2 - 11½ NPTF	Steel	2.81	-	5
2	16VF16-B	2 - 11½ NPTF	Brass	2.81	-	5
2	16VF16-SS	2 - 11½ NPTF	316 SS	2.81	-	5
2	16VBF16	2 - 11 BSPP	Steel	2.81	-	5
2	16VBF16-B	2 - 11 BSPP	Brass	2.81	-	5
2	16VBF16-SS	2 - 11 BSPP	316 SS	2.81	-	5

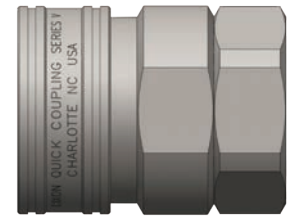

Female Thread

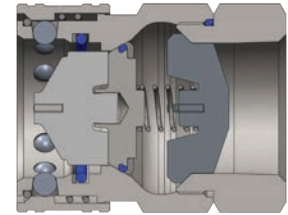

### V-Series Snap-Tite H/H Interchange Valved Nipples

Size (inch)	Part No.	Thread Size (inch)	Body Material	Weight (kg)	Pkg Qty	
					Bag	Box
1¼	V10F10	1¼ - 11½ NPTF	Steel	0.23	-	10
1¼	V10F10-B	1¼ - 11½ NPTF	Brass	0.23	-	10
1¼	V10F10-SS	1¼ - 11½ NPTF	316 SS	0.22	-	10
1¼	V10BF10	1¼ - 11 BSPP	Steel	0.23	-	10
1¼	V10BF10-B	1¼ - 11 BSPP	Brass	0.23	-	10
1¼	V10BF10-SS	1¼ - 11 BSPP	316 SS	0.23	-	10
1¼	V10OF10	1⅝ - 12 ORB	Steel	0.27	-	10
1½	V12F12	1½ - 11½ NPTF	Steel	0.97	-	5
1½	V12F12-B	1½ - 11½ NPTF	Brass	0.97	-	5
1½	V12F12-SS	1½ - 11½ NPTF	316 SS	0.97	-	5
1½	V12BF12	1½ - 11 BSPP	Steel	0.97	-	5
1½	V12BF12-B	1½ - 11 BSPP	Brass	0.97	-	5
1½	V12BF12-SS	1½ - 11 BSPP	316 SS	0.97	-	5
1½	V12OF12	1⅝ - 12 ORB	Steel	1.00	-	5
2	V16F16	2 - 11½ NPTF	Steel	2.15	-	5
2	V16F16-B	2 - 11½ NPTF	Brass	2.15	-	5
2	V16F16-SS	2 - 11½ NPTF	316 SS	2.15	-	5
2	V16BF16	2 - 11 BSPP	Steel	2.15	-	5
2	V16BF16-B	2 - 11 BSPP	Brass	2.15	-	5
2	V16BF16-SS	2 - 11 BSPP	316 SS	2.15	-	5

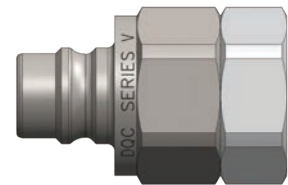

Female Thread

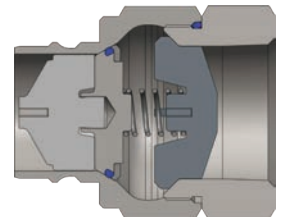

FOR TECHNICAL GUIDELINES PLEASE REFER TO PAGE 243

## V-Series Snap-Tite H/H Interchange Valved Couplers

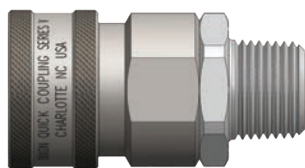

Male Thread

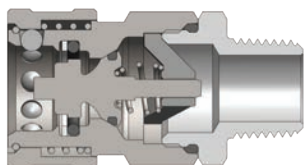

Size (inch)	Part No.	Thread Size (inch)	Body Material	Weight (kg)	Pkg Qty	
					Bag	Box
¼	2VM2	¼ - 18 NPTF	Steel	0.10	5	50
¼	2VM2-B	¼ - 18 NPTF	Brass	0.10	5	50
¼	2VM2-SS	¼ - 18 NPTF	316 SS	0.10	5	50
⅜	3VM3	⅜ - 18 NPTF	Steel	0.11	5	50
⅜	3VM3-B	⅜ - 18 NPTF	Brass	0.11	5	50
⅜	3VM3-SS	⅜ - 18 NPTF	316 SS	0.12	5	50
½	4VM4	½ - 14 NPTF	Steel	0.22	5	25
½	4VM4-B	½ - 14 NPTF	Brass	0.22	5	25
½	4VM4-SS	½ - 14 NPTF	316 SS	0.27	5	25
¾	6VM6	¾ - 14 NPTF	Steel	0.42	5	20
¾	6VM6-B	¾ - 14 NPTF	Brass	0.41	5	20
¾	6VM6-SS	¾ - 14 NPTF	316 SS	0.41	5	20
1	8VM8	1 - 11½ NPTF	Steel	0.61	-	10
1	8VM8-B	1 - 11½ NPTF	Brass	0.60	-	10
1	8VM8-SS	1 - 11½ NPTF	316 SS	0.63	-	10
1¼	10VM10	1¼ - 11½ NPTF	Steel	0.83	-	10
1¼	10VM10-B	1¼ - 11½ NPTF	Brass	0.81	-	10
1¼	10VM10-SS	1¼ - 11½ NPTF	316 SS	0.81	-	10
1½	12VM12	1½ - 11½ NPTF	Steel	1.35	-	5
1½	12VM12-B	1½ - 11½ NPTF	Brass	1.34	-	5
1½	12VM12-SS	1½ - 11½ NPTF	316 SS	1.34	-	5
2	16VM16	2 - 11½ NPTF	Steel	2.72	-	5
2	16VM16-B	2 - 11½ NPTF	Brass	2.72	-	5
2	16VM16-SS	2 - 11½ NPTF	316 SS	2.72	-	5

## V-Series Snap-Tite H/H Interchange Valved Nipples



Male Thread

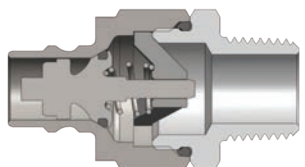

Size (inch)	Part No.	Thread Size (inch)	Body Material	Weight (kg)	Pkg Qty	
					Bag	Box
¼	V2M2	¼ - 18 NPTF	Steel	0.07	5	50
¼	V2M2-B	¼ - 18 NPTF	Brass	0.07	5	50
¼	V2M2-SS	¼ - 18 NPTF	316 SS	0.07	5	50
⅜	V3M3	⅜ - 18 NPTF	Steel	0.10	5	50
⅜	V3M3-B	⅜ - 18 NPTF	Brass	0.10	5	50
⅜	V3M3-SS	⅜ - 18 NPTF	316 SS	0.10	5	50
½	V4M4	½ - 14 NPTF	Steel	0.14	5	25
½	V4M4-B	½ - 14 NPTF	Brass	0.14	5	25
½	V4M4-SS	½ - 14 NPTF	316 SS	0.14	5	25
¾	V6M6	¾ - 14 NPTF	Steel	0.28	5	20
¾	V6M6-B	¾ - 14 NPTF	Brass	0.28	5	20
¾	V6M6-SS	¾ - 14 NPTF	316 SS	0.28	5	20
1	V8M8	1 - 11½ NPTF	Steel	0.49	-	10
1	V8M8-B	1 - 11½ NPTF	Brass	0.49	-	10
1	V8M8-SS	1 - 11½ NPTF	316 SS	0.52	-	10
1¼	V10M10	1¼ - 11½ NPTF	Steel	0.59	-	10
1¼	V10M10-B	1¼ - 11½ NPTF	Brass	0.59	-	10
1¼	V10M10-SS	1¼ - 11½ NPTF	316 SS	0.61	-	10
1½	V12M12	1½ - 11½ NPTF	Steel	1.03	-	5
1½	V12M12-B	1½ - 11½ NPTF	Brass	1.03	-	5
1½	V12M12-SS	1½ - 11½ NPTF	316 SS	1.06	-	5
2	V16M16	2 - 11½ NPTF	Steel	2.16	-	5
2	V16M16-B	2 - 11½ NPTF	Brass	2.16	-	5
2	V16M16-SS	2 - 11½ NPTF	316 SS	2.17	-	5

FOR TECHNICAL GUIDELINES PLEASE REFER TO PAGE 243

## V-Series Snap-Tite H/H Interchange Valved Couplers - JIC

Size (inch)	Part No.	Thread Size (inch)	Body Material	Weight (kg)	Pkg Qty	
					Bag	Box
¼	2VJM2	7/16 - 20 JIC	Steel	0.11	5	50
¾	3VJM3	9/16 - 18 JIC	Steel	0.14	5	50
½	4VJM4	¾ - 16 JIC	Steel	0.23	5	25
¾	6VJM6	1 1/16 - 12 JIC	Steel	0.45	5	20
1	8VJM8	1 5/16 - 12 JIC	Steel	0.67	-	10



JIC Male Thread

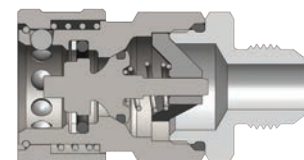

## V-Series Snap-Tite H/H Interchange Valved Nipples - JIC

Size (inch)	Part No.	Thread Size (inch)	Body Material	Weight (kg)	Pkg Qty	
					Bag	Box
¾	V3JM3	9/16 - 18 JIC	Steel	0.11	5	50
½	V4JM4	¾ - 16 JIC	Steel	0.17	5	25
¾	V6JM6	1 1/16 - 12 JIC	Steel	0.32	5	20
1	V8JM8	1 5/16 - 12 JIC	Steel	0.61	-	10



JIC Male Thread

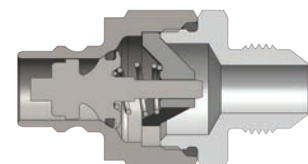

FOR TECHNICAL GUIDELINES PLEASE REFER TO PAGE 243

## V-Series Snap-Tite H/H Interchange Unvalved Couplers



Female Thread

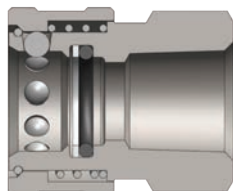

Size (inch)	Part No.	Thread Size (inch)	Body Material	Weight (kg)	Pkg Qty	
					Bag	Box
¼	2VF2-E	¼ - 18 NPTF	Steel	0.08	5	50
¼	2VF2-B-E	¼ - 18 NPTF	Brass	0.08	5	50
¼	2VF2-SS-E	¼ - 18 NPTF	316 SS	0.08	5	50
¼	2VBF2-E	¼ - 19 BSPP	Steel	0.08	5	50
¼	2VBF2-B-E	¼ - 19 BSPP	Brass	0.08	5	50
¼	2VBF2-SS-E	¼ - 19 BSPP	316 SS	0.08	5	50
⅜	3VF3-E	⅜ - 18 NPTF	Steel	0.13	5	50
⅜	3VF3-B-E	⅜ - 19 BSPP	Steel	0.12	5	50
⅜	3VBF3-B-E	⅜ - 19 BSPP	Brass	0.13	5	50
⅜	3VBF3-SS-E	⅜ - 19 BSPP	316 SS	0.12	5	50
½	4VF4-E	½ - 14 NPTF	Steel	0.18	5	25
½	4VF4-B-E	½ - 14 NPTF	Brass	0.18	5	25
½	4VF4-SS-E	½ - 14 NPTF	316 SS	0.17	5	25
½	4VBF4-E	½ - 14 BSPP	Steel	0.16	5	25
½	4VBF4-B-E	½ - 14 BSPP	Brass	0.17	5	25
½	4VBF4-SS-E	½ - 14 BSPP	316 SS	0.16	5	25
¾	6VF6-E	¾ - 14 NPTF	Steel	0.29	5	20
¾	6VF6-B-E	¾ - 14 NPTF	Brass	0.28	5	20
¾	6VF6-SS-E	¾ - 14 NPTF	316 SS	0.28	5	20
¾	6VBF6-E	¾ - 14 BSPP	Steel	0.29	5	20
¾	6VBF6-B-E	¾ - 14 BSPP	Brass	0.31	5	20
¾	6VBF6-SS-E	¾ - 14 BSPP	316 SS	0.29	5	20
1	8VF8-E	1 - 11½ NPTF	Steel	0.48	-	10
1	8VF8-B-E	1 - 11½ NPTF	Brass	0.46	-	10
1	8VF8-SS-E	1 - 11½ NPTF	316 SS	0.46	-	10
1"	8VBF8-E	1" - 11 BSPP	Steel	0.42	-	10
1"	8VBF8-B-E	1" - 11 BSPP	Brass	0.46	-	10
1"	8VBF8-SS-E	1" - 11 BSPP	316 SS	0.42	-	10
1¼	10VF10-E	1¼ - 11½ NPTF	Steel	0.49	-	10
1¼	10VF10-B-E	1¼ - 11½ NPTF	Brass	0.50	-	10
1¼	10VBF10-E	1¼ - 11 BSPP	Steel	0.47	-	10
1¼	10VBF10-B-E	1¼ - 11 BSPP	Brass	0.50	-	10
1½	12VF12-E	1½ - 11½ NPTF	Steel	0.81	-	5
1½	12VF12-B-E	1½ - 11½ NPTF	Brass	0.81	-	5
1½	12VF12-SS-E	1½ - 11½ NPTF	316 SS	0.81	-	5
2	16VF16-E	2 - 11½ NPTF	Steel	1.42	-	5
2	16VF16-SS-E	2 - 11½ NPTF	316 SS	1.42	-	5

E

FOR TECHNICAL GUIDELINES PLEASE REFER TO PAGE 243

## V-Series Snap-Tite H/H Interchange Unvalved Nipples

Size (inch)	Part No.	Thread Size (inch)	Body Material	Weight (kg)	Pkg Qty	
					Bag	Box
¼	V2F2-E	¼ - 18 NPTF	Steel	0.02	5	50
¼	V2F2-B-E	¼ - 18 NPTF	Brass	0.03	5	50
¼	V2F2-SS-E	¼ - 18 NPTF	316 SS	0.03	5	50
¼	V2BF2-E	¼ - 19 BSPP	Steel	0.02	5	50
¼	V2BF2-B-E	¼ - 19 BSPP	Brass	0.02	5	50
¼	V2BF2-SS-E	¼ - 19 BSPP	316 SS	0.02	5	50
⅜	V3F3-E	⅜ - 18 NPTF	Steel	0.04	5	50
⅜	V3F3-B-E	⅜ - 18 NPTF	Brass	0.04	5	50
⅜	V3F3-SS-E	⅜ - 18 NPTF	316 SS	0.04	5	50
⅜	V3BF3-E	⅜ - 19 BSPP	Steel	0.04	5	50
⅜	V3BF3-B-E	⅜ - 19 BSPP	Brass	0.04	5	50
⅜	V3BF3-SS-E	⅜ - 19 BSPP	316 SS	0.04	5	50
½	V4F4-E	½ - 14 NPTF	Steel	0.08	5	25
½	V4F4-B-E	½ - 14 NPTF	Brass	0.08	5	25
½	V4F4-SS-E	½ - 14 NPTF	316 SS	0.08	5	25
½	V4BF4-E	½ - 14 BSPP	Steel	0.08	5	25
½	V4BF4-B-E	½ - 14 BSPP	Brass	0.08	5	25
½	V4BF4-SS-E	½ - 14 BSPP	316 SS	0.08	5	25
¾	V6F6-E	¾ - 14 NPTF	Steel	0.10	5	20
¾	V6F6-B-E	¾ - 14 NPTF	Brass	0.10	5	20
¾	V6F6-SS-E	¾ - 14 NPTF	316 SS	0.10	5	20
¾	V6BF6-E	¾ - 14 BSPP	Steel	0.10	5	20
¾	V6BF6-B-E	¾ - 14 BSPP	Brass	0.10	5	20
¾	V6BF6-SS-E	¾ - 14 BSPP	316 SS	0.10	5	20
1	V8F8-E	1 - 11½ NPTF	Steel	0.17	-	10
1	V8F8-B-E	1 - 11½ NPTF	Brass	0.17	-	10
1	V8F8-SS-E	1 - 11½ NPTF	316 SS	0.17	-	10
1	V8BF8-E	1 - 11 BSPP	Steel	0.17	-	10
1	V8BF8-B-E	1 - 11 BSPP	Brass	0.18	-	10
1	V8BF8-SS-E	1 - 11 BSPP	316 SS	0.17	-	10
1¼	V10F10-E	1¼ - 11½ NPTF	Steel	0.26	-	10
1¼	V10F10-B-E	1¼ - 11½ NPTF	Brass	0.25	-	10
1¼	V10BF10-E	1¼ - 11 BSPP	Steel	0.27	-	10
1¼	V10BF10-B-E	1¼ - 11 BSPP	Brass	0.29	-	10
1½	V12F12-E	1½ - 11½ NPTF	Steel	0.38	-	5
1½	V12F12-B-E	1½ - 11½ NPTF	Brass	0.38	-	5
1½	V12F12-SS-E	1½ - 11½ NPTF	316 SS	0.38	-	5
2	V16F16-E	2 - 11½ NPTF	Steel	0.61	-	5
2	V16F16-SS-E	2 - 11½ NPTF	316 SS	0.61	-	5

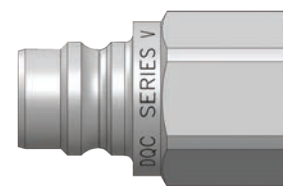

Female Thread

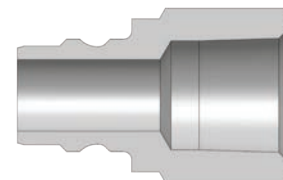

E

FOR TECHNICAL GUIDELINES PLEASE REFER TO PAGE 243

## V-Series Snap-Tite H/H Interchange Unvalved Couplers



Male Thread

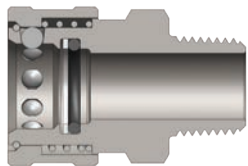

Size (inch)	Part No.	Thread Size (inch)	Body Material	Weight (kg)	Pkg Qty	
					Bag	Box
¼	2VM2-E	¼ - 18 NPTF	Steel	0.09	5	50
¼	2VM2-B-E	¼ - 18 NPTF	Brass	0.09	5	50
¼	2VM2-SS-E	¼ - 18 NPTF	316 SS	0.09	5	50

## V-Series Snap-Tite H/H Interchange Unvalved Nipples



Male Thread

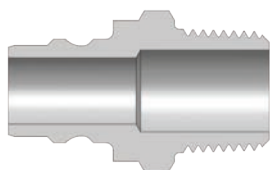

Size (inch)	Part No.	Thread Size (inch)	Body Material	Weight (kg)	Pkg Qty	
					Bag	Box
¼	V2M2-E	¼ - 18 NPTF	Steel	0.07	5	50
¼	V2M2-B-E	¼ - 18 NPTF	Brass	0.07	5	50
¼	V2M2-SS-E	¼ - 18 NPTF	316 SS	0.07	5	50
⅜	V3M3-E	⅜ - 18 NPTF	Steel	0.05	5	50
⅜	V3M3-B-E	⅜ - 18 NPTF	Brass	0.05	5	50
⅜	V3M3-SS-E	⅜ - 18 NPTF	316 SS	0.05	5	50
½	V4M4-E	½ - 14 NPTF	Steel	0.06	5	25
½	V4M4-B-E	½ - 14 NPTF	Brass	0.06	5	25
½	V4M4-SS-E	½ - 14 NPTF	316 SS	0.06	5	25
¾	V6M6-E	¾ - 14 NPTF	Steel	0.14	5	20
¾	V6M6-B-E	¾ - 14 NPTF	Brass	0.13	5	20
¾	V6M6-SS-E	¾ - 14 NPTF	316 SS	0.13	5	20
1	V8M8-E	1 - 11½ NPTF	Steel	0.18	-	10
1	V8M8-B-E	1 - 11½ NPTF	Brass	0.18	-	10
1	V8M8-SS-E	1 - 11½ NPTF	316 SS	0.18	-	10
1¼	V10M10-E	1¼ - 11½ NPTF	Steel	0.37	-	10
2	V16M16-SS-E	2 - 11½ NPTF	316 SS	0.65	-	5

## V-Series Dust Caps & Dust Plugs



Size (inch)	Part No.	Material	Pkg Qty	
			Bag	Box
⅜	3VDP-V3DC	Nitrile	10	50
½	4VDP-V4DC	Nitrile	10	50
¾	6VDP-V6DC	Nitrile	5	25
1	8VDP-V8DC	Nitrile	5	25

FOR TECHNICAL GUIDELINES PLEASE REFER TO PAGE 243

## V-Series Coupler Rigid Dust Plugs

Size (inch)	Part No.	Lanyard	Body Material	Weight (kg)	Pkg Qty	
					Bag	Box
3/8	3VDP-A	SS Bead Chain	Aluminium	0.01	5	50
1/2	4VDP-A	SS Bead Chain	Aluminium	0.01	5	25
3/4	6VDP-A	SS Bead Chain	Aluminium	0.04	5	20
1	8VDP-A	SS Bead Chain	Aluminium	0.06	-	10
1 1/4	10VDP-A	SS Bead Chain	Aluminium	0.13	-	10
1 1/2	12VDP-A	SS Bead Chain	Aluminium	0.14	-	10
2	16VDP-A	SS Bead Chain	Aluminium	0.22	-	10



## V-Series Nipple Rigid Dust Caps

Size (inch)	Part No.	Lanyard	Body Material	Weight (kg)	Pkg Qty	
					Bag	Box
1/4	V2DC-A	SS Bead Chain	Aluminium	0.01	5	50
1/2	V4DC-A	SS Bead Chain	Aluminium	0.06	5	25
3/4	V6DC-A	SS Bead Chain	Aluminium	0.09	5	20
1	V8DC-A	SS Bead Chain	Aluminium	0.12	-	10
1 1/4	V10DC-A	SS Bead Chain	Aluminium	0.11	-	10
1 1/2	V12DC-A	SS Bead Chain	Aluminium	0.17	-	10
2	V16DC-A	SS Bead Chain	Aluminium	0.24	-	10



## V-Series Snap-Tite H/H Interchange Coupler Seal Kits

Size (inch)	Part No.	Coupler Style	Seal Material	Seal Kit Contents	Pkg Qty	
					Bag	Box
1/4	2V-SKIT	All	Nitrile	Body / Adaptor O-rings & PTFE Back-up	25	200
3/8	3V-SKIT	All	Nitrile	Body / Adaptor O-rings & PTFE Back-up	25	200
1/2	4V-SKIT	All	Nitrile	Body / Adaptor O-rings & PTFE Back-up	25	200
3/4	6V-SKIT	All	Nitrile	Body / Adaptor O-rings & PTFE Back-up	25	200
1 1/4	10V-SKIT	All	Nitrile	Body / Adaptor / Valve O-rings & Back-up	10	50
1 1/2	12V-SKIT	All	Nitrile	Body / Adaptor / Valve O-rings & Back-up	10	50
2	16V-SKIT	All	Nitrile	Body / Adaptor / Valve O-rings & Back-up	10	50

## V-Series Snap-Tite H/H Interchange Coupler Repair Kits

Size (inch)	Part No.	Coupler Material	Seal Material	Repair Kit Contents (for one coupler)	Pkg Qty	
					Bag	Box
3/4	6V-RKIT	Steel	Nitrile	Steel Valve Assembly & Adaptor O-ring	1	25
1	8V-RKIT	Steel	Nitrile	Steel Valve Assembly & Adaptor O-ring	1	25

## V-Series Snap-Tite H/H Interchange Nipple Repair Kits

Size (inch)	Part No.	Coupler Material	Seal Material	Repair Kit Contents (for one coupler)	Pkg Qty	
					Bag	Box
1/4	V2-RKIT	Steel	Nitrile	Steel Valve Assembly & Adaptor O-ring	1	25
3/8	V3-RKIT	Steel	Nitrile	Steel Valve Assembly & Adaptor O-ring	1	25
1/2	V4-RKIT	Steel	Nitrile	Steel Valve Assembly & Adaptor O-ring	1	25
3/4	V6-RKIT	Steel	Nitrile	Steel Valve Assembly & Adaptor O-ring	1	25
1	V8-RKIT	Steel	Nitrile	Steel Valve Assembly & Adaptor O-ring	1	25

FOR TECHNICAL GUIDELINES PLEASE REFER TO PAGE 243

# Hydraulic & Pneumatic

## CVV-Series European Screw-Together Interchange

<b>Materials:</b>	<ul style="list-style-type: none"> <li>Machined components are manufactured using solid steel bar stock</li> <li>Steel retaining rings and springs maximise service life in rugged environments</li> <li>Steel componentry is plated using ROHS-compliant trivalent chrome</li> </ul>
<b>Seal Components:</b>	<ul style="list-style-type: none"> <li>Nitrile (Buna-N) seals are standard, providing a temperature range of <b>-25°C to 125°C (-13°F to 257°F)</b></li> <li>Nipples have a PTFE anti-extrusion ring to prevent O-ring damage during dynamic impulse service</li> </ul>
<b>Interchange Data:</b>	<ul style="list-style-type: none"> <li>European screw-together interchange</li> <li>Inteva STG-Series, Faster CVV-Series, DNP PVV3, Voswinkel Type-HS</li> </ul>

Size (inch)	Coupler / Plug Coupled			
	Working Pressure		Burst Pressure	
	PSI	Bar	PSI	Bar
¼	6,500	450	26,000	1800
⅜	6,500	450	26,000	1800
½	5,800	400	23,200	1600
¾	5,800	400	23,200	1600
1	4,400	300	17,600	1300
1¼	4,400	300	17,600	1200

Size (inch)	Interchange Standards				Functional Parameters				
	US Military	US Government	International Standards	ANSI / NFPA Standards	Locking Mechanism	Air Inclusion	Fluid Loss	Vacuum inch HG	Flow (Lpm) ΔP = 22 PSI
¼	-	-	-	-	Threaded	N/A	N/A	27.4	26
⅜	-	-	-	-	Threaded	N/A	N/A	27.4	37
½	-	-	-	-	Threaded	N/A	N/A	27.4	56
¾	-	-	-	-	Threaded	N/A	N/A	27.4	98
1	-	-	-	-	Threaded	N/A	N/A	27.4	170
1¼	-	-	-	-	Threaded	N/A	N/A	27.4	265

Note: Threaded sleeves enable easy connection and disconnection while system is under residual pressure only.

## CVV-Series European Interchange Couplers

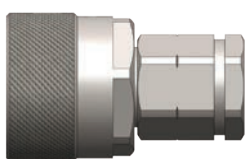

Female Thread

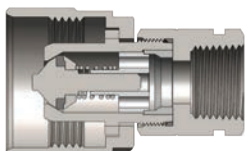

Size (inch)	Part No.	Thread Size (inch)	Body Material	Weight (kg)	Pkg Qty	
					Bag	Box
¼	2CVVF2	¼ - 18 NPTF	Steel	0.12	10	50
¼	2CVVBF2	¼ - 19 BSPP	Steel	0.12	10	50
¼	2CVVFM1415	M14X1.5	Steel	0.13	10	50
⅜	3CVVF3	⅜ - 18 NPTF	Steel	0.23	10	30
⅜	3CVVBF3	⅜ - 19 BSPP	Steel	0.23	10	30
⅜	3CVVFM1615	M16X1.5	Steel	0.22	10	30
½	4CVVF4	½ - 14 NPTF	Steel	0.34	5	25
½	4CVVOF4	¾ - 16 ORB	Steel	0.34	5	25
½	4CVVBF4	½ - 14 BSPP	Steel	0.34	5	25
½	4CVVFM1815	M18X1.5	Steel	0.35	5	25
½	4CVVOF5	⅞ - 14 ORB	Steel	0.35	5	25
½	4CVVFM2215	M22X1.5	Steel	0.34	5	25
¾	6CVVF6	¾ - 14 NPTF	Steel	0.58	-	10
¾	6CVVBF6	¾ - 14 BSPP	Steel	0.58	-	10
¾	6CVVFM2215	M22X1.5	Steel	0.58	-	10
1	8CVVF8	1 - 11½ NPTF	Steel	0.81	-	10
1	8CVVBF8	1 - 11 BSPP	Steel	0.81	-	10
1¼	10CVVF10	1¼ - 11½ NPTF	Steel	1.20	-	10
1¼	10CVVBF10	1¼ - 11 BSPP	Steel	1.20	-	10



## CVV-Series European Interchange Nipples

Size (inch)	Part No.	Thread Size (inch)	Body Material	Weight (kg)	Pkg Qty	
					Bag	Box
¼	CVV2F2	¼ - 18 NPTF	Steel	0.11	10	50
¼	CVV2BF2	¼ - 19 BSPP	Steel	0.11	10	50
¼	CVV2FM1415	M14X1.5	Steel	0.10	10	50
⅜	CVV3F3	⅜ - 18 NPTF	Steel	0.22	10	30
⅜	CVV3BF3	⅜ - 19 BSPP	Steel	0.22	10	30
⅜	CVV3FM1615	M16X1.5	Steel	0.21	10	30
½	CVV4F4	½ - 14 NPTF	Steel	0.34	5	25
½	CVV4OF4	½ - 16 ORB	Steel	0.34	5	25
½	CVV4BF4	½ - 14 BSPP	Steel	0.34	5	25
½	CVV4FM1815	M18X1.5	Steel	0.35	5	25
½	CVV4OF5	⅞ - 14 ORB	Steel	0.35	5	25
½	CVV4FM2215	M22X1.5	Steel	0.34	5	25
¾	CVV6F6	¾ - 14 NPTF	Steel	0.58	-	10
¾	CVV6BF6	¾ - 14 BSPP	Steel	0.58	-	10
¾	CVV6FM2215	M22X1.5	Steel	0.58	-	10
1	CVV8F8	1 - 11½ NPTF	Steel	0.81	-	10
1	CVV8BF8	1 - 11 BSPP	Steel	0.81	-	10
1¼	CVV10F10	1¼ - 11½ NPTF	Steel	1.20	-	10
1¼	CVV10BF10	1¼ - 11 BSPP	Steel	1.20	-	10

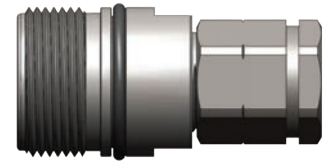

Female Thread

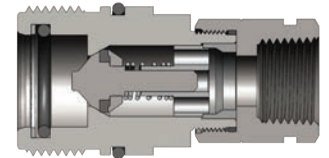

## CVV-Series European Interchange Dust Plugs

Size (inch)	Part No.	Lanyard	Body Material	Weight (kg)	Pkg Qty	
					Bag	Box
¼	2CVVDP	Plastic	Plastic	0.01	5	25
⅜	3CVVDP	Plastic	Plastic	0.01	5	25
½	4CVVDP	Plastic	Plastic	0.03	5	25
¾	6CVVDP	Plastic	Plastic	0.03	5	25
1	8CVVDP	Plastic	Plastic	0.04	5	25
1¼	10CVVDP	Plastic	Plastic	0.05	-	10



E

## CVV-Series European Interchange Dust Caps

Size (inch)	Part No.	Lanyard	Body Material	Weight (kg)	Pkg Qty	
					Bag	Box
¼	CVV2DC	Plastic	Plastic	0.01	5	25
⅜	CVV3DC	Plastic	Plastic	0.01	5	25
½	CVV4DC	Plastic	Plastic	0.02	5	25
¾	CVV6DC	Plastic	Plastic	0.04	5	25
1	CVV8DC	Plastic	Plastic	0.04	5	25
1¼	CVV10DC	Plastic	Plastic	0.07	-	10



FOR TECHNICAL GUIDELINES PLEASE REFER TO PAGE 254

# Hydraulic & Pneumatic

## PD-Series ISO15171-1 Diagnostic Interchange

<b>Materials:</b>	<ul style="list-style-type: none"> <li>Machined components are manufactured using solid steel bar stock</li> <li>Stainless steel balls, retaining rings, and springs maximise corrosion resistance and extend service life</li> <li>Steel componentry is plated using ROHS-compliant trivalent chrome</li> <li>Steel nipples are machined from solid steel bar stock and hardened</li> </ul>
<b>Seal Components:</b>	<ul style="list-style-type: none"> <li>Nitrile (Buna-N) seals are standard, providing a temperature range of <b>-40°C to 121°C (-40°F to 249°F)</b></li> <li>PTFE anti-extrusion ring protects main coupler O-ring from dynamic impulse pressure damage</li> </ul>
<b>Interchange Data:</b>	<ul style="list-style-type: none"> <li>Interchangeable to ISO15171-1</li> <li>Parker PD-Series, Aeroquip FD90, Tomco Series DK</li> </ul>

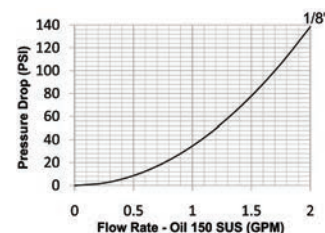

Size (inch)	Steel Coupler / Plug Coupled				Steel Plug Uncoupled			
	Working Pressure		Burst Pressure		Working Pressure		Burst Pressure	
	PSI	Bar	PSI	Bar	PSI	Bar	PSI	Bar
1/8	6,000	400	18,700	1300	6,000	400	24,000	1600

Size (inch)	Interchange Standards				Functional Parameters				
	US Military	US Government	International Standards	ANSI / NFPA Standards	Locking Ball Qty	Air Inclusion	Fluid Loss	Vacuum inch HG	Flow (Lpm) ΔP = 22 PSI
1/8	-	-	ISO15171-1	SAE J1502	10	0.02	0.1	27.4	3.0

## PD-Series ISO15171-1 Diagnostic Interchange Couplers



Female Thread

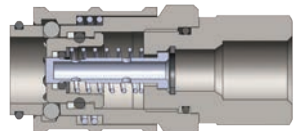

Size (inch)	Part No.	Thread Size (inch)	Body Material	Weight (kg)	Pkg Qty	
					Bag	Box
1/8	1PDF1	1/8 - 27 NPT	Steel	0.08	10	100
1/8	1PDF2	1/4 - 18 NPT	Steel	0.07	10	100

## PD-Series ISO15171-1 Diagnostic Interchange Nipples



Female Thread

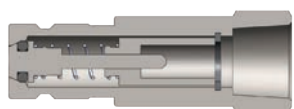

Size (inch)	Part No.	Thread Size (inch)	Body Material	Weight (kg)	Pkg Qty	
					Bag	Box
1/8	PD1F1	1/8 - 27 NPT	Steel	0.02	10	100
1/8	PD1F2	1/4 - 18 NPT	Steel	0.02	10	100

## PD-Series ISO15171-1 Diagnostic Interchange Couplers

Size (inch)	Part No.	Thread Size (inch)	Body Material	Weight (kg)	Pkg Qty	
					Bag	Box
1/4	1PDM2	1/4 - 18 NPT	Steel	0.08	10	100



Male Thread

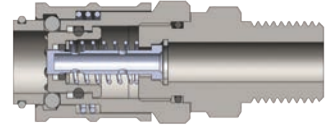

## PD-Series ISO15171-1 Diagnostic Interchange Nipples

Size (inch)	Part No.	Thread Size (inch)	Body Material	Weight (kg)	Pkg Qty	
					Bag	Box
1/4	PD1M1	1/8 - 27 NPT	Steel	0.02	10	100
1/4	PD1M2	1/4 - 18 NPT	Steel	0.02	10	100



Male Thread

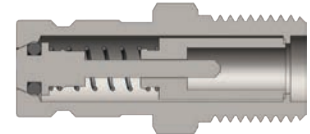

## PD-Series ISO15171-1 Diagnostic Interchange Nipples - ORB

Size (inch)	Part No.	Thread Size (inch)	Body Material	Weight (kg)	Pkg Qty	
					Bag	Box
1/4	PD1OM2	7/16 - 20 ORB	Steel	0.03	10	100
1/4	PD1OM3	9/16 - 18 ORB	Steel	0.03	10	100



Male ORB Thread

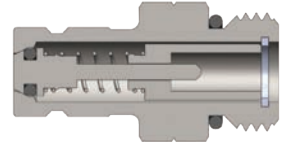

## PD-Series Nipple Dust Cap

Size (inch)	Part No.	Body Material	Pkg Qty	
			Bag	Box
1/4	H1DC	Nitrile	5	50



## PD-Series Profile

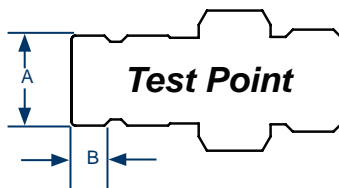

Size (inch)	A (mm)	B (mm)
1/4	12.70	4.76

FOR TECHNICAL GUIDELINES PLEASE REFER TO PAGE 256

# Pipe, Pipe Fittings & Welding Index



F

Quick-Release Couplings .....	259
Standard Couplings .....	260
Lightweight Flexible Couplings .....	261
Lite® Couplings .....	262
Rigid Couplings .....	263
Grooved Clamps .....	264
Grooved Gaskets .....	265-266

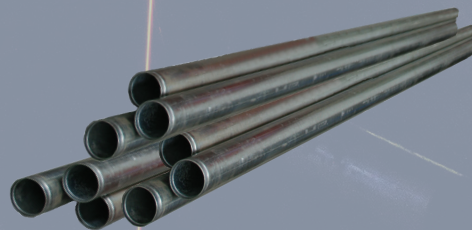

## Quick-Release Couplings - Series Q

<b>Application:</b>	• Designed for a quick connection and/or disconnection of a pipe joint, a locking pin through the handle prevents accidental opening of the coupling
<b>Features:</b>	• Ductile iron body with zinc plating and steel safety clip
<b>Standards:</b>	• Comparable to Victaulic's #78 and Grinnell's #7003



Size NB	Nominal Size (inch)	Nominal Size (mm)	Pipe OD (inch)	Maximum Working Pressure PSI at 21°C (70°F)	Maximum End Load (Lbs.)	Ductile Iron	
						Part # with EPDM gasket	Part # with Buna-N gasket
40	1½	48	1.900	300	850	H315	H315BU
50	2	60	2.375	300	1,329	H32	H32BU
65	2½	73	2.875	300	2,120	H325	H325BU
80	3	49	3.500	300	2,886	H33	H33BU
100	4	114	4.500	300	4,771	H34	H34BU
150	6	168	6.625	300	10,341	H36	H36BU

Note: See page 266 for replacement gaskets

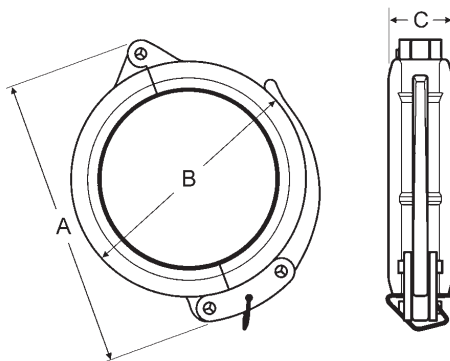

Dimensions

A		B		C	
inch	mm	inch	mm	inch	mm
4¾	120	3½	89	1	25
5½	139	3¾	95	1⅞	48
5⅝	149	4¾	120	1⅞	48
7¼	184	5¼	133	1⅞	48
8½	216	6½	165	2	50
10⅝	270	8½	216	2	50



# Pipe, Pipe Fittings & Welding

## Standard Couplings - Series S, Style 11

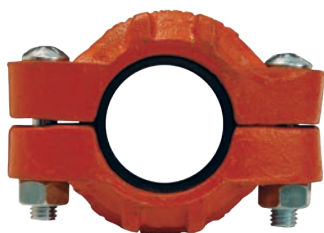
**Application:**

- Designed for a wide range of applications including commercial/industrial construction, mining, and process piping

**Features:**

- Ductile iron body with rust-inhibiting paint
- Housing design allows for optimum strength without excessive casting weight

**Standards:**

- Underwriters Listed and Factory Mutual approved
- Comparable to Victaulic's #77 and Grinnell's #7001

Size NB	Nominal Size (inch)	Nominal Size (mm)	Pipe OD (inch)	Maximum Working Pressure PSI at 21°C (70°F)	Maximum End Load (Lbs.)	Bolts			Ductile Iron	
						qty	size (inch)	length (inch)	Part # with EPDM gasket	Part # with Buna-N gasket
40	1½	48	1.900	1,000	2,835	2	¾	2	C115	C115BU
50	2	60	2.375	1,000	4,430	2	½	2¾	C12	C12BU
65	2½	73	2.875	1,000	6,492	2	½	2¾	C125	C125BU
80	3	89	3.500	1,000	9,621	2	½	3	C13	C13BU
100	4	114	4.500	1,000	15,904	2	⅝	3¼	C14	C14BU
150	6	168	6.625	1,000	34,472	2	¾	4¼	C16	C16BU
200	8	219	8.625	800	46,741	2	⅞	5	C18	C18BU
300	10	273	10.750	800	72,610	2	⅞	5	C20	C20BU
400	12	323	12.750	800	102,141	2	⅞	5	C24	C24BU

Note: See page 266 for replacement gaskets

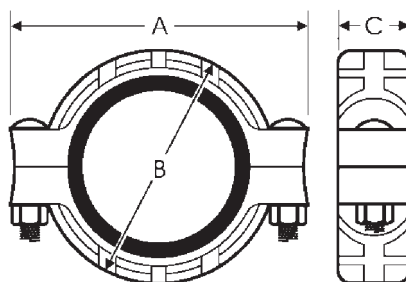

Dimensions

A		B		C	
inch	mm	inch	mm	inch	mm
4⅝	117	3	76	1⅞	47
5 <sup>15</sup> / <sub>64</sub>	133	3 <sup>45</sup> / <sub>64</sub>	94	1 <sup>27</sup> / <sub>32</sub>	48
5⅝	143	4¼	107	1 <sup>27</sup> / <sub>32</sub>	48
6 <sup>21</sup> / <sub>32</sub>	169	5	127	1 <sup>27</sup> / <sub>32</sub>	48
8 <sup>17</sup> / <sub>64</sub>	210	6⅜	162	2 <sup>3</sup> / <sub>64</sub>	52
11 <sup>7</sup> / <sub>32</sub>	285	8 <sup>57</sup> / <sub>64</sub>	226	2 <sup>3</sup> / <sub>64</sub>	52
14 <sup>1</sup> / <sub>64</sub>	355	11⅞	289	2 <sup>3</sup> / <sub>64</sub>	60
16⅝	422	13½	343	2⅝	66
18⅝	473	15½	394	2⅝	66

F

## Lightweight Flexible Couplings - Series L, Style 10



<b>Application:</b>	<ul style="list-style-type: none"> <li>Designed for applications requiring moderate internal pressure or where weight is a factor, such as general purpose, mining, irrigation, and compressed air, where a deflection of 5% or less is required</li> </ul>
<b>Features:</b>	<ul style="list-style-type: none"> <li>Ductile iron body with rust inhibiting paint</li> <li>Housing design allows for optimum strength without excessive casting weight</li> </ul>
<b>Standards:</b>	<ul style="list-style-type: none"> <li>Underwriters Listed and Factory Mutual approved</li> <li>Comparable to Victaulic's #75 and Grinnell's #7000</li> </ul>



Size NB	Nominal Size (inch)	Nominal Size (mm)	Pipe OD (inch)	Maximum Working Pressure PSI at 21°C (70°F)	Maximum End Load (Lbs.)	Bolts			Ductile Iron	
						qty	size (inch)	length (inch)	Part # with EPDM gasket	Part # with Buna-N gasket
40	1½	48	1.900	500	1,418	2	¾	2¼	L215	L215BU
50	2	60	2.375	500	2,215	2	¾	2	L02	L02BU
65	2½	73	2.875	300	3,246	2	¾	2	L025	L025BU
80	3	89	3.500	300	4,811	2	½	2¾	L03	L03BU
100	4	114	4.500	300	6,362	2	½	2¾	L04	L04BU
125	5	127	5.563	300	9,722	2	¾	3¼	L05	L05BU
150	6	168	6.625	300	13,789	2	¾	3¼	L06	L06BU
200	8	219	8.625	300	20,449	2	¾	4¼	L08	L08BU
300	10	273	10.750	350	29,815	2	¾	4¼	L010	L010BU
400	12	323	12.750	350	40,581	2	¾	5	L012	L012BU

Note: See page 266 for replacement gaskets

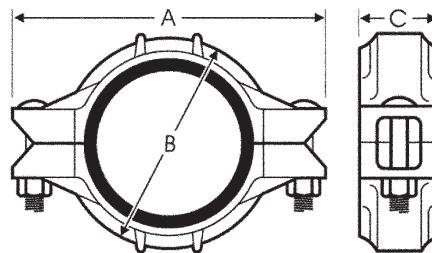

Dimensions

A		B		C	
inch	mm	inch	mm	inch	mm
4½	114	2 <sup>29</sup> / <sub>32</sub>	74	1 <sup>25</sup> / <sub>32</sub>	4
4¾	124	3 <sup>25</sup> / <sub>64</sub>	86	1 <sup>27</sup> / <sub>32</sub>	47
5 <sup>15</sup> / <sub>32</sub>	139	3 <sup>45</sup> / <sub>64</sub>	94	1 <sup>27</sup> / <sub>32</sub>	47
6 <sup>27</sup> / <sub>64</sub>	163	4 <sup>39</sup> / <sub>64</sub>	117	1 <sup>27</sup> / <sub>32</sub>	47
7 <sup>33</sup> / <sub>64</sub>	191	5 <sup>7</sup> / <sub>8</sub>	149	1 <sup>1</sup> / <sub>64</sub>	51
9 <sup>17</sup> / <sub>32</sub>	242	7 <sup>3</sup> / <sub>32</sub>	180	2 <sup>1</sup> / <sub>64</sub>	51
10 <sup>7</sup> / <sub>16</sub>	265	8 <sup>7</sup> / <sub>64</sub>	206	2 <sup>3</sup> / <sub>64</sub>	52
13 <sup>15</sup> / <sub>32</sub>	342	10 <sup>5</sup> / <sub>32</sub>	258	2 <sup>13</sup> / <sub>32</sub>	61
15¾	400	12 <sup>39</sup> / <sub>64</sub>	320	2 <sup>9</sup> / <sub>16</sub>	65
18 <sup>23</sup> / <sub>64</sub>	466	15 <sup>7</sup> / <sub>16</sub>	392	2 <sup>9</sup> / <sub>16</sub>	65



## Lite® Couplings - Stainless Steel



<b>Application:</b>	<ul style="list-style-type: none"> <li>Designed for use on rigid, locked-in pipe connections</li> </ul>
<b>Features:</b>	<ul style="list-style-type: none"> <li>316 cast stainless steel body, nuts, and bolts</li> <li>Ideal for corrosive environments</li> <li>Use of suitable anti-galling thread compound is recommended</li> </ul>
<b>Standards:</b>	<ul style="list-style-type: none"> <li>Certified to ANSI/NSF 61</li> <li>Comparable to Grinnell's #7400 SS</li> </ul>

Size NB	Nominal Size (inch)	Nominal Size (mm)	Pipe OD (inch)	Maximum Working Pressure (PSI)	Maximum End Load (Lbs.)	Bolts			316 Stainless Steel with Fluoro-elastomer Gasket Part #
						qty	size (inch)	length (inch)	
50	2	60	2.375	300	1,329	2	3/8	2 1/4	RL02V
80	3	89	3.500	300	2,886	2	1/2	2 3/4	RL03V
100	4	114	4.500	300	4,771	2	1/2	2 3/4	RL04V

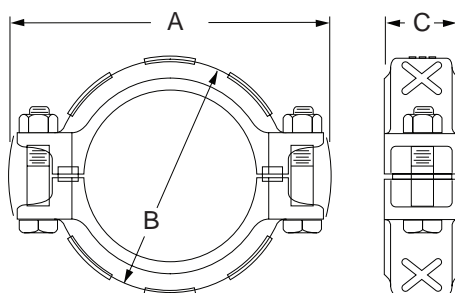

Dimensions

A		B		C	
inch	mm	inch	mm	inch	mm
5 3/8	136	3 5/8	86	1 3/4	44
6 5/8	162	4 5/8	111	1 3/4	44
7 3/4	197	6	152	1 7/8	48

F



# Pipe, Pipe Fittings & Welding

## Rigid Couplings - Series R, Style 5

<b>Application:</b>	• Ideal for fire protection, plumbing, low-pressure air, and drainage
<b>Features:</b>	<ul style="list-style-type: none"> <li>• Lightweight, low pressure</li> <li>• Galvanised ductile iron body</li> <li>• Small gripping teeth hold the housing into the groove allowing a straight run of pipe and preventing any flex at the joint</li> </ul>
<b>Standards:</b>	• Underwriters Listed and Factory Mutual approved



Size NB	Nominal Size (inch)	Nominal Size (mm)	Pipe OD (inch)	Maximum Working Pressure PSI at 21°C (70°F)	Maximum End Load (Lbs.)	Bolts			Ductile Iron	
						qty	size (inch)	length (inch)	Part # with EPDM gasket	Part # with Buna-N gasket
50	2	60	2.375	175	4,425	2	3/8	2	R72	R72BU
65	2½	73	2.875	175	6,490	2	3/8	2	R725	R725BU
80	3	89	3.500	175	9,620	2	½	2¾	R73	R73BU
100	4	114	4.500	175	12,720	2	½	2¾	R74	R74BU
150	6	168	6.625	175	27,570	2	¾	3¾	R76	R76BU
200	8	219	8.625	175	35,050	2	¾	4¾	R78	R78BU

Note: See page 266 for replacement gaskets

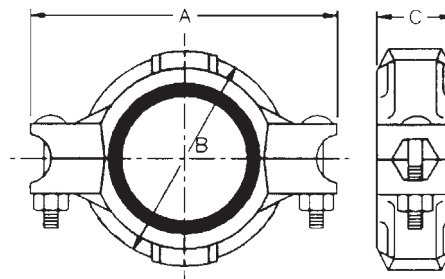

Dimensions

A		B		C	
inch	mm	inch	mm	inch	mm
4 7/8	124	3 17/32	90	1 27/32	47
5 5/8	143	3 45/64	94	1 3/4	44
6 3/8	161	4 41/64	118	1 27/32	47
7 45/64	196	5 15/16	151	2	50
10 25/32	274	8 7/64	206	2 3/64	52
13 25/32	350	10"	254	2 21/64	59



# Pipe, Pipe Fittings & Welding

## Grooved Bolted Clamps



clamp with black buna gasket

<b>Application:</b>	<ul style="list-style-type: none"> <li>Unlike steel groove clamps that secure pipe ends with high clamp force against the tubing walls, the Dixon™ bolted clamp takes the full bolt force and locks in the groove of the tube, preventing distortion of the tube diameter</li> </ul>
<b>Features:</b>	<ul style="list-style-type: none"> <li>Precision casting and machined dimensions provide an exact fit and great appearance</li> <li>Use of lock nuts prevents clamps from loosening in high-vibration applications</li> <li>Leak-tight connection</li> </ul>
<b>Gasket Rating:</b>	<ul style="list-style-type: none"> <li>FKM-B rated for 100% biodiesel and ethanol</li> <li>Buna-N rated for petroleum service, ethanol to E100, and biodiesel to B20</li> <li>Baylast™ rated for petroleum service, ethanol to E100, and biodiesel to B100</li> <li>White buna-N for use in dry bulk food applications</li> <li>Gasket ships separately and must be installed prior to use</li> </ul>
<b>Pressure Rating:</b>	<ul style="list-style-type: none"> <li>2" is <b>400 PSI</b>; 3" is <b>170 PSI</b>; 4" is <b>120 PSI</b></li> </ul>
<b>Temperature:</b>	<ul style="list-style-type: none"> <li>FKM-B is <b>-7°C to 149°C (20°F to 300°F)</b></li> <li>Baylast is <b>-29°C to 82°C (-20°F to 180°F)</b></li> </ul>

Size (inch)	Size (mm)	Gasket Material	Aluminium Part #
2	60	FKM-B	DBV-VB200
3	89	FKM-B	DBV-VB300
4	114	FKM-B	DBV-VB400
2	60	buna-N	DBV-BN200
3	89	buna-N	DBV-BN300
4	114	buna-N	DBV-BN400
2	60	Baylast™	DBV-BL200
3	89	Baylast™	DBV-BL300
4	114	Baylast™	DBV-BL400
4	114	white buna-N	DBV-WB400

## Replacement Gaskets

Size (inch)	Size (mm)	Material	Part #
2	60	FKM-B	G200VB
3	89	FKM-B	G300VB
4	114	FKM-B	G400VB
3	89	buna-N	G300T
4	114	buna-N	G400T
2	60	Baylast™	G200BL
3	89	Baylast™	G300BL
4	114	Baylast™	G400BL
4	114	white buna-N	G400N



Intended for tank truck application only.

F



## Painted Iron Clamps with Baylast™ Gaskets



<b>Features:</b>	<ul style="list-style-type: none"> <li>Painted red</li> </ul>
<b>Seal:</b>	<ul style="list-style-type: none"> <li>Baylast™ seal is rated for biodiesel, ethanol, diesel, gas, and ULSD</li> </ul>

Size (inch)	Size (mm)	Maximum PSI	Iron Part #
2	60	<b>500</b>	L02BL
3	89	<b>300</b>	L03BL
4	114	<b>300</b>	L04BL

## Grooved Fitting Gaskets - FKM Gaskets

<b>Features:</b>	<ul style="list-style-type: none"> <li>Resistant to oxidizing acids, petroleum oils, hydraulic fluids, halogenated hydrocarbons, and lubricants</li> <li>For services not listed contact Dixon™ for recommendations</li> </ul>
<b>Temperature:</b>	<ul style="list-style-type: none"> <li>-11°C to 177°C (-13°F to 350°F)</li> </ul>
<b>Colour Code:</b>	<ul style="list-style-type: none"> <li>Black with blue stripe</li> <li>Check gasket colour code to be certain it is recommended for the service intended</li> </ul>
<b>Specification:</b>	<ul style="list-style-type: none"> <li>Use lubricant on gasket (reference next page)</li> </ul>

Size (inch)	Size (mm)	FKM Part #
2	60	G200V
3	89	G300V
4	114	G400V
6	168	G600V
8	219	G800V
10	273	G1000V
12	323	G1200V

 Not for use with hydrocarbons.

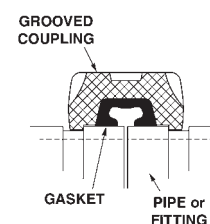

## Grooved Fitting Gaskets - EPDM Gaskets

<b>Features:</b>	<ul style="list-style-type: none"> <li>For water, dilute acids, alkalis, salts, and many chemical services not involving hydrocarbons, oils, or gases</li> <li>Excellent oxidation resistance</li> <li>For services not listed contact Dixon™ for recommendations</li> </ul>
<b>Temperature:</b>	<ul style="list-style-type: none"> <li>-30°C to 110°C (-22°F to 230°F)</li> </ul>
<b>Colour Code:</b>	<ul style="list-style-type: none"> <li>Black with green stripe</li> <li>Check gasket colour code to be certain it is recommended for the service intended</li> </ul>
<b>Specification:</b>	<ul style="list-style-type: none"> <li>Use lubricant on gasket (reference next page)</li> </ul>

Size (inch)	Size (mm)	EPDM Part #
1½	48	G150E
2	60	G200E
2½	73	G250E
3	89	G300E
4	114	G400E
5	127	G500E
6	168	G600E
8	219	G800E
10	273	G1000E
12	323	G1200E

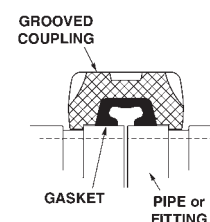

F

# Pipe, Pipe Fittings & Welding

## Grooved Fitting Gaskets - Buna Gaskets

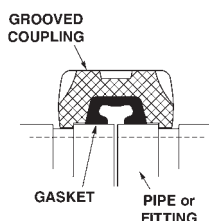

<b>Features:</b>	<ul style="list-style-type: none"> <li>For petroleum products, vegetable oils, mineral oils, and air contaminated with petroleum oils</li> <li>For services not listed contact Dixon™ for recommendations</li> </ul>
<b>Temperature:</b>	• -31°C to 80°C (-24°F to 176°F)
<b>Colour Code:</b>	<ul style="list-style-type: none"> <li>Black Buna with orange stripe; white Buna is all white</li> <li>Check gasket colour code to be certain it is recommended for the service intended</li> </ul>
<b>Specification:</b>	• Use lubricant on gasket

Size (inch)	Size (mm)	Black Buna with Orange Stripe Part #	White Buna Part #
1½	48	G150T	---
2	60	G200T	---
2½	73	G250T	---
3	89	G300T	---
4	114	G400T	G400N
5	127	G500T	---
6	168	G600T	---
8	219	G800T	---
10	273	G1000T	---
12	323	G1200T	---



Not for use in hot water services.

## Gasket Lube - Roll Grooved Couplings

F



<b>Application:</b>	<ul style="list-style-type: none"> <li>Specifically formulated where rubber gaskets are fitted especially in hot, dry, and wet weather. Also used in areas where high levels of water quality are not required such as sewerage, irrigation, and fire control systems. A consistently high quality of jointing is achieved. Incorrect lubricants, such as grease, can affect the life and effectiveness of a rubber gasket and also prevent correct positioning of the gasket, which can cause joint leakage.</li> </ul>
<b>Properties:</b>	<ul style="list-style-type: none"> <li>Water soluble emulsion. Excess lubricant is quickly removed from pipe systems when the system is flushed</li> <li>No detrimental effect on the natural synthetic rubbers used in gasket materials</li> <li>Jointing lubricant</li> <li>It contains an approved bactericide, which makes it safe to use with potable water</li> </ul>
<b>Standards:</b>	<ul style="list-style-type: none"> <li>AS 4020-1999</li> <li>Accredited under the Watermark Scheme MP 52 Spec 014. Licence No. W104</li> </ul>

**Part No.**

FFS-RGLUBE

## Long Pipe Style Nipples - Series AN

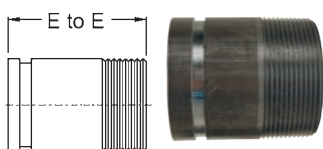

Groove x NPT Size		Dimensions E to E		Carbon Steel Part No.
inch	mm	inch	mm	
2	60	4	114	A712
2½	73	4	114	A7125
3	89	4	114	A713
4	114	6	168	A714
5	127	6	168	A715
6	168	6	168	A716



G

Ball .....	268-277
Gate.....	278-282
Butterfly.....	283-285
Safety Check.....	286
Check.....	287-288
Globe .....	289-290
Needle.....	291-292
Relief.....	293
Strainers .....	294-295



## Brass Ball Valve Female x Female BSP - AGA Approved



Lever Handle

<b>Design:</b>	• Full bore, blow-proof stem
<b>End Connection:</b>	• Female x Female BSP/NPT
<b>Body Materials:</b>	• Nickel plated brass with stainless steel handle
<b>Seat &amp; Ball:</b>	• PTFE seat, seal and thrust washer; Chrome plated brass ball; Plated steel handle
<b>Temperature:</b>	• Maximum temperature: <b>186°C (366°F)</b> ; Pressure rating: <b>600 PSI WOG 150 PSI</b> working steam pressure
<b>Approvals:</b>	• Underwriters Listed
<b>Application:</b>	• Recommended for control of air, water, oil, and gas in hose or pipe lines

### Lever Handle \*

Size		BSP Part No.	NPT Part No.
inch	mm		
¼	6	FBV25B	FBV25
⅜	10	FBV38B	FBV38
½	15	FBV50B	FBV50
¾	20	FBV75B	FBV75
1	25	FBV100B	FBV100
1¼	32	FBV125B	FBV125
1½	40	FBV150B	FBV150
2	50	FBV200B	FBV200
2½	65	FBV250B	FBV250
3	80	FBV300B	FBV300
4	100	FBV400B	FBV400

\* Superseded model will be supplied while stock lasts - check with Dixon™ at time of order.

## 250 Lb. Steam Ball Valves



G

<b>Design:</b>	• Blow-proof stem
<b>End Connection:</b>	• Female x Female NPT, Also available in BSP
<b>Body Materials:</b>	• Bronze body; 316 stainless steel stem; multi-fill stuffing box ring; high-temperature MTFE stem packing; adjustable packing gland
<b>Seat &amp; Ball:</b>	• Multi-fill RPTFE seats; 316 stainless steel ball
<b>Temperature:</b>	• Maximum temperature: <b>232°C (450°F)</b>
<b>Application:</b>	• Recommended for use with fluids with widely varying temperatures and/or thermal expansion rates
<b>Specifications:</b>	• Pressure rating: <b>600 PSI; 250 PSI</b> saturated steam; vacuum service to 29 inches Hg

Size		Port	NPT Part No.
inch	mm		
½	15	full	BBV50ST
¾	20	standard	BBV75ST
1	25	standard	BBV100ST
2	50	standard	BBV200ST

## Safety Vented Ball Valves



Sliding Lock Mechanism

<b>Design:</b>	• Blow-proof stem
<b>End Connection:</b>	• Female x Female NPT, Also available in BSP
<b>Body Materials:</b>	• Bronze body; adjustable packing gland
<b>Seat &amp; Ball:</b>	• RTFE seats and stuffing box ring; chromium plated ball
<b>Temperature:</b>	• Maximum temperature: <b>232°C (450°F)</b>
<b>Application:</b>	• For air service only
<b>Specifications:</b>	• Pressure rating: <b>0-125 PSI</b> ; vent downstream air in accordance with OSHA regulation 1910.147 for pneumatic systems

Size		Port	NPT Part No.
inch	mm		
¼	6	full	BBV25LV
⅜	10	full	BBV38LV
½	15	full	BBV50LV
¾	20	standard	BBV75LV
1	25	standard	BBV100LV
1¼	32	standard	BBV125LV
1½	40	standard	BBV150LV
2	50	standard	BBV200LV

## Mini Ball Valves

<b>Design:</b>	• Blowout-proof stem with standard port <sup>1</sup>
<b>Body Materials:</b>	• Nickel plated brass body; PTFE seats, FKM stem seal
<b>Pressure Rating:</b>	• <b>450 PSI</b>
<b>Temperature:</b>	• Maximum temperature <b>166°C (330°F)</b>
<b>Approval:</b>	• Canadian Standard Association approved

Size		NPT Part No.	BSP Part No.
inch	mm		
¼	3	MBV12	MBV12B
¼	6	MBV25	MBV25B
¾	10	MBV38	MBV38B
½	15	MBV50	MBV50B

<sup>1</sup> Female x male available upon request.



Female x Female

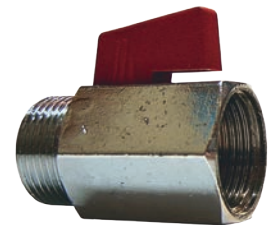

Male x Female

## Lockable Ball Valves

<b>Design:</b>	• Lever operated, C/W Locking device to lock open or closed; Blowout-proof stem
<b>End Connection:</b>	• Screwed Female BSP
<b>Body Materials:</b>	• Brass, chrome-plated brass ball and plated steel handle
<b>Seat &amp; Trim:</b>	• PTFE seats, seal, and thrust washer
<b>Temperature:</b>	• Maximum temperature: <b>186°C (366°F)</b>
<b>Application:</b>	• For control of air, water, oil, and gas in hose or pipe lines; for other services please contact Dixon™
<b>Specification:</b>	• Pressure ratings: <b>600 PSI WOG</b> ; <b>150 PSI</b> working steam pressure

Size		Port	NPT Part No.	BSP Part No.
inch	mm			
½	15	full	FBVL50	FBVL50B
¾	20	full	FBVL75	FBVL75B
1	25	full	FBVL100	FBVL100B
1¼	32	full	FBVL125	FBVL125B
1½	40	full	FBVL150	FBVL150B
2	50	full	FBVL200	FBVL200B
2½	65	full	FBVL250	FBVL250B
3	80	full	FBVL300	FBVL300B
4	100	full	FBVL400	FBVL400B



## "Deadman" Spring Return Handle Ball Valve



<b>Application:</b>	<ul style="list-style-type: none"> <li>Fail-safe closed valve where spillage can cause damage, injury, or loss if an operator incorrectly opens the valve</li> </ul>		
<b>Design:</b>	<ul style="list-style-type: none"> <li>Deadman spring return closes ball valve when not held open; Blowout-proof stem</li> </ul>		
<b>End Connection:</b>	<ul style="list-style-type: none"> <li>Screwed Female BSP x Female BSP ends</li> </ul>		
<b>Body Materials:</b>	<ul style="list-style-type: none"> <li>316 stainless steel, brass, chromium-plated ball</li> </ul>		
<b>Seat &amp; Trim:</b>	<ul style="list-style-type: none"> <li>PTFE seats and stuffing ring box</li> </ul>		
<b>Specifications:</b>	<ul style="list-style-type: none"> <li>Pressure rating: <b>600 PSI WOG</b>; <b>150 PSI</b> saturated steam</li> <li>Vacuum service to 29 inches Hg</li> <li>Operating torque approximately three times standard valve torque</li> <li>Full port on ½"; Standard port on larger sizes</li> </ul>		
Size		WP WOG PSI	Brass Part No.
inch	mm		
½	15	<b>1000</b>	BBV50SR
¾	20	<b>1000</b>	BBV75SR
1	25	<b>1000</b>	BBV100SR
1½	40	<b>1000</b>	BBV150SR
2	50	<b>1000</b>	BBV200SR

Available on request in 316 stainless steel.

## ANSI Ball Valve - Petro-Chemical - Fire Safe Certified

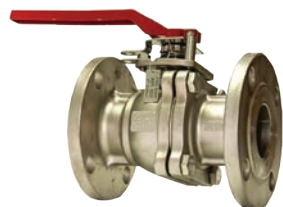

316 stainless steel



cast steel

<b>Applications:</b>	<ul style="list-style-type: none"> <li>Petroleum, oil and gas, low-pressure saturated steam, mining, and industrial applications</li> </ul>
<b>Design:</b>	<ul style="list-style-type: none"> <li>Fire safe certified ball valves flanged ANSI 150 to API607</li> </ul>
<b>End Connection:</b>	<ul style="list-style-type: none"> <li>Flanged and drilled ANSI 150</li> </ul>
<b>Body Materials:</b>	<ul style="list-style-type: none"> <li>Cast steel (ASTM A216 WCB) and stainless steel (CF8M - 316 stainless steel)</li> </ul>
<b>Seat &amp; Trim:</b>	<ul style="list-style-type: none"> <li>Ball - ASTM A351 CF8M; seat - R-PTFE</li> </ul>
<b>Pressure:</b>	<ul style="list-style-type: none"> <li><b>285 PSI</b> for water, oil, gas, and some corrosive fluids</li> </ul>
<b>Options:</b>	<ul style="list-style-type: none"> <li>ANSI class 300 &amp; 600 in WCB &amp; CF8M available on request</li> </ul>
<b>Accessories:</b>	<ul style="list-style-type: none"> <li>Gear operated, electric, and pneumatic actuated</li> </ul>
<b>Features:</b>	<ul style="list-style-type: none"> <li>Fire safe certified with lockable levers, 3.1 test certificates available on request</li> </ul>

### API 607 Fire Safe Certified ANSI 150 Ball Valves

Size NB		316SS (CF8M) Part No.	Cast Steel (WCB) Part No.
inch	mm		
½	15	V2FH-015	V2FH-WCB-015
¾	20	V2FH-020	V2FH-WCB-020
1	25	V2FH-025	V2FH-WCB-025
1¼	32	V2FH-032	V2FH-WCB-032
1½	40	V2FH-040	V2FH-WCB-040
2	50	V2FH-050	V2FH-WCB-050
2½	65	V2FH-065	V2FH-WCB-065
3	80	V2FH-080	V2FH-WCB-080
4	100	V2FH-100	V2FH-WCB-100
6	150	V2FH-150	V2FH-WCB-150

Available on request  
 - ANSI Class 300 in 316SS  
 - ANSI Class 150 in  
 - ANSI 300 in cast steel

## ANSI 150 & Table E Ball Valves

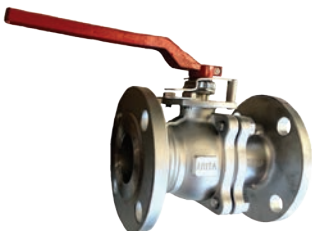

<b>Design:</b>	<ul style="list-style-type: none"> <li>Stainless steel ball valve flanged ANSI 150 lever operated</li> </ul>
<b>End Connection:</b>	<ul style="list-style-type: none"> <li>Flanged and drilled to ANSI 150LB / un-drilled / Table D/E</li> </ul>
<b>Body Materials:</b>	<ul style="list-style-type: none"> <li>CF8M (SS316), SS ball</li> </ul>
<b>Seat &amp; Trim:</b>	<ul style="list-style-type: none"> <li>PTFE seat</li> </ul>
<b>Pressure:</b>	<ul style="list-style-type: none"> <li>ANSI 150 is <b>285 PSI</b> for water, oil and gas, and corrosive fluids</li> </ul>
<b>Accessories:</b>	<ul style="list-style-type: none"> <li>Gear operated, electric, and pneumatic actuated</li> </ul>

Size NB		ANSI 150 Drilled	Drilled Table D/E
inch	mm	Part No.	Part No.
½	15	V2F-150-015	---
¾	20	V2F-150-020	---
1	25	V2F-150-025	---
1¼	32	V2F-150-032	---
1½	40	V2F-150-040	---
2	50	V2F-150-050	V2F-150DR-050
2½	65	V2F-150-065	V2F-150DR-065
3	80	V2F-150-080	V2F-150DR-080
4	100	V2F-150-100	V2F-150DR-100
6	150	V2F-150-150	V2F-150DR-150
8	200	V2F-150-200	---

Available on request  
 - Table E drilled valves ½" to 6"



## Class 800 Fire Safe Forged Steel Ball Valve - BSP & NPT

<b>Application:</b>	• Petroleum, oil and gas, low-pressure saturated steam, mining and industrial applications
<b>Design:</b>	• Class 800 forged steel BS5351, API 598, ASME B1.20.1
<b>End Connection:</b>	• Screwed Female: BSP, NPT, and Socket Weld
<b>Body Materials:</b>	• 3-piece forged steel - ASTM A 105N
<b>Seat &amp; Trim:</b>	• R-PTFE, Ball-304 stainless steel, Stem-A276 420
<b>Pressure/Temp:</b>	• <b>1975 PSI CWP: -29°C to 150°C (-20°F to 302°F)</b>
<b>Options:</b>	• Socket weld in forged steel, NPT valves in 316 stainless steel
<b>Features:</b>	• Full bore
<b>Other:</b>	• Class 1500 available in NPT



#800 A105N 3-Piece Ball Valve					
Size		Working Pressure		BSP	NPT
inch	mm	PSI	MPa	Part No.	Part No.
½	15	1975	13.6	FSBVB-015	FSBVN-015
¾	20	1975	13.6	FSBVB-020	FSBVN-020
1	25	1975	13.6	FSBVB-025	FSBVN-025
1¼	32	1975	13.6	FSBVB-032	FSBVN-032
1½	40	1975	13.6	FSBVB-040	FSBVN-040
2	50	1975	13.6	FSBVB-050	FSBVN-050

## Fire Safe Ball Valve - 2000 PSI SS 316

<b>Application:</b>	• Petroleum, oil and gas, mining, and general services
<b>Design:</b>	• 316 stainless steel 3-piece, full bore-ASME B16.34 fire safe certified API 607
<b>End Connection:</b>	• Screwed female: BSP, NPT and socket weld
<b>Body Materials:</b>	• 316 stainless steel - ASTM A351 CF8M
<b>Seat &amp; Trim:</b>	• R-PTFE (25% carbon fibre), ball-316 stainless steel, stem-A276 316
<b>Pressure/Temp:</b>	• <b>2000 PSI CWP: -29°C to 180°C (-20°F to 356°F)</b>
<b>Options:</b>	• Pneumatic and electric actuation can be fitted and supplied
<b>Features:</b>	• Full bore, ISO top, and locking lever
<b>Other:</b>	• Available on request - socket weld end connection. Valves can be retro-fitted with actuators



Fire Safe Certified - 2000 PSI 316 Stainless Steel 3 Piece API 607 Ball Valve					
Size		Working Pressure		BSP	NPT
inch	mm	PSI	MPa	Part No.	Part No.
½	15	2000	13.8	SS3PFSB-015	SS3PFSN-015
¾	20	2000	13.8	SS3PFSB-020	SS3PFSN-020
1	25	2000	13.8	SS3PFSB-025	SS3PFSN-025
1¼	32	2000	13.8	SS3PFSB-032	SS3PFSN-032
1½	40	2000	13.8	SS3PFSB-040	SS3PFSN-040
2	50	2000	13.8	SS3PFSB-050	SS3PFSN-050



## Stainless Steel One-Piece Ball Valve



<b>Application:</b>	• For use with water, oil, and gas
<b>Design:</b>	• Standard full port; Blowout-proof stem design
<b>End Connection:</b>	• Female NPT or BSP
<b>Body Materials:</b>	• 316 stainless steel body, ball, and stem
<b>Seat &amp; Trim:</b>	• PTFE seat, joint gasket, and thrust washer
<b>Pressure:</b>	• ¼" - 2" rated to <b>1000 PSI</b> WOG (CWP) ; 2½" - 3" rated to <b>800 PSI</b> WOG (CWP) • <b>100 PSI</b> saturated steam
<b>Temperature:</b>	• <b>-29°C to 230°C (-20°F to 446°F)</b> as long as the valve is run fully open/closed

Size <sup>1</sup>		BSP Part No.	NPT Part No.
inch	mm		
¼	6	SSBV25B	SSBV25
⅜	10	SSBV38B	SSBV38
½	15	SSBV50B	SSBV50
¾	20	SSBV75B	SSBV75
1	25	SSBV100B	SSBV100
1¼	32	SSBV125B	SSBV125
1½	40	SSBV150B	SSBV150
2	50	SSBV200B	SSBV200
2½	65	SSBV250B	SSBV250
3	80	SSBV300B	SSBV300

## Two Piece SS Ball Valve



<b>Application:</b>	• For use with air, water, oil, gas, and most chemicals, locking device standard
<b>Design:</b>	• Full bore
<b>End Connection:</b>	• Female x female BSP/NPT
<b>Body Materials:</b>	• 316 stainless steel
<b>Seat &amp; Trim:</b>	• PTFE seat
<b>Pressure:</b>	• 15mm to 40mm rated to <b>800 PSI</b> • 50mm rated to <b>600 PSI</b>

Size <sup>1</sup>		BSP Part No.	NPT Part No.
inch	mm		
¼	6	G2/025SS	G2/025SS-NPT
⅜	10	G2/038SS	G2/038SS-NPT
½	15	G2/050SS	G2/050SS-NPT
¾	20	G2/075SS	G2/075SS-NPT
1	25	G2/100SS	G2/100SS-NPT
1¼	32	G2/125SS	G2/125SS-NPT
1½	40	G2/150SS	G2/150SS-NPT
2	50	G2/200SS	G2/200SS-NPT

<sup>1</sup> Larger sizes available upon request.

## Three-Piece SS Ball Valve



Pneumatic or electrical actuation available.

<b>Application:</b>	• For use with air, water, oil, gas, and most chemicals. Locking device standard
<b>Design:</b>	• Full bore
<b>End Connection:</b>	• Female x female NPT - Various end connections available upon request
<b>Body Materials:</b>	• 316 stainless steel
<b>Seat &amp; Trim:</b>	• PTFE seat
<b>Pressure:</b>	• 15mm to 40mm rated to <b>800 PSI</b> • 50mm to 100mm rated to <b>600 PSI</b>

Size <sup>1</sup>		BSP Part No.	NPT Part No.
inch	mm		
¼	6	G3/025SS	G3/025SS-NPT
⅜	10	G3/038SS	G3/038SS-NPT
½	15	G3/050SS	G3/050SS-NPT
¾	20	G3/075SS	G3/075SS-NPT
1	25	G3/100SS	G3/100SS-NPT
1¼	32	G3/125SS	G3/125SS-NPT
1½	40	G3/150SS	G3/150SS-NPT
2	50	G3/200SS	G3/200SS-NPT

<sup>1</sup> Larger sizes available upon request.

### 3-Way 'L' Port Ball Valve

<b>Application:</b>	• For use with gasoline and diesel fuel
<b>Design:</b>	• Lever-operated anti-static device with Blowout-proof stem, ASTM A351-CF8M. ISO 5211
<b>End Connection:</b>	• Female x female x female NPT/BSP
<b>Body Material:</b>	• Bronze; chromium-plated ball; stainless steel handle and nut; vinyl sleeve
<b>Seat &amp; Trim:</b>	• Trim: 316 stainless steel; Seats and stuffing box ring: RPTFE
<b>Pressure:</b>	• Pressure rating: <b>400 PSI</b> WOG

Bronze				
Size		Port	NPT Part No.	BSP Part No.
inch	mm			
½	15	full	BB3WL012 <sup>1</sup>	BB3WL012B
¾	20	standard	BB3WL020	BB3WL020B
1	25	standard	BB3WL025	BB3WL025B

<sup>1</sup> Carbon steel handle and nut with vinyl sleeve

<b>Application:</b>	• For use with air, water, oil, and gas
<b>Design:</b>	• Lever-operated anti-static device with Blowout-proof stem, ASTM A351-CF8M. ISO 5211
<b>End Connection:</b>	• Female x Female x Female NPT/BSP
<b>Body Material:</b>	• Stainless steel body and ball; stainless steel handle and nut; vinyl sleeve
<b>Seat &amp; Trim:</b>	• Trim: 316 stainless steel; Seats and stuffing ring box: RPTFE
<b>Pressure:</b>	• Rated to <b>800 PSI</b> WOG
<b>Approval:</b>	• Meets NACE MR-01-75

Stainless Steel				
Size		Port	NPT Part No.	BSP Part No.
inch	mm			
½	15	full	SS3WL012	SS3WL012B
¾	20	standard	SS3WL020	SS3WL020B
1	25	standard	SS3WL025	SS3WL025B



Pneumatic or electrical actuation available.

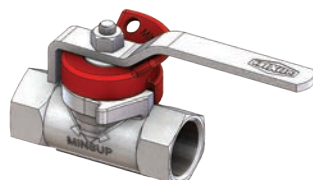
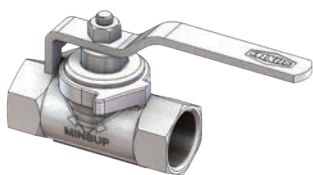

**Econovalves™ - Ball Valves****minsip**

3/4" &amp; 1" BSPF RANGE

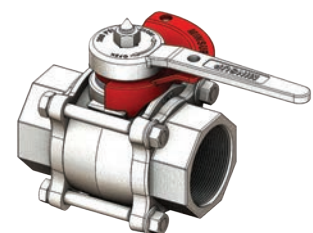
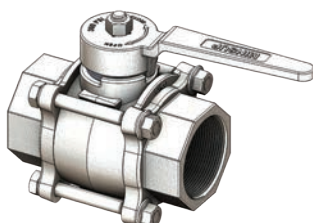

1 1/2" &amp; 2" BSPF RANGE

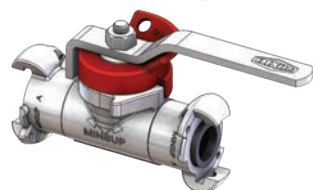
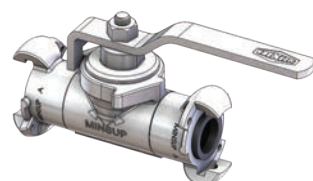

<b>Application:</b>	• General-purpose ball valve suitable for mining and industrial applications
<b>Design:</b>	• Solid construction with unique one-piece ball and stem provides positive on/off action. In-line maintenance is easy for the top loading 3/4" and 1" range, and the 3-piece 1 1/2" and 2" range
<b>Body Materials:</b>	• Spheroidal graphite-cast iron to ISO 1083; 400-250-15 SGI
<b>Seals:</b>	• Nitrile butadiene
<b>Handle:</b>	• Spheroidal graphite-cast iron to ISO 1083 (1 1/2" - 2") • All other sizes have pressed mild steel handles
<b>Ball &amp; Stem:</b>	• Spheroidal graphite cast iron to ISO 1083 • Chrome copper plated to AS1192
<b>Seats &amp; Trim:</b>	• Nitrile butadiene
<b>Bolts:</b>	• Hex, M10 x 1.5 x 90, Grade 8.8, black
<b>Nuts:</b>	• Hex, M10 x 1.5, zinc plated, Grade 8
<b>Temperature:</b>	• <b>-20° to 80°C (-4°F to 176°F)</b>
<b>Options:</b>	• Refer econovalve lockout device 419
<b>Working Pressure:</b>	• 1/2 to 1" = <b>500 PSI WP</b> • 1 1/2 to 2" = <b>300 PSI WP</b>

**BSP Female x BSP Female**

Size (inch)	Part No.	
	Standard	Lockout
1/2	---	08/062/03/000
3/4	---	08/062/114/00LO
1	08/062/113/00	08/062/113/00LO
1 1/2	---	08/062/847/00LO
2	08/062/848/00	08/062/848/00LO
NPTF x NPTF Standard		
1	08/062/102/00	08/062/102/00LO

**'A' Type x 'A' Type**

Size (inch)	Part No.	
	Standard	Lockout
1	08/062/110/00	08/062/110/00LO

G

## Econovalves™ - Ball Valves



1" BSP Female x 'A' Type		
Size (inch)	Part No.	Part No.
	Standard	Lockout
1	08/062/104/00	08/062/104/00LO

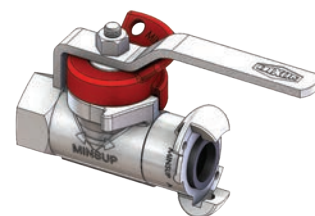
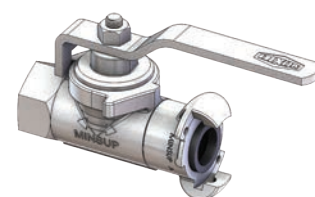

1" BSP Female x 2" Shouldered		
Size (inch)	Part No.	Part No.
	Standard	Lockout
1	08/062/118/00	08/062/118/00LO

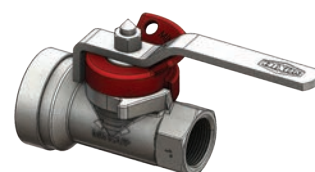

Female Thread x Surelock	
Size (inch)	Part No.
Lockout	
To suit Surelock sizes 3/8" - 1/4"	
1 (BSP)	08/062/172/00LO
1 (NPT)	08/062/108/00LO
To suit Surelock sizes 1 1/2" - 2"	
2 (BSP)	08/062/868/00LO

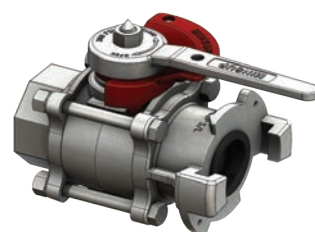
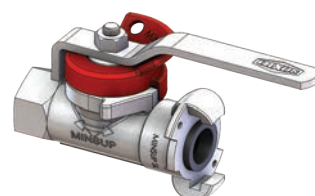

**Econovalves™ with Lockout Device - Ball Valves****minsip**

BSP Female x Shouldered	
Size (inch)	Part No.
Lockout	
2	08/062/56/00LO

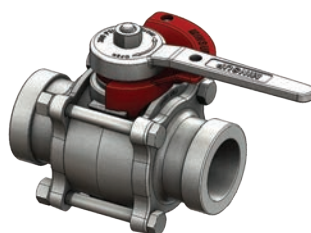

Shouldered x Shouldered	
Size (inch)	Part No.
Lockout	
2	08/062/849/00LO

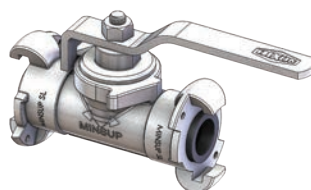

Surelock x Surelock		
Size (inch)	Part No.	Part No.
	Standard	Lockout
To suit Surelock sizes 3/8" - 1 1/4"		
1 (BSP)	08/062/111/00	08/062/111/00LO

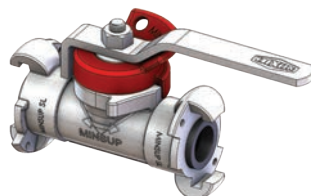

1" RANGE

G

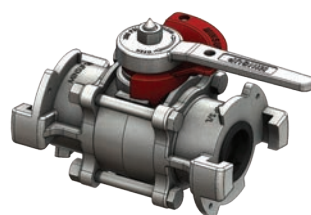

1 1/2" - 2" RANGE

Surelock x Surelock	
Size (inch)	Part No.
Lockout	
To suit Surelock sizes 1 1/2" - 2"	
1 (BSP)	08/062/869/00LO

## Minsup™ Econo Valve™ Ball Valve Lockout Device



<b>Design:</b>	• Designed to retrofit all existing Minsup™ Econo Valve™ configurations; easy to install; lock open / lock closed
<b>Body Materials:</b>	• SG Iron ISO 1083, 1987: 400-250-15
<b>Approvals:</b>	• Design registration: 200614656

Size (inch)	Part No.	Description
1	ELOK100C	For ¾" and 1" configurations
2	ELOK200C	For 1½" and 2" configurations



ELOK100C



ELOK200C

## Mining Brass Water Valves (Bendigo Valve)



<b>Application:</b>	• Mine water valves, or bendigo taps, protect air leg rock drills from dirty mine water utilising a filter mesh to ensure tools are protected from foreign matter
<b>End Connection:</b>	• ½" BSP male
<b>Body Materials:</b>	• Brass
<b>Features:</b>	• A forged body

Size	Part No.
½" (15mm) Male/Male	05/062/01/000



## GP Gate Valves

<b>Application:</b>	• For pumping, irrigation, light industrial, and domestic and rural services
<b>Design:</b>	• Iron handwheel, adjustable packing nut, integral seat
<b>End Connection:</b>	• Screwed female BSP
<b>Body Materials:</b>	• Brass, non-rising stem
<b>Wedge:</b>	• Brass solid wedge disc
<b>Pressure:</b>	• Pressure rating: <b>200 PSI</b> non-shock cold water, oil, gas

Size (inch)	Size (mm)	Brass		Stainless Steel	
		NPT Part No.	BSP Part No.	NPT Part No.	BSP Part No.
¼	6	BGV25	---	---	---
⅜	10	BGV38	GV038BH	---	---
½	15	BGV50	GV050BH	SSGV50	SSGV50B
¾	20	BGV75	GV075BH	SSGV75	SSGV75B
1	25	BGV100	GV100BH	SSGV100	SSGV100B
1¼	32	BGV125	GV125BH	SSGV125	SSGV125B
1½	40	BGV150	GV150BH	SSGV150	SSGV150B
2	50	BGV200	GV200BH	SSGV200	SSGV200B
2½	65	BGV250	GV250BH	---	---
3	85	BGV300	GV300BH	---	---
4	100	BGV400	GV400BH	---	---



brass



316 stainless



## Class 800 Forged Steel Gate - BSP & NPT



<b>Application:</b>	• Can be used for steam service
<b>Design:</b>	• Class 800; ASTM A105; ANSI B120.1
<b>End Connection:</b>	• Screwed Female: BSP or NPT
<b>Body Materials:</b>	• Forged steel - ASTM A 105N
<b>Seat &amp; Trim:</b>	• Seat- ASTM A276 420, wedge and stem- ASTM A182 F6a
<b>Pressure/Temp:</b>	• <b>1975 PSI</b> ; maximum temperature <b>427°C (800°F)</b>
<b>Options:</b>	• Socket weld in forged steel, 316 stainless steel available in screwed NPT
<b>Features:</b>	• OS&Y, bolted bonnet, F/bore, solid wedge
<b>Other:</b>	• Class 1500 available in NPT ends

**#800 A105N Gate Valve**

Size (inch)	Size (mm)	Working Pressure		BSP	NPT
		PSI	MPa	Part No.	Part No.
½	15	<b>1975</b>	13.6	FSGVB-015	FSGVN-015B
¾	20	<b>1975</b>	13.6	FSGVB-020	FSGVN-020B
1	25	<b>1975</b>	13.6	FSGVB-025	FSGVN-025B
1¼	32	<b>1975</b>	13.6	FSGVB-032	FSGVN-032B
1½	40	<b>1975</b>	13.6	FSGVB-040	FSGVN-040B
2	50	<b>1975</b>	13.6	FSGVB-050	FSGVN-050B

## Monitored Grooved Gate Valves

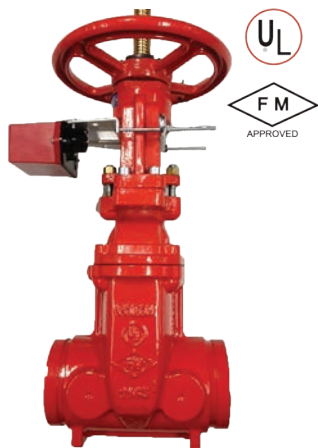

<b>Application:</b>	• Suitable for applications where valves with supervisory switches are required e.g. fire distribution services
<b>Design:</b>	• Rising stem OS&Y gate valve with class B switches
<b>End Connection:</b>	• Roll grooved
<b>Body Materials:</b>	• Ductile iron with resilient wedge
<b>Mon Device:</b>	• Class B - Potter - UL / FM

Face to Face Dim	Size NB (mm)	Pipe OD (mm)	Part No.
203	80	88.9	VG172-OSYG80ATS
229	100	114.3	VG172-OSYG100ATS
267	150	165.1	VG172-OSYG150ATS
292	200	219.1	VG172-OSYG200ATS

Note: Supplied in kit form for assembly at site

## Grooved Gate Valves Fig F0122-200

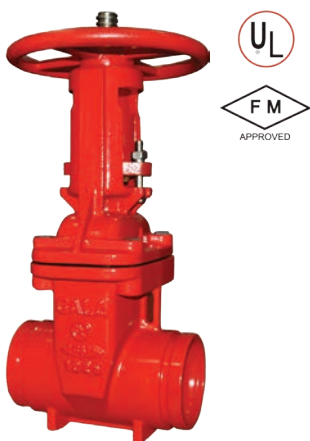

<b>Application:</b>	• For fire protection and distribution services, water, sewerage, and neutral liquids
<b>Design:</b>	• Resilient seated EPDM encapsulated wedge OS&Y
<b>Body Materials:</b>	• Ductile iron
<b>Pressure:</b>	• Max working pressure 1400/1600 kPa at <b>-0.6°C to 52°C (30°F to 125°F)</b>

Face to Face Dim	Size NB (mm)	Pipe OD (mm)	Part No.
191	80	88.9	VG172-OSY-G80
229	100	114.3	VG172-OSY-G100
267	150	165.1	VG172-OSY-G150
292	200	219.1	VG172-OSY-G200
356	250	273	VG172-OSY-G250



## Shouldered Gate Valves Fig GVNR-S-1161

<b>Application:</b>	• Water and slurry applications - mining
<b>Design:</b>	• Non-rising stem gate valve, shoulder dimensions are made in accordance with metric pipe
<b>End Connection:</b>	• Shouldered
<b>Body Materials:</b>	• Ductile iron body, stainless steel stem, bronze seat
<b>Wedge:</b>	• Cast iron wedge
<b>Approvals:</b>	• Conforms to BS5150 - PN20 rated

Face to Face Dim	Size NB (mm)	Part No.
229	100	GVNR-S-1161-100
267	150	GVNR-S-1161-150



## Monitored Gate Valves Table E, Ductile Iron Flanged Fig F0111-200

<b>Application:</b>	• For water, sewerage, and neutral liquids. Bubble tight shut off. Suitable for fire protection and distribution services. Valves with supervisory switches are required e.g. fire distribution services.
<b>Design:</b>	• OS&Y Gate Valve
<b>End Connection:</b>	• Flanged, Table D/E, AS2129
<b>Body Materials:</b>	• Ductile Iron, ASTM A126 Class B
<b>Wedge:</b>	• Resilient seated EPDM encapsulated wedge
<b>Temperature:</b>	• Pressure temperature rating 1400/ 1600kPa @ 0.6°C to 52°C (33°F to 125°F)
<b>Approvals:</b>	• UL/FM approved
<b>Mon Device:</b>	• Class B - Potter - UL / FM - Standard
<b>Options:</b>	• Australian standard, Switch

Face to Face Dim	Size NB (mm)	Part No.
229	100	VG172-OSYE100ATS
267	150	VG172-OSYE150ATS
292	200	VG172-OSYE200ATS
330	250	VG172-OSYE250ATS
356	300	VG172-OSYE300ATS

Note: Supplied in kit form for assembly at site.



## Gate Valves Fig GVRC-1161

<b>Application:</b>	• Water, oil, and gas
<b>Design:</b>	• OS&Y gate valve
<b>End Connection:</b>	• Flanged, AS2129 Table D/E
<b>Body Materials:</b>	• Cast iron body with wedge, bronze seat
<b>Temperature:</b>	• Pressure temperature rating 1600kPa at -10°C to 120°C (14°F to 248°F)
<b>Approvals:</b>	• Conforms to BS5150, MSS SP-70, flange conforms to BS 4504 PN 16, ANSI 125 and drilled to Table E

Face to Face Dim	Size NB (mm)	Part No.
190	65	GVRC1161-065
203	80	GVRC1161-080
229	100	GVRC1161-100E
229	100	GVRC1161-100D
267	150	GVRC1161-150
292	200	GVRC1161-200
330	250	GVRC1161-250
356	300	GVRC1161-300

Note: Sizes 350-600 available on request.



## NRS Gate Valves Fig 3243



<b>Application:</b>	• For water, sewerage, and neutral liquids
<b>Design:</b>	• Non-rising stem gate valve
<b>End Connection:</b>	• Flanged, drilled Table E, AS2129
<b>Body Materials:</b>	• Ductile iron body, stainless steel stem, fusion bonded epoxy coated
<b>Wedge:</b>	• Resilient wedge - EPDM encapsulated
<b>Temperature:</b>	• 16 bar pressure rated at <b>-10°C to 120°C (14°F to 248°F)</b>
<b>Approvals:</b>	• Designed and tested to BS5163

Face to Face Dim	Size NB (mm)	Part No.
191	65	GVNR-RW-1161-65
203	80	GVNR-RW-1161-80
229	100	GVNR-RW-1161-100
267	150	GVNR-RW-1161-150
292	200	GVNR-RW-1161-200
330	250	GVNR-RW-1161-250
356	300	GVNR-RW-1161-300

## Ductile Iron Flanged Gate Valves Fig F0111-200



<b>Application:</b>	• For water, sewerage, and neutral liquids, bubble tight shut off, suitable for fire protection and distribution services
<b>Design:</b>	• OS&Y Gate Valve
<b>End Connection:</b>	• Flanged, Table D/E, AS2129
<b>Body Materials:</b>	• Ductile Iron, A53665-45-12
<b>Wedge:</b>	• EPDM encapsulated wedge, resilient seated
<b>Temperature:</b>	• Pressure temperature rating 1400/ 1600kPa @ <b>0.6°C to 52°C (33°F to 125°F)</b>
<b>Approvals:</b>	• UL/FM approved

Face to Face Dim	Size NB (mm)	Part No.
190	65	VG172-OSY-E65
203	80	VG172-OSY-E80
229	100	VG172-OSY-D100
229	100	VG172-OSY-E100
267	150	VG172-OSY-E150
292	200	VG172-OSY-E200
330	250	VG172-OSY-E250
356	300	VG172-OSY-E300

## Stainless Steel OS&Y Gate Valves



<b>Design:</b>	• To API 603 / ASME B1634
<b>End Connection:</b>	• Flanged ANSI 150LB is standard
<b>Body Materials:</b>	• 316 stainless steel (CF8M)
<b>Pressure:</b>	• <b>285 PSI</b> for water, oil and gas, and corrosive fluids
<b>Options:</b>	• Available on request: - drilled table D/E up to 150NB - 316 stainless steel valves drilled to table E - cast steel in 150# and 300# ANSI

Size NB (mm)	Part No.
65	VGA-150-065
80	VGA-150-080
100	VGA-150-100
150	VGA-150-150
200	VGA-150-200
250	VGA-150-250
300	VGA-150-300

## ANSI 150 Cast Steel Gate Valves - API 600

<b>Application:</b>	• Petro-chemical, oil and gas, mining, power, and general services
<b>Design:</b>	• ANSI 150 cast steel, OS&Y - ASME B16.34 & API 600
<b>End Connection:</b>	• Flanged ANSI 150#
<b>Body Materials:</b>	• Cast steel - ASTM A105
<b>Seat &amp; Trim:</b>	• Seat ring - 2Cr13, stem - 2Cr13, disc - 2Cr13 + STL
<b>Pressure/Temp:</b>	• <b>285 PSI CWP</b>
<b>Options:</b>	• Sizes in ½" to 1½" ANSI 150 also available on request
<b>Features:</b>	• OS&Y, bolted bonnet, full bore, solid wedge
<b>Other:</b>	• ANSI 300 and 600 also available in gate, globe, and check valves

Cast Steel Gate Valve ANSI 150					
Size		Flange	CWP	WP	Part No.
inch	mm		PSI	MPa	
2	50	ANSI 150	<b>285</b>	1.965	VGA-CS-150-050
2½	65	ANSI 150	<b>285</b>	1.965	VGA-CS-150-065
3	80	ANSI 150	<b>285</b>	1.965	VGA-CS-150-080
4	100	ANSI 150	<b>285</b>	1.965	VGA-CS-150-100
6	150	ANSI 150	<b>285</b>	1.965	VGA-CS-150-150
8	200	ANSI 150	<b>285</b>	1.965	VGA-CS-150-200
10	250	ANSI 150	<b>285</b>	1.965	VGA-CS-150-250
12	300	ANSI 150	<b>285</b>	1.965	VGA-CS-150-300



## Post Indicator Flanged Gate Valves Fig F0211-200

<b>Application:</b>	• Fire protection and distribution services, water, sewerage, and neutral liquids
<b>Design:</b>	• Design and dimensions to AWWA C509
<b>End Connection:</b>	• Flanged table E AS2129 or ANSI 125
<b>Body Materials:</b>	• Cast iron body, ASTM A126 CL. B
<b>Wedge:</b>	• Resilient seated wedge, EPDM encapsulated
<b>Pressure:</b>	• Maximum working pressure 1,400 kPa @ <b>0.6°C to 52°C (33°F to 125°F)</b>
<b>Approvals:</b>	• UL/FM approved
<b>Options:</b>	• Other flanges available on request

Face to Face Dim	Size NB (mm)	Part No.
190	65	VF-GVNR-RW-065E
203	80	VF-GVNR-RW-080E
229	100	VF-GVNR-RW-100E
267	150	VF-GVNR-RW-150E
292	200	VF-GVNR-RW-200E
330	250	VF-GVNR-RW-250E
356	300	VF-GVNR-RW-300E
---	65-300 post	VF-PI

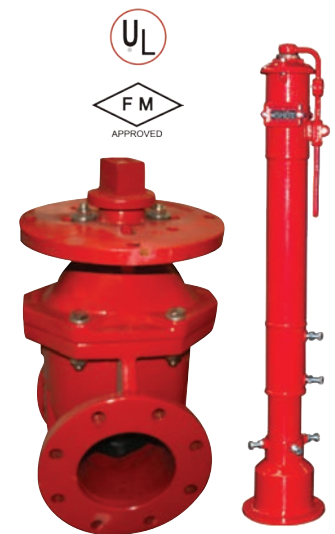

## Sluice Gate Valves



<b>Application:</b>	• Fabricated T handle valve key used to open spindle cap operated sluice valves that are installed in points in the ground. These keys can be fabricated to customer requirements if required.
<b>Design:</b>	• Spindle cap operated and clockwise closing, bubble tight shut off
<b>End Connection:</b>	• Flanged Table D, AS2129
<b>Body Materials:</b>	• Ductile iron flange, FBE coated body
<b>Wedge:</b>	• EPDM encapsulated wedge, resilient seated to AS 2638.2
<b>Temperature:</b>	• Pressure temperature. Rating 1,600 kPa at <b>70°C (158°F)</b>
<b>Approvals:</b>	• Certified to AS2638.2
<b>Options:</b>	• Hand wheel and anti-clock closing

Face to Face Dim	Size NB (mm)	Part No.
203	80	V57SV-80
229	100	V57SV-100
267	150	V57SV-150
292	200	V57SV-200
330	250	V57SV-250
356	300	V57SV-300
<b>T Handle Valve Key</b>		
-	-	FKG-VK

Note: Hand wheels and T handle sold separately

## Hand Wheels for AS2638.2 Sluice/Gate Valves



<b>Application:</b>	• Suit AS2638.2 sluice/gate valve
<b>Material:</b>	• Ductile iron

Description	Part No.
80mm & 100mm	V57SVHW-100
150mm	V57SVHW-150
200mm	V57SVHW-200
250mm & 300mm	V57SVHW-300

G

## Knife Gate Valves



Full SS 316 Body  
Lugged Table D

Cast Iron Body  
Semi-Lugged  
Table D/E



<b>Application:</b>	• Water, slurry, sewerage, etc.
<b>Design:</b>	• Knife gate valves are available in either full 316 stainless steel lugged, or cast iron body wafer/lugged
<b>End Connection:</b>	• Lugged Table D and wafer semi lugged table D/E
<b>Body Materials:</b>	• 316 stainless steel or cast iron
<b>Knife:</b>	• 316 stainless steel valve, cast iron is 304 stainless steel
<b>Pressure:</b>	• Rated to 10 bar (1,000 kpa)
<b>Seat:</b>	• Stainless steel valves standard seat is metal-to-metal, EPDM and FKM available, cast iron valves standard seat is NBR or EPDM

Size (mm)	Stainless Steel Lugged T/D	Cast Iron Body Wafer Semi-Lugged
	Part No.	Part No.
80	VKG-080-SS	VKG-080
100	VKG-100-SS	VKG-100
150	VKG-150-SS	VKG-150
200	VKG-200-SS	VKG-200
250	VKG-250-SS	VKG-250
300	VKG-300-SS	VKG-300

Note: Sizes up to 600mm available on request. Cylinders and electric actuators available on request.

## Minsup™ Shouldered Butterfly Valves



<b>Application:</b>	• Mining industry
<b>Design:</b>	• Lever-operated, corrosion-resistant, stainless steel disc and shaft • Lever can be padlocked out in any of 11 positions • Nitrile butadiene lining is moulded to the body • Disc has high flow coefficient design which minimises flow resistance and cavitation
<b>End Connection:</b>	• Shouldered
<b>Body Materials:</b>	• Body - SG Iron to ISO 1083; 400-250-15 • Lining - Nitrile butadiene - 70 Duro hardness • Disc - cast stainless steel Grade CF8M to ASTM A351 • Handle - SG Iron ISO 1083;400-250-15 • Shaft - Grade 316 stainless steel
<b>Seats &amp; Trim:</b>	• Nitrile butadiene lining
<b>Actuator:</b>	• Lever as standard
<b>Temperature:</b>	• Min: <b>-20°C (-4°F)</b> • Max: <b>60°C (140°F)</b>
<b>Pressure:</b>	• Water: 2000 kPa, <b>290 PSI</b> • Air: 1034 kPa, <b>150 PSI</b>
<b>Standards:</b>	• Shouldered ends in accordance with ANSI/AWWA C606 • Actuator mounting flange in accordance with AS5211
<b>Options:</b>	• Actuation available on request • Optional operators include manual gearbox and pneumatic actuator

Size NB (mm)	Face to Face Dimensions (mm)	Part No.
100	116	08/002/374/00
150	149	08/002/574/00

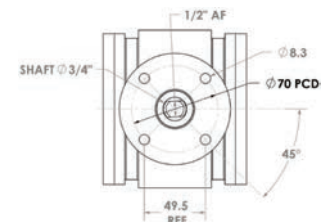

Mounting pads are the same on 100mm and 150mm Minsup™ valves.  
Handles and actuators will interchange between 100mm and 150mm Minsup™ valves.

## 316 Stainless Steel Wafer & Lugged Butterfly Valves

<b>Application:</b>	• Petro-chemical, oil and gas, marine, and industrial applications
<b>Design:</b>	• Butterfly valve, wafer and fully lugged, lever operated
<b>End Connection:</b>	• Wafer type fits between Table E, lugged valve is to AS2129 table E
<b>Body Materials:</b>	• 316 stainless steel (CF8M)
<b>Seats &amp; Trim:</b>	• Stem: 316 stainless steel, seat: PTFE ( EPDM encapsulated)
<b>Pressure:</b>	• PN10 or 1000KPA
<b>Options:</b>	• Lugged ANSI Class 150 available on request
<b>Accessories:</b>	• Gear operators, pneumatic and electric actuators
<b>Features:</b>	• ISO top for direct mounting of actuators and stainless steel lever and notch plate

Size NB (inch)	Size NB (mm)	Wafer Table E	Lugged Table E
		Part No.	Part No.
1 1/2	40	BFVW-SS-040	---
2"	50	BFVW-SS-050	BFVL-SS-050
2 1/2	65	BFVW-SS-065	BFVL-SS-065
3	80	BFVW-SS-080	BFVL-SS-080
4	100	BFVW-SS-100	BFVL-SS-100
6	150	BFVW-SS-150	BFVL-SS-150
8	200	BFVW-SS-200	BFVL-SS-200



Wafer



Lugged

## Threaded Lug Style Butterfly Valves



<b>Application:</b>	• For use between two 150 lb. flanges
<b>Design:</b>	• Wafer type; 10-position trigger grip handle; Pneumatic or electrical actuation available
<b>End Connection:</b>	• Wafer Table E standard, lugged to Table E optional
<b>Body Materials:</b>	• Ductile iron body; ASTM A536, PTFE bushing; stainless steel top and bottom stems; Aluminium bronze disc: ASTM B148, ALY.954

Size NB		Ductile Iron with Buna-N Liner	Ductile Iron with EPDM Liner
mm	inch	Part No.	Part No.
50	2	BFVL200	BFVL200E
85	3	BFVL300	BFVL300E
100	4	BFVL400	BFVL400E
150	6	BFVL600	BFVL600E

## Wafer Style 150 lb. Butterfly Valves with Aluminium Bronze Disc



<b>Application:</b>	• For use between two 150 lb. flanges
<b>Design:</b>	• Wafer type; 10-position trigger grip handle; Pneumatic or electrical actuation available
<b>End Connection:</b>	• Wafer Table E standard, lugged to Table E optional
<b>Body Materials:</b>	• Ductile iron body; ASTM A536, PTFE bushing; stainless steel top and bottom stems; aluminium bronze disc: ASTM B148, ALY.954

Size NB		Ductile Iron with Buna-N Liner	Ductile Iron with EPDM Liner
mm	inch	Part No.	Part No.
50	2	BBFVW200	BBFVW200E
85	3	BBFVW300	BBFVW300E
100	4	BBFVW400	BBFVW400E
150	6	BBFVW600	BBFVW600E

## Wafer Style 150 lb. Butterfly Valves with Stainless Disc



<b>Application:</b>	• For use between two 150 lb. flanges
<b>Design:</b>	• Wafer type; 10-position trigger grip handle; Pneumatic or electrical actuation available
<b>End Connection:</b>	• Wafer Table E standard, lugged to Table E optional
<b>Body Materials:</b>	• Ductile iron body; ASTM A536, PTFE bushing; stainless steel disc, ASTM A351, GR. CF-8M; Buna-N seal and stem seals, stainless steel top and bottom stems

Size NB		Ductile Iron with Buna-N Liner
mm	inch	Part No.
50	2	BFVW200
85	3	BFVW300
100	4	BFVW400
150	6	BFVW600

## Wafer Style 150 lb. Butterfly Valves with Iron Disc



<b>Application:</b>	• For use between two 150 lb. flanges
<b>Design:</b>	• Wafer type; 10-position trigger grip handle; Pneumatic or electrical actuation available
<b>End Connection:</b>	• Wafer Table E standard, lugged to Table E optional
<b>Body Materials:</b>	• Ductile iron body; ASTM A536, PTFE bushing; Nickel-plated iron disc, Buna-N seal and stem seals, 416 stainless steel stems

Size NB		Ductile Iron with Buna-N Liner	Ductile Iron with EPDM Liner
mm	inch	Part No.	Part No.
85	3	IBFVW300	IBFVW300E
100	4	IBFVW400	IBFVW400E
150	6	IBFVW600	IBFVW600E
200	8	IBFVW800	IBFVW800E

**200 PSI at ambient temperature 21°C (70°F). NOT RECOMMENDED FOR STEAM SERVICE.**

## Monitored Wafer Butterfly Valves Fig DW

<b>Application:</b>	• Designed to initiate a signal at appropriate supervisory equipment to show whether a valve is open or closed, suitable for fire protection and distribution systems
<b>Design:</b>	• Gear-operated monitored butterfly valve
<b>End Connection:</b>	• Fits between ANSI 125 and Table E flanges
<b>Body Materials:</b>	• Ductile iron body, A1 bronze disc, nickel chrome plated
<b>Seats &amp; Trim:</b>	• EPDM encapsulated
<b>Pressure:</b>	• <b>175 PSI</b>

Face to Face Dim	Part No.	Size NB (mm)
52	VFBFW-114-GEAR	100
56	VFBFW-165-GEAR	150
60	VFBFW-219-GEAR	200

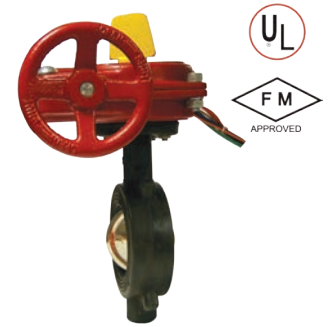

## Screwed BSP Bronze Monitored Butterfly Valves Fig BT

<b>Application:</b>	• Designed to initiate a signal at appropriate supervisory equipment to show whether a valve is open or closed, fire protection and distribution systems
<b>Design:</b>	• Gear-operated monitored butterfly valve
<b>End Connection:</b>	• Screwed BSP
<b>Body Materials:</b>	• A1 bronze disc
<b>Seats &amp; Trim:</b>	• EPDM encapsulated
<b>Pressure:</b>	• Max <b>175 PSI</b> at 0°C to 120°C (32°F to 248°F)

Face to Face Dim	Part No.	Size NB (mm)
54	VGBBB-34-GEAR	25
67	VGBBB-43-GEAR	32
73	VGBBB-48-GEAR	40
82.4	VGBBB-60-GEAR	50

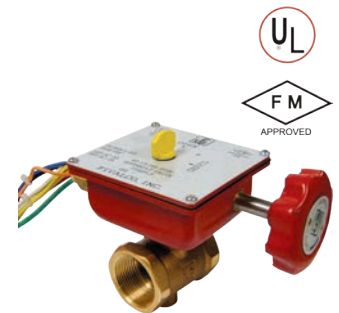

## Grooved Bronze Monitored Butterfly Valves Fig BG

<b>Application:</b>	• Designed to initiate a signal at appropriate supervisory equipment to show whether a valve is open or closed, suitable for fire protection and distribution systems
<b>Design:</b>	• Gear-operated monitored butterfly valve
<b>End Connection:</b>	• Grooved
<b>Body Materials:</b>	• A1 bronze disc
<b>Seats &amp; Trim:</b>	• EPDM encapsulated
<b>Pressure:</b>	• Max <b>175 PSI</b> at 0°C to 120°C (32°F to 248°F)

Face to Face Dim	Part No.	Size NB (mm)
114	VGBBF-60-GEAR	50

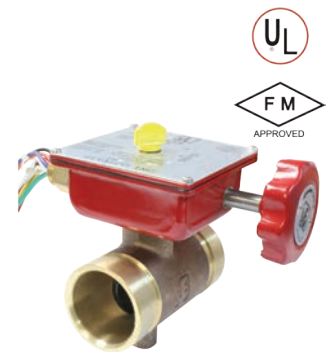

## Grooved Mon Ductile Iron Butterfly Valves Fig HPG

<b>Application:</b>	• Designed to initiate a signal at appropriate supervisory equipment to show whether a valve is open or closed, suitable for fire protection and distribution systems
<b>Design:</b>	• Gear-operated monitored butterfly valve
<b>End Connection:</b>	• Grooved
<b>Body Materials:</b>	• A1 bronze disc
<b>Seats &amp; Trim:</b>	• EPDM encapsulated
<b>Pressure:</b>	• Max <b>300 PSI</b> at 0°C to 120°C (32°F to 248°F)

Face to Face Dim	Part No.	Size NB (mm)
96.4	VGBFHP-76-GEAR	65
96.4	VGBFHP-88-GEAR	80
115.4	VGBFHP-114-GEAR	100
132.4	VGBFHP-165-GEAR	150
147.7	VGBFHP-200	200



## Safety Check Valves

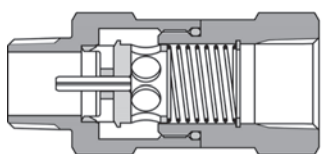
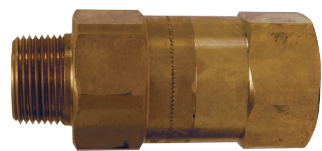

Open Position

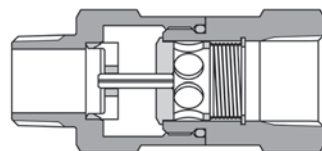

Closed Position

<b>Applications:</b>	<ul style="list-style-type: none"> <li>Used in temporary plant/factory air lines, construction sites, shipyards, or utilities</li> </ul>
<b>Features:</b>	<ul style="list-style-type: none"> <li>High-flow valve provides optimum performance</li> <li>Controls excess air flow (SCFM) in only one direction</li> <li>Automatically senses change in air flow and shuts off the flow in the event of a surge in excess of valve flow rating thus preventing hose whip</li> <li>Solid brass body and valve</li> <li>Stainless steel spring and roll pin</li> <li>Maximum operating pressure: <b>350 PSI</b></li> <li>Maximum temperature: <b>121°C (250°F)</b></li> <li>Does not prevent backflow</li> </ul>
<b>Specifications:</b>	<ul style="list-style-type: none"> <li>Conforms to OSHA regulation 1926.302 (b) (7) requiring a safety device at the source of the air supply and at branch air lines</li> </ul>
<b>How it Works:</b>	<ul style="list-style-type: none"> <li>Safety check valves utilise the pressure differential across the valve to operate the valve and spring assembly. The pressure differential is directly related to the flow of air (SCFM) through the valve</li> <li>When the pressure differential is within the operating limits - below the cut-off flow - of the unit, the force on the valve exerted by the spring is greater than that caused by the pressure differential (see "Open Position" graphic). The valve remains open and normal operation continues</li> <li>When the pressure differential is above the cut-off limit, the force on the valve exerted by the pressure differential is greater than the force exerted by the spring, and the valve closes (see the "Closed Position" graphic)</li> <li>After the repair is made, normal operation is automatically enabled when pressure across the valve equalizes through the bleeder hole</li> <li>The valve spring size can be specified by determining the air flow during normal operation and by estimating the air flow if a failure or rupture occurs</li> </ul>

NPT & Hose ID Size (inch)	Cut-off Flow Rate (SCFM at 90 PSI)	Brass NPT Part No.	Brass BSP Part No.	NPT & Hose ID Size (inch)	Cut-off Flow Rate (SCFM at 90 PSI)	Brass NPT Part No.	Brass BSP Part No.
¼	23-29	SCVL2	SCVL2BSP	1¼	260-290	SCVL10	SCVL10BSP
	30-36	SCVL3	SCVL3BSP		300-340	SCVM10	SCVM10BSP
¾	39-47	SCVM3	SCVM3BSP		440-500	SCVS10	SCVS10BSP
	52-65	SCVS3	SCVS3BSP		570-630	SCVH10	SCVH10BSP
½	70-78	SCVM4	SCVM4BSP	1½	300-360	SCVL12	SCVL12BSP
	80-96	SCVS4	SCVS4BSP		470-530	SCVM12	SCVM12BSP
¾	72-88	SCVL6	SCVL6BSP		564-602	SCVX12	SCVX12BSP
	92-108	SCVM6	SCVM6BSP		640-720	SCVS12	SCVS12BSP
	112-128	SCVR6	SCVR6BSP	750-830	SCVH12	SCVH12BSP	
	132-148	SCVJ6	SCVJ6BSP	2	510-590	SCVL16	SCVL16BSP
	160-180	SCVS6	SCVS6BSP		725-825	SCVM16	SCVM16BSP
	180-200	SCVH6	SCVH6BSP		900-1050	SCVS16	SCVS16BSP
1	165-195	SCVL8	SCVL8BSP		1100-1200	SCVH16	SCVH16BSP
	220-260	SCVM8	SCVM8BSP	3	1200-1400	SCVL24	SCVL24BSP
	280-320	SCVS8	SCVS8BSP		2400-2700	SCVS24	SCVS24BSP
	310-340	SCVH8	SCVH8BSP		2850-3050	SCVH24	SCVH24BSP



Not for use in applications where 100% of the available air is required, i.e. sand blast, pile driving rigs, expansion joint blow down pipes, etc.

## Horizontal Swing Check Valves



<b>Applications:</b>	<ul style="list-style-type: none"> <li>For use in plumbing and liquid piping systems to prevent back flow</li> </ul>
<b>Features:</b>	<ul style="list-style-type: none"> <li>Full flow performance with a minimum of turbulence or pressure loss</li> <li>Brass disc</li> <li>For horizontal or vertical use</li> <li>A positive seating disc allows flow only in one direction and a screw-in cap provides easy access for periodic cleaning</li> <li>Pressure rating: <b>200 PSI WOG</b></li> <li>Temperature range: <b>-29°C to 66°C (-20°F to 150°F)</b></li> </ul>

Female NPT (inch)	Brass Part No.
½	SWCV50
¾	SWCV75
1	SWCV100
1¼	SWCV125
1½	SWCV150
2	SWCV200
3	SWCV300
4	SWCV400



## Stainless Steel Swing Check Valves

<b>End Connection:</b>	• Screwed female BSP
<b>Body Material:</b>	• 316 stainless steel
<b>Pressure:</b>	• 200 PSI
<b>Temperature:</b>	• -20°C to 232°C (-4°F to 449°F) for water, oil and gas, and corrosive fluids

Size NB (mm)	Part No. <sup>1</sup>
15	SSC-015
20	SSC-020
25	SSC-025
32	SSC-032
40	SSC-040
50	SSC-050

<sup>1</sup> Also available in carbon steel.



## Forged Steel Check Valves

<b>Application:</b>	• Can be used for steam service
<b>Design:</b>	• Female NPT; bolted bonnet
<b>Body Materials:</b>	• Forged steel; Class 800; ASTM A105, ANSI B120.1
<b>Pressure Rating:</b>	• 1975 PSI
<b>Temperature:</b>	• Maximum temperature: 427°C (800°F)

Size		NPT Part #	BSP Part #
inch	mm		
½	15	FSCV50	FSCV50B
¾	20	FSCV75	FSCV75B
1	25	FSCV100	FSCV100B
1¼	32	FSCV125	FSCV125B
1½"	40	FSCV150	FSCV150B
2"	50	FSCV200	FSCV200B



## Cast Iron Flanged Ball Check Valves

<b>Application:</b>	• Water and sewerage and some slurry applications
<b>Design:</b>	• Flanged ball check valve
<b>End Connection:</b>	• Flanged Table D, rated to PN16
<b>Body Materials:</b>	• Cast iron, FBE coated • Aluminium ball with EPDM rubber liner
<b>Temperature:</b>	• -10° to 110°C (14°F to 230°F)
<b>Options:</b>	• Ductile iron body available on request

Face to Face Dim	Size (mm)	Part No.
200	50	BCK-050D
240	65	BCK-065D
260	80	BCK-080D
300	100	BCK-100D
300	100	BCK-100E
400	150	BCK-150D
500	200	BCK-200D
600	250	BCK-250D
700	300	BCK-300D



## Cast Iron Swing Flanged Check Valves Fig CVF-1161



<b>Application:</b>	• For water and neutral fluids
<b>Design:</b>	• Offers positive seating for resistance against back pressure or back flow
<b>End Connection:</b>	• Flanged Table D or E
<b>Body Materials:</b>	• Cast iron flanged, cast iron disc
<b>Seats &amp; Trim:</b>	• Metal seated
<b>Temperature:</b>	• 1,600 kPa @ -10°C to 120°C (14°F to 248°F)

Face to Face Dim	Size (mm)	Part No.
240	80	CVF-1161-080
292	100	CVF-1161-100E
356	150	CVF-1161-150E
495	200	CVF-1161-200E
622	250	CVF-1161-250E
699	300	CVF-1161-300E

## Stainless Steel Swing Flanged Check Valves



<b>Design:</b>	• To API 603 / ASME B1634
<b>End Connection:</b>	• Flanged to ANSI 150 LB is standard, table E available on request
<b>Body Material:</b>	• 316 stainless steel (CF8M)
<b>Pressure:</b>	• 285 PSI for water, oil and gas, and corrosive fluids
<b>Options:</b>	• ½" - 6" drilled table

Size NB (mm)	Part No.
65	VSC-150-065
80	VSC-150-080
100	VSC-150-100
150	VSC-150-150
200	VSC-150-200
250	VSC-150-250

Available on request  
 - 316 stainless steel drilled to table E ½" - 6"  
 - cast steel in 150# and 300# ANSI

## Cast Steel (WCB) Swing Check Valves Flanges ANSI 150



<b>Applications:</b>	• For use with air, water, oil, gas, and non-corrosive fluids, compatible with body and trim
<b>Design:</b>	• ASME B16 34 & BS 1868
<b>End Connection:</b>	• Flanged ANSI 150, face to face ASME B16.10; end connection: ASME B16.5
<b>Body Materials:</b>	• ASTM A216 WCB (cast steel)
<b>Disc:</b>	• ASTM A216 WCB+STL, seat ring -ASTM A216+13Cr
<b>Pressure:</b>	• 285 PSI CWP & -29°C to 425°C (-20°F to 797°F)
<b>Options:</b>	• Flanged ANSI 300lb. available on request

Size NB (mm)	Part No.
50	VSC-CS-150-050
65	VSC-CS-150-065
80	VSC-CS-150-080
100	VSC-CS-150-100
150	VSC-CS-150-150
200	VSC-CS-150-200
250	VSC-CS-150-250

## Bronze Globe Valves

<b>Application:</b>	• Steam, water, oil
<b>Design:</b>	• Class 150 globe valve; Grafoil® packing
<b>End Connection:</b>	• Screwed female BSP & NPT
<b>Body Material:</b>	• Bronze ASME B1.20.1; Malleable iron handwheel
<b>Seats &amp; Trim:</b>	• PTFE disc
<b>Pressure:</b>	• Pressure rating: <b>300 PSI</b> cold working pressure, <b>150 PSI</b> steam working pressure

Size		NPT	BSP
inch	mm	Part No.	Part No.
½	15	DGLBV50	DGLBV50B
¾	20	DGLBV75	DGLBV75B
1	25	DGLBV100	DGLBV100B
1¼	32	DGLBV125	DGLBV125B
1½	40	DGLBV150	DGLBV150B
2	50	DGLBV200	DGLBV200B



## Class 800 Forged Steel Globe Valves - BSP & NPT

<b>Application:</b>	• Petroleum, oil and gas, mining, and low-pressure steam. General services up to <b>425°C (797°F)</b>
<b>Design:</b>	• Class 800 forged steel BS5351, API 598, ASME B1.20.1
<b>End Connection:</b>	• Screwed Female: BSP, NPT & Socket Weld
<b>Body Material:</b>	• Forged steel - ASTM A 105N
<b>Seat &amp; Trim:</b>	• Seat- ASTM A105N + 13Cr, Stem- ASTM A182 F6a
<b>Pressure/Temp:</b>	• Maximum temperature: <b>427°C (800°F)</b> ; Pressure rating: <b>1975 PSI</b>
<b>Options:</b>	• Socket weld in forged steel, SS 316 available in screwed NPT
<b>Features:</b>	• OS&Y, bolted bonnet, plug disc
<b>Other:</b>	• Class 1500 available in NPT

Size		NPT	BSP
inch	mm	Part No.	Part No.
½	15	FSGLBV50	FSGLBV50B
¾	20	FSGLBV75	FSGLBV75B
1	25	FSGLBV100	FSGLBV100B
1¼	32	FSGLBV125	FSGLBV125B
1½	40	FSGLBV150	FSGLBV150B
2	50	FSGLBV200	FSGLBV200B



## Single Check Valves Approved & Tested - Flanged & Grooved



Australian Standard



Flanged



Grooved

<b>Application:</b>	• Fire sprinkler systems and potable water to prevent back siphonage
<b>Design:</b>	• Single testable detector check valve approved
<b>End Connection:</b>	• Flanged - ANSI B16.1 Class 125 & drilled to AS2129 table D & E • Grooved - to AWWA C606
<b>Materials:</b>	• Body - ductile Iron • Stem - stainless steel • EPDM elastomers and FBE coated
<b>Approvals:</b>	• AS 4020, AS standards mark certified, watermarked, and UL/FM approved
<b>Working Pressure:</b>	• 175 PSI
<b>Temperature:</b>	• 60°C (140°F)

Face to Face Dim	Size (mm)	Part No.	TE Fire Line SCV
420	100	SCV-100	Flanged TE
420	100	SCV-100G	Grooved
570	150	SCV-150	Flanged TE
570	150	SCV-150G	Grooved

## Single Detector Check Valves with 20mm Spacer Bypass



<b>Application:</b>	• Backflow prevention
<b>Style:</b>	• Single detector check valve • Spacer bypass
<b>Options:</b>	• Also available in flanged ends Table E

Face to Face Dim	Size (mm)	Part No.
420	100 x 25	SCV-100X25CW
570	150 x 25	SCV-150X25CW

G

## Yarra Valley Single Fireline Detector Check Valves with Metered Bypass



<b>Application:</b>	• Backflow prevention
<b>Style:</b>	• Single fireline detector check valve metered bypass
<b>End Connection:</b>	• Flanged Table E

Face to Face Dim	Size (mm)	Part No.
420	100 x 25	SCV-100X25YV
570	150 x 25	SCV-150X25YV

## Mini Needle Valves

<b>Design:</b>	• Available in a variety of materials and handle options
<b>End Connection:</b>	• 1/8" and 1/4" are orifice size 0.172", flow coefficient: 0.42 • 1/2" orifice size is 0.187", flow coefficient: 0.44, hex body
<b>Body Material:</b>	• Stems are 316 stainless steel
<b>Seat &amp; Trim:</b>	• Metal-to-metal hard seat design is 100% helium leak tested to 1 x 10-4 ml/s at <b>200 PSI</b>
<b>Features:</b>	• Stem threads are rolled for strength and ease of operation • FKM O-ring seal and PTFE back-up ring below the threads protects from corrosion and galling

### Female to Male

Size		Handle Style	PSI @ 200°C (392°F)	Material	NPT	BSP
inch	mm				Part No.	Part No.
1/8	3.17	knurled knob	6000	brass	MFB101	MFB101B
		T design	10000	zinc nickel-plated steel	MFC101	MFC101B
		T design	10000	316 stainless steel	MFS101	MFS101B
1/4	6.35	knurled knob	6000	brass	MFB102	MFB102B
		T design	10000	zinc nickel-plated steel	MFC102	MFC102B
		T design	10000	316 stainless steel	MFS102	MFS102B
1/2	12.7	T design	10000	zinc nickel-plated steel	MFC404	MFC404B
		T design	10000	316 stainless steel	MFS404	MFS404B

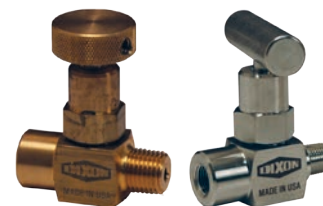

Female to Male

### Female to Female

Size		Handle Style	PSI @ 200°C (392°F)	Material	NPT	BSP
inch	mm				Part No.	Part No.
1/8	3.17	knurled knob	6000	brass	FFB101	FFB101B
		T design	10000	zinc nickel-plated steel	FFC101	FFC101B
		T design	10000	316 stainless steel	FFS101	FFS101B
1/4	6.35	knurled knob	6000	brass	FFB102	FFB102B
		T design	10000	zinc nickel-plated steel	FFC102	FFC102B
		T design	10000	316 stainless steel	FFS102	FFS102B
1/2	12.7	T design	10000	zinc nickel-plated steel	FFC404	FFC404B
		T design	10000	316 stainless steel	FFS404	FFS404B



Female to Female

## Multiport Needle Valves

<b>Application:</b>	• Reduces the number of gauge and other instrument connections to permanent piping installations, decreasing possible leak paths
<b>Design:</b>	• Available in a variety of materials and handle options
<b>End Connection:</b>	• 1/2" female NPT port • Orifice size is 0.187", flow coefficient: 0.44
<b>Body Material:</b>	• Stems are 316 stainless steel
<b>Seat &amp; Trim:</b>	• Metal-to-metal hard seat design is 100% helium leak tested to 1 x 10-4 ml/s at <b>200 PSI</b>
<b>Features:</b>	• Stems are 316 stainless steel • Threads are rolled for strength and ease of operation • FKM O-ring seal and PTFE back-up ring below the threads protects from corrosion and galling

### Hard Seat Female to Male

Size		Handle Style	PSI @ 200°C (392°F)	Material	NPT	BSP
inch	mm				Part No.	Part No.
1/2	12.7	T design	10000	Zinc Nickel plated Steel	MFC204	MFC204B
		T design	10000	316 Stainless Steel	MFS204	MFS204B
3/4	19.05	T design	10000	Zinc Nickel plated Steel	MFC20604	MFC20604B
		T design	10000	316 Stainless Steel	MFS20604	MFS20604B



Hard Seat Female to Male

### Soft Seat Female to Male

Size		Handle Style	PSI @ 200°C (392°F)	Material	NPT	BSP
inch	mm				Part No.	Part No.
1/2	12.7	T design	6000	Zinc Nickel plated Steel	MFC304	MFC304B
		T design	6000	316 Stainless Steel	MFS304	MFS304B
3/4	19.05	T design	6000	Zinc Nickel plated Steel	MFC30604	MFC30604B
		T design	6000	316 Stainless Steel	MFS30604	MFS30604B



Soft Seat Female to Male



## Block and Bleed Needle Valves

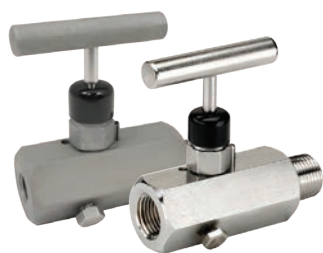

Hard Seat Female to Male



Soft Seat Female to Male

<b>Design:</b>	<ul style="list-style-type: none"> <li>Allows pressure to be bled off without disturbing the permanent piping installation, allowing quick and easy removal or replacement of instruments</li> </ul>
<b>End Connection:</b>	<ul style="list-style-type: none"> <li>Orifice size is 0.187", flow coefficient: 0.44, hex body</li> </ul>
<b>Body Material:</b>	<ul style="list-style-type: none"> <li>Stems are 316 stainless steel</li> </ul>
<b>Seat &amp; Trim:</b>	<ul style="list-style-type: none"> <li>Metal-to-metal hard seat design is 100% helium leak tested to 1 x 10<sup>-4</sup> ml/s at <b>200 PSI</b></li> </ul>
<b>Features:</b>	<ul style="list-style-type: none"> <li>Stem threads are rolled for strength and ease of operation</li> <li>FKM O-ring seal and PTFE back-up ring below the threads protects from corrosion and galling</li> <li>0.090" bleed hole located on bottom is controlled by a 1/4"-20 UNF-2A bleed screw</li> </ul>

### Hard Seat Female to Male

Size		Handle Style	PSI @ 200°C (392°F)	Material	NPT	BSP
inch	mm				Part No.	Part No.
1/4	6.35	T design	10000	zinc nickel plated steel	MFC602	MFC602B
		T design	10000	316 stainless steel	MFS602	MFS602B
1/2	12.7	T design	10000	zinc nickel plated steel	MFC604	MFC604B
		T design	10000	316 stainless steel	MFS604	MFS604B

### Soft Seat Female to Male

Size		Handle Style	PSI @ 200°C (392°F)	Material	NPT	BSP
inch	mm				Part No.	Part No.
1/4	6.35	T design	10000	zinc nickel plated steel	MFC702	MFC702B
		T design	10000	316 stainless steel	MFS702	MFS702B
1/2	12.7	T design	10000	zinc nickel plated steel	MFC704	MFC704B
		T design	10000	316 stainless steel	MFS704	MFS704B

## Bleed Needle Valves



Hard Seat Male



Soft Tip Male

<b>Design:</b>	<ul style="list-style-type: none"> <li>Convenient way to relieve process pressures trapped between a shut-off valve and the instrument</li> </ul>
<b>End Connection:</b>	<ul style="list-style-type: none"> <li>Bleed port: 0.159"</li> </ul>
<b>Body Material:</b>	<ul style="list-style-type: none"> <li>Stems are 316 stainless steel</li> </ul>
<b>Seat &amp; Trim:</b>	<ul style="list-style-type: none"> <li>Metal-to-metal hard seat design is 100% helium leak tested to 1 x 10<sup>-4</sup> ml/s at <b>200 PSI</b></li> </ul>
<b>Features:</b>	<ul style="list-style-type: none"> <li>Stem threads are rolled for strength and ease of operation</li> <li>FKM O-ring seal and PTFE back-up ring below the threads protects from corrosion and galling</li> <li>0.090" bleed hole located on bottom is controlled by a 1/4"-20 UNF-2A bleed screw</li> <li>Non-rotating soft tip stem and a backup metal-to-metal seal</li> </ul>

### Hard Seat Male

Size		Handle Style	PSI @ 200°C (392°F)	Material	NPT	BSP
inch	mm				Part No.	Part No.
1/4	6.35	T design	10000	zinc nickel plated steel	MC802	MC802B
		T design	10000	316 stainless steel	MS802	MS802B
1/2	12.7	T design	10000	zinc nickel plated steel	MC804	MC804B
		T design	10000	316 stainless steel	MS804	MS804B

### Soft Tip Male

Size		Handle Style	PSI @ 200°C (392°F)	Material	NPT	BSP
inch	mm				Part No.	Part No.
1/4	6.35	T design	6000	zinc nickel plated steel	MC852	MC852B
		T design	6000	316 stainless steel	MS852	MS852B
1/2	12.7	T design	6000	zinc nickel plated steel	MC854	MC854B
		T design	6000	316 stainless steel	MS854	MS854B

## Relief Valves with Side Outlet - Fig PREL

<b>Application:</b>	• Suitable for discharge of steam, water, oil, air, and liquids non-injurious to copper alloys
<b>Design:</b>	• This relief valve has a closed side outlet with right angle discharge; the outlet is female threaded and of the same size as the inlet
<b>End Connection:</b>	• BSP Male
<b>Body Material:</b>	• Bronze
<b>Seats &amp; Trim:</b>	• Bronze, SS304
<b>Temperature:</b>	• <b>-45°C to 185°C (-49°F to 365°F)</b>
<b>Pressure:</b>	• Factory set to 1000Kpa and can be field adjusted from 300 to 1000Kpa

Size (mm)	Part No.	Standard Setting
15	VR-268-15	<b>145 PSI</b> (1000 kPa)
20	VR-268-20	<b>145 PSI</b> (1000 kPa)
25	VR-268-25	<b>145 PSI</b> (1000 kPa)
32	VR-268-32	<b>145 PSI</b> (1000 kPa)
40	VR-268-40	<b>145 PSI</b> (1000 kPa)
50	VR-268-50	<b>145 PSI</b> (1000 kPa)

For settings other than standard, contact Dixon™.

## Stainless Steel Relief Valves

<b>Application:</b>	• Water, oil, gas, steam, and corrosive fluids
<b>Design:</b>	• Right angle relief valve, field adjustable
<b>End Connection:</b>	• Threaded female BSP
<b>Material:</b>	• 316 stainless steel body and seat
<b>Seat:</b>	• PTFE soft seat
<b>Pressure:</b>	• Factory set to 1000Kpa. Field adjustable from 300 to 1000kPa
<b>Temperature:</b>	• <b>-20°C to 290°C (-4°F to 554°F)</b>

Size (mm)	Part No.
15	SRV-015
20	SRV-020
25	SRV-025
32	SRV-032
40	SRV-040
50	SRV-050



G

## Round Hole Strainers



zinc plated steel



304 stainless steel

**Applications:**

- For use on the submersed end of suction hose to prevent debris from entering the pump during operation

NPSM Size (inch)	Zinc Plated Steel Part #	304 Stainless Steel Part #
¾	RHS5	---
1	RHS10	---
1½	RHS20	RRHS20
2	RHS25	RRHS25
2½	RHS30	---
3	RHS35	RRHS35
4	RHS40	RRHS40
6	RHS60	RRHS60
8	RHS80	---
10	RHS100	---
12	RHS120	---

## Square Hole Strainers

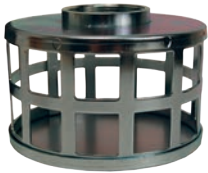

NPSM Size (inch)	Zinc Plated Steel Part #
2"	SHS25
3"	SHS35
4"	SHS40
6"	SHS60
8"	SHS80
10"	SHS100
12"	SHS120

## Polypropylene Strainers



NPT Size (inch)	Black Polypropylene with 30% Fiberglass Part #
1½"	TSS20
2"	TSS25
3"	TSS35
4"	TSS40

## Round Hole Long Strainers



NPT Size (inch)	Zinc Plated Steel Part #
1½"	RSS20
2"	RSS25
3"	RSS35
4"	RSS40



## Y Line Strainers

### Cast Iron

<b>Design:</b>	• 20 x 20 mesh
<b>Pressure:</b>	• Working pressure: <b>400 PSI WOG, 250 PSI steam</b>
<b>Features:</b>	• Graphite gasket; plug ported for blowdown service
<b>Specification:</b>	• No replacement screens available

Female NPT Size (inch)	Cast Iron Part #
¼	Y001
¾	Y002
½	Y003
¾	Y004
1	Y005
1¼	Y006
1½	Y007
2	Y008

Also available in BSP thread.



### Cast Bronze

<b>Design:</b>	• ¼" - ½" uses 50 x 50 mesh; ¾" - 2" uses 20 x 20 mesh
<b>Pressure:</b>	• Working pressure: <b>400 PSI WOG, 125 PSI steam</b>

Female NPT Size (inch)	Cast Bronze Part #	304 Stainless Steel Replacement Screens Part #
¼	59-001	G3271-00
¾	59-002	G2457-00
½	59-003	G2457-00
¾	59-004	G3224-00
1	59-005	G3225-00
1¼	59-006	G3231-00
1½	59-007	G3229-00
2	59-008	G3230-00

Also available in BSP thread.



replacement screen

### Polypropylene

<b>Design:</b>	• Protects and prevents clogging of pipelines, pumps, and spray tips: ¾" and 1" use 40 mesh, 1½" and 2" use 40/20 mesh
<b>Pressure:</b>	• Maximum operating pressure: <b>90 PSI at 21°C (70°F)</b>
<b>Feature:</b>	• Easy access for cleaning
<b>Body:</b>	• Glass-filled polypropylene

Female NPT Size (inch)	Polypropylene Part #	304 Stainless Steel Replacement Screens Part #
¾	PYLS7540	64178
1	PYLS10040	61746
1½	PYLS15040	61509
2	PYLS20040	61509

Also available in BSP thread.



replacement screen

## Polypropylene T Line Strainers

<b>Design:</b>	• ¾" uses 50 mesh, 1" uses 40 mesh
<b>Pressure:</b>	• Maximum operating pressure: <b>100 PSI at 21°C (70°F)</b>
<b>Feature:</b>	• White polypropylene allows easy inspection

Female NPT Size (inch)	Polypropylene Part #	304 Stainless Steel Replacement Screens Part #
¾	PTLS7540	61405
1	PTLS10040	61405





## H

BISO Strainers .....	297
SISO Strainers .....	298
<b>Fittings</b>	
Inlet Scoop .....	299
Inlet Rose .....	299
Thru Hull Skin Fittings .....	300
Baskets .....	300-301
<b>Accessories</b>	
Mounting Bracket .....	301
Adjustable Arms .....	301
Replacement Parts .....	301-302
Gaskets .....	302



## BISO Strainers - Bottom Inlet, Side Outlet

<b>Application:</b>	<ul style="list-style-type: none"> <li>Suitable for applications where a superior corrosion-resistant stainless steel is required to filter liquids. Commonly used to strain seawater for engines, generators, HVAC systems in vessels. However, it can be used for other liquids that require a high-grade stainless steel filter to protect pumps, nozzles, and injectors from large particles.</li> </ul>
<b>Body Material:</b>	<ul style="list-style-type: none"> <li>Electro-polished AISI 2205 cast stainless steel</li> </ul>
<b>Lid Material:</b>	<ul style="list-style-type: none"> <li>Electro-polished AISI 2205 cast stainless steel</li> </ul>
<b>Features:</b>	<ul style="list-style-type: none"> <li>Offset outlet for improved performance</li> <li>Secured by five wing nuts for safe, quick, and easy access</li> <li>No tools required</li> <li>Swing-down eye bolts eliminates need to remove nuts</li> <li>BSP thread inlet and outlet; flanges available on request</li> <li>Full height, high-impact-resistant ABS basket</li> <li>Cast anode connection point to combat galvanic corrosion</li> </ul>
<b>Options:</b>	<ul style="list-style-type: none"> <li>316 stainless steel basket</li> <li>Clear polycarbonate or solid lid</li> </ul>

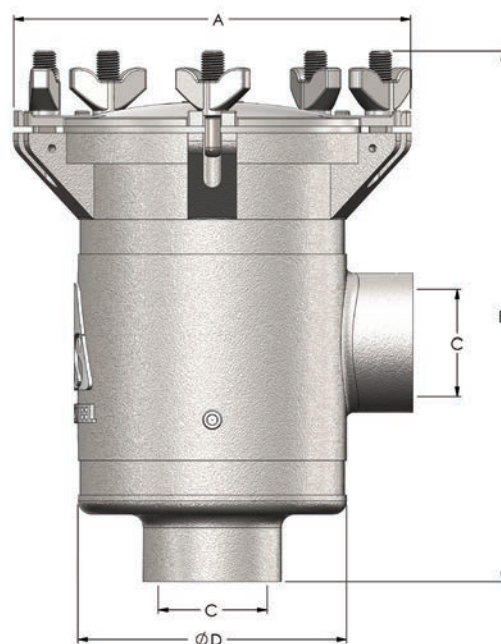

Size BSP (inch)	Part No.	Lid	Flow Rate 1 Bar L/Min	Lid Width A (mm)	Height B (mm)	Thread Size C BSP (inch)	Thread Type	Body Width D (mm)	Weight (kg)
1	WS-BISO-100-C-A	clear	425	150	235	1	male x female	95	2.90
	WS-BISO-100-S-A	solid	425	150	235	1	male x female	95	3.10
1½	WS-BISO-150-C-A	clear	903	150	235	1½	male x female	95	3.05
	WS-BISO-150-S-A	solid	903	150	235	1½	male x female	95	3.15
2	WS-BISO-200-C-A	clear	1,375	200	272	2	male x female	140	5.70
	WS-BISO-200-S-A	solid	1,375	200	272	2	male x female	140	6.20
2½	WS-BISO-250-C-A	clear	1,974	200	272	2½	female x female	140	5.90
	WS-BISO-250-S-A	solid	1,974	200	272	2½	female x female	140	6.25
3	WS-BISO-300-C-A	clear	3,103	235	332	3	female x female	164	11.55
	WS-BISO-300-S-A	solid	3,103	235	332	3	female x female	164	12.30
4	WS-BISO-400-C-A	clear	5,710	273	474	4	female x female	220	18.15
	WS-BISO-400-S-A	solid	5,710	273	474	4	female x female	220	18.95
6	WS-BISO-600-S-A	solid	13,538	360	510	6	female x female	310	32.00



**SISO Strainers - Side Inlet, Side Outlet**

<b>Application:</b>	<ul style="list-style-type: none"> <li>Suitable for applications where a superior corrosion-resistant stainless steel is required to filter liquids. Commonly used to strain seawater for engines, generators, HVAC systems in vessels. However, it can be used for other liquids that require a high-grade stainless steel filter to protect pumps, nozzles, and injectors from large particles.</li> </ul>
<b>Body Material:</b>	<ul style="list-style-type: none"> <li>Electro-polished AISI 2205 cast stainless steel</li> </ul>
<b>Lid Material:</b>	<ul style="list-style-type: none"> <li>Electro-polished AISI 2205 cast stainless steel</li> </ul>
<b>Features:</b>	<ul style="list-style-type: none"> <li>Offset inlet and outlet for improved performance</li> <li>Free standing, base mounted</li> <li>Secured by five wing nuts for safe, quick, and easy access</li> <li>No tools required</li> <li>Swing-down eye bolts eliminates need to remove nuts</li> <li>BSP thread inlet and outlet, flanges available on request</li> <li>Full height high-impact-resistant ABS basket</li> <li>Cast anode connection point to combat galvanic corrosion</li> <li>Drain plug</li> <li>Lower outlet position allows for applications that require a header tank or mounting above the waterline</li> </ul>
<b>Options:</b>	<ul style="list-style-type: none"> <li>316 stainless steel basket</li> <li>Clear polycarbonate or solid lid</li> </ul>



Size BSP (inch)	Part No.	Lid	Flow Rate 1 Bar L/Min	Lid Width A (mm)	Height B (mm)	Thread Size C BSP (inch)	Thread Type	Body Width D (mm)	Weight (kg)
1	WS-SISO-100-C-A	clear	332	150	235	1	female x female	95	3.60
	WS-SISO-100-S-A	solid	332	150	235	1	female x female	95	3.75
1¼	WS-SISO-125-C-A	clear	535	200	269	1¼	female x female	133	6.39
	WS-SISO-125-S-A	solid	535	200	269	1¼	female x female	133	6.85
1½	WS-SISO-150-C-A	clear	171	200	269	1½	female x female	133	6.45
	WS-SISO-150-S-A	solid	171	200	269	1½	female x female	133	6.75
2	WS-SISO-200-C-A	clear	1,349	200	269	2	female x female	133	6.40
	WS-SISO-200-S-A	solid	1,349	200	269	2	female x female	133	6.90
2½	WS-SISO-250-C-A	clear	1,882	235	365	2½	female x female	164	13.35
	WS-SISO-250-S-A	solid	1,882	235	365	2½	female x female	164	13.95
3	WS-SISO-300-C-A	clear	2,761	235	365	3	female x female	164	14.30
	WS-SISO-300-S-A	solid	2,761	235	365	3	female x female	164	15.15
4	WS-SISO-400-C-A	clear	5,366	273	478	4	female x female	221	22.95
	WS-SISO-400-S-A	solid	5,366	273	478	4	female x female	221	23.75

**ARCTIC STEEL**

+44 (0)1772 323529  
europe.dixonvalve.com  
sale@technobearing.ru

TECHNOBEARING.RU

**DGEL2020**  
8 (800) 700-72-07

## Inlet Scoop Strainers

<b>Application:</b>	<ul style="list-style-type: none"> <li>Designed to scoop water into thru hull fittings when the boat is in motion, at the same time preventing large particles and debris from entering the marine systems aboard.</li> </ul>
<b>Material:</b>	<ul style="list-style-type: none"> <li>Solid cast 2205 stainless steel</li> </ul>

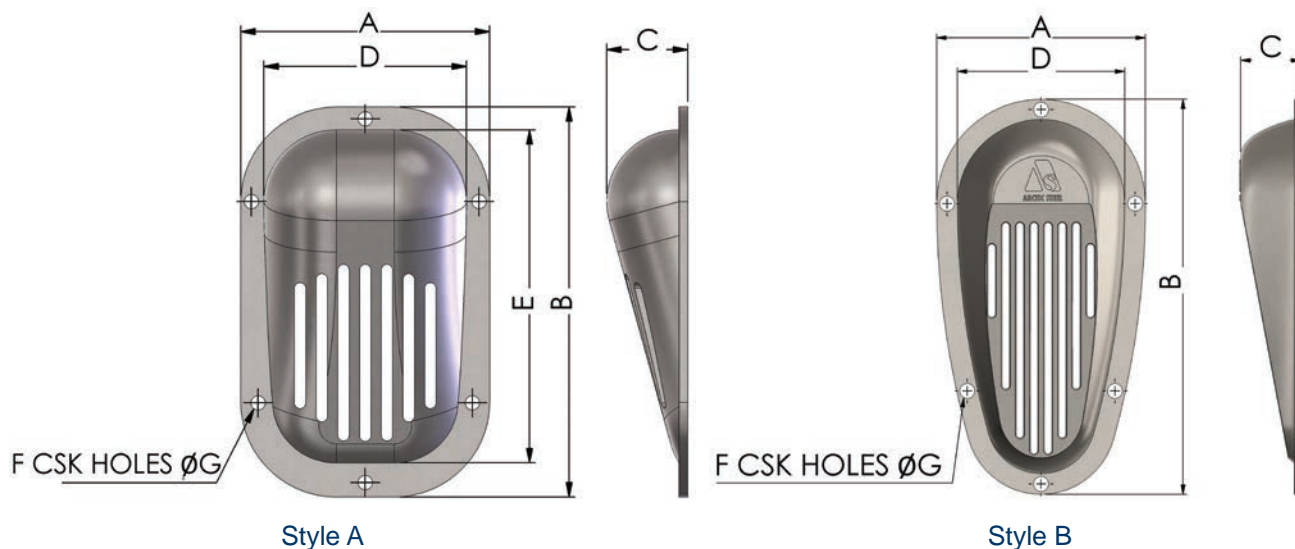

Size (mm)	Part No.	A (mm)	B (mm)	C (mm)	D (mm)	E (mm)	F (mm)	G (mm)	Style	Fits Thru Hulls (inch)	Weight (kg)
140 x 100	ISS140-100	100	140	28	70	115	6	5	A	½, ¾, 1	0.40
210 x 115	ISS210-115	115	210	32	82	180	6	5	B	1¼, 1½	0.65
315 x 160	ISS315-160	160	315	50	127	280	8	5	B	2, 2½, 3	1.8
410 x 206	ISS410-206	206	410	60	170	370	10	5	B	4	3.9
510 x 280	ISS510-280	275	507	70	230	470	12	6	B	6	4.7

## Inlet Rose Strainers



Size (mm)	Part No.	A (mm)	B (mm)	C (mm)	D (mm)	E (mm)	Fits Thru Hulls (inch)	Weight (kg)
90	IRS-90	90	66	23	4	5	½, ¾, 1	0.10
150	IRS-150	153	118	35	6	5	1¼, 1½, 2, 2½, 3	0.65



## Thru Hull Skin Fittings

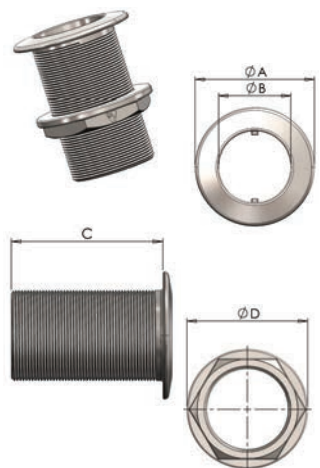
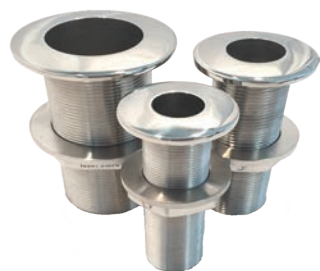

**Material:** • Solid cast 2205 stainless steel

Thread BSP (inch)	Part No.	A (mm)	B (mm)	C (mm)	D (mm)	Fits Inlet Scoops	Weight (kg)
½	TH/SF-050A	38	12	55	38	ISS140-100, IRS-90	0.20
¾	TH/SF-075A	45	18.5	65	45	ISS140-100, IRS-90	0.25
1	TH/SF-100A	51.5	24	86	51.5	ISS140-100, IRS-90	0.40
1¼	TH/SF-125A	61.5	30.9	85	63.5	ISS210-115, IRS-150	0.50
1½	TH/SF-150A	70	40	85	70	ISS210-115, IRS-150	0.55
2	TH/SF-200A	84	50.8	100	84	ISS315-160, IRS-150	0.80
2½	TH/SF-250A	98	62.5	100	98	ISS315-160, IRS-150	1.30
3	TH/SF-300A	116	78	124	116	ISS315-160, IRS-150	1.65
4	TH/SF-400A	145	94	150	145	ISS410-206	3.60
long reach ¾	TH/SF-LR-075A	45	18.5	110	45	ISS140-100	0.35
long reach 1	TH/SF-LR-100A	51.5	24	110	51.5	ISS140-100	0.45
long reach 1½	TH/SF-LR-150A	70	40	114.5	70	ISS210-115	0.60

## Water Strainer Accessories ABS Plastic Baskets



Size (inch)	Style	Part No.	Weight (kg)
1, 1½	BISO	WS-BISO-150-005	0.05
2, 2½	BISO	WS-BISO-250-005	0.20
3	BISO	WS-BISO-300-005	0.25
4	BISO	WS-BISO-400-005	0.45
6	BISO	WS-BISO-600-005	0.75
1	SISO	WS-SISO-100-005	0.05
1¼, 1½, 2	SISO	WS-SISO-200-005	0.15
2½, 3	SISO	WS-SISO-300-005	0.40
4	SISO	WS-SISO-400-005	0.60



**ARCTIC STEEL**

### 316 Stainless Steel Baskets

Size (inch)	Style	Part No.	Weight (kg)
1, 1½	BISO	WS-BISO150-011-2	0.10
2, 2½	BISO	WS-BISO250-011-2	0.45
3	BISO	WS-BISO300-011-2	0.35
4	BISO	WS-BISO400-011-2	0.55
6	BISO	WS-BISO600-011-2	1.26
1¼, 1½, 2	SISO	WS-SISO200-011-2	0.35
3	SISO	WS-SISO300-011-2	0.85
4	SISO	WS-SISO400-011-2	1.30



BISO

SISO

### Strainer Mounting Bracket

BISO Strainer Size (inch)	Style	Part No.	Weight (kg)
1, 1½	BISO	WS-BR-150	0.40
2, 2½	BISO	WS-BR-250	0.55
3	BISO	WS-BR-300	0.60
4	BISO	WS-BR-400	0.90



### Adjustable Arms

Size (mm)	Part No.	Weight (kg)
100mm	WS-ADJ-BR-ARM100	0.60
150mm	WS-ADJ-BR-ARM150	0.65
200mm	WS-ADJ-BR-ARM200	0.65



### Strainer 316 Wing Nuts

Size (mm)	Description	Part No.	Weight (kg)
10mm	Suits all strainers	WS-WNSS-M10	0.20



### Replacement Solid Lid

Size (inch)	Style	Part No.	Weight (kg)
1, 1½	BISO	WS-150-002	0.45
1	SISO		
2, 2½	BISO	WS-250-002	1.10
1¼, 1½, 2	SISO		
3	BISO	WS-300-002	1.95
2½, 3	SISO		
4	BISO	WS-400-002	2.50
	SISO		
6	BISO	WS-600-002	4.50



## Replacement Clear Lid Kit and Separate Parts



Size (inch)	Style	Description	Part No.	Weight (kg)
1, 1½	BISO	clear lid kit (cast ring and poly disc)	WS-150-010	0.30
1	SISO			
1, 1½	BISO	cast retaining ring only	WS-150-003	0.25
1	SISO			
1, 1½	BISO	polycarbonate disc only	WS-150-004	0.50
1	SISO			
2, 2½	BISO	clear lid kit (cast ring and poly disc)	WS-250-010	0.70
1¼, 1½, 2	SISO			
2, 2½	BISO	cast retaining ring only	WS-250-003	0.50
1¼, 1½, 2	SISO			
2, 2½	BISO	polycarbonate disc only	WS-250-004	0.15
1¼, 1½, 2	SISO			
3	BISO	clear lid kit (cast ring and poly disc)	WS-300-010	1.00
2½, 3	SISO			
3	BISO	cast retaining ring only	WS-300-003	0.70
2½, 3	SISO			
3	BISO	polycarbonate disc only	WS-300-004	0.30
2½, 3	SISO			
4	BISO	clear lid kit (cast ring and poly disc)	WS-400-010	1.87
	SISO			
	BISO	cast retaining ring only	WS-400-003	1.45
	SISO			
BISO	polycarbonate disc only	WS-400-004	0.42	
SISO				

## Strainer Gaskets

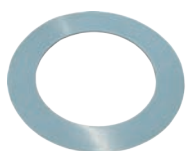

Size (inch)	Style	Part No.	Weight (kg)
1, 1½	BISO	WS-150-006	0.02
1	SISO		
2, 2½	BISO	WS-250-006	0.05
1¼, 1½, 2	SISO		
3	BISO	WS-300-006	0.05
2½, 3	SISO		
4	BISO	WS-400-006	0.10
	SISO		
6	BISO	WS-600-006	0.13

## Valves



### Options:

- A full range of valves suitable for use within the marine applications are available

## Hose

### Options:

- A wide range of hoses are available for marine including wet exhaust, fuel, sanitation, and a wide variety of PVC



ARCTIC STEEL



+44 (0)1772 323529  
europe.dixonvalve.com  
sale@technobearing.ru



# Hose Range & Hose Assemblies Index



Hose Range & Hose Assemblies .....	304
Metallic Hoses.....	304
PTFE Hoses .....	304
Rubber Hoses .....	305
Composite Hoses .....	305
Spiral PVC Hoses .....	305
Hand-Built Hoses .....	305
Specialist & Bespoke Hoses .....	306



# Hose Range & Hose Assemblies

## Hose Range and Hose Assemblies



Dixon Group Europe is a specialist supplier of industrial hose and hose assemblies; we are certified to the Pressure Equipment Directive 2014/68/EU to manufacture flexible hose assemblies positioning us as a market leader in this field.

At Dixon™ we are driven to provide 'the right connection' in meeting specific hose requirements across all industries. Our strength in service, support, and advice ensure the correct specification of bespoke hose assemblies and couplings.

With manufacturing and engineering facilities approved to BSI ISO 9001 and with over 100 years' experience, Dixon™ can design and produce fully tested and certified customised hose solutions to meet and resolve our customers' fluid and air handling challenges.

For further information on any of the hoses below please do not hesitate to contact our sales office or visit us online at [dixoneurope.co.uk](http://dixoneurope.co.uk).



### Metallic Hoses

Versatile robust hose suited to high-pressure, high-temperature, and corrosive applications, flexible metal hoses can accommodate angular movements, temperature expansion, vibration, and misalignment.

Dixon™ offers a variety of metallic hose options suited to individual applications including steam, compressed air, petrochemical, and vacuum.

All corrugated flexible metal hose assemblies meet the requirements of class 1 of the EN ISO 10380 standard and the Pressure Equipment Directive 2014/68/EU.

Options include a variety of braids and a range of standard and close pitch constructions. Assemblies can be Radiograph, NDT, or Dyepen tested.

Metallic hose assemblies are available in a wide variety of end configurations in common materials including stainless steel, aluminium, and mild steel.

### PTFE Hoses

Inert to practically all commercial chemicals, acids, solvents, and hydraulic fluids, these assemblies absorb no moisture and have low volumetric expansion. They are easy to clean and are particularly suited to arduous flexing over an extended temperature range. PTFE is useful in the pharmaceutical and food processing industries, as it is tasteless and odourless and does not contaminate the media being passed through the hose.

Available options include smoothbore, convoluted, and antistatic PTFE complete with either a stainless steel or polymer braid. Bounce ring protectors, spiral guards, and anti-static liners are also available.

PTFE hose assemblies are available in a wide variety of end configurations in common materials including stainless steel, aluminium, and mild steel.



# Hose Range & Hose Assemblies

## Rubber Hoses

We carry a complete range of extruded and mandrel-wrapped rubber hoses for a variety of applications, environments, and media including:

- Air
- Water
- Multi-Purpose
- Chemical
- Steam
- Oil, LPG
- Food & Beverage

Certified to relevant standards.



## Composite Hoses

Flexible, weatherproof, and abrasive-resistant composite hoses handle a variety of media whether on road or rail tankers, from ship to shore, or for general duty in plants. Assemblies are electrically resistant to <10 ohms to BS5842:1980 clause 6.2 (EN ISO 8031).

- Oil
- Chemical
- PTFE-lined chemical
- Cryogenic LNG
- Cryogenic LPG



## Spiral PVC Hoses

The range of high-quality spirally reinforced PVC hoses are suited to transferring a variety of media including water, slurries, abrasive media, oils, and food within industries serving the non-food or food sectors.

Certified to relevant standards.



## Hand-Built Hoses

This special range of Dixon™ rubber hoses are often referred to as hand-built hoses. Assemblies with either built-in or crimped ends. Built to bespoke customers' requirements, according to application.



# Hose Range & Hose Assemblies



## ***Specialist and Bespoke Hoses***

Hoses can be designed and engineered to bespoke requirements including heat shrink and jacketed covers. Heated/jacketed hoses can also be provided using hot water or steam.

Metallic and industrial hoses can be provided with an electric heat trace cabling to facilitate heating of the hose body ensuring continuous flow of product. This can be supplied and terminated with an electrical junction box at one hose end.

GSM ball joint armoured hoses available in galvanised steel and stainless steel are suitable for low- and high-pressure conditions including high-pressure hydraulic use in a variety of harsh applications and environments.

Hose Assemblies Technical .....	308-325
Be SAFE .....	308
STAMPED .....	309
Hose & Coupling Safety .....	310-319
Dixon™ Pressure Recommendation Chart	320-325
Hose Technical .....	326-337
Properties of Rubber .....	326
Hose Bend Radius Recommendations .....	326
Basic Compounds in Rubber Hose .....	327
Water Discharge Table .....	327
Pressure Drop Charts & Flow Rates .....	328-329
Layflat Pressure Drop & Temperature .....	329
Rubber Chemical Resistance Charts .....	330-335
PVC Chemical Resistance Charts .....	336-338
Forces at Work & Force Chart .....	339-340
Corrosion Resistance .....	341-347
Pipe & Pipe Fittings Technical .....	348-354
Identifying Threads .....	348
Thread Information .....	349
Thread Sealing Tips .....	350
Nominal Dimensions .....	351
Flange Specifications .....	352-353
Pipe Threads - NPT vs. BSP .....	354
Hose Fittings & Couplings Technical .....	355-364
Cam & Groove Specifications .....	355
Claw Coupling Specifications .....	356
Boss™ Fittings & Clamp Specifications	357-358
Crimped Specifications .....	359-360
Dixon™ Hydraulic & Pneumatic Profiles	361-363
Fluid Compatibility .....	364
Crimp Recommendation Guide .....	365-370
Valves Technical Information .....	371
Technical References .....	372-377
Steam Temp. - Pressure Conversion Guide	372
Vacuum Conversions .....	373
Ft. of Water to In. of Mercury Conversions	373
Pressure Conversions .....	373
Measurement Information .....	373
Imperial to Decimal Conversions .....	374
Temperature Conversions .....	375
Formulae .....	376
MSHA & OSHA Regulations .....	377
Hose & Coupling Site Safety Survey .....	378
Glossary Of Terms .....	379-380



**SAFETY, TECHNICAL  
& ENGINEERING**

J

## Hose Assemblies

We encourage you to share this information with anyone who may be affected by the selection, installation, maintenance, or use of any hose assembly. Always use quality products to BE SAFE.

Hose assemblies must be inspected prior to each use. Worn out fittings, attachment devices, hose, and accessory items must be replaced. Retaining and safety devices such as clips, cables, or chains must be used. Clamps must be checked regularly to the specified torque found in the Dixon™ literature. Under no circumstance should any coupling be disconnected while under pressure unless the coupling is specifically designed to do so. Disconnecting couplings under pressure could result in serious injury or death and destruction of property and equipment.

### For all hose assemblies in use:

#### **Beware:**

Hose assemblies can be dangerous when used improperly or in the wrong application. The maximum working pressure shown on the hose is not an indication of the working pressure of the assembly.

Based on the hose, fittings, and attachment method used, all assemblies should be permanently marked with the designed working pressure and the intended media. The assembly working pressure should be permanently displayed.

Hose assemblies must be used for the intended service only. Never alter manufactured product or substitute component parts.

#### **Eliminate:**

Eliminate hazardous conditions by inspecting, maintaining, and testing hose assemblies.

Dixon™ recommends that all hose assemblies be tested in accordance with the hose manufacturers' specifications. The application determines the regularity of the re-testing schedule.

#### **Secure:**

Secure and inspect hose, fittings, clamping devices, and safety accessories before each use. Never take for granted that the coupling or attachment devices are properly installed.

#### **Always:**

Always inspect and re-tighten the bolts of any bolt-style clamping device to the manufacturers' torque specifications.

#### **Fittings:**

Hose and clamping devices that are worn out or damaged must be removed from service.

#### **Educate:**

Educate your employees about the proper use, care, and potential hazards of hose assemblies.

Take advantage of Dixon™'s free Safety Survey Program and the follow up Training Seminar to assist setting up your own inspection program. Contact Dixon™ if you have any questions on applications, use, or assembly.

## STAMPED

When fabricating and specifying hose assemblies, ask the following questions:

### Size:

What is the I.D. (Inside Diameter) of the hose? What is the O.D. (Outside Diameter) of both ends of the hose? What is the overall length of the assembly required?

### Temperature:

What is the temperature range of the media (product) that is flowing through the hose assembly?  
What is the temperature range of the environment that surrounds the outside of the hose assembly?

### Application:

How is the hose assembly actually being used? Is it a pressure application? Is it a vacuum (suction) application? Is it a gravity flow application? Are there any special requirements that the hose assembly is expected to perform? Is the hose being used in a horizontal or vertical position? Are there any pulsations or vibrations acting on the hose assembly?

### Media:

What is the media/material that is flowing through the hose assembly?  
Being specific is critical. Check for: Abrasive materials, chemical compatibility, etc.

### Pressure:

What is the maximum pressure including surges (or maximum vacuum) that this hose assembly will be subjected to? Always rate the maximum working pressure of your hose assembly by the lowest rated component in the system.

### Ends:

What couplings have been requested by the user? Are they the proper fittings for the application and hose selected?

### Dixon™:

Dixon™ recommends that, based on the hose, fittings, and attachment method used, all assemblies be permanently marked with the designed working pressure and intended media. Do not use other manufacturers' fittings or ferrules with Dixon™ products due to the differences in dimensions and tolerances. We also recommend that all hose assemblies be tested frequently.



All hose assemblies compliant with Pressure Equipment Directive 2014/68/EU

## Hose Assemblies

### Pressure Ratings

Pressure ratings for couplings, as stated in this catalogue, are based upon ambient temperature **21°C (70°F)** applications with:

- True hose ID
- New Dixon™ supplied couplings
- New Dixon™ supplied clamps
- New Dixon™ quality hose
- Proper installation by a qualified assembler using Dixon™ procedures and equipment

Temperature can affect coupling retention. For temperatures other than ambient **21°C (70°F)**, contact Dixon™.

### Product Selection

Many of the products in this catalogue are used in hose assemblies in a variety of applications. The safety of any hose assembly rests on the proper selection, installation, testing, and use of each product.

The safe use of any product in this catalogue is dependent upon the correct selection of the hose, fittings, and method of attachment. To ensure a correct selection, the user must inform the distributor of the application and pressure involved when ordering hose assemblies. The use of the acronym STAMPED (Size, Temperature, Application, Media, Pressure, Ends, Dixon™) will help in the proper selection of hose assembly components. The selection of couplings and clamping devices is the responsibility of the purchaser or user based upon the hose manufacturers' recommendations. If the purchaser or user is uncertain about the use or application of a product, Dixon™ can provide information including test results (if available), coupling and clamping recommendations, and other data to assist with proper product selection.

### Installation

To achieve a safe and reliable assembly, proper installation procedures must be followed. Each component of the assembly plays a part in determining these procedures. The purchaser or user must follow proper procedures. If the purchaser or user has any questions regarding installation please contact Dixon™.

### Testing

Dixon™ recommends that all hoses assemblies be tested in accordance with the hose manufacturers' recommendations.

### Re-testing and Inspection

Dixon™ recommends inspection and re-testing of hose assemblies on a regular and consistent basis in accordance with the hose manufacturers' recommendations. The application determines the regularity of the inspection and re-testing schedule. Any worn-out or damaged hoses and fittings or missing safety devices should be replaced immediately. Bolt-style clamps must be checked and retightened on a regular and consistent basis.

J



Incorrect use or worn fittings and clamps can cause serious injury.



## Hose Assemblies

"The very properties that make compressed gases useful in almost every area of modern life can also make them dangerous when mishandled. Years of experience with compressed gases have led to practices and equipment which, if employed, result in complete safety."

(source: Handbook of Compressed Gases)

All hose assemblies should be viewed as potential hazards. This document is designed to inform and educate anyone who manufactures, specifies, supplies, purchases, assembles, uses, maintains, or tests any hose assembly or its component parts. The proper selection and maintenance of hose, couplings, attachment devices, and accessories is imperative.

It is the end user's responsibility to inform the distributor of the application and any special conditions that the hose assembly must meet. It is the distributor's responsibility to supply the proper assembly for the intended application.

Accidents and down time may occur if hose assemblies are not properly selected for the specific application. The performance and safety of the assembly is affected by the quality of the individual components. The use of the STAMPED method will help in the proper selection of the hose assembly components. When in doubt, Dixon™ is available to recommend the correct coupling.

## Air Hose Couplings

Air can be one of the most dangerous forms of energy because it is used in so many applications, and when mishandled it can have more serious consequences than fluids. Air as a gas is compressible (fluids press only against hose or vessel walls and lose little volume under pressure). When pressurised air releases suddenly, it does so with explosive force and can cause rapid hose whip, which can cause serious physical harm to personnel or damage to nearby objects. This is why selecting the correct hose and couplings for air lines, and their proper installation and maintenance, is so important. Never take for granted that a coupling is connected correctly or that a clamp is fully tightened on an air hose - check it regularly and use safety devices.

## Steam & Gas

The same rules apply for steam and gas as they do for air. As steam and gas are inherently more hazardous, personnel should treat the hose and couplings on these lines with more care and respect. Checking clamp tightness is very important with steam hose, where it is not unusual for clamps to loosen in service, in which case they **MUST BE RETIGHTENED!** Safety devices should also be used. Hose assemblies for steam must only use components specifically nominated for steam service.

## Fluid Hose Couplings

Again, nothing should be taken for granted. In particular check clamps for tightness each time the lines are used, especially when petroleum products or other hazardous liquids are involved. When large diameter hose is suspended, it can be quite dangerous if it drops unexpectedly due to a coupling "pull-out" or sudden disconnection. A heavy fitting or clamp, plus the weight of the hose itself falling from any height can cause injuries or damage. Be sure to use safety devices.

## All Hose Assemblies

All hose assemblies should be treated with respect and as a potential hazard. Worn-out fittings should be replaced. Retaining devices such as clips, cables, or chains should be used, and clamps should be checked regularly. Under no circumstances should any coupling be disconnected while under pressure unless the coupling is specifically designed to do so. Disconnecting couplings under pressure could result in serious injury or death and destruction of property and equipment.



### WARNING

Improper selection, care, use, maintenance of hose couplings, accessory items, and failure to use these procedures can result in serious injury or death and destruction of property and equipment.

## Hose Assemblies

To provide a complete service to its customers, Dixon™ has made considerable investment in its extensive in-house hose assembling capabilities, underpinned by a traceable quality system in accordance with BSEN ISO 9001:2008 and compliance with PED 2014/68/EU. The capability is supported by a huge inventory of couplings to produce hose assemblies utilising the following methods:

### Rubber, PTFE\* and Composite\*\*

- Internal expansion (IX) 25mm to 305mm nominal bore
  - External crimp (EC) 6mm to 102mm nominal bore
  - External swage (ES) 25mm to 102mm nominal bore
- \* EC only, \*\*EC & ES only

### Rubber and PVC

- Heavy-duty double bolt clamps
- Band and pre-formed band clamps
- Heavy-duty T-Bolt clamps
- Hi-Torque clamps
- Compression rings
- BSEN 14420-3:2004 safety clamps (formerly DIN 2817 etc)

### Metal

- Welding procedures are in accordance with ASME IX and BSEN 288
- Welders qualifications to ASME IX and BSEN 287

## Test procedures and additional services

Our pressure testing facilities include:

- Pneumatic leak test (air under water)
- Hydrostatic proof and burst tests up to **380 bar (5510 PSIG)**
- Hydrostatic proof and burst test certification can be supplied with a chart recorder read-out if requested at time of order placement
- Assemblies can also be hydrostatically tested using de-mineralised water (maximum chloride content of 30mg/l) when requested
- Liquid penetrant inspection to ASME V article 6 & ASME B31.3 table 341.3.2
- Liquid penetrant technicians qualified to PCN level 2
- Sub-contract x-ray in accordance with ASME V article 6 with acceptance level to ASME B31.3 table 341.3.2
- Endoscope
- Chemical etching
- Tagging

## Pressure Equipment Directive 2014/68/EU

The Pressure Equipment Directive 2014/68/EU was embraced by the European Parliament and the Council of Ministers on 29 May 1997, enforced a further two years later on 29 November 1999 but with a three year grace. Whereby compliance to its requirements were elective until 29 May 2002.

Failure to comply could result in prosecution by way of a fine, prison sentence, or both.

On the whole the PED is legislation across the European Environment Agency (EEA), which requires that all pressure equipment must be fully compliant with regards to particular aspects such as material selection, design, manufacturing techniques, personnel qualification, testing requirements, product marking, and user liability.

The Directive covers pressure equipment and assemblies with a maximum allowable pressure PS greater than 0.5 bar and includes such equipment as reaction vessels, industrial pipe-work, pressurised storage containers, heat exchangers, pressure accessories, and safety devices. The PED's interpretation of an assembly being several pieces of pressure equipment assembled to form an integrated system.

PED accreditation, where applicable, allows for the active placing of the CE mark on pressure equipment and is a given passport to free trade within the EEA, without the need for statutory inspection by current Member States.

As a result, Dixon Group Europe have revised their manufacturing methodology and integrated an already efficient ISO 9001 quality management system with the Essential Safety Requirements of the PED, accredited by Lloyds Register, Notified Body Number 0038.

For further information on how this can benefit your business, please contact us on +44 (0)1772 323529.

## Metallic Hose Assembly Length Tolerances

Dimension tolerances meeting the requirements of class 1 of the EN ISO 10380 standard applies to all Dixon™ metallic hose assemblies.

- Lengths above 1 metre shall be manufactured to +3% and -1% tolerance
- Lengths below 1 metre shall to manufactured +1 and -1% corrugation

These tolerances are applicable regardless of bore size. Length below 1 metre is Dixon™'s definition of a short length.

De-rating factors will apply for elevated temperature applications. Refer to the technical section or call Dixon™ for further information.

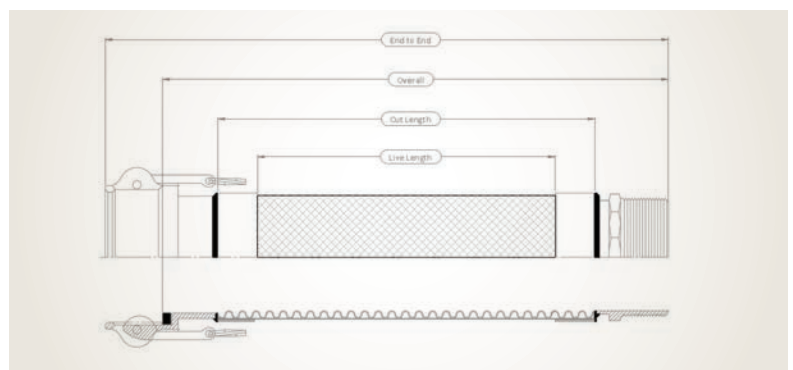
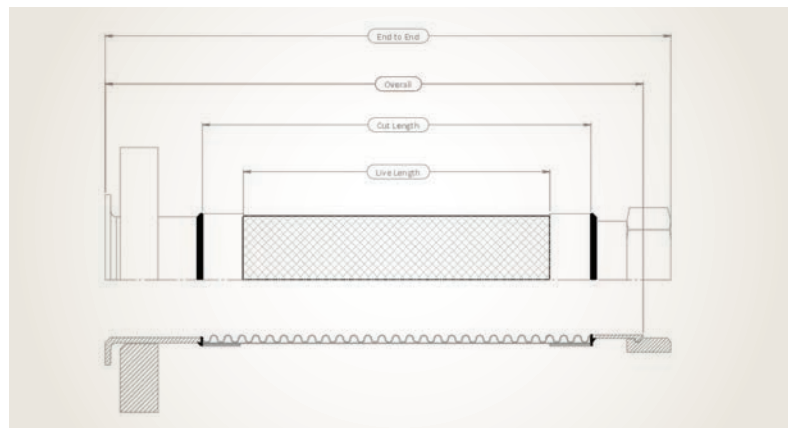

## Installation & Safety: Metallic Hose

When installed correctly within the design parameters of the hose to be used, stainless steel hose assemblies can give many years of satisfactory life. To help maximise the working life the following rules should be observed.

**Torque** - Stainless steel hose assemblies should never be subject to torque.

### Hose is subjected to torque by:

1. Twisting during installation. This can be minimised by the use of a swivel joint at one end, where the fixed fitting is tightened up first. Two spanners should be used on union fittings.
2. Twisting when flexed. The hose should be installed so that flexing takes place in one plane only and the direction of motion must be perpendicular to the centre line of the hose. Pipework must be anchored and guided at each change of direction where a hose is used to absorb pipework movement.

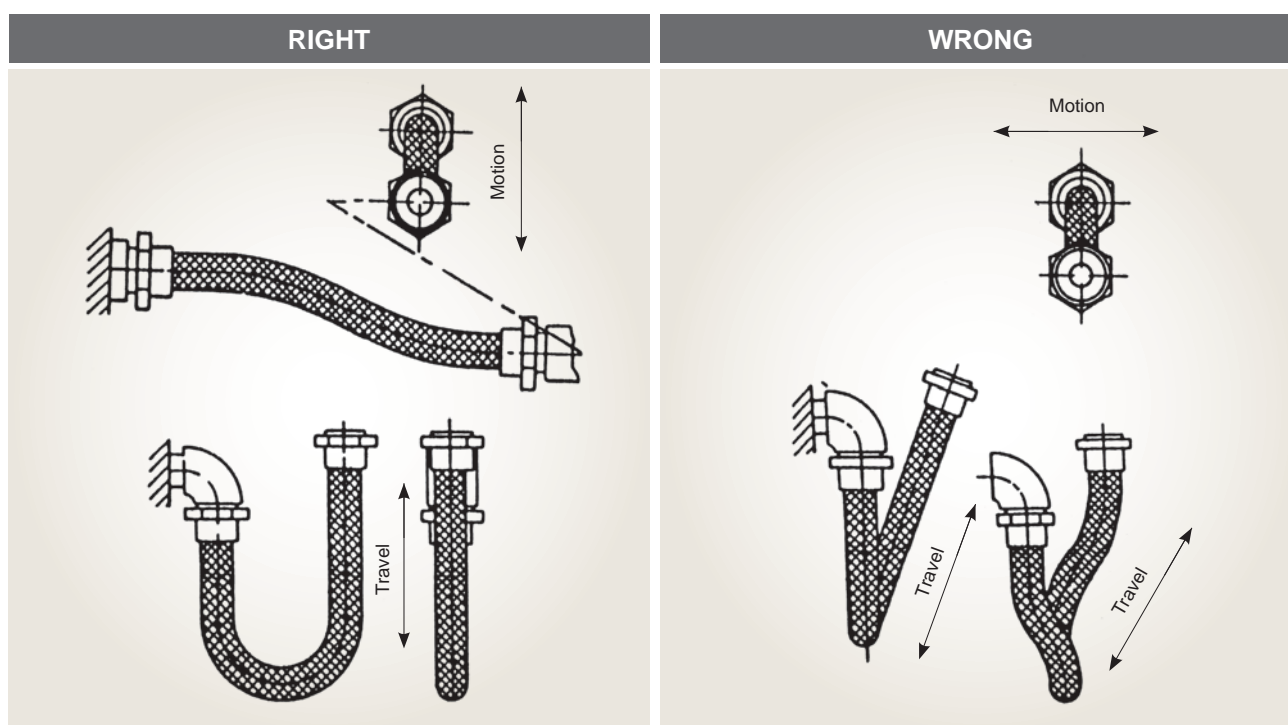

**Rubbing** - Any signs of external damage should cause the hose to be replaced. Damage to the braid will cause the pressure capacity of the hose to be compromised, possibly endangering personnel.

**Pressure** - Always refer to the maximum working pressure of the hose before installation. Always take into account the other working conditions such as temperature and pulsation.

**Pulsation or Shock Pressures** - These can be caused by the fast opening or closing of valves etc. and can cause premature failure through metal fatigue. Where this cannot be avoided the maximum working pressure of the hose should be reduced by 50%. Installation should be in a straight line with no slack on the braid.

**Small Radii** - Small radii should be avoided and the minimum centre line bend radius of the hose should always be observed. Be aware of the different bend radii for dynamic (i.e. constantly moving) and static (i.e. anti vibration) applications. The use of Parrap hose or solid elbows should be considered. If the application causes the hose to flex below the minimum bend radius near the ferrule, the use of a hose 'bend limiter' can be considered.

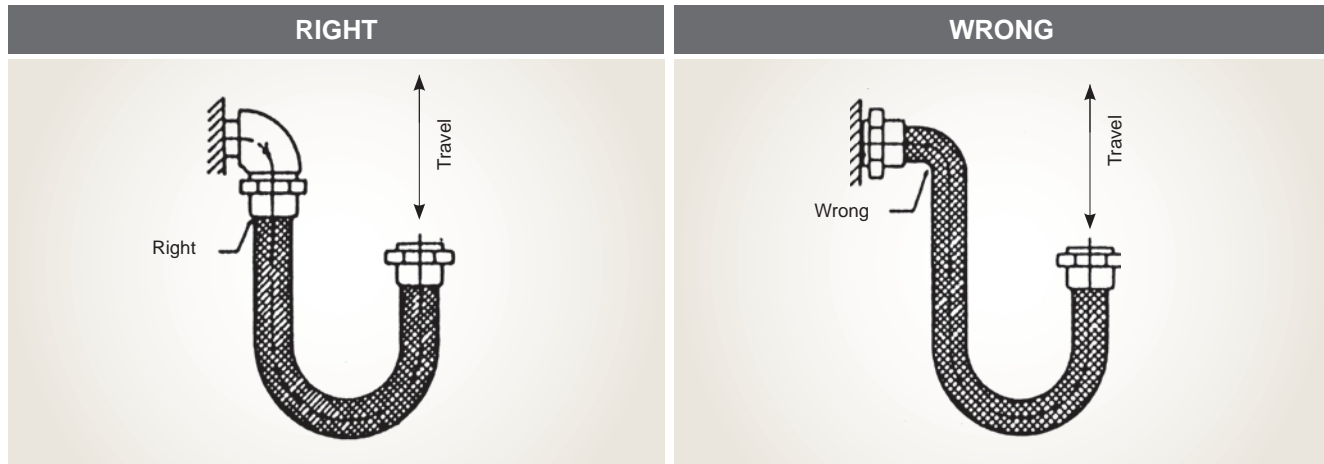

**Flow Velocity** - The convolutions can affect high flow velocities in one of two ways:

1. Turbulence. Velocities above 150 Ft/Sec for gas or 75 Ft/Sec for liquid can cause turbulence within the hose convolutions leading to metal fatigue. To overcome this, the use of the next size of hose, with or without a liner, can be effective. For hoses bent through 90° the above flows should be reduced by 50%; for 45° reduce by 25%.
2. Pressure Loss. As a rough guide it can be assumed that the pressure loss in a convoluted stainless-steel hose is twice that for new, welded steel pipe. This means that an increase in the bore size of 15% will reduce the pressure loss to that of the steel pipe.

**Temperature** - When operating at elevated temperatures, a 'correction' factor should be applied to reflect the changed state of the hose material.

Stainless Steel Core Grade 321 (1.4541)										
Temperature °C	-200	-150	-100	-50	0	50	100	150	200	250
Factor	1	1	1	1	1	0.93	0.83	0.78	0.74	0.70
Temperature °C	300	350	400	450	500	550	600	650		
Factor	0.66	0.64	0.62	0.60	0.59	0.58	Enquire	Enquire		

Stainless Steel Core Grade 316 (1.4404)										
Temperature °C	-200	-150	-100	-50	0	50	100	150	200	250
Factor	1	1	1	1	1	0.90	0.73	0.67	0.61	0.58
Temperature °C	300	350	400	450	500	550	600	650		
Factor	0.53	0.51	0.50	0.49	0.47	0.47	Enquire	Enquire		

The above information is intended as a guide only, and as such the above specifications cannot be held to be mandatory. Dixon™ reserves the right to change and modify designs and specification without notice.



## Dixon™ Flexible Hose Assembly Installation, Maintenance, and Safety Guidelines

Provided the correct and full conditions of use have been given at the time of order placement and the assembly is subsequently installed within its design parameters, the flexible hose assembly (FHA) or pressure equipment can give many years of satisfactory service life. To help maximise this service life the following guidelines should be followed.

### 1. Integrity

The integrity of FHAs is very dependent on the correct selection of hose product and adherence to the installation procedures. Dixon™ suggests that all personnel required to install, inspect, and maintain FHAs should be formally authorised and fully conversant with the appropriate installation, test and maintenance procedures, failure criteria, etc.

### 2. Safety Considerations

- FHAs should not be used where it is safer to install permanent pipework.
- Design – FHAs suitability with system's piping and equipment.
- Application – suitability of the FHA in relation to media, pressures, temperature, and when used in suction applications, ability to withstand vacuum.
- External Environment - FHAs should only be used for duties for which they are approved.
- Installation - FHAs should be adequately supported and installed to the manufacturer guidelines, as applicable and consistent with the best practice principles contained within this guidance document.
- Length – FHAs should be kept to a minimum, consistent with flexibility and required function.
- Electricity – dangers of static electricity in the application and effects on all components associated with FHAs continuity requirements.

### 3. Vibration/Movement

FHAs may eliminate the transmission of vibration or movement in a specific application. FHAs will only efficiently eliminate the transmission of vibration, movement, or noise if the adjacent pipework is properly anchored on the downstream side of the hose. In the worst cases, failure to ensure this can lead to uncontrolled movement of the FHAs and premature failure.

### 4. Misalignment

FHAs should not be used as a remedy for poor design or installation, e.g. to correct misalignment of rigid components.

### 5. Degradation

Degradation of FHAs can be accelerated due to heat, environmental conditions, or contamination of the outer coverings and braids due to chemicals, ultraviolet light, ozone, salt, water, etc. It should be noted that the fluid composition could change over the expected lifecycle.

Note: Heat tracing and insulation can considerably accelerate any corrosion mechanisms.

### 6. Storage

All FHAs should be stored in clean, dry conditions, and hoses of rubber and composite construction should be kept in a cool atmosphere protected from direct sunlight. Some hose linings, if not protected prior to putting into service, have a finite shelf-life.

## **Dixon™ Flexible Hose Assembly Installation, Maintenance, and Safety Guidelines (cont.)**

### **7. Cleaning and Flushing**

All components used in a system that includes a FHA should be cleaned and flushed prior to use, to prevent debris being carried, damaging the liner of the hose.

### **8. Operations, Maintenance, Inspection, and Testing**

Users should ensure that all FHAs are subject to a periodic inspection routine. Only authorised, competent personnel should be permitted to install, inspect, and maintain flexible hose lines. Visual inspection of the hose body for cuts, kinks, bulges, signs of abrasion, corrosion products, etc. Particular attention should be focused close to the end coupling for signs of over-bending or leakage.

### **9. Changing Conditions**

The user should be aware of changing conditions, which may move the FHAs away from the original design intent. Changes can include, but are not limited to: pressure, temperature, flow, media etc.

### **10. User's/Purchaser's Responsibility to Define Requirements**

The user or purchaser of any FHA should always consider and properly define the application of the FHA by referring to STAMPED:

STAMPED: Size, Temperature, Application, Media, Pressure, Ends, Dixon™. In addition, consider static or dynamic use of the hose and the working environment.



## Installation

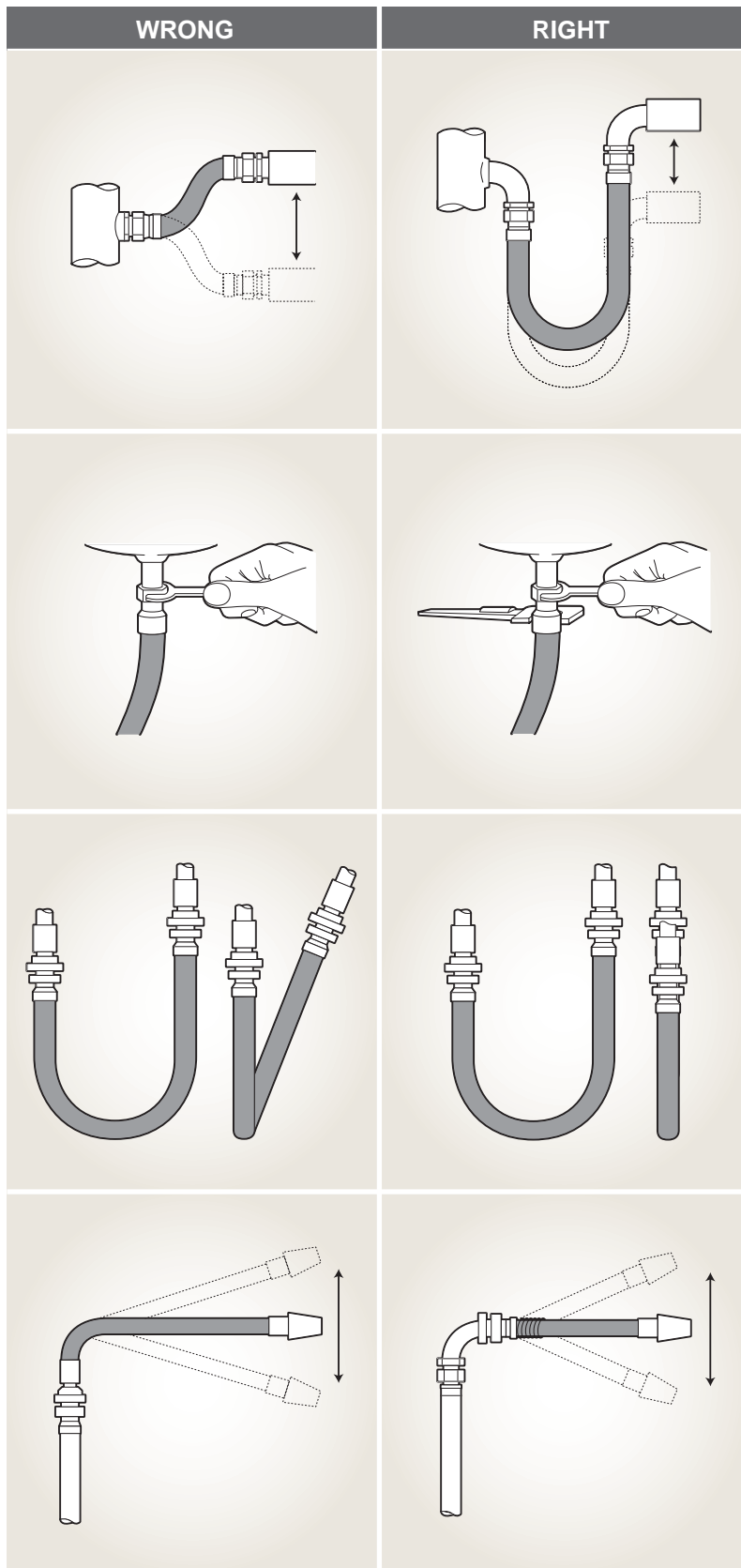

Flexible Hose Assemblies (FHAs) should always be handled with reasonable care and should not be subjected to over straining. The design of hose supports and saddles should be to ensure that the minimum bend radius is not compromised.

FHAs should never be forcefully deformed, crushed, twisted, or subject to flow shut-off by kinking.

Avoid routing or dragging FHAs over sharp or abrasive surfaces.

FHAs should not be allowed to hang between equipment that can move and cause FHAs to become over-stretched or bent.

The following considerations should be taken into account before the FHA is installed in either a static or flexing application:

- It is essential that the mating couplings are completely free from foreign matter, burrs etc. Damage, corrosion, or contamination to the mating surfaces will cause joint failure in service.
- The installed bend radius of the FHA must not be less than the minimum bend radius specified.
- Union nuts should be hand tightened at both ends and the FHA be allowed to adopt its natural position prior to tightening.
- FHAs should not be installed in a twisted condition, since this puts unbalanced tension on the hose and reduces the working life of the assembly.
- FHAs should not be installed in applications where compression, axial extension, or torsion could occur.
- Dixon™ always recommends the use of a 'King' Hose Safety Restraint Cable on FHAs.



Note: Poor installation can cause leaks and contamination.



## Taking Flexible Hose Assemblies Out Of Service

FHAs that have been taken out of service for a temporary period to be subsequently reused at another time should always have the media drained from the hose. The FHA should also be cleaned and flushed if required.

The FHA should then be stored in clean, dry conditions. FHAs of rubber and composite construction should be kept in a cool atmosphere protected from direct sunlight.

FHAs that have been identified as being unfit for any purpose should have the end couplings removed and the main carcass of the hose marked as 'Scrap'. It should then be disposed of in line with regional disposal segregation procedures, taking into account decontamination requirements.

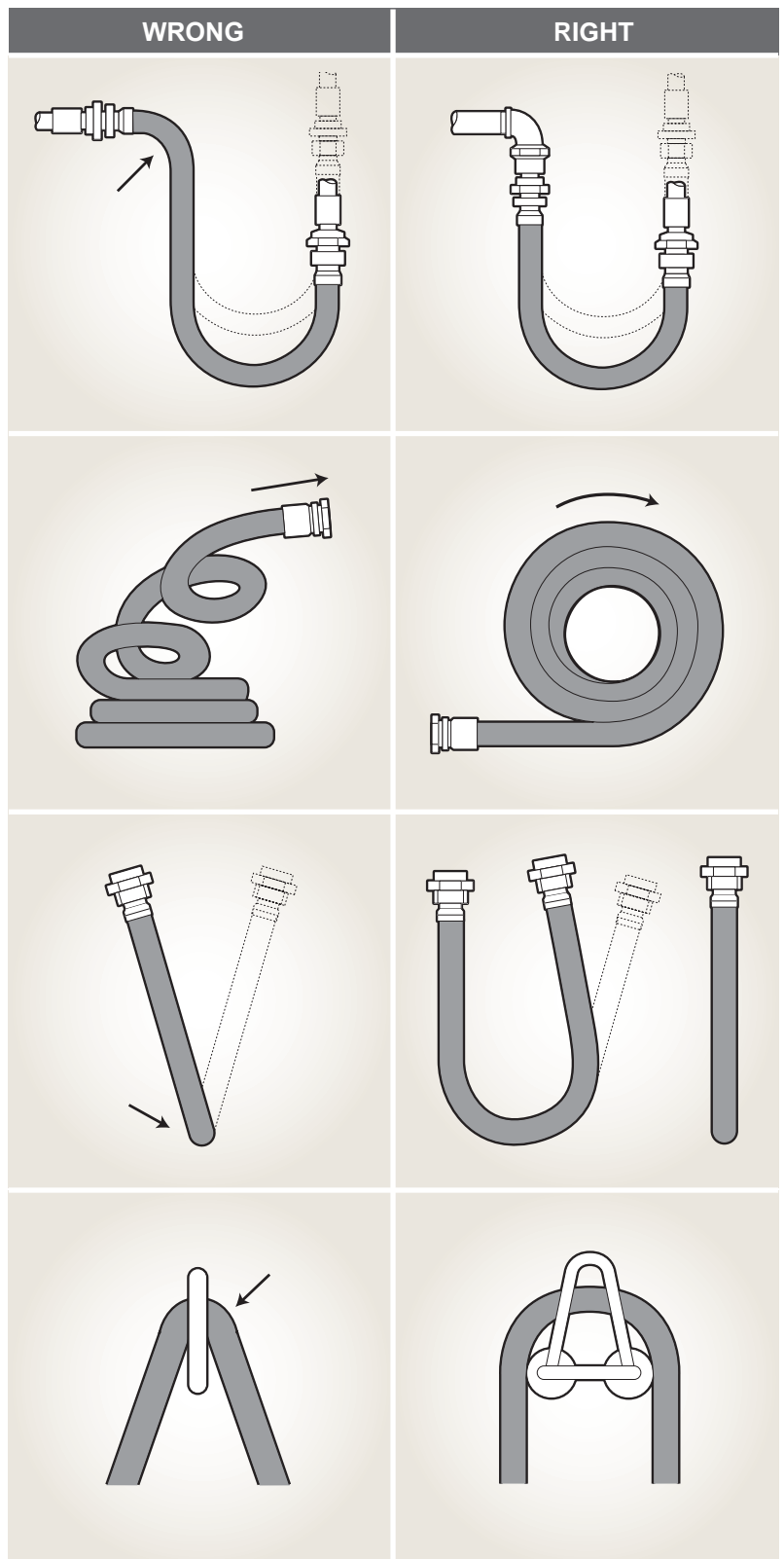

For additional advice regarding installation, maintenance, and the safe operational use of flexible hose assemblies, please contact a member of the Dixon™ sales team.

BE SAFE - ALWAYS SPECIFY DIXON™ PRODUCT

Note: Poor installation reduces hose life and can be potentially hazardous.

## Pressure Recommendations

The images shown on these two pages are provided to assist in coupling and clamp or ferrule identification for the pressure recommendation chart on pages 322-325.

### Couplings



Dixon™ Cam & Groove



Boss™ Couplings



Air King™ Universal



King™ Machined Medium Shank



King™ Machined Long Shank



Machined Short Shank

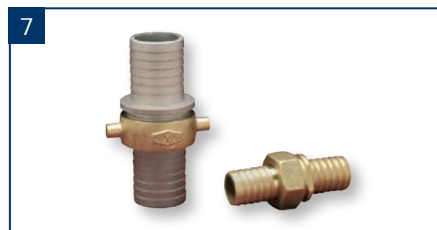

Cast Short Shank



Push-On



Reusable Brass



Holedall™ Swage / Crimp



Holedall™ Internal Expansion



Flow Chief / Sanitary



Holedall™ Internal Expansion Petroleum



King Crimp™ Couplings

## Pressure Recommendations

### ⚠ WARNING

1. The chart on pages 322-325 is intended as a guide only. It only applies to metal couplings as shown for ambient temperature **21°C (70°F)** applications with true ID hose. It assumes new Dixon™ supplied couplings, new Dixon™ supplied clamps, new quality hose and proper installation by a qualified assembler using Dixon™ procedures and equipment. Temperature can affect the coupling retention. For questions relating to temperatures other than ambient **21°C (70°F)** contact the hose manufacturer or Dixon™.
2. This chart does not apply to non-Dixon™ products, with used hose, in non-approved or unsupported applications, or in non-standard assemblies.
3. Do not use this chart if it conflicts with the hose manufacturers' recommendations.
4. All hose assemblies should be pressure tested to hose manufacturers' or Rubber Manufacturers' Association (RMA) specifications prior to being put into service.
5. Our test experience indicates that coupling retention can vary with changes in hose design. For pressure ratings other than those listed and shown, or if questions arise, please call Dixon™ for assistance.
6. All hose assembly components must be compatible with the materials and environments with which they are to come in contact.
7. Dixon™ recommends that all hose assemblies be marked with the assembly working pressure and media of the intended application. Under no circumstances should the assembly working pressure exceed the working pressure of the lowest rated component (coupling, clamp, ferrule, or hose).

## Clamps and Ferrules



Boss™ Interlocking Clamps



Air King™ Interlocking Clamps

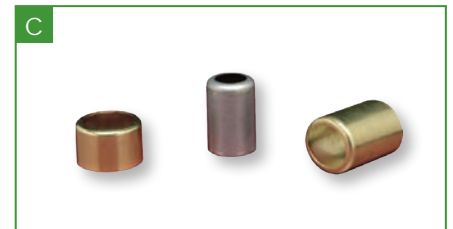

Light Duty Ferrules



Band & Buckle

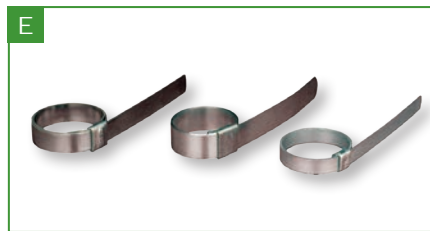

Preformed Clamps



Double Bolt Clamps



Swage / Crimp



Internal Expansion



Internal Expansion Petroleum

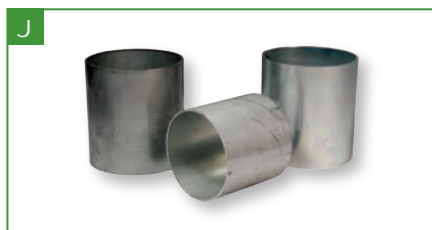

King Crimp™ Sleeve



King Crimp™ Ferrule

**Dixon™ Hose Assembly Pressure Recommendation Chart**

Mark hose assembly with pressure from this chart or the hose working pressure, whichever is lower. All pressure recommendations are in pounds per square inch (PSI)

1. This chart is intended as a guide only. It only applies to metal couplings as shown for ambient temperature **21°C (70°F)** applications with true ID hose. It assumes new Dixon™ supplied couplings, new Dixon™ supplied clamps, new quality hose and proper installation by a qualified assembler using Dixon™ procedures and equipment. Temperature can affect the coupling retention. For questions relating to temperatures other than ambient **21°C (70°F)** contact your local Dixon™ branch.
2. This chart does not apply to non-Dixon™ products, with used hose, in non-approved or unsupported applications, or in non-standard assemblies.
3. Do not use this chart if it conflicts with the hose manufacturers' recommendations.
4. All hose assemblies should be pressure tested prior to being put into service.

Hose (rubber covered)	Couplings	Clamps & Ferrules	Assembly Procedure *	Max Recommended WP PSI				
				¼"	⅜"	½"	⅝"	¾"
Air textile reinforced rubber lined	Air King™ Universal	Prefomed Band Clamp	2102			150	150	150
	Brass Nut & Tail - Combination Nipples	Crimp	2304	200	150	150	100	100
	Machined - Short Shank	Prefomed Band Clamp	2100-2101			150	100	100
	Reusable - Brass	N/A	2305	250	250	250		
	King™ Machined - Medium Shank	Prefomed Band Clamp	2100-2101			250	200	200
	King™ Machined - Long Shank	Prefomed Band Clamp	2100-2101			300	300	300
	King Crimp™ ST - Ferrule	King Crimp™ Ferrule	4201					
Air textile or wire reinforced rubber lined	Air King™ Universal	Air King™ or Boss™ Interlocking Clamp	2000		150	150		150
	Air King™ Universal	Swage/Crimp	See ADPL			150		150
	Boss™ Couplings	Boss™ Interlocking Clamp	2000-2004	600	600	600		600
	Holedall™ Swage/Crimp	Swage/Crimp	see Ram Manual	600	600	600		600
	King Crimp™ ST - Ferrule	King Crimp™ Ferrule	4201					
Asphalt & Hot Tar	Boss™ Couplings	Boss™ Interlocking Clamp	2001-2002					
Chemical plastic lined for liquid service	King™ Machined - Medium Shank	Prefomed Band Clamp	2100-2101			125		125
	King™ Machined - Medium Shank	Band & Buckle	2104					
	King™ Machined - Long Shank	Prefomed Band Clamp	2100-2101			150		150
	King™ Machined - Long Shank	Band & Buckle	2104					
	Andrews/Boss-Lock™ Cam & Groove	Prefomed Band Clamp	2100-2101			150		150
	Andrews/Boss-Lock™ Cam & Groove	Band & Buckle	2104					
	Andrews/Boss-Lock™ Cam & Groove	Swage/Crimp	see Ram Manual					250
	Holedall™ Swage/Crimp	Swage/Crimp	see Ram Manual			600		600
	King Crimp™ ST - Ferrule	King Crimp™ Ferrule	4201					
	King Crimp™ ST - Sleeve	King Crimp™ Sleeve	4200					
	King Crimp™ Cam & Groove - Ferrule	King Crimp™ Ferrule	4201					
King Crimp™ Cam & Groove - Sleeve	King Crimp™ Sleeve	4200						
Chemical rubber lined for liquid service	King™ Machined - Medium Shank	Prefomed Band Clamp	2100-2101			125		125
	King™ Machined - Medium Shank	Band & Buckle	2104					
	King™ Machined - Long Shank	Prefomed Band Clamp	2100-2101			150		150
	King™ Machined - Long Shank	Band & Buckle	2104					
	Andrews/Boss-Lock™ Cam & Groove	Prefomed Band Clamp	2100-2101			150		250
	Andrews/Boss-Lock™ Cam & Groove	Band & Buckle	2104					
	Andrews/Boss-Lock™ Cam & Groove	Swage/Crimp	see Ram Manual					250
	Boss™ Couplings	Boss™ Interlocking Clamp	2000-2004			600		600
	Holedall™ Internal Expansion	Internal Expansion	see Ram Manual					
	King Crimp™ ST - Ferrule	King Crimp™ Ferrule	4201					
	King Crimp™ ST - Sleeve	King Crimp™ Sleeve	4200					
	King Crimp™ Cam & Groove - Ferrule	King Crimp™ Ferrule	4201					
	King Crimp™ Cam & Groove - Sleeve	King Crimp™ Sleeve	4200					
	Holedall™ Swage/Crimp	Swage/Crimp	see Ram Manual			600		600
Food Grade conforming to 3A	Flow Chief Sanitary	Internal Expansion	see Ram Manual					
Food Grade rubber lined	King™ Machined - Medium Shank	Prefomed Band Clamp	2100-2101			125		125
	King™ Machined - Medium Shank	Band & Buckle	2104					
	Andrews/Boss-Lock™ Cam & Groove	Prefomed Band Clamp	2100-2101			150		250
	Andrews/Boss-Lock™ Cam & Groove	Band & Buckle	2104					
	Andrews/Boss-Lock™ Cam & Groove	Swage/Crimp	see Ram Manual					250
	Holedall™ Internal Expansion Holedall™	Internal Expansion	see Ram Manual					
	Swage/Crimp	Swage/Crimp	see Ram Manual			600		600
	King Crimp™ ST - Ferrule	King Crimp™ Ferrule	4201					
	King Crimp™ ST - Sleeve	King Crimp™ Sleeve	4200					
	King Crimp™ Cam & Groove - Ferrule	King Crimp™ Ferrule	4201					
	King Crimp™ Cam & Groove - Sleeve	King Crimp™ Sleeve	4200					
Layflat	Bauer Coupling Standard	Wire Whipping						
	Bauer Coupling	Prefomed Band Clamp						
	Camlock	Prefomed Band Clamp						
Material Handling rubber lined	Cast Short Shank	Prefomed Band Clamp	2100-2101					
	Cast Short Shank	Band & Buckle	2104					

\* Procedures can be found on [europe.dixonvalve.com](http://europe.dixonvalve.com) or by calling +44 (0)1772 323529.



- Our test experience indicates that coupling retention can vary with changes in hose design. For pressure ratings other than those listed and shown, or if questions arise, please contact your local Dixon™ branch for assistance.
- All hose assembly components must be compatible with the materials and environments with which they are to come in contact.
- Dixon™ recommends that all hose assemblies be marked with the assembly working pressure and media of the intended application. Under no circumstances should the assembly working pressure exceed the working pressure or the working temperature of the lowest rated component (coupling, clamp, ferrule, or hose).
- For further safety information, refer to this section of the catalogue, or contact your local Dixon™ branch.

	Max Recommended WP PSI								Special Notes	
	1"	1½"	1½"	2"	2½"	3"	4"	5"		6"
150 100 100										(2) bands on 5/8" or larger; Must use mating Dixon™ Air King™ fittings with safety clip installed.
150 300 400			350	300		300	300		230	(2) bands on 1/2" to 1" (13) crimp length would be full length
150 150 600 600 400										Must use mating Dixon™ Air King™ fittings with safety clip installed. Coupling and ferrule are sold assembled. Must use mating Dixon™ Air King™ fittings with safety clip installed.
200	200	200	200	200	200	200	200	200	200	(13) crimp length would be full length Consult Dixon™
125 150 250 250 600 400 400 250 250	125 150 250 250	125 150 250 250	125 150 250 250	75 125 150 150	75 100 100 150	50 75 75 125	50 75 75 100			(3) bands on 3" and 4"; (2) bands on 1½" to 2½"; (1) band on the rest; except for KHN, KRN and PF nipples (3) bands on 3" and 4"; (2) bands on 1½" to 2½"; (1) band on the rest; except for KHN, KRN and PF nipples (5) bands on 3" and 4"; (4) bands on 2" and 2½"; (3) bands on 1¼" and 1½"; (2) bands on the rest; except for KHN and KRN nipples (5) bands on 3" and 4"; (4) bands on 2" and 2½"; (3) bands on the rest; except for KHN and KRN nipples Requires properly matched Stem and Ferrule.
600 400 400 250 250	600 300 250	600 300 250	600 300 250	600 250	450 200 150	450 300 150	250 175 150		230 75 75 75	(13) crimp length would be full length (13) crimp length would be full length (13) crimp length would be full length (13) crimp length would be full length
125 150 250 250 600 800 400 400 250 250 600	125 150 250 250	125 150 250 250	125 150 250 250	75 100 150 150	75 100 100 150	50 75 75 125	50 75 75 110			(3) bands on 3" and 4"; (2) bands on 1½" to 2½"; (1) band on the rest; except for KHN, KRN and PF nipples (3) bands on 3" and 4"; (2) bands on 1½" to 2½"; (1) band on the rest; except for KHN, KRN and PF nipples (5) bands on 3" and 4"; (4) bands on 2" and 2½"; (3) bands on 1¼" and 1½"; (2) bands on the rest; except for KHN and KRN nipples (5) bands on 3" and 4"; (4) bands on 2" and 2½"; (3) bands on the rest; except for KHN and KRN nipples Requires properly matched stem and ferrule. Consult Dixon™ for ratings on IXF48-3 to IXF48-5 and IXF64-2 to IXF64-5 ferrules.
600 400 400 250 250	600 300 250	600 300 250	600 250	600 250	450 200	450 150	250 175		230 75 75 75	(13) crimp length would be full length (13) crimp length would be full length (13) crimp length would be full length (13) crimp length would be full length
125 250 250 600 400 400 250 250	125 250 250	125 250 250	125 250 250	75 150 150	75 125 125	50 125 100	50 100 75	25 75 75		(4) bands on 6"; (3) bands on 3" to 5"; (2) bands on 1½" to 2½"; (1) band on the rest; except for KHN, KRN and PF nipples (4) bands on 6"; (3) bands on 3" to 5"; (2) bands on 1½" to 2½"; (1) band on the rest; except for KHN, KRN and PF nipples Requires properly matched stem and ferrule.
600 400 400 250 250	600 300 250	600 300 250	600 250	600 250	600 200	600 150	500 175	450 75	400 230 75 75	(13) crimp length would be full length (13) crimp length would be full length (13) crimp length would be full length (13) crimp length would be full length
			300	250	250	250	225		150	To be used as a set ONLY. 6" cam & groove couplings are rated to 75 PSI.
		75 75	75 75	50 50	50 50	50 50	25 25	25 25		(4) bands on 6"; (3) bands on 3" to 5"; (2) bands on 1½" to 2½" (4) bands on 6"; (3) bands on 3" to 5"; (2) bands on 1½" to 2½"



Hose (rubber covered)	Couplings	Clamps & Ferrules	Assembly Procedure *	Max Recommended WP PSI				
				¼"	⅜"	½"	⅝"	¾"
Material Handling rubber lined (continued)	King™ Machined - Medium Shank	Preformed Band Clamp	2100-2101					
	King™ Machined - Medium Shank	Band & Buckle	2104					
	King™ Machined - Long Shank	Preformed Band Clamp	2100-2101					
	King™ Machined - Long Shank	Band & Buckle	2104					
	Andrews/Boss-Lock™ Cam & Groove	Preformed Band Clamp	2100-2101					
	Andrews/Boss-Lock™ Cam & Groove	Band & Buckle	2104					
	Andrews/Boss-Lock™ Cam & Groove	Swage/Crimp	see Ram Manual					
	Holedall™ Swage/Crimp	Swage/Crimp	see Ram Manual					
	Holedall™ Internal Expansion	Internal Expansion	see Ram Manual					
	King Crimp™ ST - Ferrule	King Crimp™ Ferrule	4201					
King Crimp™ ST - Sleeve	King Crimp™ Sleeve	4200						
King Crimp™ Cam & Groove - Ferrule	King Crimp™ Ferrule	4201						
King Crimp™ Cam & Groove - Sleeve	King Crimp™ Sleeve	4200						
Material Handling no helical wire rubber lined	Cast Short Shank	Double Bolt Clamp	2201					
	King™ Machined - Medium Shank	Double Bolt Clamp	2201					
	King™ Machined - Long Shank	Double Bolt Clamp	2201					
	King Crimp™ ST - Ferrule	King Crimp™ Ferrule	4201					
	King Crimp™ ST - Sleeve	King Crimp™ Sleeve	4200					
	King Crimp™ Cam & Groove - Ferrule	King Crimp™ Ferrule	4201					
	King Crimp™ Cam & Groove - Sleeve	King Crimp™ Sleeve	4200					
Material Handling cement rubber lined	Boss™ Couplings	Boss™ Interlocking Clamp	2000-2004					
	Holedall™ Swage/Crimp	Swage/Crimp	see Ram Manual					
	Holedall™ Internal Expansion	Internal Expansion	see Ram Manual					
Petroleum Transfer	King™ Machined - Medium Shank	Preformed Band Clamp	2100-2101			125		125
	King™ Machined - Medium Shank	Band & Buckle	2104					
	King™ Machined - Long Shank	Preformed Band Clamp	2100-2101			150		150
	King™ Machined - Long Shank	Band & Buckle	2104					
	Andrews/Boss-Lock™ Cam & Groove	Preformed Band Clamp	2100-2101			150		250
	Andrews/Boss-Lock™ Cam & Groove	Band & Buckle	2104					
	Andrews/Boss-Lock™ Cam & Groove	Swage/Crimp	see Ram Manual					250
	Holedall™ Internal Expansion	Internal Expansion	see Ram Manual					
	Holedall™ Swage/Crimp	Swage/Crimp	see Ram Manual			600		600
	King Crimp™ ST - Ferrule	King Crimp™ Ferrule	4201					
King Crimp™ ST - Sleeve	King Crimp™ Sleeve	4200						
King Crimp™ Cam & Groove - Ferrule	King Crimp™ Ferrule	4201						
King Crimp™ Cam & Groove - Sleeve	King Crimp™ Sleeve	4200						
Air Craft Refueling conforming to API 1529	Holedall™ Internal Expansion - Petroleum	Internal Expansion - Petroleum	see Ram Manual					
Push-On	Push-On	N/A	2001-2002	175	175	175	175	175
Steam	Boss™ Couplings	Boss™ Interlocking Clamp	2000-2004			250		250
Water	Air King™ Universal	Preformed Band Clamp	2100-2101			150	150	150
	Air King™ Universal	Air King™ or Boss™ Interlocking Clamp	2000-2001		150	150		150
	Machined - Short Shank	Preformed Band Clamp	2100-2101			150	100	100
	Machined - Short Shank	Crimp	2304	200	150	150	100	100
	Cast Short Shank	Preformed Band Clamp	2100-2101			150	100	100
	Cast Short Shank	Band & Buckle	2104					
	King™ Machined - Medium Shank	Preformed Band Clamp	2100-2101			250	200	200
	King™ Machined - Long Shank	Preformed Band Clamp	2100-2101			300	300	300
	Andrews/Boss-Lock™ Cam & Groove	Preformed Band Clamp	2100-2101			150		250
	Andrews/Boss-Lock™ Cam & Groove	Band & Buckle	2104					
	Andrews/Boss-Lock™ Cam & Groove	Swage/Crimp	see Ram Manual					250
	Boss™ Couplings	Boss™ Interlocking Clamp	2000-2002	600	600	600		600
	Holedall™ Swage/Crimp	Swage/Crimp	see Ram Manual	600	600	600		600
King Crimp™ ST - Ferrule	King Crimp™ Ferrule	4201						
King Crimp™ ST - Sleeve	King Crimp™ Sleeve	4200						
King Crimp™ Cam & Groove - Ferrule	King Crimp™ Ferrule	4201						
King Crimp™ Cam & Groove - Sleeve	King Crimp™ Sleeve	4200						
Water no helical wire	Cast Short Shank	Double Bolt Clamp	2201					
	King™ Machined - Medium Shank	Double Bolt Clamp	2201					
	King™ Machined - Long Shank	Double Bolt Clamp	2201					
	King Crimp™ ST - Ferrule	King Crimp™ Ferrule	4201					
	King Crimp™ ST - Sleeve	King Crimp™ Sleeve	4200					
	King Crimp™ Cam & Groove - Ferrule	King Crimp™ Ferrule	4201					
	King Crimp™ Cam & Groove - Sleeve	King Crimp™ Sleeve	4200					

		Max Recommended WP PSI								Special Notes	
1"	1¼"	1½"	2"	2½"	3"	4"	5"	6"			
400		125	75	75	50	50	25	25	(4) bands on 6"; (3) bands on 3" to 5"; (2) bands on 1½" to 2½"; except for KHN, KRN and PF nipples		
		125	75	75	50	50	25	25	(4) bands on 6"; (3) bands on 3" to 5"; (2) bands on 1½" to 2½"; except for KHN, KRN and PF nipples		
		150	125	100	75	75			(5) bands on 3" and 4"; (4) bands on 2" and 2½"; (3) bands on the rest; except for KHN and KRN nipples		
		150	125	100	75	75			(5) bands on 3" and 4"; (4) bands on 2" and 2½"; (3) bands on the rest; except for KHN and KRN nipples		
		250	250	150	125	100	75	75			
		250	250	150	125	100	75	75			
		250	250		125	100			Requires properly matched Stem and Ferrule.		
		600	600	600	600	500	450	400			
		800	800	600	600	500			Consult factory for ratings on IXF48-3 to IXF48-5 and IXF64-2 to IXF64-5 ferrules. Internal expansion is NOT recommended for XLPE, UHMWPE and gum rubber lined hoses.		
		400	350	300		300	300	230	(13) crimp length would be full length		
400	300	250		200	175	75	(13) crimp length would be full length				
250	250	250		150	150	75	(13) crimp length would be full length				
250	250	250		125	110	75	(13) crimp length would be full length				
400		75	75	50	50	50	25	25	(3) double bolt clamps on 5" and 6"; (2) double bolt clamps on 3" to 4"; (1) double bolt clamp on the rest		
		125	75	75	50	50	25	25	(3) double bolt clamps on 5" and 6"; (2) double bolt clamps on 3" to 4"; (1) double bolt clamp on the rest; except for KHN, KRN and PF nipples		
		150	125	100	75	75			(3) double bolt clamps on all sizes; except for KHN and KRN nipples		
		350	300		300	300			(13) crimp length would be full length		
		300	250		200	175			(13) crimp length would be full length		
		250	250	250		150	150	75	(13) crimp length would be full length		
		250	250	250		125	110	75	(13) crimp length would be full length		
600	600	600	600	450	450	250	250	Cement will erode ID			
600	600	600	600	600	600	500	450	400	Cement will erode ID		
800	800	800	800	600	600	500		400	Cement will erode ID		
Consult factory for ratings on IXF48-3 to IXF48-5 and IXF64-2 to IXF64-5 ferrules.											
400		125	125	125	75	75	50	50	25	(4) bands on 6"; (3) bands on 3" to 5"; (2) bands on 1½" to 2½"; (1) band on the rest; except for KHN, KRN and PF nipples	
		125	125	75	75	50	50	25	25	(4) bands on 6"; (3) bands on 3" to 5"; (2) bands on 1½" to 2½"; (1) band on the rest; except for KHN, KRN and PF nipples	
		150	150	150	125	100	75	75		(5) bands on 3" and 4"; (4) bands on 2" and 2½"; (3) bands on 1¼" and 1½"; (2) bands on the rest; except for KHN and KRN nipples	
		150	150	125	100	75	75			(5) bands on 3" and 4"; (4) bands on 2" and 2½"; (3) bands on the rest; except for KHN and KRN nipples	
		250	250	250	250	150	125	100	75	75	
		250	250	250	150	125	100	75	75	75	
		250		250	250		125	100			Requires properly matched Stem and Ferrule.
		800	800	800	800	600	600	500		400	Consult factory for ratings on IXF48-3 to IXF48-5 and IXF64-2 to IXF64-5 ferrules.
		600	600	600	600	600	600	500	450	400	
		400		350	300		300	300		230	(13) crimp length would be full length
400		300	250		200	175		75	(13) crimp length would be full length		
250		250	250		150	150		75	(13) crimp length would be full length		
250		250	250		125	110		75	(13) crimp length would be full length		
300	300	300	300	300	300	300					
Push-on fittings should ONLY be used on push-on hose.											
250	250	250	250	250	250	250		250			
150									(2) bands on 5/8" or larger; Must use mating Dixon™ Air King™ fittings with safety clip installed.		
150									Must use mating Dixon™ Air King™ fittings with safety clip installed.		
100									(4) bands on 6"; (3) bands on 3" to 5"; (2) bands on 1½" to 2½"; (1) band on the rest		
100									(4) bands on 6"; (3) bands on 3" to 5"; (2) bands on 1½" to 2½"; (1) band on the rest		
100	75	75	75	50	50	50	25	25	(4) bands on 6"; (3) bands on 3" to 5"; (2) bands on 1½" to 2½"; (1) band on the rest		
100	75	75	75	50	50	50	25	25	(4) bands on 6"; (3) bands on 3" to 5"; (2) bands on 1½" to 2½"; (1) band on the rest		
150	150	125	75	75	50	50	25	25	(5) bands on 3" and 4"; (4) bands on 2" and 2½"; (3) bands on 1¼" and 1½"; (2) bands on the rest; except for KHN and KRN nipples		
300	300	150	125	100	75	75					
250	250	250	250	150	125	100	75	75			
250		250	250		125	100			Requires properly matched Stem and Ferrule.		
250		250	250		125	100					
600	600	600	600	450	450	250		250			
600	600	600	600	600	600	500	450	400			
400		350	300		300	300		230	(13) crimp length would be full length		
400		300	250		200	175		75	(13) crimp length would be full length		
250		250	250		150	150		75	(13) crimp length would be full length		
250		250	250		125	110		75	(13) crimp length would be full length		
400		75	75	50	50	50	25	25	(3) double bolt clamps on 5" and 6"; (2) double bolt clamps on 3" to 4"; (1) double bolt clamp on the rest		
		125	75	75	50	50	25	25	(3) double bolt clamps on 5" and 6"; (2) double bolt clamps on 3" to 4"; (1) double bolt clamp on the rest; except for KHN, KRN and PF nipples		
		150	125	100	75	75			(3) double bolt clamps on all sizes; except for KHN and KRN nipples		
		350	300		300	300			(13) crimp length would be full length		
		300	250		200	175			(13) crimp length would be full length		
		250	250	250		150	150	75	75	(13) crimp length would be full length	
		250	250	250		125	110	75	75	(13) crimp length would be full length	



## Properties of Rubber Hose

Polymer	Ethylene Propylene Diene Monomer	Natural	Neoprene	Nitrile	Styrene Butadiene	FKM	Silicone
Abbreviation	EPDM	NR	CR	NBR	SBR	FKM	SI
Hardness range ° A	20-90	30-98	25-90	20-98	25-95	60-90	30-85
Tensile strength	2	1	2	2	2	3	4
Elongation	2	1	2	2	2	2	3
Abrasion	3	2	2	2	2	3	4
Tear	2	1	2	3	3	3	4
Compression set @ 20°C (68°F)	2	2	2	2	2	1	1
Compression set @ 100°C (212°F)	2	4	3	2-3	3	1	1
Compression set @ 150°C (302°F)	3	5	5	5	5	1	1
Denting	4	1	2	3	3	2	1
Service Temp range	-56°C to 177°C (-70°F to 350°F)	-56°C to 82°C (-70°F to 180°F)	-50°C to 121°C (-60°F to 250°F)	-55°C to 100°C (-65°F to 212°F)	-55°C to 100°C (-65°F to 212°F)	-40°C to 287°C (-40°F to 550°F)	-115°C to 315°C (-178°F to 600°F)
Max service continuous temp	100°C (212°F)	70°C (158°F)	90°C (194°F)	80°C (176°F)	80°C (212°F)	220°C (428°F)	220°C (428°F)
Ozone - UV	1	4	2	4	4	1	1
Resiliency	3	1	2	3	4	3	2
Acids	1	3	3	4	4	1	2
Caustics	1	2	2	3	3	2	2
Petrol	5	5	3	1	5	1	4
Aromatic Hydro-carbons	5	5	5	3	5	1	5
Chlorine	4	4	4	4	4	1	3
Water	1	1	4	2	2	3	2
Ketones	1	1	3	4	5	5	4
Alcohol	1	1	2	1	1	4	2
Esters	1	1	3	4	1	1	3
Oils	5	5	3	1	5	1	3
Ratings	1 = Excellent; 2 = Above Average; 3 = Average; 4 = Fair; 5 = Unsuitable						

## Minimum Hose Bend Radius Recommendations



The bend radius is the radius of the arc through which a hose is bent. The minimum bend radius is the tightest arc in which a hose can be bent without kinking or otherwise damaging the hose.

Bending a hose to a tight radius imposes stresses on the structure of the hose which may cause a reduction in the performance, or in extreme cases, cause permanent damage to the hose.

The minimum bend radius that a hose will withstand depends upon many factors including the wall thickness, the presence of a wire helix, the type of reinforcing material, and the loss of performance that can be tolerated.

It is recommended that the following guides be used to determine the minimum bend radius for the range of rubber hoses.

Hose	Wire Reinforced	Non-Wire Reinforced
Up to 50mm ID	6 Times	12 Times
Over 50mm ID	8 Times	12 Times

\* Multiply hose OD by factor in chart

**\* This figure should be taken as a general guide only. If unsure contact Dixon™.**



## Basic Compounds in Rubber Hose

The following table gives the general properties of the most common rubber compounds used in hose today. It is provided as a guide therefore generalised to some degrees.

Common Name	ASTM	Composition	General Properties
Butyl	iir	Isobutylene	Excellent weathering resistance; Low permeability to air and gas; Good physical properties; Heat resistant; Poor resistance to petroleum based fluids.
CPE	cm	Chlorinated Polyethylene Elastomer	Excellent ozone and weathering resistance; Excellent oil and aromatic resistance; Excellent flame resistance.
Cross Linked Polyethylene	-	Cross Linked Polyethylene	Excellent resistance to a very wide range of solvents, chemicals, acids and oil (including aromatics).
EPDM	EPDM	Ethylene Propylene Diene Monomer	Excellent ozone, chemical, and ageing characteristics; Poor resistance to petroleum-based fluids; Very good steam resistance.
EPR	epm	Ethylene Propylene Copolymer	Excellent ozone, weathering, heat, chemical, and ageing resistance; low permeability to water; Not oil resistant.
Hypalon	csm	Chloro-Sulphonated-Polyethylene	Excellent weathering, ozone, and acid resistance; Good heat and abrasion resistance; Fair resistance to petroleum based fluids.
Natural	nr	Isoprene Natural	Excellent physical properties; Very good abrasion resistance; Acid-resistance; Not oil resistant.
Neoprene (Perbunan-C)	cr	Chloroprene	Excellent weathering resistance; Flame retarding; Good oil resistance; Good physical properties.
Nitrile (Buna-N)	nbr	Nitrile-Butadiene	Excellent oil resistance; Moderate resistance to aromatics; Good physical properties.
NVC/70	nbr/PVC	Nitrile Polyvinyl Chloride	Excellent oil and weathering resistance both for tube and cover.
Polyacrylic	acm	Acrylic Monomer	Excellent oil and tar resistance at high temperatures.
SBR	sbr	Styrene-Butadiene	Good physical properties; Good abrasion resistance; Poor resistance to petroleum based fluids.
FKM	fpm	Hexafluoro-Propylene Vinylidene Fluoride	Excellent high temperature resistance in air and oil; Very good chemical resistance.

## Water Discharge Table

This table is intended for general reference and general applicability only and should not be relied upon as the sole or precise source of information available with respect to the subject covered. The user should also refer to and follow manufacturers' specific instructions and recommendations with regard to such information, where they exist.

Flow of water through 30 metre lengths of hose, straight-smooth bore - litres per minute

PSI at Hose Inlet	Nominal Hose ID Diameters - Inch							
	1"	1¼"	1½"	2"	2½"	3"	4"	6"
20	98	178	288	609	1098	1772	3774	10959
30	121	220	356	757	1363	2203	4694	13639
40	144	257	416	886	1594	2574	5485	15933
50	163	291	469	999	1798	2903	6189	17973
60	178	322	519	1102	1984	3202	6829	19832
75	201	360	583	1245	2237	3615	7703	22372
100	235	424	681	1454	2612	4221	8998	26134
125	265	477	768	1639	2949	4762	10149	29481
150	291	526	848	1809	3252	5254	11197	32528
200	341	613	992	2112	3801	6136	13079	37998

Figures are to be used as a guide since the hose inside diameter tolerance, the type of fittings used, and orifice restriction all influence the actual discharge. Thus, variations plus or minus from the table may be obtained in actual service.

## Pressure Drop In Rubber Hoses - Water

The following tables of pressure drops and flow rates are based on experimental data and may be considered typical of most hoses. The data is based upon hoses laid out in a straight line and thus it must not be considered as an exact result that may be obtained at a given pressure. Variables such as hose fittings and bend increase the frictional losses and an estimate of their effect may be determined by adding an "equivalent length" to the hose length. Values of the equivalent length (Le) may be determined using the diameter (D) of the hose in the following relationships:

**90° Swept Elbow - Le = 20D**  
**90° Square Elbow - Le = 50D**  
**45° Square Elbow - Le = 16D**  
**Hose Coupling - Le = 05D**

## Pressure Drop (kPa per 100 metres) Water @ 20°C (70°F) Through Hose

Flow Rate (l/m)	Hose Nominal Bore (mm)												
	12.5	16	19	25	32	38	40	50	64	75	80	100	125
25	1100	470	210	50	-	-	-	-	-	-	-	-	-
50	-	2440	770	200	90	30	-	-	-	-	-	-	-
100	-	-	2660	730	300	100	55	30	-	-	-	-	-
200	-	-	-	-	1030	405	285	95	25	-	-	-	-
300	-	-	-	-	-	900	650	210	65	20	-	-	-
400	-	-	-	-	-	-	1200	370	110	40	-	-	-
500	-	-	-	-	-	-	-	580	155	70	50	-	-
1000	-	-	-	-	-	-	-	-	575	230	180	55	-
2000	-	-	-	-	-	-	-	-	-	920	600	220	45
3000	-	-	-	-	-	-	-	-	-	2125	1400	490	100
4000	-	-	-	-	-	-	-	-	-	-	-	805	190
5000	-	-	-	-	-	-	-	-	-	-	-	1390	315

**Note:** (1) Pressure drop is directly proportioned to the length of hose.  
(2) Friction is independent of pressure and proportional to velocity.

## Flow Rate of Water through Hose

Volumetric Flowrate of Water Through 100m Hose (litre/minute)														
Inlet Pressure (kpa)	Hose Internal Diameter (mm)													
	12.5	16	20	25	32	38	40	50	64	75	80	100	150	200
150	15.5	31	48	102	181	299	359	639	1145	1701	2079	3969	11482	24239
200	18.5	35	57	117	215	352	408	741	1342	2126	2457	4631	13466	28870
300	24	42	71	157	272	438	499	922	1663	2717	3071	5670	16727	35749
400	29.5	49	82	178	317	510	582	1081	1950	3189	3662	6710	19609	41675
500	33	56	93	200	355	575	658	1221	2200	3544	4064	7560	22047	46967
600	36	62	102	219	397	635	730	1349	2430	3936	4408	8269	24334	51739
700	38	69	111	238	427	688	801	1467	2646	4253	4772	9025	26413	56228
800	41	73	120	257	464	737	862	1576	2835	4631	5198	9686	28634	60480
900	43	77	127	272	491	783	919	1686	3013	4938	5576	10348	30335	64260
1000	45	82	134	291	522	828	972	1788	3187	5198	5906	11009	32036	67946
1250	52	93	149	333	586	937	1111	2015	3595	5826	6804	12521	36052	76592

## Pressure Drop in Rubber Hoses - Air

Pressure Drop of Air Through Rubber Hose								
Size (mm)	Cu/m of Free Air							
	0.5	1.0	1.25	1.5	2.0	2.75	3.5	4.25
12.5	249	855	1325	-	-	-	-	-
19	-	215	350	505	895	1725	2745	-
25	-	-	-	-	250	465	755	1100
32	-	-	-	-	80	100	175	285
38	-	-	-	-	-	45	75	135

Pressure Drop of Air Through Rubber Hose												
Size (mm)	Cu/m of Free Air											
	15	20	30	40	50	60	70	80	90	100	125	150
50	385	680	1530	2690	4230	-	-	-	-	-	-	-
64	160	270	565	1020	1630	2350	3170	4185	5270	-	-	-
76	-	-	215	330	520	745	1020	1335	1675	2035	3190	4590

## Pressure Drop in Layflat Hoses

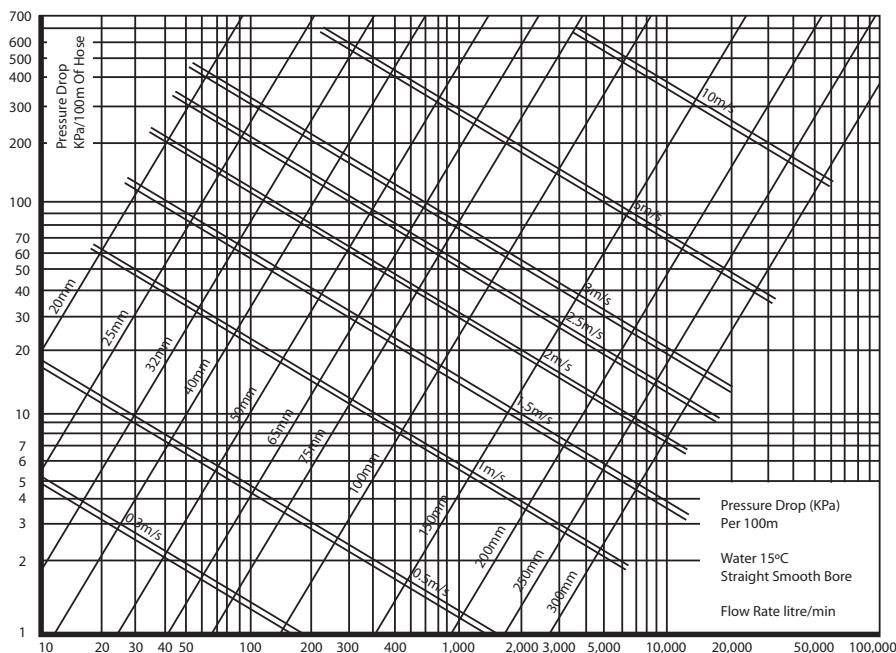

## Chemical Resistance Chart for Rubber Hose

### Key to Chemical Guide

**EX** - Recommended; little or no effect on tube compound; suitable for continuous service

**G** - Recommended; minor effect on tube compound; may be suitable for continuous service; suitable for intermittent service

**C** - Questionable; moderate to severe effect on tube; may be suitable for limited applications

**X** - Not recommended

**I** - No data available, but not expected to perform better than rated compounds

Chemical	EPDM	Hypalon	Natural	Nitrile	Chloroprene	SBR	FKM	Cross Linked Polyethylene	CPE
Acetaldehyde 50%	G	C	G	X	C	C	X	EX	I
Acetic Acid-Glacial	G	C	G	C	X	G	C	EX	EX
Acetic Acid 30%	G	G	G	G	EX	G	G	EX	EX
Acetic Anhydride	C	EX	G	C	G	G	X	EX	EX
Acetone	G	G	C	X	C	C	X	EX	EX
Acetyl Chloride	X	X	X	X	X	X	EX	G	EX
Acetylene	G	G	G	EX	G	G	EX	EX	I
Adipic Acid	G	I	EX	EX	EX	EX	I	I	I
Aluminium Acetate	G	EX	EX	G	G	G	X	EX	EX
Aluminium Chloride	G	EX	EX	EX	EX	EX	EX	EX	EX
Aluminium Fluoride	G	EX	G	EX	EX	EX	EX	EX	I
Aluminium Nitrate	G	EX	EX	EX	EX	EX	EX	EX	EX
Aluminium Sulfate	G	EX	EX	EX	EX	EX	EX	EX	EX
Ammonia Anhydrous	G	G	X	G	EX	X	X	EX	EX
Ammonia Gas (cold)	G	EX	EX	EX	EX	EX	EX	X	EXI
Ammonia Gas (hot)	C	G	X	X	G	X	X	EX	I
Ammonium Carbonate	G	I	EX	X	EX	EX	I	I	EX
Ammonium Chloride	G	EX	EX	EX	EX	EX	EX	EX	EX
Ammonium Hydroxide	G	EX	X	X	EX	X	G	EX	EX
Ammonium Nitrate	G	EX	C	EX	EX	G	I	EX	I
Ammonium Nitrite	G	EX	EX	EX	EX	EX	I	EX	I
Ammonium Phosphate	G	EX	EX	EX	EX	EX	I	EX	EX
Ammonium Sulfate	G	EX	EX	EX	EX	EX	X	EX	EX
Amyl Acetate	X	X	X	X	X	X	X	EX	C
Amyl Alcohol	G	EX	G	G	G	G	G	EX	EX
Aniline	G	C	X	X	X	X	C	EX	G
Aniline Dynes	G	G	G	X	G	G	G	EX	G
Aniline Hydrochloride	C	X	G	G	X	X	G	EX	I
Animal Fats	C	G	X	EX	G	X	EX	EX	EX
Aqua Regia	X	EX	X	X	X	X	G	X	G
Arsenic Acid	G	EX	G	EX	EX	EX	EX	EX	EX
Arsenic Trichloride	X	I	X	EX	EX	I	I	X	I
Asphalt	I	G	X	G	G	X	EX	X	I
Barium Chloride	G	EX	EX	EX	EX	EX	EX	EX	EX
Barium Sulfate	G	EX	EX	EX	EX	EX	EX	EX	EX
Barium Sulphide	G	EX	EX	EX	EX	G	EX	EX	EX
Beer	G	EX	EX	EX	EX	EX	EX	I	EX
Benzene	X	X	X	X	X	X	EX	EX	X
Benzyl Alcohol	G	G	X	X	G	X	EX	EX	I
Benzyl Benzoate	C	X	X	X	X	X	X	EX	I
Benzyl Chloride	X	X	X	X	X	X	EX	EX	X
Benzoic Acid	X	X	X	C	X	X	EX	EX	EX
Bordeaux Mixture	G	EX	G	G	G	G	EX	EX	I
Boric Acid	G	EX	EX	EX	EX	EX	EX	EX	EX
Brine	G	EX	EX	EX	EX	EX	EX	EX	EX
Bromine - Anhydrous	X	X	X	X	X	X	EX	X	I
Bromine Trifluoride	X	X	X	X	X	X	X	X	I
Bromine Water	G	EX	X	X	X	X	EX	X	I
Bromotoluene	X	X	X	X	X	X	EX	C	X
Bunker Oil	X	X	X	EX	X	X	EX	EX	I

## Chemical Resistance Chart for Rubber Hose

Chemical	EPDM	Hypalon	Natural	Nitrile	Chloroprene	SBR	FKM	Cross Linked Polyethylene	CPE
Butane	X	G	X	EX	EX	X	EX	EX	G
Butadiene	X	C	X	X	X	X	EX	EX	I
Butter	G	G	X	EX	G	X	EX	EX	G
Butyl Acetate	X	X	X	X	X	X	X	EX	G
Butyl Alcohol	C	EX	EX	EX	EX	EX	EX	EX	EX
Butyl Amine	G	X	X	C	X	X	X	I	G
Butyl Benzoate	C	X	C	X	X	G	EX	EX	I
Butyl Cellosolve	G	G	X	C	C	X	X	EX	EX
Butyl Stearate	X	X	X	G	X	X	EX	EX	G
Butyraldehyde	C	X	X	X	C	X	X	EX	G
Calcium Acetate	G	G	EX	G	G	X	X	EX	EX
Calcium Bisulfite	X	EX	X	X	EX	X	EX	EX	EX
Calcium Chloride	G	EX	EX	EX	EX	EX	EX	EX	EX
Calcium Hydroxide	G	EX	EX	EX	EX	EX	EX	EX	EX
Calcium Hypochlorite	G	EX	C	G	C	C	EX	C	EX
Calcium Nitrate		EX	EX	EX	EX	EX	EX	EX	EX
Calcium Sulfide	G	EX	G	EX	EX	G	EX	EX	EX
Carbitol	C	G	G	G	G	G	G	EX	EX
Carbonic Acid (phenol)	C	X	X	X	C	X	EX	EX	EX
Carbon Bisulfide	X	X	X	C	X	X	EX	I	C
Carbon Dioxide	C	G	G	EX	G	G	EX	EX	I
Carbonic Acid	G	EX	EX	G	EX	G	EX	EX	EX
Carbon Monoxide	G	G	G	EX	G	G	EX	EX	I
Carbon Tetrachloride	X	X	X	C	X	X	EX	EX	X
Castor Oil	C	G	EX	EX	EX	EX	EX	EX	EX
Cellosolve	C	X	X	X	X	X	C	EX	I
Cellosolve Acetate	C	X	X	X	X	X	X	EX	I
Chlorine (dry)	X	G	X	X	C	X	EX	C	I
Chlorine (wet)	X	C	X	X	C	X	EX	C	I
Chlorine Dioxide	X	C	X	X	X	X	EX	C	I
Chloroacetone	G	C	X	X	C	X	X	EX	X
Chloroacetic Acid	G	EX	X	X	X	X	X	EX	I
Chlorobenzene	X	X	X	X	X	X	EX	EX	X
Chlorobutadiene	X	X	X	X	X	X	EX	EX	I
Chloroform	X	X	X	X	X	X	EX	G	X
Chlorotoluene	X	X	X	X	X	X	EX	G	X
Chrome Plating Solutions	C	X	X	X	X	X	EX	I	I
Chromic Acid	G	G	X	X	C	X	EX	EX	EX
Citric Acid	G	EX	EX	EX	EX	EX	EX	EX	I
Cobalt	G	EX	EX	EX	EX	EX	EX	EX	I
Coconut Oil	X	C	X	EX	G	X	EX	EX	I
Cod Liver Oil	G	G	X	EX	G	X	EX	EX	I
Coke Oven Gas	X	C	X	X	X	X	EX	EX	I
Copper Acetate	G	G	EX	G	G	X	X	EX	I
Copper Chloride	G	G	EX	EX	G	EX	EX	EX	G
Copper Cyanide	G	EX	EX	EX	EX	EX	EX	EX	I
Copper Sulfate	G	EX	G	EX	EX	G	EX	EX	EX
Corn Oil	X	G	X	EX	C	X	EX	EX	G
Cottonseed Oil	C	G	X	EX	G	X	EX	EX	G
Creosote (coal tar)	X	X	X	EX	G	X	EX	EX	I
Cresol	X	X	X	X	C	X	EX	EX	EX
Cresylic Acid	X	X	X	X	C	X	EX	EX	I
Cumene	X	X	X	X	X	X	EX	EX	C
Cyclohexane	X	X	X	EX	C	X	EX	EX	EX
Cyclohexanol	X	G	X	C	EX	X	EX	EX	EX
Cyclohexanone	G	X	X	X	X	X	X	EX	G
P-Cymene	X	X	X	X	X	X	EX	EX	X
Decalin	X	X	X	X	X	X	EX	EX	X
Denatured Alcohol	G	EX	EX	EX	EX	EX	EX	EX	EX
Detergent Solution (non-hydrocarbon)	G	G	G	EX	G	G	EX	EX	G
Diacetone	G	X	X	X	X	X	X	EX	I



## Chemical Resistance Chart for Rubber Hose

Chemical	EPDM	Hypalon	Natural	Nitrile	Chloroprene	SBR	FKM	Cross Linked Polyethylene	CPE
Diacetone Alcohol	G	G	X	X	G	X	X	EX	EX
Dibenzyl Ether	C	X	X	X	C	X	X	EX	C
Dibutyl Amine	G	X	X	X	X	X	X	EX	EX
Dibutyl Ether	X	X	X	X	C	X	C	EX	EX
Dibutyl Phthalate	C	X	X	X	X	X	C	EX	C
Dibutyl Sebecate	C	X	X	X	X	X	G	EX	G
Dichlorobenzene	X	X	X	X	X	X	EX	EX	X
Diesel Oil	X	C	X	EX	C	X	EX	EX	I
Diethylamine	G	C	G	G	G	G	X	EX	G
Diethylamine Benzene	X	X	X	X	X	X	EX	EX	X
Diethyl Ether	X	C	X	X	C	X	X	EX	EX
Diethylene Glycol	G	EX	EX	EX	EX	EX	EX	EX	EX
Diethyl Sebecate	C	G	X	G	X	X	G	EX	G
Diisobutylene	G	X	X	G	X	X	EX	EX	I
Diisopropyl Benzene	X	X	X	X	X	X	EX	EX	I
Diisopropyl Ketone	G	X	X	X	X	X	X	EX	I
Dimethyl Formamide	G	X	X	G	C	X	X	EX	I
Dimethyl Phthalate	G	X	X	X	X	X	G	EX	EX
Dinitrotoluene	X	X	X	X	X	X	EX	EX	X
Diocetyl Phthalate	C	X	X	C	X	X	G	EX	C
Diocetyl Sebecate	C	X	X	X	X	X	G	EX	X
Dipentene	X	X	X	G	X	X	EX	EX	G
Piphenyl (phenylbenzene)	X	X	X	X	X	X	EX	EX	I
Dowtherm Oil	X	X	X	X	X	X	EX	EX	C
Dry Cleaning Fluids	X	X	X	C	X	X	EX	I	I
Ethane	X	G	X	EX	G	X	EX	EX	I
Ethanolamine	G	C	G	G	G	G	X	EX	EX
Ethyl Acetate	G	X	X	X	C	X	X	EX	G
Ethyl Acetoacetate	G	X	C	X	C	C	X	EX	EX
Ethyl Alcohol	G	EX	EX	EX	EX	EX	C	EX	EX
Ethyl Benzene	X	X	X	X	X	X	EX	EX	X
Ethyl Benzoate	G	X	EX	X	X	EX	EX	G	X
Ethyl Cellulose	C	G	G	G	G	G	X	EX	I
Ethyl Chloride	X	X	X	EX	X	X	EX	EX	I
Ethyl Ether	X	X	X	C	C	X	X	EX	EX
Ethyl Formate	C	G	X	X	G	X	EX	EX	EX
Ethyl Pentochloro-benzene	X	X	X	X	X	X	EX	X	X
Ethyl Silicate	G	G	G	EX	EX	G	EX	EX	EX
Ethylene	C	-	C	EX	C	C	EX	I	I
Ethylene Chloride	X	X	X	X	X	X	EX	EX	I
Ethylene Chlorohydrin	C	G	G	X	G	G	EX	EX	I
Ethylene Diamine	G	G	EX	EX	EX	G	X	EX	G
Ethylene Dichloride	X	X	X	X	X	X	EX	EX	C
Ethylene Glycol	G	EX	EX	EX	EX	EX	EX	EX	EX
Ethylene Trichloride	X	X	X	X	X	X	EX	EX	I
Ferric Chloride	G	EX	EX	EX	EX	EX	EX	EX	EX
Ferric Nitrate	G	EX	EX	EX	EX	EX	EX	EX	EX
Ferric Sulfate	G	EX	EX	EX	EX	EX	EX	EX	EX
Fish Oil	X	I	X	EX	X	X	EX	EX	I
Fluoroboric Acid	G	EX	EX	EX	EX	EX	I	EX	EX
Fluorobenzene	X	I	X	X	X	X	EX	EX	I
Fluorolube	G	EX	G	EX	G	C	G	I	I
Fluosilic Acid	C	EX	G	EX	G	C	EX	G	EX
Formaldehyde	G	EX	G	C	G	G	X	EX	EX
Formic Acid	G	X	G	G	EX	EX	C	G	EX
Freon 12	C	EX	G	EX	EX	EX	G	EX	EX
Freon 13	EX	EX	EX	EX	EX	EX	EX	EX	EX
Freon 21	X	X	X	EX	X	X	X	EX	X
Freon 22	G	EX	G	EX	EX	EX	X	EX	EX
Freon 114	G	EX	EX	EX	EX	EX	G	EX	I
Fuel Oil	X	G	X	EX	G	X	EX	EX	EX
Furtural	G	C	X	X	C	X	X	EX	EX
Gallic Acid	G	G	EX	G	G	G	EX	EX	I

### Chemical Resistance Chart for Rubber Hose

Chemical	EPDM	Hypalon	Natural	Nitrile	Chloroprene	SBR	FKM	Cross Linked Polyethylene	CPE
Gasoline	X	C	X	EX	C	X	EX	EX	I
Gelatin	G	EX	EX	EX	EX	EX	EX	EX	I
Glucose	G	EX	EX	EX	EX	EX	EX	EX	I
Glue	G	EX	G	EX	EX	G	EX	EX	EX
Glycerine	G	EX	EX	EX	EX	EX	EX	EX	EX
Glycols	G	EX	EX	EX	EX	EX	EX	EX	I
Green Sulfate liquor	G	G	G	G	G	G	EX	EX	G
Hexane	X	G	X	EX	G	X	EX	G	G
Helix Alcohol	X	G	G	EX	G	G	EX	EX	EX
Hydraulic Alcohol	X	G	X	EX	G	X	EX	EX	EX
Hydrobromic Acid	G	EX	EX	X	X	X	EX	EX	EX
Hydrobromic Acid (hot 37%)	X	X	X	X	X	X	G	EX	I
Hydrochloric Acid	G	EX	G	C	G	G	EX	EX	EX
Hydrocyanic Acid	G	EX	G	G	G	G	EX	C	I
Hydrofluoric Acid (conc. hot)	G	C	X	X	X	X	C	EX	I
Hydrofluoric Acid (conc. cold)	G	EX	X	X	X	X	EX	EX	EX
Hydrofluoric Acid (anhydrous)	G	EX	X	X	X	X	X	EX	I
Hydrofluosilic Acid	C	EX	G	EX	G	C	EX	I	EX
Hydrogen Gas	G	EX	G	EX	EX	EX	EX	EX	EX
Iodine	X	EX	X	X	X	X	X	EX	EX
Isobutyl Alcohol	G	EX	EX	G	EX	G	EX	EX	EX
Isoctane	X	G	X	EX	G	X	EX	EX	G
Isopropyl Acetate	C	X	X	X	X	X	X	EX	I
Isopropyl Alcohol	G	EX	EX	G	G	G	EX	EX	EX
Isopropyl Chloride	X	X	X	X	X	X	EX	EX	I
Isopropyl Ether	X	C	X	G	C	X	X	EX	I
Kerosene	X	C	X	EX	G	X	EX	EX	EX
Lactic Acid (cold)	G	EX	EX	EX	EX	EX	EX	EX	I
Lactic Acid (hot)	G	EX	X	X	X	X	EX	EX	I
Lard	C	X	X	EX	G	X	EX	EX	EX
Lavender Oil	X	X	X	G	X	X	EX	G	I
Lead Acetate	G	X	EX	G	EX	X	X	EX	EX
Lead Nitrate	G	EX	EX	EX	EX	I	EX	EX	EX
Lead Sulfamate	G	EX	G	G	EX	G	EX	EX	I
Linseed Oil	X	G	X	EX	G	X	EX	EX	EX
Liquefied Petroleum Gas	X	G	X	EX	G	X	EX	EX	G
Lubricating Oils	X	G	X	EX	G	X	EX	EX	EX
Lye	G	EX	G	G	G	G	G	I	EX
Magnesium Chl	G	EX	EX	EX	EX	EX	EX	EX	EX
Magnesium Hydroxide	G	EX	G	G	EX	G	EX	EX	EX
Magnesium Sulfate	G	EX	G	EX	EX	G	EX	EX	EX
Maleic Acid	G	X	C	X	C	C	EX	G	I
Maleic Anhydride	C	EX	C	X	C	C	X	I	I
Malic Acid	G	G	C	EX	C	C	EX	I	I
Mercury	G	EX	EX	EX	EX	EX	EX	EX	EX
Mesityl Oxide	C	X	X	X	X	X	X	EX	G
Methane	X	G	X	EX	G	X	G	EX	G
Methyl Acetate	G	X	C	X	G	C	X	EX	EX
Methyl Alcohol	G	EX	EX	EX	EX	EX	X	EX	EX
Methyl Bromide	C	X	X	G	X	X	EX	I	I
Methyl Butyl Ketone (propylacetone)	G	X	X	X	X	X	X	EX	I
Methyl Cellosolve	C	G	X	G	G	X	X	EX	EX
Methyl Chloride	X	X	X	X	X	X	EX	G	X
Methyl Ethyl Ketone (MEK)	C	X	X	X	C	X	X	EX	G
Methyl Isobutyl Ketone	C	X	X	X	X	X	X	EX	G
Methyl Oleate	C	X	X	X	X	X	G	EX	I
Milk	G	EX	EX	EX	EX	EX	EX	EX	EX
Mineral Oil	X	G	X	EX	G	X	EX	EX	EX



**Chemical Resistance Chart for Rubber Hose**

Chemical	EPDM	Hypalon	Natural	Nitrile	Chloroprene	SBR	FKM	Cross Linked Polyethylene	CPE
Monochlorobenzen	X	X	X	X	X	X	EX	G	I
Monoethanolamine	G	X	G	X	X	G	X	EX	I
Monomethylether	X	G	X	EX	C	X	EX	I	G
Monovinyl Acetylene	G	G	G	EX	G	G	EX	I	G
Naphtha	X	X	X	G	C	X	EX	EX	EX
Naphthalene	X	X	X	X	X	X	EX	EX	EX
Napthenic Acid	X	X	X	G	X	X	EX	EX	EX
Natural Gas	X	EX	G	EX	EX	G	EX	EX	EX
Nickel Acetate	G	X	EX	G	G	X	X	EX	I
Nickel Choride	G	EX	EX	EX	EX	EX	EX	EX	EX
Nickel Sulfate	G	EX	G	EX	EX	G	EX	EX	EX
Nitric Acid (conc)	X	G	X	X	X	X	C	G	X
Nitric Acid (dilute)	X	EX	X	X	G	X	EX	EX	EX
Nitrobenzene	G	X	X	X	X	X	G	EX	C
Nitroethane	C	G	G	X	C	G	X	EX	EX
Nitrogen	G	EX	EX	EX	EX	EX	EX	EX	EX
Octachlorofuluene	X	X	X	X	X	X	EX	I	X
Octyl Alcohol	X	G	G	G	EX	G	EX	EX	EX
Oleic Acid	X	C	X	C	C	X	G	EX	EX
Oleum	G	G	X	G	C	X	EX	I	I
Olive Oil	C	G	X	EX	G	X	EX	EX	G
O-Dichlorobenzene	X	X	X	X	X	-	EX	I	X
Oxalic Acid	G	G	G	G	G	G	EX	EX	EX
Oxygen Cold	G	EX	G	G	EX	G	EX	EX	EX
Ozone	G	EX	X	X	C	X	EX	EX	EX
Palmitric Acid	C	C	G	EX	G	G	EX	G	EX
Peanut Oil	X	G	X	EX	C	X	EX	EX	EX
Perchloric Acid	C	G	X	X	G	X	EX	EX	I
Perchloroethylene	X	X	X	G	X	X	EX	EX	X
Petroleum	X	G	X	EX	G	X	EX	EX	EX
Phenol (carbolic Acid)	G	G	X	X	C	I	EX	EX	EX
Phenylbenzene	X	X	X	X	X	X	EX	I	X
Phenyl Hydrazine	C	X	EX	X	X	G	EX	EX	X
Phorone	X	X	X	X	X	X	X	EX	I
Phosphoric Acid 20%	G	EX	G	G	G	G	EX	EX	EX
Phosphoric Acid 80%	G	G	C	X	G	C	EX	EX	EX
Phosphorus Trichloride	G	X	X	X	X	X	EX	I	X
Picric Acid	G	G	G	G	EX	G	EX	EX	G
Pine Oil	X	X	X	EX	X	X	EX	EX	EX
Polyvinyl Acetate Emulsion	G	G	G	I	G	X	EX	I	I
Potassium Acetate	G	EX	EX	G	G	X	X	EX	EX
Potassium Chloride	G	EX	EX	EX	EX	EX	EX	EX	EX
Potassium Cupro Cyanide	EX	EX	EX	EX	EX	EX	EX	EX	EX
Potassium Cyanide	G	EX	EX	EX	EX	EX	EX	EX	EX
Potassium Dichromate	G	EX	G	EX	EX	G	EX	G	EX
Potassium Hydroxide	G	EX	G	G	G	G	X	EX	EX
Potassium Nitrate	G	EX	EX	EX	EX	EX	EX	EX	EX
Potassium Sulfate	G	G	G	EX	EX	EX	EX	EX	EX
Propane	X	G	X	EX	G	X	EX	EX	G
Propyl Acetate	C	X	X	X	X	X	X	EX	G
Propyl Alcohol	G	EX	EX	EX	EX	EX	EX	EX	EX
Propyl Nitrate	G	G	X	X	X	X	X	EX	G
Propylene	X	X	X	X	X	X	EX	EX	EX
Pyranol (transformer oil)	X	C	X	EX	G	X	EX	EX	EX
Pyridine	G	G	X	X	X	X	X	EX	I
Sal Ammoniac	G	EX	EX	EX	EX	EX	EX	EX	EX
Salicyclic Acid	G	-	EX	G	EX	G	EX	EX	EX
Salt Water	G	EX	EX	EX	EX	EX	EX	EX	EX
Sewerage	G	EX	G	EX	G	G	EX	EX	EX
Silicone Greases	G	EX	EX	EX	EX	EX	EX	EX	EX



### Chemical Resistance Chart for Rubber Hose

Chemical	EPDM	Hypalon	Natural	Nitrile	Chloroprene	SBR	FKM	Cross Linked Polyethylene	CPE
Silicone Oils	G	EX	EX	EX	EX	EX	EX	EX	EX
Silver Nitrate	G	EX	EX	G	EX	EX	EX	EX	EX
Skydrol 500	G	X	X	X	X	X	X	EX	G
Skydrol 7000	G	X	X	X	X	X	G	EX	G
Soap Solutions	G	EX	G	EX	G	EX	EX	EX	EX
Soda Ash	G	EX	EX	EX	EX	EX	EX	EX	EX
Sodium Acetate	G	EX	EX	G	G	X	X	EX	EX
Sodium Bicarbonate	G	EX	EX	EX	EX	EX	EX	EX	EX
Sodium Bisulphate	G	EX	EX	EX	EX	G	EX	EX	EX
Sodium Borate	G	EX	EX	EX	EX	EX	EX	EX	EX
Sodium Chloride	G	EX	EX	EX	EX	EX	EX	EX	EX
Sodium Cyanide	G	EX	EX	EX	EX	EX	EX	EX	EX
Sodium Hydroxide	G	EX	EX	G	EX	EX	G	EX	EX
Sodium Hypochlorite	C	EX	X	G	EX	X	EX	G	EX
Sodium Metaphosphate	G	G	EX	EX	G	EX	EX	EX	EX
Sodium Nitrate	G	EX	G	G	G	EX	I	EX	EX
Sodium Perborate	G	G	G	G	G	G	EX	EX	I
Sodium Peroxide	G	G	G	G	G	G	EX	EX	G
Sodium Phosphate	G	EX	EX	EX	G	EX	EX	EX	EX
Sodium Silicate	G	EX	EX	EX	EX	EX	EX	EX	EX
Sodium Sulfate	G	EX	G	EX	EX	G	EX	EX	EX
Sodium Thiosulfate	G	EX	G	G	EX	G	EX	EX	EX
Soybean Oil	X	C	X	EX	G	X	EX	EX	I
Stannic Chloride	G	EX	EX	EX	G	EX	EX	EX	EX
Steam	G	X	X	X	C	X	X	X	X
Stearic Acid	G	G	G	G	G	G	I	EX	EX
Styrene	X	X	X	X	X	X	G	G	C
Sucrose Solution	G	G	EX	EX	G	EX	EX	EX	EX
Sulfur	G	EX	X	X	EX	X	EX	EX	I
Sulfur Chloride	X	G	X	C	C	X	EX	EX	I
Sulfur Dioxide	G	G	G	X	X	G	EX	EX	I
Sulfuric Trioxide	C	X	G	X	X	G	EX	G	X
Sulfuric Acid 10%	G	EX	C	C	G	C	EX	EX	EX
Sulfuric Acid 10%-75%	G	C	X	X	X	X	EX	EX	X
Sulfurous Acid	G	EX	G	G	G	G	EX	EX	EX
Tannic Acid	G	EX	EX	EX	EX	EX	EX	EX	EX
Tar Bituminous	X	X	X	G	C	X	EX	I	I
Tartaric Acid	C	EX	C	EX	G	X	EX	EX	EX
Terpineol	X	X	X	G	X	X	EX	G	EX
Tertiary Butyl Alcohol	G	G	G	G	G	G	EX	EX	G
Tetrachloroethylene	X	X	X	X	X	X	EX	EX	C
Tetraethyl Lead	X	X	X	G	G	X	EX	I	I
Toluene	X	X	X	X	X	X	EX	EX	C
Transformer Oil	X	C	X	EX	G	X	EX	EX	EX
Transmission Fluid	X	G	X	EX	G	X	EX	EX	EX
Trichloroethane	X	X	X	X	X	X	EX	EX	C
Trichloroacetic Acid	C	X	C	G	X	G	C	EX	I
Trichloroethylene	X	X	X	X	X	X	EX	EX	X
Tricresyl Phosphate	X	X	X	X	X	C	EX	EX	EX
Triethanol Amine	G	G	G	G	EX	G	X	EX	EX
Trinitrotoluene	X	G	X	X	G	X	EX	EX	G
Turbine Oil	X	X	X	G	X	X	EX	EX	I
Turpentine	X	X	X	EX	X	X	EX	EX	I
Vegetable Oils	X	G	X	EX	C	X	EX	EX	EX
Vinegar	G	EX	G	G	G	G	EX	EX	EX
Vinyl Chloride	X	X	X	X	X	X	EX	EX	C
Water	G	EX	EX	EX	EX	EX	EX	EX	EX
Whiskey, Wines	G	EX	EX	EX	EX	EX	EX	EX	EX
White Oil	X	X	X	EX	G	X	EX	EX	EX
Wood Oil	X	C	X	EX	G	X	EX	EX	EX
Xylene	X	X	X	X	X	X	EX	EX	EX
Zinc Chloride	G	EX	EX	EX	EX	EX	EX	EX	EX
Zinc Sulfate	G	EX	G	EX	EX	G	EX	EX	EX



## PVC Hose Chemical Resistance Specifications

Plasticisers are incorporated in PVC compounds so as to confer flexibility and softness. Plasticised compounds can cover a very wide range of flexibility and softness and will also differ in other respects, e.g. tensile strength and resilience, according to the type and/or amount of plasticiser/s used. For example, the type of plasticiser used will affect chemical resistance, but in this note it has been assumed that a commonly used, fairly resistant plasticiser such as dioctyl phthalate (DOP) would be present.

The amount of plasticiser incorporated will also effect the chemical resistance, an increase in plasticiser content leading to a deterioration in chemical resistance because the plasticiser is less resistant to attack than is the PVC. The chemical resistance to be expected from plasticised PVC when DOP is used as the plasticiser is summarised in the following paragraphs.

### Acids and Alkalis

Dilute acids and alkalis have little effect at room temperature, but at elevated temperatures some hydrolysis and extraction of plasticiser may occur. Concentrated acids and alkalis hydrolyse plasticisers slowly in the cold and more rapidly when heated. The main effect of organic liquids on plasticised PVC is to extract the plasticiser and this results in some hardening, particularly when the PVC is removed from contact with the liquid. The compound may become rigid and less tough.

Most organic solvents will extract plasticiser and give rise to these effects, but with aromatic and chlorinated hydrocarbons, aliphatic and cyclic ethers, this plasticiser extraction is accompanied by a softening of the PVC and the overall effect is difficult to predict. With certain solvents too, plasticiser extracted is replaced by the solvent so that the compound remains flexible provided it remains in contact with that liquid. On allowing the solvent to evaporate the material will stiffen and will not soften on re-immersion.

The undesirable effects previously mentioned which can occur with PVC compounds containing a monomeric ester type plasticiser, such as DOP, can be prevented or reduced by the use instead of a polymeric type of plasticiser which affords a higher resistance to extraction. Such plasticisers include polypropylene adipate (PPA) and polypropylene sebacate (PPS), the former being of value in contact with oils and fuels and the latter showing a high degree of resistance to soap and detergent solutions.

The symbols used to denote performance are as follows:

- 1 - Satisfactory.
- 2 - Recommended for the service and conditions for oil hoses.
- 3 - The material may be considered for use when alternative materials are unsatisfactory and when limited life is acceptable.
- 4 - When PVC is to be used with such chemicals, full-scale trials under realistic conditions are particularly necessary.
- 5 - Unsatisfactory.

For materials which have been rated as having Limited Life or Unsatisfactory, the material should only be considered for use when alternative materials are unsatisfactory and where limited life is accepted. When PVC is to be used with such chemicals, full-scale trials under realistic conditions are particularly necessary.

It may be safely assumed that chemical resistance decreases with both increasing temperature and with increasing concentration of reagent, and that the reverse is also true. No valid assumptions can be made, however, if the temperature and concentration move in compensating directions.

The following chemical resistance chart is not intended to be complete. Chemicals missing from this chart does not indicate unsuitability.

Refer to pages 337-338 for chemical resistance chart.

## Temperature Chart for Layflat Hoses

### TEMPERATURE CHART FOR LAYFLAT HOSES

PVC is a thermoplastic material and therefore, burst pressure varies with temperature.

The graph shows variation in burst temperature with temperature for the different types of Layflat hoses.

- High Pressure Brick Red, Green Dewatering
- Low Pressure Blue

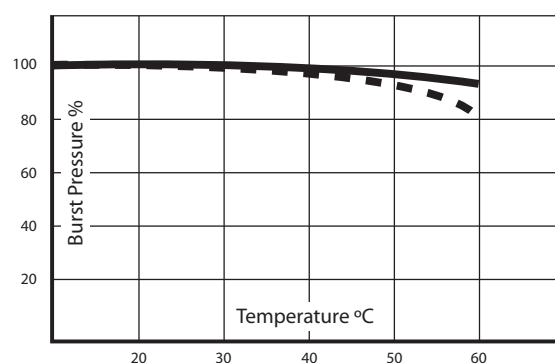

## Chemical Resistance Chart For PVC Hose

The symbols used to denote performance are as follows

1 - Satisfactory

2 - Recommended for the service and conditions for oil hoses

3 - The material may be considered for use when alternative materials are unsatisfactory and when limited life is acceptable

4 - When PVC is to be used with such chemicals, full-scale trials under realistic conditions are particularly necessary

5 - Unsatisfactory

Chemical	Concentration	Conditions	
		20°C	60°C
Acetic Acid	10%	1	3
	60%	1	3
	Glacial	5	5
Acetic anhydride		5	5
Acetone	Traces	5	5
	100%	5	5
Adipic acid		4	4
Alcohol allyl		5	5
Alcohol ethyl	40% w/w water	1	4
	100%	1	4
Alcohol isopropyl		1	4
Alcohol methyl	6% aq. solution	1	1
	100%	3	4
Allyl chloride		5	5
Aluminium salts		1	1
Ammonia	s.g. = 0.88 aq. solution	1	5
	Dry gas	4	4
	Liquid	4	4
Ammonium hydroxide		1	4
Ammonium salts		1	1
Ammonium sulfide		1	5
Aniline		5	5
Animal oil		1	4
Barium salts		1	1
Beer		1	4
Benzaldehyde	Traces	5	5
	100%	5	5
Benzene		5	5
Borax		1	4
Brine		1	1
Bromine	Gas, traces	5	5
	100% dry gas	5	5
	Liquid	5	5
Butane		4	4
Butanol		1	4
Butyl acetate		5	5
Butyric acid	20% aq. solution	1	4
	Concentrate	5	5
Calcium hydroxide		1	4
Calcium hypochlorite		1	4
Calcium salts		1	1
Carbon dioxide		1	1
Carbon disulphide		5	5
Carbon monoxide		1	1
Carbon tetrachloride		5	5

Chemical	Concentration	Conditions	
		20°C	60°C
Casein		1	1
Chlorine water	Saturated solution	3	5
Chlorobenzene		5	5
Chlorine	10% (dry gas)	4	4
	100% (dry gas)	4	4
	10% (most gas)	4	4
Chloroform		5	5
Chlorosulfonic acid		5	5
Chromic acid	Plating solution	5	5
	Conc	4	4
Citric acid		1	4
Copper salts		1	1
Cucloexanol		5	5
Cyclohexanone		5	5
Detergents, synthetic	All concentrates	1	4
Developers, photographic		1	1
Dextrose		1	1
Dichlorethylene		5	5
Dichlorobenzene		5	5
Diesel oil		2	2
Diethyl ether		5	5
Dimethylamine		4	4
Emulsifiers	All concentrates	1	1
Emulsions, photographic		1	1
Ether		5	5
Ethyl acetate		5	5
Ethylene dichloride		5	5
Ethylene glycol		1	4
Fatty acids		4	4
Ferric salts		1	1
Fixing solution, photographic		1	1
Fluorine		5	5
Formaldehyde	40% w/w in water	1	4
	40%	4	4
Formic acid	50%	3	5
	100%	5	5
Glucose		1	1
Glycerine		1	4
Grape sugar		1	1
Hydrochloric acid	10% aq. solution	1	1
	22%	1	1
	Conc.	1	3
	4% aq. solution	1	

## Chemical Resistance Chart For PVC Hose

Chemical	Concentration	Conditions	
		20°C	60°C
Hydrofluoric acid	40% aq. solution	1	4
	60% aq. solution	5	5
	Concentrate	5	5
Hydrogen		1	1
Hydrogen bromide anhydrous		1	4
Hydrogen chloride anhydrous		1	4
Hydrogen fluoride		1	4
Hydrogen peroxide	3% (10 vol)	1	4
	12% (40 vol)	1	4
	30% (100 vol)	1	4
	90% and above	1	4
Hydrogen sulphite		1	4
Iodine	Solution in potassium	4	4
	Iodide	5	5
Lacquer solvents		3	5
Lactic acid	10%	1	4
	100%	5	5
Lauric acid		1	4
Lauryl alcohol		1	1
Leads salts		1	1
Magnesium salts		1	1
Manganese sulphate	Concentrate solution	1	1
Mercuric chloride		5	5
Methyl chloride		5	5
Methyl ethyl ketone		5	5
Methylene chloride		5	5
Milk		1	4
Mineral oils		2	2
Mixed acids (sulphuric/nitric)	Various proportions	4	5
Molasses		1	1
Naphtha		5	5
Naphthalene		5	5
Nickel salts		1	1
Nitric acid	10%	1	4
	25%	1	4
	50%	1	3
	70%	3	5
	95%	5	5
Nitrobenzene		5	5
Nitrogen fertilizers		1	4
Nitrous fumes	Moist	4	5
Oleic acid		1	4
Oxalic acid		1	4
Oxygen		1	1
Ozone		1	4
Palmitic acid		1	4
Paraffin		3	4
Petrol		2	2
Petrol benzene mixture	80:20	5	5
Phenol		4	5
Phosphoric acid	20% aq. solution	1	1
	30% aq. solution	1	1

Chemical	Concentration	Conditions	
		20°C	60°C
Phosphoric developers		1	1
Photographic emulsions		1	1
Photo fixing solution		1	1
Picric acid	1% w/w in water	1	1
	10% w/w in alcohol	1	4
Potassium hydroxide	1% aq. solution	1	1
	10% aq solution	1	1
	conc. aq. solution	1	5
Potassium salts		1	1
Propane		2	2
Propylene dichloride		5	5
Salicylic acid		4	4
Sea water		1	1
Soap solution		1	4
Sodium hydroxide	1% aq. solution	1	4
	10% aq. solution	1	3
	40% aq. solution	1	5
	Conc. aq. solution	1	5
Sodium hypochlorite	15% act. cl	1	3
Sodium salts		1	1
Sulphur dioxide	Dry	1	1
	Moist	4	5
	Liquid	4	5
Sulphuric acid	10%	1	1
	45%	1	1
	50%	1	3
	60%	3	3
	98%	5	5
	Fuming	5	5
Sulphurous acid	30%	1	4
Tallow		1	4
Tannic acid		1	4
Tanning extracts		1	4
Tartaric acids		1	4
Tetraethyl lead		1	4
Tetrahydrofuran		5	5
Tetralin		5	5
Toluene		5	5
Transformer oil		2	5
Trichloroethane		5	5
Triethanolamine		1	1
Trichloroethylene		5	5
Triethylamine		4	4
Turpentine		4	4
Urea		1	4
Vegetable oil		1	4
Vinegar		1	4
Vinyl acetate		5	5
Water		1	1
Wetting agents		1	1
Wines and spirits	All concentrates	1	4
Xylene		5	5
Zinc salts		1	1

## Understanding the Forces at Work

In all pressurised hose and piping systems there are invisible forces at work being used to transfer media through the system or to provide energy to equipment to perform the required task.

The same features of a pressurised system that make it useful also make it potentially dangerous. To keep pressurised systems safe it is crucial that the forces are understood and that the equipment being used (i.e. hose, pipe, etc.) is suitable for the application.

Hose assemblies must be designed and built with confidence that they will perform to requirements without chance of failure. To achieve the required level of confidence, the hose must either have a proven history or be tested and certified for use in that application. There is often just too much to risk should something go wrong.

The amount of end force on a hose assembly is determined by multiplying the pressure by the end cross sectional area. This end force is the force that a clamp must resist to prevent the fitting from coming out of the hose. For example, a 1" hose at **100 PSI** exerts 79 pounds (36kg) end force. However a 6" hose installed on the same system operating at **100 PSI** will exert an end force of 2,827 pounds (1,282kg) end force.

The clamp in a hose assembly is attempting to create a frictional force between the hose and fitting greater than the force trying to push the fitting out. A hose clamp is producing both friction and a lock to overcome this end force.

Why then do fittings come out of hoses? Either the end force is greater than the frictional force on a smooth tail fitting, or the material changes shape and "flows" out of the barbs, known as 'cold flow'.

"Cold flow is the distortion, deformation, or dimensional change that takes place in materials under continuous load at temperatures within the acceptable working range."

Simply put, this means the material flows and moves. In relation to hose assemblies, the force applied by the hose clamp combined with the end force caused by pressure will cause the ends of the hose to stretch out resulting in a thinner wall section. The flow on effects this has created is reduced torque on clamp bolts and less clamping force between the clamp, hose, and hose tail.

The effects of cold flow will vary depending on many factors such as materials, temperature, fitting geometry, etc.

When specifying a hose it is most important to ensure that all of the application criteria are explained so that a hose assembly can be specified to suit. Something as seemingly minor as a slightly elevated working temperature can dramatically effect the performance of the hose assembly.

The final consideration needs to be maintenance to your hose assembly. Although your hose assembly has been built to specifications, consideration still needs to be given to cold flow. Bolted hose assemblies must have the torque ratings checked "routinely". Many end users demand to know what "routinely" means and ask the hose supplier to specify requirements. Unfortunately, due to the number of variables at play, "routinely" can not be defined or specified. What must be done is for the end user to seek advice from the supplier on how to best maintain their hose assemblies.

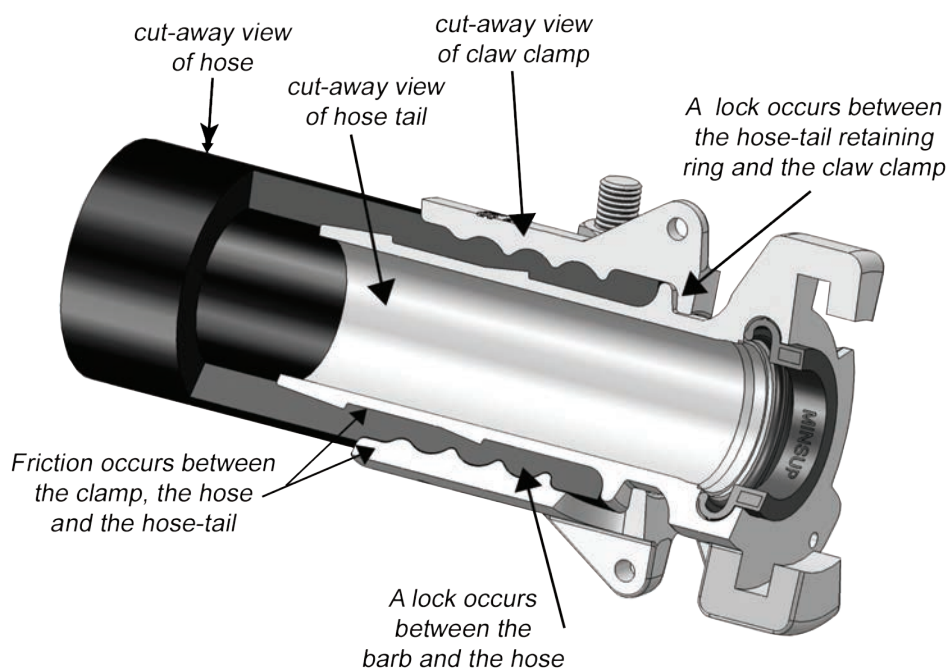

## Force Chart

Hose/Pipe ID		End Pull Force in Kilograms										
inch	mm	25 PSI	50 PSI	75 PSI	100 PSI	150 PSI	200 PSI	250 PSI	300 PSI	500 PSI	1000 PSI	2000 PSI
¼	6	1	1	2	2	3	4	5	7	11	22	44
⅜	10	1	2	4	5	7	10	12	15	25	49	98
½	13	2	4	7	9	13	17	22	26	44	87	175
¾	19	5	10	15	20	29	39	49	59	98	197	393
1	25	9	17	26	35	52	70	87	105	175	349	699
1¼	32	14	27	41	55	82	109	136	164	273	546	1,092
1½	38	20	39	59	79	118	157	197	236	393	786	1,572
2	51	35	70	105	140	210	279	349	419	699	1,397	2,795
2½	64	55	109	164	218	328	437	546	655	1,092	2,184	4,367
3	76	79	157	236	314	472	629	786	943	1,572	3,144	6,289
4	102	140	279	419	559	838	1,118	1,397	1,677	2,795	5,590	11,180
5	127	218	437	655	873	1,310	1,747	2,184	2,620	4,367	8,734	17,468
6	152	314	629	943	1,258	1,887	2,515	3,144	3,773	6,289	12,577	25,154
8	203	559	1,118	1,677	2,236	3,354	4,472	5,590	6,708	11,180	22,359	44,718
10	254	873	1,747	2,620	3,494	5,240	6,987	8,734	10,481	17,468	34,936	69,872
12	305	1,258	2,515	3,773	5,031	7,546	10,062	12,577	15,092	25,154	50,308	100,616

Note: For hose IDs from 2" to 12" the force in kilograms is greater than the PSI.

FORCE is the dynamic power which is exported longitudinally through a hose, towards the ends. To arrive at the number of kilograms of FORCE exerted, you multiply the area of the ID times the working pressure being used.

AREA OF A CIRCLE:  $\pi \times R^2$  (PI [3.1416] x radius squared)

FORCE = AREA x PRESSURE

Force Slide Charts are available on request.

## Corrosion Resistance of Coupling Material

### Ratings

#### Metal:

- 1 Excellent
- 2 Good
- 3 Fair
- X Not Recommended
- Contact Dixon™

#### Non-Metal:

- A Acceptable
- X Not Recommended
- Contact Dixon™

#### Gasket/Seal Material:

- T PTFE
- V FKM
- E EPDM, EPR
- N Neoprene
- B Buna-N

### Caution:

The following data has been compiled from generally available sources and should not be relied upon without consulting and following the specific recommendations of the manufacturer regarding particular coupling materials.

### Note:

Ratings given are based at 21°C (70°F). Chemical compatibility varies greatly with temperature. For applications at temperatures other than 21°C (70°F), contact Dixon™ for recommendations. Gasket/seal materials are not necessarily listed in order of preference. Chemical resistance of a material does not necessarily indicate the suitability of a fitting in a given application due to variables such as improper clamp and coupling application, special hose construction, gasket material, etc.

Special caution should be taken when handling hazardous materials.

Agent	Aluminium	Brass	Bronze	Hastelloy, C-276	Malleable Iron Carbon Steel	Monel	Stainless Steel, 304	Stainless Steel, 316	Nylon	Polypropylene	Seal Material
Acetate Solvents (Crude)	1	X	X	1	1	2	1	1	A	X	T
Acetate Solvents (Pure)	1	1	1	1	1	1	1	1	A	X	T
Acetic Acid (80%)	3	X	X	1	1	1	1	1	X	X	TEVNB
Acetic Acid (50%)	2	X	X	1	1	2	2	1	X	X	TEVNB
Acetic Acid (20%)	2	X	X	1	1	2	2	1	X	X	TEVNB
Acetic Acid (10%)	2	X	2	1	1	2	1	1	X	X	TEVNB
Acetic Anhydride	2	X	2	1	1	2	2	2	X	X	TNB
Acetone	1	2	2	1	1	1	1	1	A	X	TE
Acetylene	1	X	X	2	2	2	1	1	X	X	TEVNB
Alcohols											
Amyl Alcohol	2	2	2	2	2	1	2	2	A	A	TEVNB
Benzyl Alcohol	2	2	2	2	2	1	1	1	X	A	TVB
Butyl Alcohol	1	2	1	2	2	1	1	1	A	A	TEVN
Diacetone Alcohol	1	1	2	1	1	1	2	2	X	A	TE
Ethyl Alcohol	1	2	2	1	1	2	2	2	X	A	TEVNB
Hexyl Alcohol	-	-	-	1	1	-	-	-	A	-	-
Isobutyl Alcohol	-	-	-	-	-	-	-	-	A	-	-
Isopropyl Alcohol	2	2	2	2	2	2	2	2	A	A	TEVNB
Methyl Alcohol (Methanol)	2	2	2	1	1	2	2	2	A	A	TENB
Octyl Alcohol	-	-	-	-	-	-	-	-	A	-	-
Propyl Alcohol	2	2	2	1	1	2	1	1	X	A	TEVNB
Aluminium											
Aluminium Chloride (Aqu.)	X	X	X	1	1	X	X	X	A	A	TEVNB
Aluminium Fluoride (Sat.)	2	-	-	-	-	2	X	2	X	A	TEVNB
Aluminium Nitrate (Sat.)	3	X	-	-	-	-	2	2	A	A	TEVNB
Aluminium Potassium Sulfate (Alum.)	2	2	2	2	2	2	X	2	X	A	TEVNB
Aluminium Sulfate (Sat.)	X	X	2	2	2	2	-	2	A	A	TEVNB
Ammonia											
Ammonia Anhydrous (* not plated)	1	X	X	2	2	1	2	1	A	X	TENB
Ammonia Gas	X	X	X	1	1	X	1	1	A	X	TENB
Ammonia Nitrate	-	-	-	-	-	-	-	-	X	-	-
Ammonium											
Ammonium Bifluoride	-	X	-	2	2	2	-	-	X	A	TEVB

Ratings given are based at 21°C (70°F)



## Corrosion Resistance of Coupling Material

Agent	Aluminium	Brass	Bronze	Hastelloy, C-276	Malleable Iron Carbon Steel	Monel	Stainless Steel, 304	Stainless Steel, 316	Nylon	Polypropylene	Seal Material
Ammonium Carbonate (Sat.)	2	X	X	2	2	2	2	2	A	A	TEVNB
Ammonium Casenate	-	-	-	-	-	-	-	-	A	-	-
Ammonium Chloride (Sat.)	X	X	2	2	2	2	X	X	A	A	TEVNB
Ammonium Hydroxide (Sat.)	2	X	X	2	2	X	2	2	A	A	TEVNB
Ammonium Nitrate	2	X	X	-	-	X	-	-	A	A	TENB
Ammonium Phosphate (10-40%)	X	X	X	-	-	2	1	2	A	A	TEVNB
Ammonium Sulfate (10-40%)	X	X	3	2	2	2	X	2	A	A	TEVNB
Aniline	-	X	2	2	2	2	1	1	X	X	TV
Arsenic Acid	X	X	2	2	2	X	2	2	X	A	TEVNB
Asphalt	-	-	-	-	-	-	-	2	X	X	TV
Barium											
Barium Carbonate (Sat.)	X	2	2	2	2	2	2	2	A	A	TEVNB
Barium Chloride (Sat.)	-	2	2	1	1	2	X	-	A	A	TEVNB
Barium Hydroxide (Sat.)	X	2	X	2	2	1	2	2	A	A	TEVNB
Barium Sulfate	2	2	2	-	-	2	2	2	A	A	TEVNB
Barium Sulfide	X	X	X	-	-	X	2	2	A	A	TEVNB
Beer	1	2	2	1	1	1	1	1	A	A	TEVNB
Benzaldehyde	2	2	2	2	2	2	2	2	X	X	TE
Benzene, Benzol	1	2	2	2	2	2	2	2	A	X	TV
Benzine	-	-	-	-	-	-	-	-	A	X	-
Benzoic Acid	2	2	2	-	-	2	2	2	X	X	TVN
Black Liquor	X	X	X	X	X	2	2	2	X	A	TEVNB
Bleach (12.5% Active Chlorine)	X	-	-	1	1	-	-	X	X	A	TEVN
Borax	X	2	2	1	1	1	1	1	X	A	TEVNB
Boric Acid	1	X	2	1	1	2	-	-	X	A	TEVNB
Brine Acid	-	2	2	1	1	-	-	-	X	A	TEVNB
Bromic acid	X	X	X	-	-	X	-	-	X	A	TEVN
Bromine Liquid	2	-	-	-	-	-	X	X	X	X	TV
Butadiene, Butylene	2	2	2	2	2	1	2	2	X	X	TVNB
Butane	2	2	2	2	2	1	2	2	X	X	TV
Butyl Acetate	1	2	2	2	2	2	2	2	A	X	T
Butyric Acid	2	2	X	1	1	2	2	2	A	A	TV
Calcium											
Calcium Bisulfate	X	-	X	-	X	X	X	2	X	A	T
Calcium Bisulfide	-	-	-	-	-	2	-	2	A	A	TVB
Calcium Bisulfite	X	X	2	2	X	X	-	2	X	A	TVNB
Calcium Bromide	X	G	G	-	X	G	E	X	X	X	T
Calcium Carbonate	X	2	2	2	2	2	1	2	A	A	TEVB
Calcium Chloride (Sat.)	-	2	-	1	2	2	-	-	A	A	TEVNB
Calcium Hydroxide (Sat.)	X	2	X	-	2	2	2	2	A	A	TEVNB
Calcium Hypochlorite (Sat.)	X	X	X	-	X	X	X	2	X	A	TEV
Carbon											
Carbon Bisulfide	1	X	2	2	2	X	2	2	A	X	TV
Carbon Dioxide (Dry)	1	1	2	1	2	1	2	2	A	A	TENB
Carbon Dioxide (Wet)	1	X	-	2	3	-	2	2	X	A	TENB
Carbon Disulfide	1	X	2	2	2	X	2	2	A	X	TV
Carbon Monoxide	1	1	1	1	2	1	1	1	A	A	TEVNB
Carbon Tetrachloride	X	-	1	1	2	1	1	-	A	X	TV

Ratings given are based at 21°C (70°F)



## Corrosion Resistance of Coupling Material

Agent	Aluminium	Brass	Bronze	Hastelloy, C-276	Malleable Iron Carbon Steel	Monel	Stainless Steel, 304	Stainless Steel, 316	Nylon	Polypropylene	Seal Material
Carbonic Acid	1	2	2	1	2	3	2	2	X	A	TEVNB
Castor Oil	2	2	2	1	2	1	2	2	X	A	TEVNB
Caustic Potash	X	-	-	1	X	-	-	2	A	A	TEVNB
Caustic Soda (see Sodium Hydroxide)											
Cellosolves	2	2	2	2	2	2	2	2	X	A	TE
Chlorine (Liquid)	-	-	-	1	2	2	-	3	X	X	TV
Chloroform	-	-	-	2	X	1	-	-	X	X	TV
Chlorosulfonic Acid	-	X	X	1	2	2	X	X	X	X	T
Clorox (Bleach, 5.5% CL)	X	-	-	-	X	-	-	2	X	-	TEVB
Chromic Acid (50%)	2	X	X	2	X	X	3	-	X	X	TVNB
Citric Acid	3	X	X	1	X	2	-	-	X	A	TEVNB
Coke Oven Gas	2	3	3	-	2	2	2	2	X	X	TEVN
Copper											
Copper Chloride	X	X	X	2	X	X	X	X	A	A	TEVNB
Copper Cyanide	X	X	X	1	-	X	2	2	X	-	TEVNB
Copper Sulfate	X	X	X	1	X	X	-	2	A	A	TEVNB
Crylic Acid (Conc.)	2	2	X	-	2	3	2	2	X	X	TEV
Cyclohexane	2	2	2	2	2	1	2	2	A	X	TVB
Detergents	2	2	2	1	2	-	1	2	A	A	TEVNB
Dextrose	2	-	-	2	-	2	-	-	A	A	TEVNB
Diesel Fuels	1	1	1	2	2	-	1	1	A	X	TVB
Diethylamine	2	-	X	-	X	1	2	2	X	A	TN
Disodium Phosphate	-	-	-	-	1	-	-	1	A	A	TEV
Ethers	2	2	2	2	2	2	1	1	A	X	TB
Ethyl											
Ethyl Acetate	-	-	2	2	2	2	2	2	A	X	T
Ethyl Chloride	-	-	2	2	2	2	-	1	A	X	TEVB
Ethylene											
Ethylene Chloride	-	-	-	-	2	2	-	-	A	X	TV
Ethylene Dichloride	-	2	X	2	2	1	2	2	A	X	TV
Ethylene Glycol	1	2	2	1	2	2	2	2	A	X	TEVNB
Ethylene Oxide	1	X	X	1	2	2	2	2	X	X	T
Fatty Acids	1	3	3	1	X	2	-	1	A	A	TVNB
Ferric											
Ferric Chloride	X	X	2	2	X	X	X	X	X	A	TEVNB
Ferric Hydroxide	-	-	-	1	-	2	1	1	A	-	TEVNB
Ferric Nitrate (10-50%)	X	X	X	-	X	X	2	2	X	A	TEVNB
Ferric Sulfate	X	X	X	-	X	2	-	-	X	A	TEVNB
Ferrous											
Ferrous Chloride (Sat.)	X	X	2	2	-	X	X	X	X	A	TEVNB
Ferrous Sulfate	2	2	2	2	X	2	2	-	X	A	TEVNB
Fluboric Acid	X	-	-	1	1	2	-	-	X	A	TEVNB
Formaldehyde (50%)	-	2	2	2	X	2	1	1	X	A	TEN
Formic Acid (Anhyd.)	1	X	2	1	X	2	-	-	X	A	TEVN
Freon											
Freon 11	2	2	2	-	X	1	2	2	X	X	TVNB
Freon 12	2	2	2	1	X	2	2	2	X	X	TVNB
Freon 22	2	2	2	2	X	2	2	2	X	X	TN
Fruit Juices	2	2	3	1	X	1	2	2	A	A	TVNB

Ratings given are based at 21°C (70°F)

## Corrosion Resistance of Coupling Material

Agent	Aluminium	Brass	Bronze	Hastelloy, C-276	Malleable Iron Carbon Steel	Monel	Stainless Steel, 304	Stainless Steel, 316	Nylon	Polypropylene	Seal Material
Fuel Oil	2	2	2	2	2	2	2	2	A	X	TVNB
Furfural	2	2	2	2	2	2	2	2	A	X	TEN
Gasoline											
Refined Gasoline	2	2	2	2	2	2	2	2	A	X	TVNB
Sour Gasoline	X	2	2	2	2	X	2	2	A	X	TVNB
Gelatin	2	2	2	-	X	2	2	2	A	A	TEVNB
Glucose	2	2	2	-	2	2	2	2	A	A	TEVNB
Glue	2	2	2	1	2	2	-	2	-	A	TEVNB
Glycerine	1	1	2	1	2	1	1	1	A	A	TEVNB
Glycols	2	2	2	-	2	2	2	2	A	A	TEVNB
Green Liquor	-	-	-	-	2	-	-	-	-	A	TEVNB
Heptane	2	2	2	1	2	2	2	2	A	X	TVNB
Hexane	2	2	2	1	2	2	1	1	A	X	TVNB
Hydrobromic Acid (50%)	X	X	X	2	X	X	X	X	X	A	TEV
Hydrobromic Acid (20%)	X	X	X	1	X	X	X	X	X	A	TEV
Hydrochloric Acid (20%)	X	X	X	1	X	3	X	X	X	A	TEVNB
Hydrochloric Acid (38%)	X	X	X	1	X	X	X	X	X	A	TEVN
Hydrocyanic Acid	2	X	X	2	2	2	2	2	X	A	TEVN
Hydrofluosilicic Acid (10-50%)	X	2	X	2	X	2	X	2	X	-	TEVNB
Hydrogen											
Hydrogen Peroxide (50%)	-	X	X	2	X	2	-	-	X	A	TEV
Hydrogen Sulfide (Aqu.)	-	-	-	2	-	2	X	2	X	A	TE
Hydrogen Chloride (Dry Gas)	X	2	-	1	2	1	-	-	X	A	TEVN
Hydrogen Gas	1	1	1	1	-	1	1	1	X	A	TEVNB
Hypochlorous Acid	X	X	X	2	X	X	X	X	X	X	TEV
Iodine	1	X	X	-	X	1	X	X	X	A	TEV
Isopropyl Ether	-	2	2	-	-	2	1	2	A	X	T
Jet Fuel (JP4, JP5)	2	1	2	1	2	2	2	2	X	X	TV
Kerosene	2	2	2	2	2	2	2	2	X	X	TVNB
Ketones	2	2	2	1	2	2	2	2	A	X	T
Lactic Acid (25%)	3	2	2	1	X	X	-	-	A	A	TEVN
Lactic Acid (80%)	2	2	X	2	X	-	-	-	A	A	TEVN
Lard Oil	2	-	2	1	3	2	2	2	A	A	TVB
Lead											
Lead Acetate	X	X	X	2	X	2	2	2	X	A	TENB
Lead Chloride	X	-	-	2	-	-	2	2	X	-	TVNB
Lead Sulfate	X	-	-	2	X	2	2	2	X	-	TEVNB
Lime Sulphur	X	X	X	-	X	2	2	2	X	A	TEVN
Linoleic Acid	2	X	3	2	X	2	2	2	X	A	TVB
Linseed Oil	2	2	2	2	2	2	2	2	A	A	TVNB
Lubricants (Oil)	2	1	-	-	2	2	2	2	A	X	TVNB
Magnesium											
Magnesium Carbonate	2	-	-	-	-	2	2	2	X	A	TEVNB
Magnesium Chloride	X	X	2	1	-	-	-	-	X	A	TEVNB
Magnesium Hydroxide	2	2	2	1	2	2	1	1	X	A	TEVNB
Magnesium Nitrate	2	2	2	1	2	2	2	2	X	A	TEVNB
Magnesium Oxide	-	-	-	-	-	-	-	-	X	-	-
Magnesium Sulfate	2	-	2	-	-	1	2	2	X	A	TEVNB
Maleic Acid	-	2	3	2	X	-	-	2	X	A	TEV

Ratings given are based at 21°C (70°F)

## Corrosion Resistance of Coupling Material

Agent	Aluminium	Brass	Bronze	Hastelloy, C-276	Malleable Iron Carbon Steel	Monel	Stainless Steel, 304	Stainless Steel, 316	Nylon	Polypropylene	Seal Material
Mercuric											
Mercuric Chloride	X	X	X	-	X	X	X	-	X	A	TEVB
Mercuric Cyanide	X	X	X	2	X	2	2	2	X	A	TEVB
Mercury	X	X	X	1	2	-	1	1	A	A	TEVNB
Methane	1	1	2	1	2	1	1	1	A	X	TEVNB
Methanol	2	2	2	1	2	2	2	2	A	A	TENB
Methyl											
Methyl Bromide	X	-	-	-	2	-	2	2	X	X	TV
Methyl Ethyl Ketone	2	2	2	2	2	2	2	2	A	X	TE
Methyl Isobutyl Ketone	2	2	2	2	2	2	2	2	A	X	T
Methyl Methacrylate	2	-	-	-	X	-	2	2	X	A	T
Methylene Chloride	-	2	2	X	2	-	-	-	A	X	T
Milk	1	X	X	1	2	X	1	1	A	A	TEVNB
Mineral Oil	2	1	-	-	2	1	1	2	A	A	TVNB
Muriatic Acid	X	-	-	1	-	X	X	X	X	A	TV
Napthalene	2	2	2	2	2	2	1	1	A	A	TV
Naptha	2	2	2	2	2	2	2	2	A	X	TVB
Nickel											
Nickel Chloride	X	X	X	-	X	2	-	-	X	A	TEVNB
Nickel Sulfate	X	X	-	2	-	-	2	2	X	A	TEVNB
Nitric											
Nitric Acid (100%)	1	X	X	2	X	X	2	-	X	X	TV
Nitric Acid (50%)	X	X	X	1	X	X	2	-	X	X	TV
Nitric Acid (30%)	X	X	X	1	X	X	1	-	X	X	TV
Nitrobenzene	1	2	2	-	2	2	2	2	A	A	T
Oils											
Castor Oil	2	2	2	1	2	1	2	2	A	A	TEVNB
Coconut Oil	2	-	2	-	3	2	2	2	A	A	TVB
Corn Oil	2	2	2	-	2	2	-	2	A	A	TVNB
Cotton Seed Oil	2	2	2	-	2	1	2	2	A	A	TVNB
Fuel Oil	2	2	2	2	2	2	2	2	A	X	TVNB
Linseed Oil	2	2	2	2	2	2	2	2	A	A	TVNB
Mineral Oil	2	1	-	-	2	1	1	2	A	A	TVNB
Silicon Oil	2	1	2	-	2	-	2	2	A	A	TEVB
Vegetable Oil	2	2	2	1	2	1	1	1	A	X	TVNB
Oleic Acid	2	3	2	2	2	1	-	1	A	X	TB
Oleum	2	X	X	-	2	X	2	2	X	X	TV
Oxalic Acid (Sat.)	2	-	2	2	X	2	X	X	X	A	TEV
Oxygen	2	2	2	-	2	2	2	2	X	X	TEVNB
Palmitic Acid (Sat.)	2	3	2	-	3	2	2	2	X	A	TVB
Paraffin	2	2	2	2	2	2	2	2	A	A	TVNB
Perchloroethylene	2	2	2	2	2	1	-	-	X	X	TV
Petrolatum	2	-	2	-	3	2	2	2	A	-	TVNB
Phenol (Carbolic Acid)	1	1	X	1	2	1	-	1	X	X	TV
Phosphoric Acid											
Phosphoric Acid (25-50%)	X	X	2	1	X	X	-	-	X	A	TEVN
Phosphoric Acid (50-85%)	X	X	X	1	X	3	-	-	X	A	TEV
Photographic Solutions	-	-	-	-	X	1	1	1	X	X	TVNB
Phthalic Anhydride	-	2	2	1	2	1	1	1	X	X	TEV

Ratings given are based at 21°C (70°F)



## Corrosion Resistance of Coupling Material

Agent	Aluminium	Brass	Bronze	Hastelloy, C-276	Malleable Iron Carbon Steel	Monel	Stainless Steel, 304	Stainless Steel, 316	Nylon	Polypropylene	Seal Material
Picric Acid	1	X	X	2	X	X	2	2	X	-	TEVNB
Plating Solutions											
Brass Plating Solution	-	-	-	1	-	-	-	2	X	A	TEVNB
Cadmium Plating Solution	-	-	-	1	-	-	-	2	X	A	TEVNB
Chrome 40% Plating Solution	X	2	2	1	X	X	2	2	X	A	TEVN
Copper (Cyanide) Plating Solution	-	-	-	1	-	-	-	-	X	A	TEVNB
Gold Plating Solution	-	-	-	1	-	-	-	1	X	A	TEVNB
Iron PLating Solution	-	-	-	-	-	-	-	-	X	A	TEVB
Lead Plating Solution	-	-	-	-	-	-	1	1	X	A	TEVNB
Nickel Plating Solution	-	-	-	1	-	-	1	1	X	A	TEVNB
Silver Plating Solution	-	-	-	1	-	-	1	1	X	A	TEVNB
Tin Plating Solution	-	-	-	1	-	-	-	3	X	A	TEVNB
Zinc Plating Solution	-	-	-	1	-	-	-	-	X	A	TEVNB
Potassium											
Potassium Acetate	X	X	X	-	2	-	-	-	A	A	TEVB
Potassium Bicarbonate (30%)	X	2	-	2	2	2	1	1	A	A	TEVNB
Potassium Carbonate (50%)	X	2	X	2	2	2	1	1	A	A	TEVNB
Potassium Chlorate (30%)	2	X	X	-	2	2	2	1	X	A	TEVNB
Potassium Chloride (30%)	X	X	2	-	2	1	-	-	A	A	TEVNB
Potassium Chromate (30%)	2	2	2	2	-	2	2	2	X	A	TEVB
Potassium Cyanide Solution (30%)	X	X	X	2	2	2	2	2	X	A	TEVNB
Potassium Dichromate (30%)	1	2	2	2	2	2	1	1	X	A	TEVB
Potassium Hydroxide (90%)	X	X	X	2	-	2	X	-	X	A	TENB
Potassium Nitrate (80%)	1	2	2	2	2	2	2	2	X	A	TEVNB
Potassium Permanganate (20%)	2	2	2	1	2	2	2	2	X	A	TEVN
Potassium Sulfate (10%)	1	2	2	1	2	1	1	1	A	A	TEVNB
Propane	1	1	1	2	2	1	2	2	X	X	TVB
Propylene Gylcol	2	2	2	2	2	2	2	2	A	A	TVNB
Propylene Oxide (90%)	-	-	-	-	-	-	1	1	X	X	TE
Pyridine	2	2	2	-	2	2	2	2	A	X	T
Pyrogalllic Acid	2	2	2	2	2	2	2	2	X	X	TVNB
Silver Nitrate	X	X	X	-	X	X	2	1	X	A	TEVNB
Soap Solutions	2	2	2	1	2	2	2	2	A	A	TEVNB
Sodium											
Sodium Acetate	1	2	2	-	X	2	2	2	A	A	TEN
Sodium Bicarbonate (20%)	2	2	2	1	3	1	1	1	A	A	TEVNB
Sodium Bisulfate	X	-	2	2	2	-	-	-	A	A	TEVNB
Sodium Bisulfite	X	2	X	2	X	-	-	-	A	A	TEVNB
Sodium Borate	2	2	2	2	3	2	2	2	A	A	TEVNB
Sodium Perborate (10%)	2	X	2	2	2	2	2	2	X	A	TEVNB
Sodium Carbonate	X	2	-	2	2	1	-	2	A	A	TEVNB
Sodium Chlorate (50%)	2	2	2	1	X	1	2	2	X	A	TEVNB
Sodium Cyanide	X	X	X	2	2	X	-	-	A	A	TEVNB
Sodium Dichromate	2	X	X	1	2	-	2	2	X	A	TE
Sodium Hydroxide (70%)	X	X	X	1	3	1	2	2	X	A	TENB
Sodium Hydroxide (50%)	X	X	3	1	3	1	1	-	X	A	TENB
Sodium Hydroxide (30%)	X	2	3	2	2	1	1	1	X	A	TENB
Sodium Chloride (30%)	X	2	2	2	2	1	-	-	X	A	TEVNB
Sodium Hypochlorite	X	X	X	-	X	X	-	-	X	A	TEV

Ratings given are based at 21°C (70°F)



## Corrosion Resistance of Coupling Material

Agent	Aluminium	Brass	Bronze	Hastelloy, C-276	Malleable Iron Carbon Steel	Monel	Stainless Steel, 304	Stainless Steel, 316	Nylon	Polypropylene	Seal Material
Sodium Metaphosphate	X	X	2	-	X	2	2	2	X	X	TEVNB
Sodium Nitrate (40%)	1	2	-	-	2	2	1	1	A	A	TENB
Sodium Perborate (10%)	2	X	2	2	2	2	2	2	X	A	TEVNB
Sodium Peroxide (10%)	2	X	X	2	2	2	2	2	X	A	TEVNB
Sodium Silicate	1	2	2	2	2	2	2	2	A	A	TEVNB
Sodium Sulfate	-	2	2	2	2	-	-	1	A	A	TEVNB
Sodium Sulfide (50%)	X	X	X	2	2	2	-	2	X	A	TEVNB
Sodium Thiosulphate	2	X	X	2	X	2	2	2	A	A	TEVNB
Stannic Chloride	X	X	X	-	X	X	X	X	X	A	TEVNB
Stannous Chloride	X	X	X	2	X	-	X	-	X	X	TEVNB
Steam	-	-	-	-	-	-	-	-	X	-	-
Stearic Acid	2	3	2	1	3	3	2	1	A	A	TVNB
Stoddard's Solvent	2	2	2	1	2	2	2	2	X	A	TVB
Sugar Liquors (Cane)	1	2	1	-	2	2	2	2	A	A	TEVNB
Sugar Liquors (Beet)	1	2	1	-	2	1	1	1	A	A	TEVNB
Sulfate Liquors	2	X	X	2	3	2	-	2	X	A	TVNB
Sulfite Liquors	X	X	-	1	X	X	2	2	X	X	TVNB
Sulfur Chloride	X	-	X	2	X	X	-	-	X	X	TV
Sulfur Dioxide (Dry)	2	2	2	2	1	2	-	2	X	A	TE
Sulfur Trioxide	2	2	X	2	2	2	-	2	X	X	TEV
Sulfuric Acid (TO 10%)	X	2	X	1	X	X	X	X	X	A	TEVNB
Sulfuric Acid (100%)	X	X	X	1	2	X	-	-	X	X	TV
Sulfurous Acid	2	2	X	-	X	X	X	-	X	A	TV
Tannic Acid	X	-	X	-	X	2	2	2	X	A	TEVNB
Tanning Liquors	1	-	2	1	-	-	1	1	X	A	TVNB
Tartaric Acid	-	-	2	2	-	-	1	1	A	A	TVNB
Titanium Tetrachloride	X	X	X	2	2	2	-	2	X	X	TV
Toluene	1	1	1	1	1	1	1	1	A	X	TVB
Tetrahydrofuran	X	-	2	1	1	-	1	2	A	X	T
Tomato Juice	2	-	3	2	3	2	2	2	X	A	TEVNB
Trichloroethylene	1	-	2	1	2	-	-	-	A	X	TV
Triethanolamine	2	X	2	2	2	2	2	2	A	X	TEVN
Triethylamine	-	-	-	-	-	2	2	2	A	X	TVB
Trisodium Phosphate (10%)	X	2	-	1	2	2	1	1	A	A	TVNB
Turpentine	2	X	2	2	2	1	1	1	X	X	TVB
Urea (50%)	2	-	2	-	2	2	2	2	A	A	TEVNB
Urine	-	-	-	-	2	-	1	1	X	A	TEVNB
Vinegar	2	X	2	2	2	2	2	2	X	A	TEVN
Water Acid (Mine)	X	X	X	1	X	-	-	-	X	A	TEVNB
Water (Distilled)	X	2	2	1	X	X	2	2	A	A	TEVNB
Water (Sea)	2	2	2	1	X	2	2	2	A	A	TEVNB
Whiskey	X	2	2	1	2	2	1	1	X	A	TEVNB
White Liquor (Pulp)	2	-	X	2	X	X	2	2	X	A	TEVNB
Wine	X	2	2	1	X	2	1	1	X	A	TEVNB
Xylene	2	2	2	1	2	2	2	2	A	X	TV
Zinc											
Zinc Chloride	X	X	X	2	X	-	X	2	A	A	TEVNB
Zinc Nitrate	-	-	-	-	-	-	2	2	X	A	TEVNB
Zinc Sulfate (50%)	X	2	2	2	X	2	1	1	X	A	TEVNB

Ratings given are based at 21°C (70°F)



## Identifying Pipe Threads



It is important to identify the threads. Required before ordering couplings!

Identifying threads can sometimes be the most difficult and frustrating part of coupling selection. However, without the right combination of threads, you may not provide a functional or safe connection.

The diameters, threads per inch (TPI), and thread pitch, etc. are necessary to completely identify a thread. Ring, plug and, GO/ NOGO gauges are required to accurately gauge or identify threads. In the field, in the absence of these gauges, thread leaf gauges can be used to identify the "Threads Per Inch" (TPI) and the thread pitch. On threads you have determined to be straight threads, a caliper can be used to measure the "Outside Diameter of the Male" (ODM) or the "Inside Diameter of the Female" (IDF). A caliper can also be used to take measurements of tapered thread diameters. However, these are more difficult to define because of the taper. Fortunately, there are few tapered threads to deal with and these can usually be identified from the nominal ODM and the TPI.

However, identifying the thread may not fully identify what is needed in a mating fitting. The application is the primary **limiting factor on the thread type used**. Dixon™ offers products with a wide variety of threads used with hose, pipe, and hydraulics.

When attempting to choose a fitting, it is always advisable to first identify the thread to which it must connect. This may entail checking with a fitting or equipment manufacturer.

**The fire hose thread specifications for some local municipal fire equipment and hydrants may vary according to local specifications.** These can generally be most easily identified by contacting the local fire department responsible for the hydrant. The most common thread used on fire equipment is National Standard Thread (NST), also known as National Hose thread (NH).

### When it is not possible to identify the thread:

- 1) Determine the number of threads per inch by measuring the distance from peak of thread to peak of thread across the largest number of whole threads. Then divide the number of threads by the measurement (this will provide the TPI).
- 2) Check to see if the thread is straight or tapered.
  - a) Straight Threads  
Measure the "Outside Diameter of the Male" (ODM) or the "Inside Diameter of the Female" (IDF), from peak of thread to peak of thread.
  - b) Tapered Threads  
Measure the "Outside Diameter of the Male" (ODM) at the large end and the small end, or the "Inside Diameter of the Female" (IDF) at the large end and the small end, from peak of thread to peak of thread. Then measure the Outside Diameter (OD) of the unthreaded pipe.

Once the application and these two pieces of information have been determined, the thread can generally be determined. **If in doubt, contact your local Dixon™ office.**

#### STRAIGHT THREAD

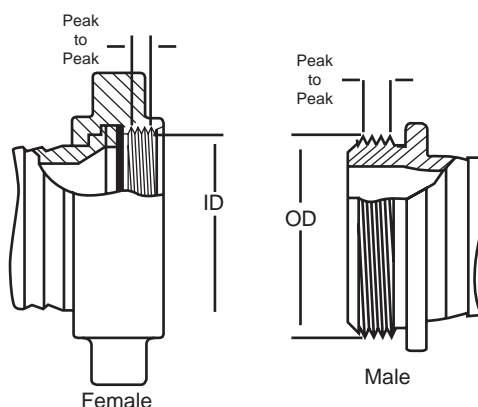

#### TAPERED THREAD

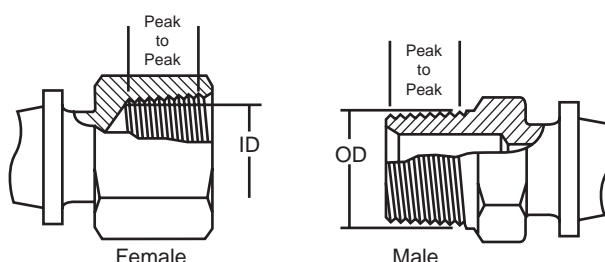

## Pipe Threading Information

Abbreviation	System Name	Compatibility	Seal Method
<b>BSPP</b>	British Standard Pipe Parallel	Male BSPP with Female BSPP Female BSPP with Male BSPP Female BSPP with Male BSPT <sub>r</sub>	Washer Washer Washer
<b>BSPT<sub>r</sub></b>	British Standard Pipe Taper	Male BSPT <sub>r</sub> with Female BSPT <sub>r</sub> Male BSPT <sub>r</sub> with Female BSPP Female BSPT <sub>r</sub> with Male BSPT <sub>r</sub> <i>Female BSPT<sub>r</sub> not compatible with Male BSPP</i>	Thread Washer Thread
<b>CHT</b>	American Standard Fire Hose Thread (1" National Hose Thread is Chemical Hose Thread, also known as Booster Hose Thread)	1" Male NH (NST) with 1" Female NH (NST) 1" Female NH (NST) with 1" Male NH (NST) 1" Thread is used on both ¾" hose and 1" hose. <i>Not compatible with other systems</i>	Washer Washer
<b>GHT</b>	Garden Hose Thread	Male GHT with Female GHT Female GHT with Male GHT Thread is same for all size hose <i>Not compatible with other systems</i>	Washer Washer
<b>IPS</b>	Iron Pipe Straight Thread	Generic Name for Straight Pipe Thread See NPSH for compatibility	Washer
<b>IPT</b>	Iron Pipe Thread	Generic Name for All Pipe Thread	
<b>JIC</b>	Joint Industrial Council	Used with other mating JIC threads	Mechanical
<b>NH or NST</b>	American Standard Fire Hose Coupling Thread (National Hose thread also known as National Standard Thread)		Washer Washer
<b>NPT</b>	American Standard Taper Pipe Thread (National Pipe Tapered)	Male NPT with Female NPT Male NPT with Female NPTF Male NPT with Female NPSM Male NPT with Female NPSH Female NPT with Male NPT Female NPT with Male NPTF Female NPT not compatible with Male NPSM or Male NPSH	Thread Thread Washer Washer Thread Thread
<b>NPTF</b>	American Standard Taper Pipe Fuel Dryseal Thread	Male NPTF with Female NPTF Male NPTF with Female NPT Male NPTF with Female NPSM Male NPTF with Female NPSH Female NPTF with Male NPTF Female NPTF with Male NPT Female NPTF with Male NPSM or NPSH <b>Note:</b> <i>NPTF with NPTF threads do not require sealant for the initial use. After that, sealant is required.</i>	Thread Thread Washer Washer Thread Thread Not Compatible
<b>NPSH</b>	American Standard Straight Pipe for Hose Couplings (National Pipe Straight Hose)	Male NPSH with Female NPSH Female NPSH with Male NPSH Female NPSH with Male NPT Female NPSH with Male NPTF Female NPSH with Male NPSM	Washer Washer Washer Washer Washer
<b>NPSM</b>	American Standard Straight Mechanical Joints (National Pipe Straight Mechanical)	Male NPSM with Female NPSM Male NPSM with Female NPSH Female NPSM with Male NPSM Female NPSM with Male NPT Female NPSM with Male NPTF	Seal can be either mechanical or washer. Mating fittings must be of same type.
<b>SIPT</b>	Straight Iron Pipe Thread	Generic name for Straight Pipe Thread	Washer
<b>TIPT</b>	Tapered Iron Pipe Thread	Generic name for Tapered Pipe Thread	Thread

## Pipe Thread Sealing Tips

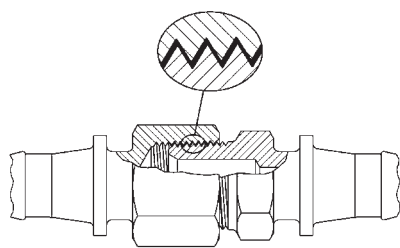

### Thread Seal Type

- A seal is obtained by applying a sealant to the male thread before engaging.
- The sealant is used to prevent spiral leakage.
- Thread tape or paste is the preferred sealant in this type of application.

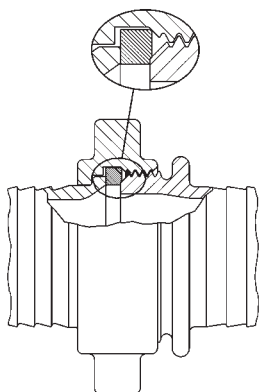

### Washer Seal Type

- A seal is obtained when the male thread is tightened down onto the washer of the female assembly.
- The washer should be inspected regularly and replaced as needed to prevent leakage.

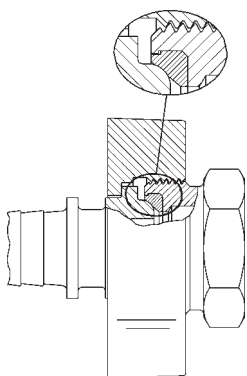

### Mechanical Seal Type

- A seal is obtained through metal-to-metal contact or metal-to-seal contact, i.e. JIC couplings have a metal-to-metal seal. EZ-Boss™ Ground Joint couplings have a metal-to-seal contact (as shown above).
- The couplings should be retightened as needed to prevent leakage.

## Thread Sealing Tips

Sealing NPT threads can be an exasperating experience if certain techniques are not followed. The following tips will help alleviate many common problems in thread sealing:

1. Always use some type of sealant (tape or paste) and apply sealant to male thread only. If using a hydraulic sealant, allow sufficient curing time before system is pressurised.
  2. When using tape sealant, wrap the threads in a clock-wise motion starting at the first thread and, as layers are applied, work towards the imperfect (vanishing) thread. If the system that the connection being made to cannot tolerate foreign matter (i.e. air systems), leave the first thread exposed and apply the tape sealant as outlined above.
  3. When using paste sealant, apply to threads with a brush, using the brush to work the sealant into the threads. Apply enough sealant to fill in all the threads all the way around.
  4. When connecting one stainless steel part to another stainless steel part that will require future disassembly, use a thread sealant that is designed for stainless steel. This stainless steel thread sealant is also useful when connecting aluminium to aluminium that needs to be disconnected in the future. These two materials gall easily, and if the correct sealant is not used, it can be next to impossible to disassemble.
  5. When connecting parts made of dissimilar metals (i.e. steel and aluminium), standard tape or paste sealant performs satisfactory.
  6. For sizes 2" and below, tape or paste performs satisfactory. When using thread tape, four wraps (covering all necessary threads) is usually sufficient.
  7. For sizes 2½" and above, thread paste is recommended. If thread tape is used, eight wraps (covering all necessary threads) is usually sufficient. Apply more wraps if necessary.
  8. For stubborn to seal threads, apply a normal coating of thread paste followed by a normal layer of thread tape.
  9. For extremely stubborn to seal threads, apply a normal coating of thread paste followed by a single layer of gauze bandage followed by a normal layer of thread tape.
- Caution!** When this procedure is done, the connection becomes permanent. Extreme measures will be necessary to disconnect these components. All other measures to seal the threads should be explored prior to use of this technique.
10. Over-tightening threads can be just as detrimental as insufficient tightening. For sizes 2" and below, hand tighten the components and, with a wrench, tighten 3 full turns. For sizes 2½" and above, hand tighten the components and, with a wrench, tighten 2 full turns.



## Nominal Dimensions of Standard Pipe Threads

**ODM** - Outside Diameter of the Male

**IDF** - Inside Diameter of the Female

**TPI** - Threads Per Inch

Size (inch)	Pipe OD	Tapered Threads		Straight Threads											
		NPT	BSPT	NPSH			NPSM			NST (NH)			BSPP		
		TPI	TPI	TPI	ODM (max)	IDF (min)	TPI	ODM (max)	IDF (min)	TPI	ODM (max)	IDF (min)	TPI	ODM (max)	IDF (min)
1/8	.405	27	28	-	-	-	27	0.397	0.358	-	-	-	-	0.383	0.337
1/4	.504	18	19	-	-	-	18	0.526	0.468	-	-	-	-	0.516	0.450
3/8	.675	18	19	-	-	-	18	0.662	0.603	-	-	-	-	0.656	0.588
1/2	.840	14	14	14	0.8248	0.7395	14	0.823	0.747	-	-	-	-	0.825	0.733
3/4	1.050	14	14	14	1.0353	0.9500	14	1.034	0.958	8	1.375	1.2246	-	1.041	0.950
1	1.315	11.5	11	11.5	1.2951	1.1921	11.5	1.293	1.201	8	1.375	1.2246	11	1.309	1.193
1 1/4	1.660	11.5	11	11.5	1.6399	1.5369	11.5	1.638	1.546	-	-	-	11	1.650	1.534
1 1/2	1.900	11.5	11	11.5	1.8788	1.7758	11.5	1.877	1.785	9	1.990	1.8577	-	1.882	1.766
2	2.375	11.5	11	11.5	2.3528	2.2498	11.5	2.351	2.259	-	-	-	11	2.347	2.231
2 1/2	2.875	8	11	8	2.8434	2.6930	8	2.841	2.708	7.5	3.068	2.9104	11	2.960	2.844
3	3.500	8	11	-	-	-	8	3.467	3.334	6	3.623	3.5306	11	3.460	3.344
4	4.500	8	11	-	-	-	8	4.466	4.333	4	5.010	4.7111	-	4.450	4.334
4 1/2	-	-	-	-	-	-	-	-	-	4	5.760	5.4611	11	-	-
5	5.563	8	11	-	-	-	8	5.528	5.395	4	6.260	5.9602	11	5.450	5.359
6	6.625	8	11	-	-	-	8	6.585	6.452	4	7.025	6.7252	-	6.450	6.359
8	8.625	8	-	-	-	-	-	-	-	-	-	-	-	-	-
10	10.750	8	-	-	-	-	-	-	-	-	-	-	-	-	-
12	12.750	8	-	-	-	-	-	-	-	-	-	-	-	-	-

GHT (3/4") - 1.0625 ODM, 11 1/2 TPI

**NOTE:** Female NPT (Tapered Pipe) thread is not available on hose swivel nuts. Dimensions in inches.

## Normal Engagement Length of NPT Thread in Inches ("A") \*

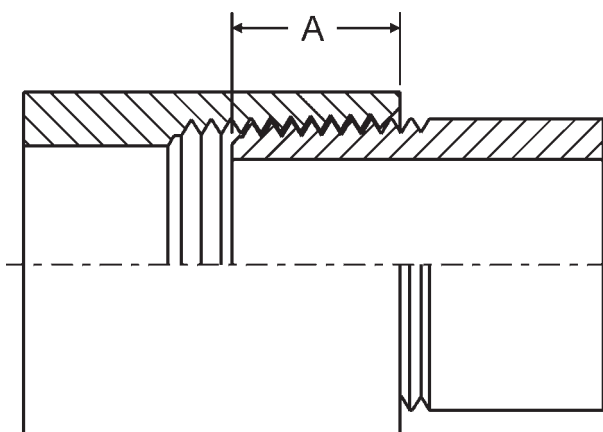

\* Dimensions given do not allow for variations in tapping or threading.

Size (inch)	"A" (inch)
1/8	1/4
1/4	3/8
3/8	3/8
1/2	1/2
3/4	9/16
1	11/16
1 1/4	11/16
1 1/2	11/16
2	3/4
2 1/2	15/16
3	1
4	1 1/8
5	1 1/4
6	1-5/16
8	1-7/16
10	1 5/8
12	1 3/4



## Tank Truck Flanges

(TTMA Drilling)

Nominal Pipe Size (inch)	Flange OD	Thickness (inch) <sup>1</sup>	Diameter of Bolt Circles (inch)	No. of Bolts	Diameter of Bolt Holes	Diameter of Bolts
3	5 $\frac{1}{2}$	$\frac{3}{8}$	4 $\frac{7}{8}$	8	7/16	$\frac{3}{8}$
4	6 $\frac{3}{8}$	$\frac{3}{8}$	5 $\frac{7}{8}$	8	7/16	$\frac{3}{8}$
5	8 $\frac{1}{2}$	$\frac{3}{8}$	8 $\frac{1}{8}$	12	7/16	$\frac{3}{8}$

<sup>1</sup> Listed thickness is for aluminium flanges.

## ANSI B16.5 Flanges

(Class 150 & Class 300)

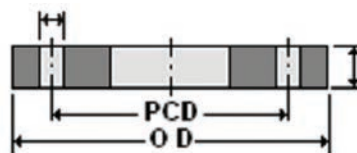
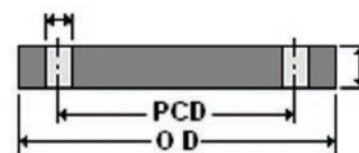

Plate Slip-On Welding



Blank

Nominal Bore Size (inch)	Class	Flange OD (mm)	PCD (mm)	No. of Bolts	Bolt (inch)	Bolt Hole Diameter (mm)	Flange Thickness (mm)
1/2	150	90	60.5	4	1/2	16	11.5
	300	95	66.5				14.5
3/4	150	100	70	4	1/2	16	13
	300	120	82.5		5/8	20	16
1	150	110	79.5	4	1/2	16	14.5
	300	125	89		5/8	20	17.5
1 1/4	150	120	89	4	1/2	16	16
	300	135	98.5		5/8	20	19.5
1 1/2	150	127	98.5	4	1/2	16	17.5
	300	155	114.5		3/4	22	21
2	150	150	120.5	4	5/8	20	19.5
	300	165	127	8	5/8	20	22.5
2 1/2	150	180	139.5	4	5/8	20	22.5
	300	190	149	8	3/4	22	22.5
3	150	190	152.5	4	5/8	20	24
	300	210	168.5	8	3/4	22	29
3 1/2	150	215	178	8	5/8	20	24
	300	230	184		3/4	22	30.5
4	150	230	190.5	8	5/8	20	24
	300	255	200		3/4	22	32
5	150	255	216	8	3/4	22	24
	300	280	235				35
6	150	280	241.3	8	3/4	22	25.5
	300	320	270				37
8	150	345	298.5	8	3/4	22	29
	300	380	330				12
10	150	405	362	12	7/8	26	30.5
	300	445	387.5				16
12	150	485	432	12	7/8	26	32
	300	520	451				16
14	150	535	476	12	1	30	35
	300	585	514.5				20
16	150	600	540	16	1	30	37
	300	650	571.5				20
18	150	635	578.5	16	1 1/8	33	40
	300	710	628.5				24
20	150	700	635	20	1 1/8	33	43
	300	775	689				24
24	150	815	749.5	20	1 1/8	33	48
	300	915	813				24
30	150	985	914	28	1 1/4	35	54
	300	1090	997				28
36	150	1170	1086	32	1 1/2	41	60.3
	300	1270	1168				32

### Flange Bolt Tightening Sequence

(Use appropriate gaskets and bolts)

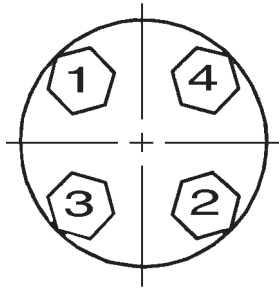

4 Bolt

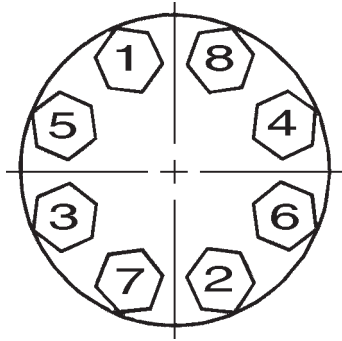

8 Bolt

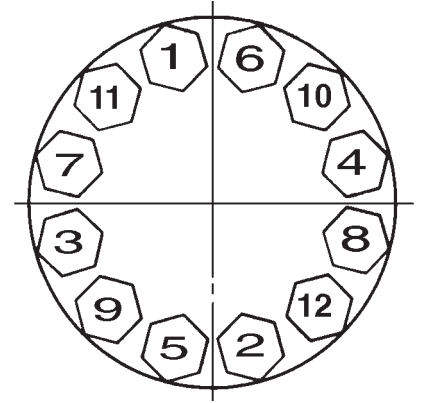

12 Bolt

### Flange Diagrams - Threaded Applications

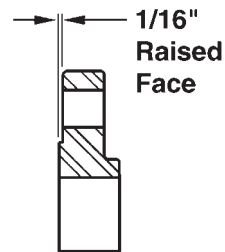
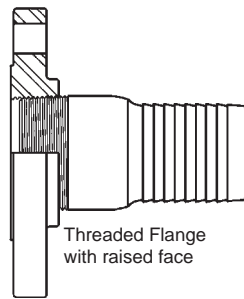

### Welded Applications

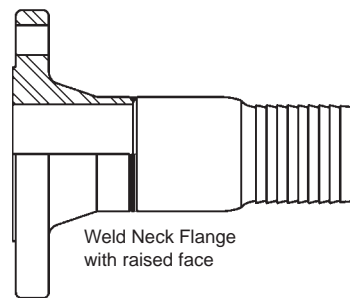
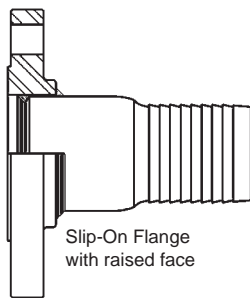

### Floating Applications

(Flange Free to Swivel)

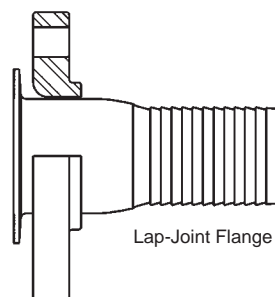
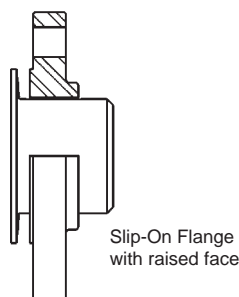

## Pipe Threads

Pipe threads are either tapered or straight (parallel). The two styles may or may not be compatible.

### NPT vs. BSP (British Standard Pipe)

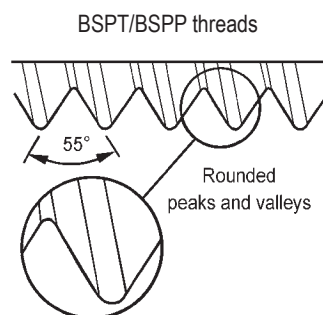

BSP threads are common in many countries outside the United States. BSP consists of two types of threads - BSPT (British Standard Pipe Taper) and BSPP (British Standard Pipe Parallel).

BSPT threads have a slight taper similar to NPT. BSPP threads are straight (parallel) threads and have the same thread angle, shape and threads per inch (pitch) as BSPT threads. *BSPT and BSPP threads should not be substituted for NPT threads.*

NPT and BSPT/BSPP threads have different angles, shape, and (in most cases) threads per inch (pitch). The thread angle is 60° for NPT threads; 55° for BSPT/BSPP threads. NPT threads are flattened at the peaks and valleys, while BSPT/BSPP threads are rounded.

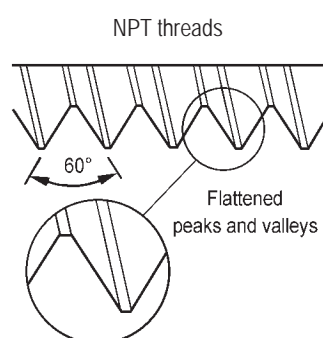

Nominal Pipe Size	Threads per inch	
	NPT	BSPT / BSPP
1/16"	27	---
1/8"	27	28
1/4"	18	19
3/8"	18	19
1/2"	14	14
3/4"	14	14
1"	11½	11
1¼"	11½	11
1½"	11½	11
2"	11½	11
2½"	8	11
3"	8	11
3½"	8	11
4"	8	11
5"	8	11
6"	8	11
8"	8	11

#### Tapered threads

Tapered threads are the most common type of thread available. As the name implies, they have a slight taper. When mated together and tightened, the threads compress and may form a seal. Usually a thread sealant is required. The mating threads both hold the fitting in place and seal the connection. Some confusion may result from the use of NPT, FPT, and MPT in describing threads. Both FPT and MPT are NPT threads, with FPT meaning female threads (internal) and MPT meaning male threads (external).

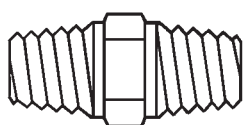

tapered threads

NPTF (Dryseal) threads are modified NPT threads, which are less likely to leak without a sealant. For a leak-free seal, we recommend using a sealant compound or PTFE tape. You can use NPTF threads with NPT threads, but you'll lose some of the leak-free characteristics.

#### Straight threads

Straight (parallel) threads are used for mechanical joining. They serve one purpose - to hold a fitting in place. As a result, an O-ring (elastomer), hard metal seal or a soft seat seal is required. Straight pipe threads include NPSM (National Pipe Straight Mechanical), and NPSH (National Pipe Straight Hose). Sizing and pitches may differ from the NPT threads

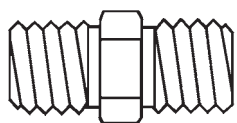

straight threads

Less common straight threads are GHT (garden hose) and NST (fire hose coupling).

## Cam & Groove Specifications

### Design Information

Applications	How does it work?
The Dixon™ cam & groove coupling is a reliable quick connect coupling for use on hose, pipe, tubing and tanks conveying a wide variety of liquids, dry bulk materials and vapours including cooling water, fuels, chemicals, cosmetics, food products, adhesives, dyes, pharmaceuticals, pellets, and much more.	The coupling is connected by simply opening the coupler arms and inserting the adaptor into the coupler. The two cam arms are then closed under normal hand pressure to complete the joint.

The Dixon™ range of cam & groove (Camlock) couplers and adaptors are manufactured to interchange with all product produced to Mil Spec A-A 59326, which supersedes Mil-C-27487. No standard exists for the ½" (15mm) and 8" (200mm) fittings and generally these sizes do not interchange with other manufacturers' products.

### Maximum Pressure Ratings

**Designed for use with liquids.** Consult Dixon Europe for specific recommendations. Recommendations based on the use of mating Dixon™ fittings at ambient temperature **21°C (70°F)** with standard Buna-N seal installed. For use at elevated temperature or other unusual operating conditions, consult your Dixon™ representative.

For Aluminium, Bronze, Brass, Stainless Steel & Malleable Camlocks:						
Sizes (mm)	15	20-50	65	75	100	125-150
Pressure (PSI)	150	250	150	125	100	75

For Polypropylene & Nyglass Camlocks:				
Sizes (mm)	15-25	32-50	75	100
Pressure (PSI)	125	100	75	50

### Polypropylene & Nyglass Cam & Groove Temperature vs Pressure Rating

Polypropylene & Nyglass	Size	15mm - 50mm			75mm - 100mm		
	Temperature °C (°F)	-18° (0°)	21° (70°)	65° (149°)	-18° (0°)	21° (70°)	65° (149°)
	Pressure (PSI)	100	125	70	70	90	50

### Materials

The Dixon™ range of cam & groove (Camlock) couplers and adaptors are manufactured from the following materials.

- Aluminium conforming to the requirements of ASTM B 26/B 26M Grade 356.0 – T6.
- Stainless steel grade CF8M (316 Equivalent) in accordance with the requirements of ASTM-A351
- Bronze grade UNS C84400 in accordance with the requirements of ASTM-B584
- Polypropylene 30% glass filled
- Nyglass 30% glass filled

Body	Levers	Pins
Die Cast Aluminium	Brass	Mild Steel
Bronze	Stainless Steel	Stainless Steel
Polypropylene	Stainless Steel	Stainless Steel
Nyglass	Stainless Steel	Stainless Steel
Stainless Steel	Stainless Steel	Stainless Steel

### Welding of Camlocks

**Couplings made using the diecast process must NOT be welded.** Although bronze sand cast couplings made from the above materials may be welded using the appropriate welding equipment and compatible filler material, any modifications to the product will void your warranty. Welding the couplings changes the integrity of the coupling therefore Dixon Europe will not accept any responsibility for modified couplings.

### Cam & Groove Nominal Take-Up Lengths

Size (inch)	A (inch)	Size (inch)	A (inch)
½	0.97	3	1.78
¾	0.97	4	1.84
1	1.20	5	2.00
1¼	1.44	6	2.13
1½	1.50	(Boss-Lock™) 8	2.06
2	1.81	(Andrews) 8	3.22
2½	1.82		

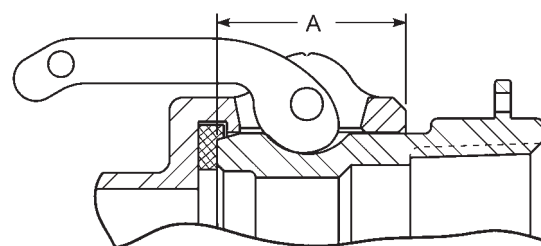

**Camlock Safety**

- **UNDER NO CIRCUMSTANCES** should cam & groove (camlock) couplings be used in compressed air or steam applications.
- Dust caps and dust plugs are not to be used in any pressure applications for safety and environmental reasons.

## Claw Coupling Specifications

### A Type European Pattern

<b>Materials Available:</b>	SG iron ISO 1083 zinc plated 316 stainless steel CF8M
<b>Seal Material:</b>	Natural rubber (NR) FKM Nitrile available on request (NBR, Buna N)
<b>Temperature Range:</b>	Natural rubber seal <b>-29°C to 71°C (-20°F to 159°F)</b> FKM seal <b>-30°C to 200°C (-22°F to 392°F)</b>
<b>Working Pressure:</b>	Standard seal <b>500 PSI</b> , Bellow seal <b>1000 PSI</b>
<b>Compatible with:</b>	Atlas Copco, Ludecke
<b>Size Range:</b>	3/8" to 1 1/4" hose end and threaded
<b>Thread Type:</b>	Male and female BSP NPT available on request



### Surelock™ Australian Pattern

<b>Materials Available:</b>	SG iron ISO 1083 zinc plated 316 stainless steel CF8M
<b>Seal Material:</b>	Natural rubber (NR) FKM Nitrile available on request (NBR, Buna N)
<b>Temperature Range:</b>	Natural rubber seal <b>-29°C to 71°C (-20°F to 159°F)</b> FKM seal <b>-30°C to 200°C (-22°F to 392°F)</b>
<b>Working Pressure:</b>	3/8" to 2" <b>1000 PSI</b> ; 3" <b>500 PSI</b>
<b>Size Range:</b>	3/8" to 3" hose end and threaded 2" shouldered
<b>Thread Type:</b>	Male and female BSP NPT available on request



### Air King™ American Pattern

<b>Materials Available:</b>	Malleable iron ASTM A47 316 stainless steel CF8M Brass C84400
<b>Seal Materials:</b>	Natural rubber (NR) Neoprene FKM
<b>Temperature Range:</b>	Rubber seal <b>-29°C to 71°C (-20°F to 159°F)</b> Neoprene seal <b>-29°C to 88°C (-20°F to 392°F)</b> FKM seal <b>-30°C to 200°C (-22°F to 190°F)</b>
<b>Working Pressure:</b>	<b>150 PSI at 21°C (70°F)</b>
<b>Size Range:</b>	3/8" to 1" hose end and threaded
<b>Thread Type:</b>	Male and female BSP or NPT

### Minsup™ Claw Couplings

Minsup™ claw couplings are a universal hose coupling that provide quick, safe and reliable connections. Claw couplings are designed with a common or universal claw which enables differing hose sizes and nominal bores sizes to be connected. Claw couplings are most commonly used for conveying air and water and are not be used for steam applications.

Common industry applications: under ground and surface mining, mineral processing, compressor and air tool industries, hire companies.

All Minsup™ Claw Couplings comply with AS 2554 and AS2660 – Hose and Hose Assemblies for Air/Water.

### Minsup™ Claw Couplings with Crimped Ferrule

Fitting maximum working pressure: **300 PSI**. Assembly maximum working pressure will depend on the type of hose used. If unsure contact Dixon Europe to enquire about hose assembly testing. Tested and approved for use with:

- A190 Super Air Water Hose (**300 PSI** working pressure)
- A102 Contractors Yellow Air Hose (**200 PSI** working pressure)

For alternative hose types, contact Dixon Europe for suitability. For crimp specifications and procedures contact Dixon Europe.

### Materials

Ferrule	Zinc plated mild steel
Coupling	SG iron zinc plated
Seal	Natural rubber (FKM available on request)

### Locking Pins

The use of a Minsup™ safety locking pin is necessary to ensure that Minsup™ A Type and Surelock™ claw couplings will not become accidentally disconnected. This ensures that the fittings are properly connected as the pin will not go through the holes in both couplings until the couplings are locked into place.

### The Importance of Safety Hose

Constant vibration created by air drills, pavement breakers, etc., is destructive to air hose couplings, especially the quick-acting type. To provide protection, connect one end of a 1 to 3 metre length of air hose to the tool using the heat-treated No. 3500 Steel Nipple which withstands vibration for a longer period. Connect the other end of whip hose to the air supply with the quick-acting coupling.

Whip hose should remain permanently connected to the tool and should be the same diameter as the supply line hose.



**NOTE: Air King™ is for air and water service only**

## Boss™ Coupling System

**Purpose:** Boss™ couplings supply a convenient threaded fitting needed to connect two lengths of hose, or a single length to a male or female threaded (NPT/ BSP) outlet.

**Features:** The spud part of the coupling serves as one half of the connection and is usually fixed to the equipment. The stem part that is clamped to the hose is the other half. The two halves are connected or disconnected by rotating the wing nut on the spud. When connected, they achieve a mechanical as well as a pressure seal.

**Services:** Boss™ couplings are all-purpose hose couplings, universally recommended for steam hose connections. They are also widely used for air, water, fluid petroleum chemicals, and liquid petroleum gas up to 1" ID. Boss™ couplings can be applied to many types of rubber, synthetic, plastic, metallic, or semi-metallic hose. Consult your local Dixon™ branch for specific media capabilities.

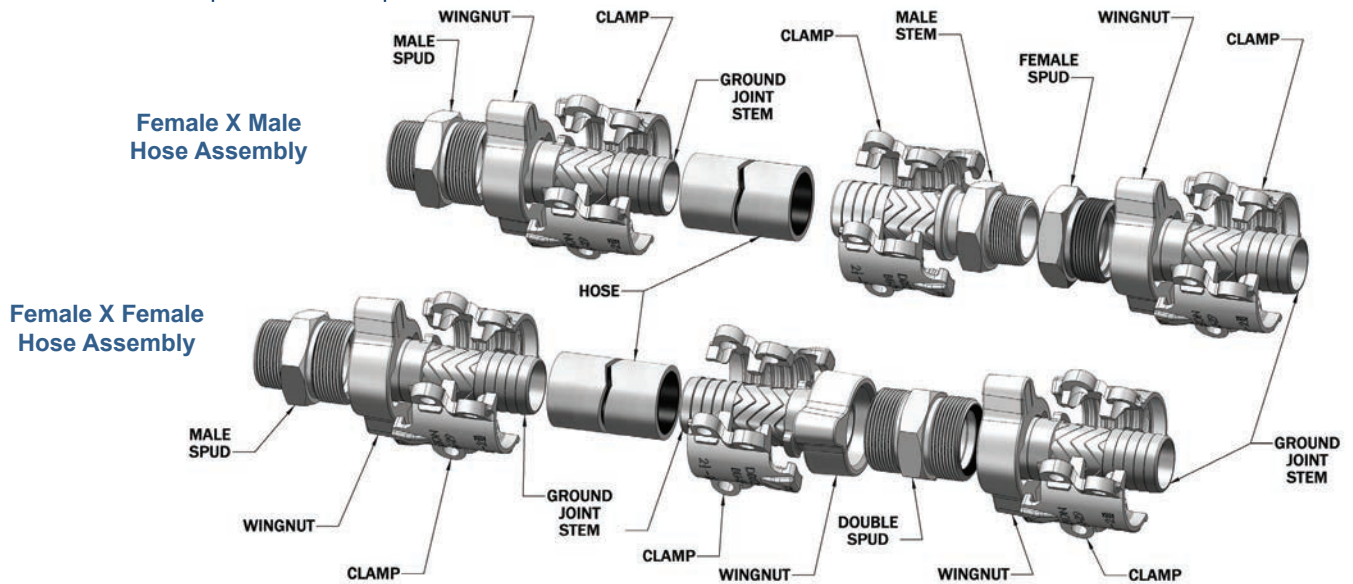

## Boss™ Technical Information

Boss™ Couplings Working Pressure Ratings						
Size (inch)	Air		Water		Steam	
	PSI	MPa	PSI	MPa	PSI	MPa
¼ to 2	600	4.1	600	4.1	250	1.7
2½ and 3	450	3.1	450	3.1	250	1.7
4 and 6	250	1.7	250	1.7	250	1.7

	¼" to 1" include	1½" to 6" include
Stems	Plated Steel	Plated Malleable Iron Through 100mm Tubular Steel - 150mm
Spuds	Plated Steel	Plated Malleable Iron
Wing Nuts	Plated Malleable Iron	Plated Malleable Iron

### GROUND JOINT Positive Metal-to-Polymer Seal

- A leakproof seal is formed when the metal head of the stem makes contact with the patented polymer seat in the spud
- The non-metallic polymer seat resists most chemicals found in manufacturing facilities
- Recommended for steam service up to 230°C (446°F)
- Easy to seal
- Plated steel and/or malleable iron
- Use with Dixon™ Boss™ Clamps in this catalogue

### Washer Type

- A Klinger® washer is inserted between the stem and spud
- A leak proof seal is formed by rotating the wing nut and hammering it tight
- Plated steel and/or malleable iron

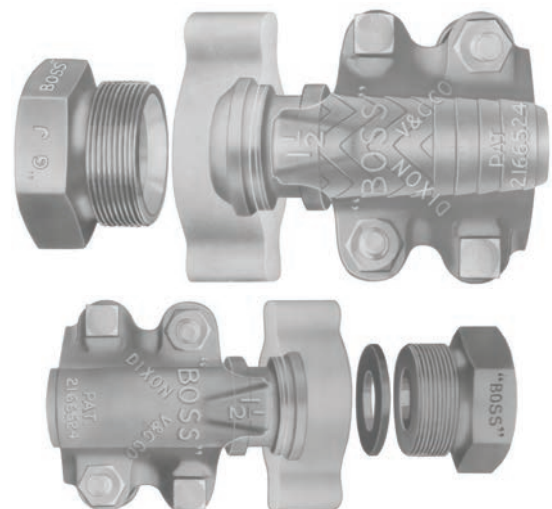

**Warning:** Worn-out hose couplings can be dangerous. They should be checked regularly and replaced when necessary. Each coupling user should review applications and add safety devices where indicated.

## Bolt Tightening Sequence for Dixon™ Boss™ Clamps

### Notes:

1. The correct size Boss™ clamp must be used.
2. Bolts in Boss™ clamps are designed to bend as they are tightened. This allows the clamp to conform to the hose outside diameter.
3. Always tighten bolts to their specified torque value. This torque value can be found on the pages 109-110.
4. Periodic re-tightening of bolts is required due to Cold Flow phenomenon present in all rubber hoses.
5. Boss™ Clamps are for single use only! Once removed they are to be discarded.

## 2-Bolt Dixon™ Boss™ Clamp Bolt Tightening Sequence

### Using a torque wrench, begin tightening the bolts as follows:

- a) First bolt (nut facing assembler) 1 full turn.
- b) Second bolt (opposite first bolt) 1 full turn.
- c) Repeat procedure "a" and "b" until both bolts have reached the recommended torque.
- d) Remove assembly from vise.

## 4-Bolt Dixon™ Boss™ Clamp Bolt Tightening Sequence

### Using a torque wrench, begin tightening the bolts as follows:

- a) Back bolt (bolt with nut facing assembler that is furthest away from gripping finger) 1 full turn.
- b) Front bolt (bolt with nut facing assembler that is closest to gripping finger) 1 full turn.
- c) Snug by hand (if bolts are loose) nuts on opposite side of bolts just torqued.
- d) Opposite side back bolt (bolt with nut facing assembler furthest away from gripping finger) 1 full turn.
- e) Opposite side front bolt (bolt with nut facing assembler closest to gripping finger) 1 full turn.
- f) Snug by hand (if bolts are loose) nuts on opposite side of bolts just torqued.
- g) Repeat above procedure "a" through "f" until all of the bolts have reached the recommended torque.
- h) Remove assembly from vise.

## 6-Bolt Dixon™ Boss™ Clamp Bolt Tightening Sequence

### Using a torque wrench, begin tightening the bolts as follows:

- a) Back bolt (bolt with nut facing assembler that is furthest away from gripping finger) having "X" near it one full turn.
- b) Front bolt (bolt with nut facing assembler that is closest to gripping finger) of same segment one full turn.
- c) Moving to clamp segment to the left of the one just tightened, snug bolts by hand (if bolts are loose).
- d) Back bolt to one full turn.
- e) Front bolt one full turn.
- f) Moving to clamp segment to the left of the one just tightened, snug bolts by hand (if bolts are loose).
- g) Back bolt one full turn.
- h) Front bolt one full turn.
- i) Repeat above procedure "a" through "h" until all of the bolts have reached the recommended torque.
- j) Remove assembly from vise.



## Crimped Air King™ Recommendation Guide

Hose Size ID (inch)	Crimped Length	Part No.	Fractional Hose OD (inch)	Swage Die Sizes (inch)	Die Part No.	Crimp Diameter	% Reduction
½	1¼	AM1WF and RAMWF	54/64	1-3/16 x 29/32	1&3/16D4	0.906	18.3
			55/64	1-3/16 x 15/16	1&3/16D5	0.937	13.2
			56/64	1-3/16 x 15/16	1&3/16D5	0.968	16.9
			57/64	1-3/16 x 31/32	1&3/16D3	0.968	12.1
			58/64	1-3/16 x 31/32	1&3/16D3	1.000	15.5
			59/64	1-3/16 x 1	1&3/16D	1.000	11.1
			60/64	1-3/16 x 1	1&3/16D	1.031	14.4
			61/64	1-3/16 x 1	1&3/16D	1.031	17.2
			62/64	1-3/16 x 1-1/32	1&3/16D2	1.031	13.4
			63/64	1-3/16 x 1-1/32	1&3/16D2	1.031	16.1
			1	1-3/16 x 1-1/16	1&3/16D1	1.062	12.7
			1-1/64	1-3/16 x 1-1/16	1&3/16D1	1.062	15.3
¾	1¼	AM6WF and RAM6WF	1-4/64	1½ x 1-5/32	1&1/2D6	1.156	13.4
			1-5/64	1½ x 1-5/32	1&1/2D6	1.187	17.3
			1-6/64	1½ x 1-3/16	1&1/2D7	1.187	11.9
			1-7/64	1½ x 1-3/16	1&1/2D7	1.218	15.8
			1-8/64	1½ x 1-3/16	1&1/2D7	1.218	11.2
			1-9/64	1½ x 1-7/32	1&1/2D5	1.250	14.6
			1-10/64	1½ x 1-7/32	1&1/2D5	1.250	17.5
			1-11/64	1½ x 1¼	1&1/2D4	1.250	13.0
			1-12/64	1½ x 1¼	1&1/2D4	1.281	16.2
			1-13/64	1½ x 1-9/32	1&1/2D3	1.281	12.3
			1-14/64	1½ x 1-9/32	1&1/2D3	1.281	15.1
			1-15/64	1½ x 1-9/32	1&1/2D3	1.281	11.5
			1-16/64	1½ x 1-5/16	1&1/2D2	1.312	14.4
			1-17/64	1½ x 1-5/16	1&1/2D2	1.312	16.9
			1-18/64	1½ x 1-11/32	1&1/2D	1.343	13.5
			1-19/64	1½ x 1-11/32	1&1/2D	1.343	15.9
			1-20/64	1½ x 1¾	1&1/2D1	1.375	12.6
			1-21/64	1½ x 1¾	1&1/2D1	1.375	15.0
			1-22/64	1½ x 1-13/32	1&1/2D8	1.406	12.1
			1	1½	AM11WF-1	1-18/64	1-11/16 x 1¾
1-19/64	1-11/16 x 1¾	1&11/16D4				1.375	20.5
1-20/64	1-11/16 x 1-13/32	1&11/16D5				1.406	15.0
1-21/64	1-11/16 x 1-13/32	1&11/16D5				1.406	18.6
1-22/64	1-11/16 x 1-7/16	1&11/16D8				1.437	13.7
1-23/64	1-11/16 x 1-7/16	1&11/16D8				1.437	17.5
1-24/64	1-11/16 x 1-15/32	1&11/16D6				1.468	12.8
1-25/64	1-11/16 x 1-15/32	1&11/16D6				1.468	16.1
1-26/64	1-11/16 x 1-15/32	1&11/16D6				1.468	11.5
1-27/64	1-11/16 x 1½	1&11/16D				1.500	14.7
1-28/64	1-11/16 x 1½	1&11/16D				1.500	17.6
1-29/64	1-11/16 x 1-17/32	1&11/16D2				1.531	13.9
1-30/64	1¾ x 1-17/32	1&7/8D8			1.531	16.8	
1-31/64	1¾ x 1-17/32	1&7/8D8			1.562	12.8	
1-32/64	1¾ x 1-9/16	1&7/8D5			1.562	15.4	
1-33/64	1¾ x 1-9/16	1&7/8D5			1.593	12.0	
1-34/64	1¾ x 1-19/32	1&7/8D6			1.593	14.7	
1-35/64	1¾ x 1-19/32	1&7/8D6			1.593	11.1	
1-36/64	1¾ x 1%	1&7/8D7			1.625	13.7	
1-37/64	1¾ x 1%	1&7/8D7			1.625	15.9	
1-38/64	1¾ x 1-21/32	1&7/8D1			1.656	12.9	
1-39/64	1¾ x 1-21/32	1&7/8D1			1.656	15.1	
1-40/64	1¾ x 1-11/16	1&7/8D			1.687	12.4	
1-41/64	1¾ x 1-11/16	1&7/8D			1.687	14.5	
1-42/64	1¾ x 1-23/32	1&7/8D2	1.718	11.8			
1-43/64	1¾ x 1-23/32	1&7/8D2	1.718	14.0			
1-44/64	1¾ x 1-23/32	1&7/8D2	1.718	11.3			
1-45/64	1¾ x 1¾	1&7/8D4	1.750	13.3			
1-46/64	1¾ x 1¾	1&7/8D4	1.750	15.1			

Please note that the chart is to be used only as a guide and not as a steadfast rule for every coupling application. In some instances, alternative dies and crimped dimensions must be employed. Hoses, as well as couplings, react differently during crimping. This is due to the fact that there are variances in hose constructions for hose with similar dimensions. Some variables are: textile braid vs. wire braid, hardwall vs. softwall, presence or lack of internal spiral wire as well as differences in hose covers. In addition, the outer diameter of the hose tends to fluctuate from end to end and production lot to production lot. With this in mind, we suggest that you measure the hose OD and maintain accurate records for each coupling application.

Note: Multiply Decimal by 25.4 for OD mm (eg: 0.844 x 25.4 = 21.43mm)



## Crimped Dix-Lock™ and Dual-Lock Recommendation Guide

Please note that the chart below is to be used only as a guide and not as a steadfast rule for every coupling application. In some instances, alternative dies and crimped dimensions must be employed. Hoses, as well as couplings, react differently during crimping. This is due to the fact that there are variances in hose constructions for hose with similar dimensions. Some variables are: textile braid vs. wire braid, hardwall vs. softwall, presence or lack of internal spiral wire as well as differences in hose covers. In addition, the outer diameter of the hose tends to fluctuate from end to end and production lot to production lot. With this in mind, we suggest that you measure the hose OD and maintain accurate records for each coupling application.

Hose ID (inch)	Measured Hose OD		Crimp Length	Dix-Lock™ Crimp OD ± .005	Crimp Length	Dual-Lock Crimp OD ± .005
	Fractional	Decimal				
				<b>Part No. QM3WF, QB3WF, QM22WF, QB22WF, QM33WF, QB33WF</b>		<b>Part No. PHL8WF</b>
½	54/64"	0.844	1½	0.968	1¼	0.968
½	55/64"	0.859	1½	0.968	1¼	0.968
½	56/64"	0.875	1½	0.968	1¼	0.968
½	57/64"	0.891	1½	1.000	1¼	1.000
½	58/64"	0.906	1½	1.000	1¼	1.000
½	59/64"	0.922	1½	1.031	1¼	1.031
½	60/64"	0.938	1½	1.031	1¼	1.031
½	61/64"	0.953	1½	1.062	1¼	1.062
½	62/64"	0.969	1½	1.062	1¼	1.062
½	63/64"	0.984	1½	1.062	1¼	1.062
½	1"	1.000	1½	1.093	1¼	1.093
½	1-1/64"	1.016	1½	1.093	1¼	1.093
½	1-2/64"	1.031	1½	1.093	1¼	1.093
				<b>Part No. QM4WF, QB4WF, QM23WF, QB23WF, QM44WF, QB44WF</b>		<b>Part No. PHL12WF</b>
¾	1-10/64"	1.156	1¼	1.218	1¼	1.218
¾	1-11/64"	1.172	1¼	1.218	1¼	1.218
¾	1-12/64"	1.188	1¼	1.218	1¼	1.218
¾	1-13/64"	1.203	1¼	1.250	1¼	1.250
¾	1-14/64"	1.219	1¼	1.250	1¼	1.250
¾	1-15/64"	1.234	1¼	1.281	1¼	1.281
¾	1-16/64"	1.250	1¼	1.281	1¼	1.281
¾	1-17/64"	1.266	1¼	1.281	1¼	1.281
¾	1-18/64"	1.281	1¼	1.312	1¼	1.312
¾	1-19/64"	1.297	1¼	1.312	1¼	1.312
¾	1-20/64"	1.313	1¼	1.343	1¼	1.343
¾	1-21/64"	1.328	1¼	1.343	1¼	1.343
¾	1-22/64"	1.344	1¼	1.375	1¼	1.375

Note: Multiply Decimal by 25.4 for OD mm (eg; 0.906 x 25.4 = 23.01mm)

Dixon™'s couplings and retention devices are designed to work safely for their intended use. The selection of the proper hose, coupling and retention devices, and the proper application of the coupling to the hose are of the utmost importance. Users must consider the size, temperature, application, media, pressure, and the hose and coupling manufacturers' recommendations when selecting the proper hose assembly components.

Dixon™ recommends that all hose assemblies be tested in accordance with the Rubber Manufacturers' Association's recommendations and be inspected regularly (before each use), to ensure that they are not damaged or become loose.

Where safety devices are integral to the coupling, they must be working and utilized. The use of supplementary safety devices, such as safety clips and King™ safety cables, are recommended. If any problem is detected, couplings must be removed from service immediately.

Dixon™ is available to consult, train, and recommend the proper selection and application of all fittings we sell. We strongly recommend that distributors, and end users make use of Dixon's testing and recommendations services.

## Hydraulic Coupling Profile Chart

### Dixon™ Straight Thru Fittings: refer to pages 238-242

Perfecting E Series  
Parker ST  
Hansen ST

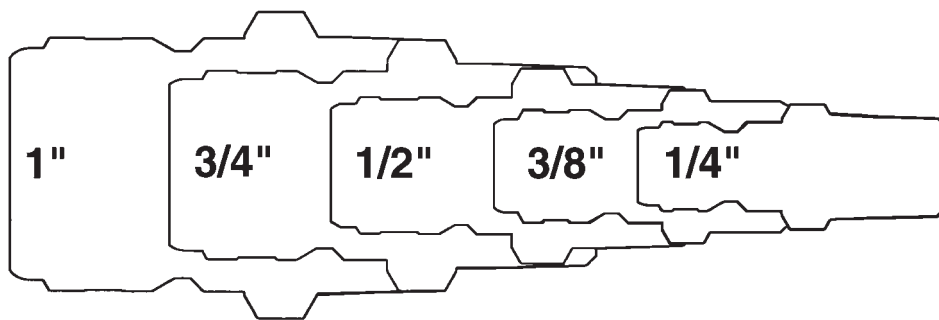

### Dixon™ Industrial Fittings: refer to pages 187-191

ISO 7241-B  
Perfecting H Series  
Hansen HK  
Aeroquip FD45  
Parker 60

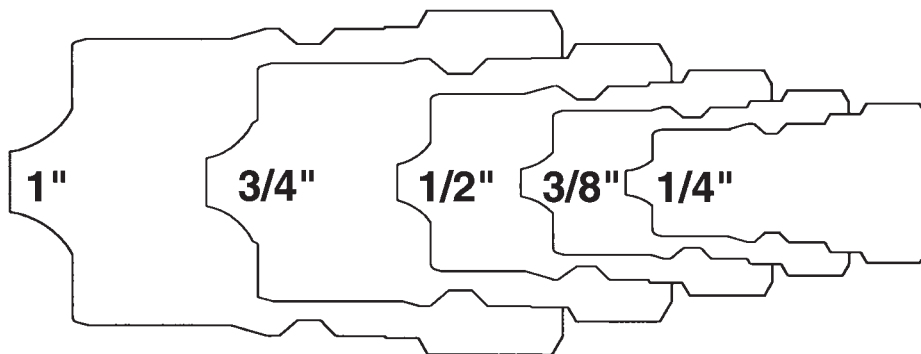

### Dixon™ Agricultural Fittings: refer to pages 230-232

Perfecting AG Series  
Aeroquip FD76  
Parker/Pioneer 4000  
Safeway S20

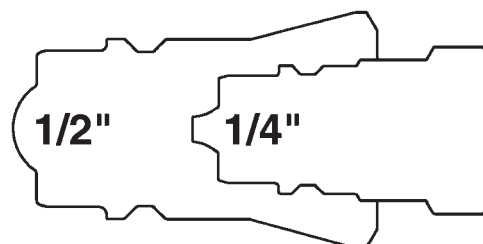

### Dixon™ 5600 Series: refer to pages 197-200

ISO 7241-A  
Perfecting K Series  
Aeroquip 5600  
Parker 6600

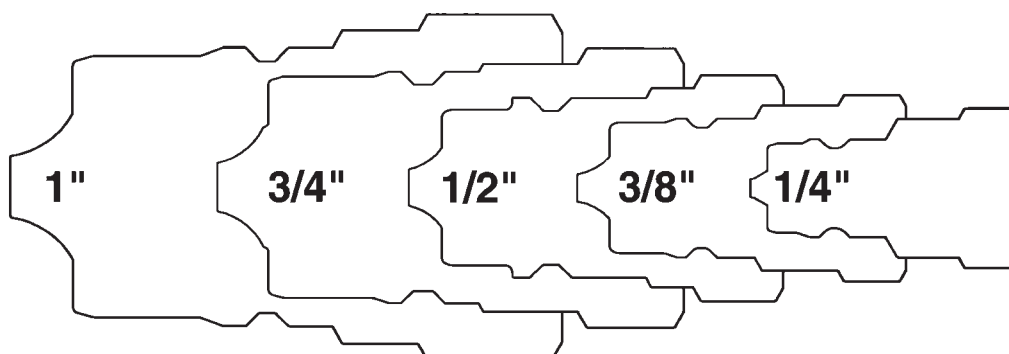

## Hydraulic Coupling Profile Chart

### Dixon™ 7800 Series: refer to pages 201-204

Perfecting W Series  
 Aeroquip 5100  
 Parker 6100

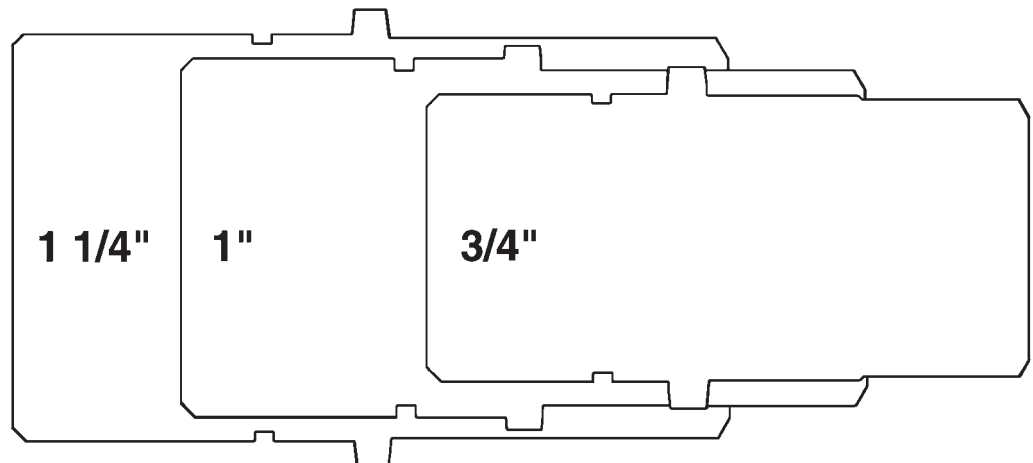

### Dixon™ VH Series: refer to pages 243-253

Perfecting V Series  
 Snap-tite H  
 Faster TNV

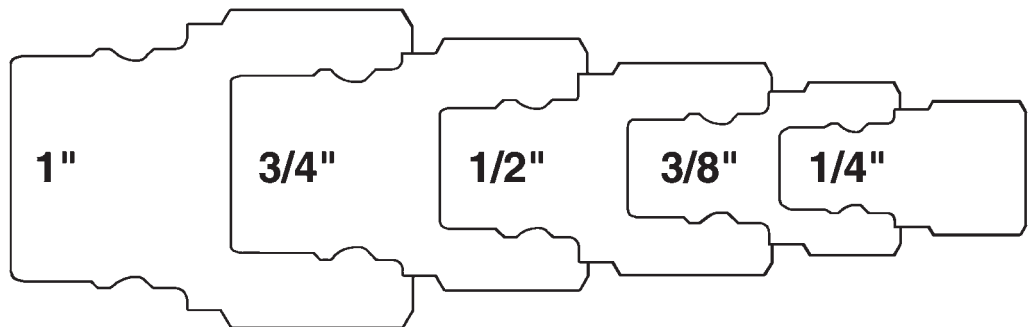

### Dixon™ Flush Face Fittings: refer to pages 216-222

Perfecting HT Series  
 Aeroquip FD49  
 HTMA Parker FF

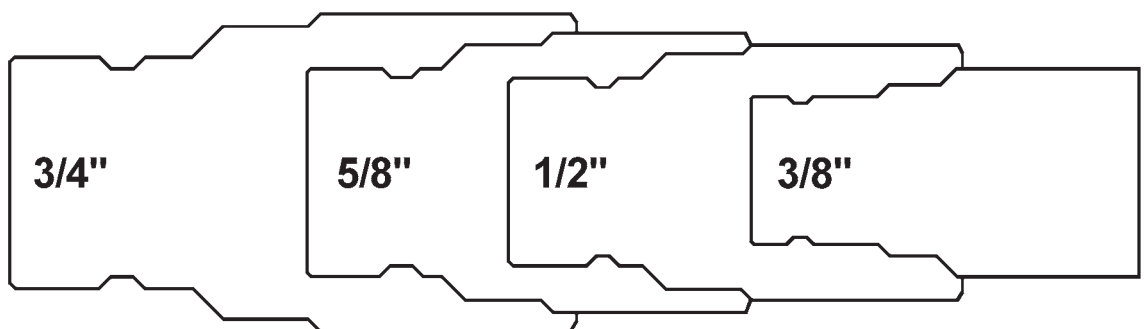

### Dixon™ 3000 Series: refer to page 233-234

Perfecting T Series  
 Parker 3000  
 Enerpac C604

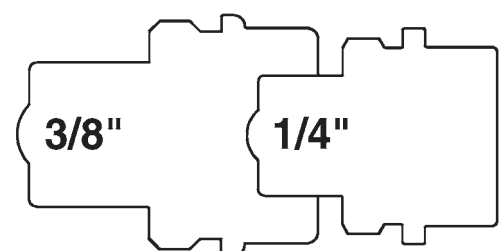

J

## Pneumatic Coupling Profiles

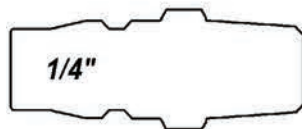
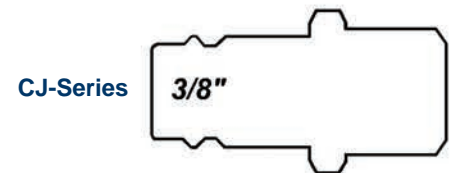
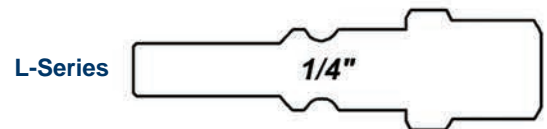
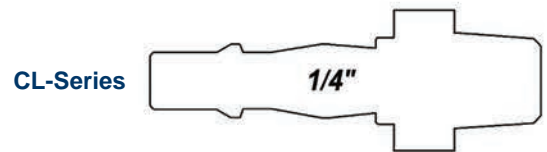

NK-Series: refer to pages 179-180

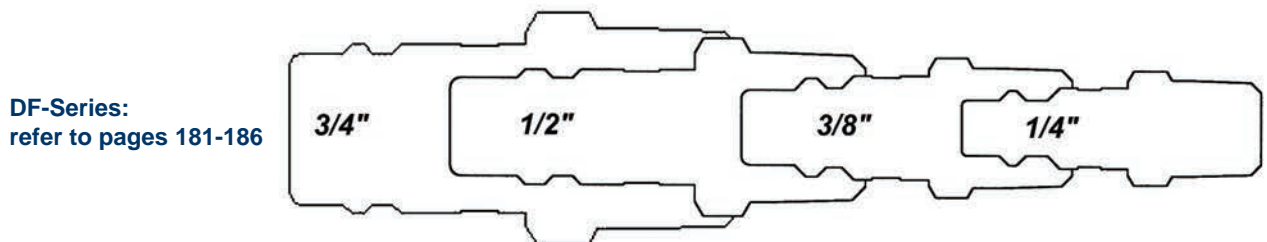
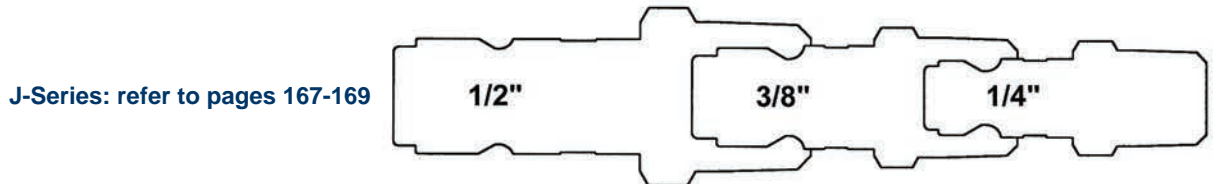
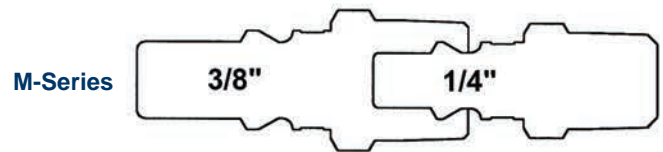
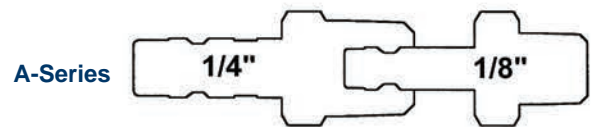

## Fluid Compatibility Guide



The following chart is intended only as a guide in selecting various elastomers and metals for use with fluids to be conveyed through Dixon Quick Disconnect Couplings. This list does not guarantee suitability for a particular application. Final selection is dependent upon operating pressure, fluid and ambient temperature, concentration of media, duration of exposure, environmental conditions, and frequency of connect and disconnect.

Material	Prefix Code	Trade Name	Range °C	Range °F
Buna-N	Standard	Nitrile	-40°C to 121°C	-40°F to 250°F
Buna-N (MIL-H-5606 Fluids)	M-	Nitrile	-54°C to 135°C	-65°F to 275°F
Buna-N (Hydrocarbon Fuels)	JF-	Nitrile	-54°C to 71°C	-65°F to 160°F
Fluorocarbon Rubber	F-	FKM	-29°C to 204°C	-20°F to 400°F
Ethyl Propylene Diene Monomer	P-	EPDM	-54°C to 149°C	-65°F to 300°F
Neoprene	E-	Neoprene	-43°C to 149°C	-45°F to 300°F
Silicone	S-	Silicone	-73°C to 177°C	-100°F to 350°F
Fluorosilicone (FVMQ)	FS-	Silastic®	-60°C to 180°C	-76°F to 376°F
Urethane	U-	Urethane	-40°C to 82°C	-40°F to 180°F
Polyurethane	UP-	Polyurethane	-54°C to 100°C	-65°F to 212°F
PTFE Encapsulated Silicone	TS-	TES	-73°C to 204°C	-100°F to 400°F
PTFE Encapsulated Fluorocarbon	TF-	TEF	-73°C to 204°C	-100°F to 400°F
Perfluoroelastomer (Compound 1)	K4-	Kalrez® 4079	-20°C to 316°C	-4°F to 600°F
Perfluoroelastomer (Compound 2)	K6-	Kalrez® 6375	-20°C to 275°C	-4°F to 525°F
Perfluoroelastomer (Compound 3)	K7-	Kalrez® 7075	-20°C to 327°C	-4°F to 620°F
Fluoroelastomer	H-	Aflas®	-5°C to 204°C	23°F to 400°F

Media Name	Suggested Seal	Media Name	Suggested Seal	Media Name	Suggested Seal
Acetic Anhydride	P-	Freon, General	E-	Mineral Spirits	Standard
Acetone	P-	Ferric Hydroxide	Standard	Nickel Acetate	P-
Acetylene	Standard	Formaldehyde (50%)	P-	Nickel Suphate	P-
Air (To 93°C (200°F))	Standard	Fuel Oils, General	Standard	Nitrogen, Gas	Standard
Air (Above 93°C (200°F))	F-	Gasoline	Standard	Nitrous Oxide	Standard
Alcohol, Ethyl	P-	Glycerine (Glycerol)	Standard	Octane	F-
Alcohol, Methyl	Standard	Glycols	P-	Oleum Spirits	Standard
Alkalies, General	Standard	Helium	Standard	OS45 and OS45-1	F-
Ammonia, Aqueous	P-	Heptane	Standard	Oxygen, Non-Breathing	F-
Ammonia, Gas	P-	Hexane	Standard	Paint Thinner	F-
Ammonia, Anhydrous	P-	Hydraulic Oil, Aircraft	Standard	Paraffin	Standard
Ammonia, Hydroxide	P-	Hydraulic Oil, Petroleum	Standard	Peanut Oil	Standard
Aroclor	F-	Hydraulic Oil, Phosphate	P-	Pentane	Standard
Benzene (Benzol)	F-	Hydrogen Gas	Standard	Perchloroethylene	F-
Bleach Solutions	P-	Hydrolube	Standard	Phosphoric Acid (100%)	P-
Brake Fluid, Non-Petro	P-	Isobutyl Alcohol	P-	Photographic Solutions	P-
Bromine Gas	F-	Isopropyl Alcohol	F-	Potassium Acetate	P-
Butane	Standard	Jet Fuel (to 160°F)	JF-	Propane	Standard
Butyl Alcohol	Standard	Jet Fuel (above 160°F)	F-	Propylene	F-
Carbon Dioxide, Dry	Standard	Kerosene	Standard	Propylene Glycol	Standard
Carbon Dioxide, Wet	Standard	Lindol	P-	Silicone Oil	Nitrile
Carbon Monoxide	Standard	LP Gas	Standard	Steam, General Service	H-
Carbon Tetrachloride	F-	Magnesium Hydroxide	F-	Stoddard Solvent	Standard
Cellulube	P-	Methane	Standard	Sulphuric Acid (100%)	F-
Creosote	F-	Methanol	Standard	Toluene	F-
Crude Oil	F-	Methyl Bromide	F-	Transmission Fluid (A)	Standard
Cutting Oil	Standard	Methyl Ethyl Ketone (MEK)	P-	Trichloroethylene	F-
Diesel Fuel	Standard	MIL-F-81912 (JP-9)	P-	Turpentine	Standard
Diester Lubricants	F-	MIL-H-5606	M1-	Vegetable Oil	Standard
Ethane	Standard	MIL-H-5806	Standard	Water	Standard
Ethanol	Standard	MIL-H-6083	Standard	Water, Distilled	Standard
Ethyl Chloride	Standard	MIL-H-7083	Standard	Water, Dionized	Standard
Ethylene Glycol	P-	Mineral Oils	Standard	Water, Sea	P-

## King Crimp™ Recommendation Guide

Hose	Cam & Groove Coupler	Cam & Groove Adaptor	KC Nipple	Ferrule	Hose OD		Hose OD	Crimp Diameter	Hose OD		Hose OD	Crimp Diameter		
					From (inch)	To (inch)			From (mm)	To (mm)				
1" Hose ID Imperial Hose = 25.4mm	100-C-AL 100-C-BR 100-C-SS RC100EZCR G100-C-ALCR G100-C-BRCR G100-C-SSCR AL100C BR100C SS100C	100-E-AL 100-E-BR 100-E-SS G100-E-ALCR G100-E-BRCR G100-E-SSCR AL100E BR100E SS100E	ST10CS STC10CS STC10ACS STV10CS STB10CS	CF100-1XX CS100-1XX	1 <sup>13</sup> / <sub>64</sub>	1 <sup>16</sup> / <sub>64</sub>	1 <sup>13</sup> / <sub>64</sub>	32.16	30.56	31.75	30.56	32.47		
							1 <sup>7</sup> / <sub>32</sub>	32.46			30.96	32.78		
							1 <sup>15</sup> / <sub>64</sub>	32.77			31.35	33.09		
							1 <sup>16</sup> / <sub>64</sub>	33.10			31.75	33.39		
				CF100-2XX CS100-2XX	1 <sup>17</sup> / <sub>64</sub>	1 <sup>20</sup> / <sub>64</sub>	1 <sup>17</sup> / <sub>64</sub>	33.45	32.15	33.34	32.15	33.77	32.15	33.77
							1 <sup>18</sup> / <sub>64</sub>	33.76			32.54	34.08		
							1 <sup>19</sup> / <sub>64</sub>	34.09			32.94	34.39		
							1 <sup>20</sup> / <sub>64</sub>	34.39			33.34	34.70		
				CF100-3XX CS100-3XX	1 <sup>21</sup> / <sub>64</sub>	1 <sup>24</sup> / <sub>64</sub>	1 <sup>21</sup> / <sub>64</sub>	34.70	33.73	34.93	33.73	35.01	33.73	35.01
							1 <sup>22</sup> / <sub>64</sub>	35.00			34.13	35.32		
							1 <sup>23</sup> / <sub>64</sub>	35.31			34.53	35.63		
							1 <sup>24</sup> / <sub>64</sub>	35.64			36.51	35.94		
			CF100-4XX CS100-4XX	1 <sup>25</sup> / <sub>64</sub>	1 <sup>28</sup> / <sub>64</sub>	1 <sup>25</sup> / <sub>64</sub>	36.04	35.32	36.51	35.32	36.35	35.32	36.35	
						1 <sup>26</sup> / <sub>64</sub>	36.35			35.72	36.66			
						1 <sup>27</sup> / <sub>64</sub>	36.65			36.12	36.98			
						1 <sup>28</sup> / <sub>64</sub>	36.98			36.51	37.29			
			CF100-6XX CS100-6XX	1 <sup>33</sup> / <sub>64</sub>	1 <sup>36</sup> / <sub>64</sub>	1 <sup>29</sup> / <sub>64</sub>	37.29	38.50	39.69	36.91	37.60	36.91	37.60	
						1 <sup>30</sup> / <sub>64</sub>	37.59			37.31	37.92			
						1 <sup>31</sup> / <sub>64</sub>	37.92			37.70	38.23			
						1 <sup>32</sup> / <sub>64</sub>	38.23			38.10	38.54			
			CF100-7XX CS100-7XX	1 <sup>37</sup> / <sub>64</sub>	1 <sup>40</sup> / <sub>64</sub>	1 <sup>37</sup> / <sub>64</sub>	39.80	40.08	41.28	40.08	40.11	40.08	40.11	
						1 <sup>38</sup> / <sub>64</sub>	40.11			40.48	40.42			
						1 <sup>39</sup> / <sub>64</sub>	40.41			40.88	40.74			
						1 <sup>40</sup> / <sub>64</sub>	40.74			41.28	41.05			
			CF100-8XX CS100-8XX	1 <sup>41</sup> / <sub>64</sub>	1 <sup>44</sup> / <sub>64</sub>	1 <sup>41</sup> / <sub>64</sub>	41.05	41.67	42.86	41.67	41.36	41.67	41.36	
						1 <sup>42</sup> / <sub>64</sub>	41.35			42.07	41.68			
						1 <sup>43</sup> / <sub>64</sub>	41.68			42.47	41.99			
						1 <sup>44</sup> / <sub>64</sub>	41.99			42.86	42.31			
			CF100-9XX CS100-9XX	1 <sup>44</sup> / <sub>64</sub>	1 <sup>47</sup> / <sub>64</sub>	1 <sup>45</sup> / <sub>64</sub>	42.29	42.86	44.05	42.86	42.62	42.86	42.62	
						1 <sup>46</sup> / <sub>64</sub>	42.62			43.66	42.93			
						1 <sup>47</sup> / <sub>64</sub>	42.93			44.05	43.25			
						1 <sup>48</sup> / <sub>64</sub>	43.26			44.45	43.56			
			CF100-10XX CS100-10XX	1 <sup>48</sup> / <sub>64</sub>	1 <sup>51</sup> / <sub>64</sub>	1 <sup>49</sup> / <sub>64</sub>	43.56	44.45	45.64	44.45	43.87	44.45	43.87	
						1 <sup>50</sup> / <sub>64</sub>	43.87			45.24	44.19			
						1 <sup>51</sup> / <sub>64</sub>	44.20			45.64	44.50			
						1 <sup>52</sup> / <sub>64</sub>	44.50			46.04	44.81			

Hose	Cam & Groove Coupler	Cam & Groove Adaptor	KC Nipple	Sleeve & Ferrule	Hose OD		Hose OD	Crimp Diameter	Hose OD		Hose OD	Crimp Diameter		
					From (inch)	To (inch)			From (mm)	To (mm)				
1 1/4" Hose ID Imperial Hose = 31.75mm	RC125EZCR	---	STC15CS RST15CS STV15CS RSTV15CS STB15CS RSTB15CS	CS125-3xx CF125-3xx	1 <sup>41</sup> / <sub>64</sub>	1 <sup>44</sup> / <sub>64</sub>	1 <sup>41</sup> / <sub>64</sub>	1.679	41.672	42.863	41.672	42.636		
							1 <sup>42</sup> / <sub>64</sub>	1.691			42.069	42.95		
							1 <sup>43</sup> / <sub>64</sub>	1.703			42.466	43.263		
							1 <sup>44</sup> / <sub>64</sub>	1.716			42.863	43.577		
				CS125-4xx CF125-4xx	1 <sup>45</sup> / <sub>64</sub>	1 <sup>48</sup> / <sub>64</sub>	1 <sup>45</sup> / <sub>64</sub>	1.728	43.259	44.450	43.259	43.89	43.259	43.89
							1 <sup>46</sup> / <sub>64</sub>	1.74			43.656	44.204		
							1 <sup>47</sup> / <sub>64</sub>	1.753			44.053	44.517		
							1 <sup>48</sup> / <sub>64</sub>	1.765			44.450	44.831		
				CS125-5xx CF125-5xx	1 <sup>49</sup> / <sub>64</sub>	1 <sup>52</sup> / <sub>64</sub>	1 <sup>49</sup> / <sub>64</sub>	1.777	44.847	46.038	44.847	45.145	44.847	45.145
							1 <sup>50</sup> / <sub>64</sub>	1.79			45.244	45.458		
							1 <sup>51</sup> / <sub>64</sub>	1.802			45.641	45.772		
							1 <sup>52</sup> / <sub>64</sub>	1.814			46.038	46.085		
				CS125-6xx CF125-6xx	1 <sup>53</sup> / <sub>64</sub>	1 <sup>56</sup> / <sub>64</sub>	1 <sup>53</sup> / <sub>64</sub>	1.827	46.434	47.625	46.434	46.399	46.434	46.399
							1 <sup>54</sup> / <sub>64</sub>	1.839			46.831	46.712		
							1 <sup>55</sup> / <sub>64</sub>	1.851			47.228	47.026		
							1 <sup>56</sup> / <sub>64</sub>	1.864			47.625	47.339		

Note: Crimp values are in millimeters (± 0.13mm)



## King Crimp™ Recommendation Guide

Hose	Cam & Groove Coupler	Cam & Groove Adaptor	KC Nipple	Ferrule	Hose OD		Hose OD	Crimp Diameter	Hose OD		Hose OD	Crimp Diameter
					From (inch)	To (inch)			From (mm)	To (mm)		
1.5" Hose ID Imperial Hose = 38.1mm	150-C-AL 150-C-BR 150-C-SS C150EZCR G150-C-ALCR G150-C-BRCR G150-C-SSCR	150-E-AL 150-E-BR 150-E-SS G150-E-ALCR G150-E-BRCR G150-E-SSCR	STC20CS RST20CS STV20CS RSTV20CS STB20CS RSTB20CS FST20CS RFST20CS	CS150-1xx CF150-1xx	1 <sup>41</sup> / <sub>64</sub>	1 <sup>44</sup> / <sub>64</sub>	1 <sup>41</sup> / <sub>64</sub>	1.726	41.672	42.863	41.672	43.842
							1 <sup>21</sup> / <sub>32</sub>	1.738			42.069	44.136
							1 <sup>43</sup> / <sub>64</sub>	1.749			42.466	44.429
							1 <sup>11</sup> / <sub>16</sub>	1.761			42.863	44.723
				CS150-2xx CF150-2xx	1 <sup>45</sup> / <sub>64</sub>	1 <sup>48</sup> / <sub>64</sub>	1 <sup>45</sup> / <sub>64</sub>	1.778	43.259	44.450	43.259	45.172
							1 <sup>23</sup> / <sub>32</sub>	1.79			43.656	45.477
							1 <sup>47</sup> / <sub>64</sub>	1.802			44.053	45.783
							1 <sup>3</sup> / <sub>4</sub>	1.815			44.450	46.088
				CS150-3xx CF150-3xx	1 <sup>49</sup> / <sub>64</sub>	1 <sup>52</sup> / <sub>64</sub>	1 <sup>49</sup> / <sub>64</sub>	1.829	44.847	46.038	44.847	46.461
							1 <sup>25</sup> / <sub>32</sub>	1.841			45.244	46.771
							1 <sup>51</sup> / <sub>64</sub>	1.854			45.641	47.08
							1 <sup>13</sup> / <sub>16</sub>	1.866			46.038	47.39
				CS150-4xx CF150-4xx	1 <sup>53</sup> / <sub>64</sub>	1 <sup>56</sup> / <sub>64</sub>	1 <sup>53</sup> / <sub>64</sub>	1.878	46.434	47.625	46.434	47.7
							1 <sup>27</sup> / <sub>32</sub>	1.89			46.831	48.009
							1 <sup>55</sup> / <sub>64</sub>	1.902			47.228	48.319
							1 <sup>7</sup> / <sub>8</sub>	1.915			47.625	48.628
				CS150-5xx CF150-5xx	1 <sup>57</sup> / <sub>64</sub>	1 <sup>60</sup> / <sub>64</sub>	1 <sup>57</sup> / <sub>64</sub>	1.931	48.022	49.213	48.022	49.037
							1 <sup>29</sup> / <sub>32</sub>	1.943			48.419	49.351
							1 <sup>59</sup> / <sub>64</sub>	1.955			48.816	49.664
							1 <sup>15</sup> / <sub>16</sub>	1.968			49.213	49.978
				CS150-6xx CF150-6xx	1 <sup>61</sup> / <sub>64</sub>	2	1 <sup>61</sup> / <sub>64</sub>	1.98	49.609	50.800	49.609	50.291
							1 <sup>31</sup> / <sub>32</sub>	1.992			50.006	50.605
							1 <sup>63</sup> / <sub>64</sub>	2.005			50.403	50.918
							2	2.017			50.800	51.232
				CS150-7xx CF150-7xx	2 <sup>1</sup> / <sub>64</sub>	2 <sup>4</sup> / <sub>64</sub>	2 <sup>1</sup> / <sub>64</sub>	2.029	51.197	52.388	51.197	51.545
							2 <sup>1</sup> / <sub>32</sub>	2.042			51.594	51.859
							2 <sup>3</sup> / <sub>64</sub>	2.054			51.991	52.172
							2 <sup>1</sup> / <sub>16</sub>	2.066			52.388	52.486
				CS150-8xx CF150-8xx	2 <sup>5</sup> / <sub>64</sub>	2 <sup>9</sup> / <sub>64</sub>	2 <sup>5</sup> / <sub>64</sub>	2.079	52.784	53.975	52.784	52.799
							2 <sup>3</sup> / <sub>32</sub>	2.091			53.181	53.113
							2 <sup>7</sup> / <sub>64</sub>	2.103			53.578	53.427
							2 <sup>1</sup> / <sub>8</sub>	2.116			53.975	53.74
				CS150-9xx CF150-9xx	2 <sup>9</sup> / <sub>64</sub>	2 <sup>12</sup> / <sub>64</sub>	2 <sup>9</sup> / <sub>64</sub>	2.128	54.372	55.563	54.372	54.054
							2 <sup>5</sup> / <sub>32</sub>	2.14			54.769	54.367
							2 <sup>11</sup> / <sub>64</sub>	2.153			55.166	54.681
							2 <sup>3</sup> / <sub>16</sub>	2.165			55.563	54.994
				CS150-10xx CF150-10xx	2 <sup>13</sup> / <sub>64</sub>	2 <sup>16</sup> / <sub>64</sub>	2 <sup>13</sup> / <sub>64</sub>	2.177	55.959	57.150	55.959	55.308
							2 <sup>7</sup> / <sub>32</sub>	2.19			56.356	55.621
							2 <sup>15</sup> / <sub>64</sub>	2.202			56.753	55.935
							2 <sup>1</sup> / <sub>4</sub>	2.215			57.150	56.248
				CS150-11xx CF150-11xx	2 <sup>17</sup> / <sub>64</sub>	2 <sup>20</sup> / <sub>64</sub>	2 <sup>17</sup> / <sub>64</sub>	2.227	57.547	58.738	57.547	56.562
							2 <sup>9</sup> / <sub>32</sub>	2.239			57.944	56.875
							2 <sup>19</sup> / <sub>64</sub>	2.252			58.341	57.189
							2 <sup>5</sup> / <sub>16</sub>	2.264			58.738	57.502
				CS150-12xx CF150-12xx	2 <sup>21</sup> / <sub>64</sub>	2 <sup>24</sup> / <sub>64</sub>	2 <sup>21</sup> / <sub>64</sub>	2.276	59.134	60.325	59.134	57.816
							2 <sup>11</sup> / <sub>32</sub>	2.289			59.531	58.129
							2 <sup>23</sup> / <sub>64</sub>	2.301			59.928	58.443
							2 <sup>3</sup> / <sub>8</sub>	2.313			60.325	58.757

Note: Crimp values are in millimeters (± 0.13mm)



### King Crimp™ Recommendation Guide

Hose	Cam & Groove Coupler	Cam & Groove Adaptor	KC Nipple	Ferrule	Hose OD		Hose OD	Crimp Diameter	Hose OD		Hose OD	Crimp Diameter
					From (inch)	To (inch)			From (mm)	To (mm)		
2" Hose ID Imperial Hose = 50.8mm	200-C-AL 200-C-BR 200-C-SS RC200EZCR G200-C-ALCR G200-C-BRCR G200-C-SSCR AL200AL BR200BR SS200SS	200-E-AL 200-E-BR 200-E-SS G200-E-ALCR G200-E-BRCR G200-E-SSCR AL200E BR200E SS200E	ST20CS STC20CS STC20ACS STV20CS STB20CS RST20SS RST20ASS RSTV20SS RSTB20ASS RSTB20SS	CF200-1XX CS200-1XX	2 <sup>13</sup> / <sub>64</sub>	2 <sup>16</sup> / <sub>64</sub>	2 <sup>13</sup> / <sub>64</sub>	57.86	55.96	57.15	55.96	58.49
							2 <sup>14</sup> / <sub>64</sub>	58.17			56.36	58.79
							2 <sup>15</sup> / <sub>64</sub>	58.47			56.75	59.10
							2 <sup>16</sup> / <sub>64</sub>	58.80			57.15	59.40
				CF200-2XX CS200-2XX	2 <sup>17</sup> / <sub>64</sub>	2 <sup>20</sup> / <sub>64</sub>	2 <sup>17</sup> / <sub>64</sub>	59.16	57.55	58.74	57.55	59.79
							2 <sup>18</sup> / <sub>64</sub>	59.46			57.94	60.09
							2 <sup>19</sup> / <sub>64</sub>	59.79			58.34	60.40
							2 <sup>20</sup> / <sub>64</sub>	60.10			58.74	60.71
				CF200-3XX CS200-3XX	2 <sup>21</sup> / <sub>64</sub>	2 <sup>24</sup> / <sub>64</sub>	2 <sup>21</sup> / <sub>64</sub>	60.40	59.13	60.33	59.13	61.02
							2 <sup>22</sup> / <sub>64</sub>	60.71			59.53	61.33
							2 <sup>23</sup> / <sub>64</sub>	61.01			59.93	61.64
							2 <sup>24</sup> / <sub>64</sub>	61.34			60.33	61.95
				CF200-4XX CS200-4XX	2 <sup>25</sup> / <sub>64</sub>	2 <sup>28</sup> / <sub>64</sub>	2 <sup>25</sup> / <sub>64</sub>	61.75	60.72	61.91	60.72	62.37
							2 <sup>26</sup> / <sub>64</sub>	62.05			61.12	62.68
							2 <sup>27</sup> / <sub>64</sub>	62.10			61.52	63.00
							2 <sup>28</sup> / <sub>64</sub>	62.69			61.91	63.31
				CF200-5XX CS200-5XX	2 <sup>29</sup> / <sub>64</sub>	2 <sup>32</sup> / <sub>64</sub>	2 <sup>29</sup> / <sub>64</sub>	62.99	62.31	63.50	62.31	63.62
							2 <sup>30</sup> / <sub>64</sub>	63.30			62.71	63.94
							2 <sup>31</sup> / <sub>64</sub>	63.63			63.10	64.25
							2 <sup>32</sup> / <sub>64</sub>	63.93			63.50	64.56
				CF200-6XX CS200-6XX	2 <sup>33</sup> / <sub>64</sub>	2 <sup>36</sup> / <sub>64</sub>	2 <sup>33</sup> / <sub>64</sub>	64.24	63.90	65.09	63.90	64.88
							2 <sup>34</sup> / <sub>64</sub>	64.57			64.29	65.19
							2 <sup>35</sup> / <sub>64</sub>	64.87			64.69	65.50
							2 <sup>36</sup> / <sub>64</sub>	65.18			65.09	65.82
				CF200-7XX CS200-7XX	2 <sup>37</sup> / <sub>64</sub>	2 <sup>40</sup> / <sub>64</sub>	2 <sup>37</sup> / <sub>64</sub>	65.51	65.48	66.68	65.48	66.13
							2 <sup>38</sup> / <sub>64</sub>	65.81			65.88	66.44
							2 <sup>39</sup> / <sub>64</sub>	66.12			66.28	66.76
							2 <sup>40</sup> / <sub>64</sub>	66.45			66.68	67.07
				CF200-8XX CS200-8XX	2 <sup>41</sup> / <sub>64</sub>	2 <sup>44</sup> / <sub>64</sub>	2 <sup>41</sup> / <sub>64</sub>	66.75	67.07	68.26	67.07	67.39
							2 <sup>42</sup> / <sub>64</sub>	67.06			67.47	67.70
							2 <sup>43</sup> / <sub>64</sub>	67.39			67.87	68.01
							2 <sup>44</sup> / <sub>64</sub>	67.69			68.26	68.33
				CF200-9XX CS200-9XX	2 <sup>45</sup> / <sub>64</sub>	2 <sup>48</sup> / <sub>64</sub>	2 <sup>45</sup> / <sub>64</sub>	68.00	68.66	69.85	68.66	68.64
							2 <sup>46</sup> / <sub>64</sub>	68.33			69.06	68.95
							2 <sup>47</sup> / <sub>64</sub>	68.63			69.45	69.27
							2 <sup>48</sup> / <sub>64</sub>	68.96			69.85	69.58
				CF200-10XX CS200-10XX	2 <sup>49</sup> / <sub>64</sub>	2 <sup>52</sup> / <sub>64</sub>	2 <sup>49</sup> / <sub>64</sub>	69.27	70.25	71.44	70.25	69.89
							2 <sup>50</sup> / <sub>64</sub>	69.57			70.64	70.21
							2 <sup>51</sup> / <sub>64</sub>	69.90			71.04	70.52
							2 <sup>52</sup> / <sub>64</sub>	70.21			71.44	70.83
				CF200-11XX CS200-11XX	2 <sup>53</sup> / <sub>64</sub>	2 <sup>56</sup> / <sub>64</sub>	2 <sup>53</sup> / <sub>64</sub>	70.51	71.83	73.03	71.83	71.15
							2 <sup>54</sup> / <sub>64</sub>	70.84			72.23	71.46
							2 <sup>55</sup> / <sub>64</sub>	71.15			72.63	71.78
							2 <sup>56</sup> / <sub>64</sub>	71.45			73.03	72.09
				CF200-12XX CS200-12XX	2 <sup>57</sup> / <sub>64</sub>	2 <sup>60</sup> / <sub>64</sub>	2 <sup>57</sup> / <sub>64</sub>	71.78	73.42	74.61	73.42	72.40
							2 <sup>58</sup> / <sub>64</sub>	72.09			73.82	72.72
							2 <sup>59</sup> / <sub>64</sub>	72.39			74.22	73.03
							2 <sup>60</sup> / <sub>64</sub>	72.72			74.61	73.34

Note: Crimp values are in millimeters (± 0.13mm)



### King Crimp™ Recommendation Guide

Hose	Cam & Groove Coupler	Cam & Groove Adaptor	KC Nipple	Ferrule	Hose OD		Hose OD	Crimp Diameter	Hose OD		Hose OD	Crimp Diameter
					From (inch)	To (inch)			From (mm)	To (mm)		
3" Hose ID Imperial Hose = 76.2mm	300-C-AL 300-C-BR 300-C-SS RC300EZCR G300-C-ALCR G300-C-BRCR G300-C-SSCR AL300AL BR300BR SS300SS	300-E-AL 300-E-BR 300-E-SS G300-E-ALCR G300-E-BRCR G300-E-SSCR AL300E BR300E SS300E	ST30CS STC30CS STC30ACS STV30CS STB30CS RST30SS RST30ASS RSTV30SS RSTB30ASS RSTB30SS	CF300-1XX CS300-1XX	3 <sup>13</sup> / <sub>64</sub>	3 <sup>16</sup> / <sub>64</sub>	3 <sup>13</sup> / <sub>64</sub>	84.66	81.36	82.55	81.36	85.59
							3 <sup>14</sup> / <sub>64</sub>	84.96			81.76	85.90
							3 <sup>15</sup> / <sub>64</sub>	59.87			82.15	86.20
				CF300-2XX CS300-2XX	3 <sup>17</sup> / <sub>64</sub>	3 <sup>20</sup> / <sub>64</sub>	3 <sup>16</sup> / <sub>64</sub>	85.60	82.55	86.51		
							3 <sup>17</sup> / <sub>64</sub>	85.95	82.95	86.89		
							3 <sup>18</sup> / <sub>64</sub>	86.26	83.34	87.20		
				CF300-3XX CS300-3XX	3 <sup>19</sup> / <sub>64</sub>	3 <sup>20</sup> / <sub>64</sub>	3 <sup>19</sup> / <sub>64</sub>	86.59	83.74	87.51		
							3 <sup>20</sup> / <sub>64</sub>	86.89	84.14	87.82		
							3 <sup>21</sup> / <sub>64</sub>	87.20	84.53	88.13		
				CF300-3XX CS300-3XX	3 <sup>21</sup> / <sub>64</sub>	3 <sup>24</sup> / <sub>64</sub>	3 <sup>22</sup> / <sub>64</sub>	87.50	84.93	88.44		
							3 <sup>23</sup> / <sub>64</sub>	87.81	85.33	88.75		
							3 <sup>24</sup> / <sub>64</sub>	88.14	85.73	89.06		
				CF300-4XX CS300-4XX	3 <sup>25</sup> / <sub>64</sub>	3 <sup>28</sup> / <sub>64</sub>	3 <sup>25</sup> / <sub>64</sub>	88.54	86.12	89.48		
							3 <sup>26</sup> / <sub>64</sub>	88.85	86.52	89.80		
							3 <sup>27</sup> / <sub>64</sub>	89.15	86.92	90.11		
				CF300-4XX CS300-4XX	3 <sup>28</sup> / <sub>64</sub>	3 <sup>28</sup> / <sub>64</sub>	3 <sup>28</sup> / <sub>64</sub>	89.48	87.31	90.42		
							3 <sup>29</sup> / <sub>64</sub>	89.79	87.71	90.74		
							3 <sup>30</sup> / <sub>64</sub>	90.09	88.11	91.05		
				CF300-5XX CS300-5XX	3 <sup>29</sup> / <sub>64</sub>	3 <sup>32</sup> / <sub>64</sub>	3 <sup>31</sup> / <sub>64</sub>	90.42	88.90	91.36		
							3 <sup>32</sup> / <sub>64</sub>	90.73	88.90	91.68		
							3 <sup>33</sup> / <sub>64</sub>	91.03	89.30	91.99		
				CF300-6XX CS300-6XX	3 <sup>33</sup> / <sub>64</sub>	3 <sup>36</sup> / <sub>64</sub>	3 <sup>34</sup> / <sub>64</sub>	91.36	89.30	92.30		
							3 <sup>35</sup> / <sub>64</sub>	91.67	90.09	92.62		
							3 <sup>36</sup> / <sub>64</sub>	91.97	90.49	92.93		
				CF300-7XX CS300-7XX	3 <sup>37</sup> / <sub>64</sub>	3 <sup>40</sup> / <sub>64</sub>	3 <sup>37</sup> / <sub>64</sub>	92.30	90.88	93.24		
							3 <sup>38</sup> / <sub>64</sub>	92.61	91.28	93.56		
							3 <sup>39</sup> / <sub>64</sub>	92.91	91.68	93.87		
				CF300-8XX CS300-8XX	3 <sup>41</sup> / <sub>64</sub>	3 <sup>44</sup> / <sub>64</sub>	3 <sup>40</sup> / <sub>64</sub>	93.24	92.08	94.19		
							3 <sup>41</sup> / <sub>64</sub>	93.55	92.47	94.50		
							3 <sup>42</sup> / <sub>64</sub>	93.85	92.87	94.81		
				CF300-8XX CS300-8XX	3 <sup>41</sup> / <sub>64</sub>	3 <sup>44</sup> / <sub>64</sub>	3 <sup>43</sup> / <sub>64</sub>	94.18	93.66	95.13		
							3 <sup>44</sup> / <sub>64</sub>	94.49	93.66	95.44		
							3 <sup>45</sup> / <sub>64</sub>	94.79	94.06	95.75		
				CF300-9XX CS300-9XX	3 <sup>45</sup> / <sub>64</sub>	3 <sup>48</sup> / <sub>64</sub>	3 <sup>46</sup> / <sub>64</sub>	95.12	95.25	96.07		
							3 <sup>47</sup> / <sub>64</sub>	95.43	94.85	96.38		
							3 <sup>48</sup> / <sub>64</sub>	95.76	95.25	96.69		
				CF300-10XX CS300-10XX	3 <sup>49</sup> / <sub>64</sub>	3 <sup>52</sup> / <sub>64</sub>	3 <sup>49</sup> / <sub>64</sub>	96.06	96.84	97.01		
							3 <sup>50</sup> / <sub>64</sub>	96.37	96.04	97.32		
							3 <sup>51</sup> / <sub>64</sub>	96.70	96.44	97.63		
				CF300-11XX CS300-11XX	3 <sup>53</sup> / <sub>64</sub>	3 <sup>56</sup> / <sub>64</sub>	3 <sup>52</sup> / <sub>64</sub>	97.00	96.84	97.95		
							3 <sup>53</sup> / <sub>64</sub>	97.31	97.23	98.26		
							3 <sup>54</sup> / <sub>64</sub>	97.64	97.63	98.57		
				CF300-12XX CS300-12XX	3 <sup>55</sup> / <sub>64</sub>	3 <sup>60</sup> / <sub>64</sub>	3 <sup>55</sup> / <sub>64</sub>	97.94	98.43	98.89		
							3 <sup>56</sup> / <sub>64</sub>	98.25	98.43	99.20		
							3 <sup>57</sup> / <sub>64</sub>	98.58	98.82	99.52		
				CF300-12XX CS300-12XX	3 <sup>57</sup> / <sub>64</sub>	3 <sup>60</sup> / <sub>64</sub>	3 <sup>58</sup> / <sub>64</sub>	98.88	100.01	99.82		
							3 <sup>59</sup> / <sub>64</sub>	99.19	99.62	100.14		
							3 <sup>60</sup> / <sub>64</sub>	99.52	100.01	100.46		
CF300-13XX CS300-13XX	3 <sup>61</sup> / <sub>64</sub>	4	3 <sup>61</sup> / <sub>64</sub>	99.82	100.41	100.77						
			3 <sup>62</sup> / <sub>64</sub>	100.13	100.81	101.08						
			3 <sup>63</sup> / <sub>64</sub>	100.46	101.20	101.40						
CF300-14XX CS300-14XX	4	4	4	100.76	101.60	101.71						
			4 <sup>1</sup> / <sub>64</sub>	101.07	102.00	102.02						
			4 <sup>2</sup> / <sub>64</sub>	101.40	102.39	102.34						
CF300-14XX CS300-14XX	4 <sup>1</sup> / <sub>64</sub>	4 <sup>1</sup> / <sub>64</sub>	4 <sup>3</sup> / <sub>64</sub>	101.70	102.79	102.65						
			4 <sup>4</sup> / <sub>64</sub>	102.01	103.19	102.96						
			4 <sup>5</sup> / <sub>64</sub>	102.34	103.58	103.28						
CF300-15XX CS300-15XX	4 <sup>5</sup> / <sub>64</sub>	4 <sup>8</sup> / <sub>64</sub>	4 <sup>6</sup> / <sub>64</sub>	102.64	104.78	103.98						
			4 <sup>7</sup> / <sub>64</sub>	102.95	104.38	103.90						
			4 <sup>8</sup> / <sub>64</sub>	103.28	104.78	104.22						
CF300-16XX CS300-16XX	4 <sup>9</sup> / <sub>64</sub>	4 <sup>12</sup> / <sub>64</sub>	4 <sup>9</sup> / <sub>64</sub>	103.58	105.17	104.53						
			4 <sup>10</sup> / <sub>64</sub>	103.89	105.57	104.85						
			4 <sup>11</sup> / <sub>64</sub>	104.22	105.97	105.16						
CF300-16XX CS300-16XX	4 <sup>9</sup> / <sub>64</sub>	4 <sup>12</sup> / <sub>64</sub>	4 <sup>12</sup> / <sub>64</sub>	104.52	106.36	105.47						

Note: Crimp values are in millimeters (± 0.13mm)



## King Crimp™ Recommendation Guide

Hose	Cam & Groove Coupler	Cam & Groove Adaptor	KC Nipple	Ferrule	Hose OD		Hose OD	Crimp Diameter	Hose OD		Hose OD	Crimp Diameter
					From (inch)	To (inch)			From (mm)	To (mm)		
4" Hose ID Imperial Hose = 101.6mm	400-C-AL 400-C-BR 400-C-SS RC400EZCR G400-C-ALCR G400-C-BRCR G400-C-SSCR AL400AL BR400BR SS400SS	400-E-AL 400-E-BR 400-E-SS G400-E-ALCR G400-E-BRCR G400-E-SSCR AL400E BR400E SS400E	ST40CS STC40CS STC40ACS STV40CS STB40CS RST40SS RST40ASS RSTV40SS RSTB40ASS RSTB40SS	CF400-1XX CS400-1XX	4 <sup>13</sup> / <sub>64</sub>	4 <sup>16</sup> / <sub>64</sub>	4 <sup>13</sup> / <sub>64</sub>	110.06	106.76	107.95	106.76	111.30
							4 <sup>14</sup> / <sub>64</sub>	110.36			107.16	111.61
							4 <sup>15</sup> / <sub>64</sub>	59.87			107.55	111.91
							4 <sup>16</sup> / <sub>64</sub>	111.00			107.95	112.22
				CF400-2XX CS400-2XX	4 <sup>17</sup> / <sub>64</sub>	4 <sup>20</sup> / <sub>64</sub>	4 <sup>17</sup> / <sub>64</sub>	111.35	108.35	109.54	108.35	112.61
							4 <sup>18</sup> / <sub>64</sub>	111.66			108.74	112.92
							4 <sup>19</sup> / <sub>64</sub>	111.99			109.14	113.23
							4 <sup>20</sup> / <sub>64</sub>	112.29			109.54	113.54
				CF400-3XX CS400-3XX	4 <sup>21</sup> / <sub>64</sub>	4 <sup>24</sup> / <sub>64</sub>	4 <sup>21</sup> / <sub>64</sub>	112.60	109.93	111.13	106.36	113.84
							4 <sup>22</sup> / <sub>64</sub>	112.90			110.33	114.15
							4 <sup>23</sup> / <sub>64</sub>	113.21			110.73	114.46
							4 <sup>24</sup> / <sub>64</sub>	113.54			111.13	114.77
				CF400-4XX CS400-4XX	4 <sup>25</sup> / <sub>64</sub>	4 <sup>28</sup> / <sub>64</sub>	4 <sup>25</sup> / <sub>64</sub>	113.94	111.52	112.71	111.52	115.20
							4 <sup>26</sup> / <sub>64</sub>	114.25			111.92	115.51
							4 <sup>27</sup> / <sub>64</sub>	114.55			112.32	115.83
							4 <sup>28</sup> / <sub>64</sub>	114.88			112.71	116.14
				CF400-5XX CS400-5XX	4 <sup>29</sup> / <sub>64</sub>	4 <sup>32</sup> / <sub>64</sub>	4 <sup>29</sup> / <sub>64</sub>	115.19	113.11	114.30	113.11	116.45
							4 <sup>30</sup> / <sub>64</sub>	115.49			113.51	116.77
							4 <sup>31</sup> / <sub>64</sub>	115.82			113.90	117.08
							4 <sup>32</sup> / <sub>64</sub>	116.13			114.30	117.39
				CF400-6XX CS400-6XX	4 <sup>33</sup> / <sub>64</sub>	4 <sup>36</sup> / <sub>64</sub>	4 <sup>33</sup> / <sub>64</sub>	116.43	114.70	115.89	114.70	117.71
							4 <sup>34</sup> / <sub>64</sub>	116.76			115.09	118.02
							4 <sup>35</sup> / <sub>64</sub>	117.07			115.49	118.33
							4 <sup>36</sup> / <sub>64</sub>	117.37			115.89	118.65
				CF400-7XX CS400-7XX	4 <sup>37</sup> / <sub>64</sub>	4 <sup>40</sup> / <sub>64</sub>	4 <sup>37</sup> / <sub>64</sub>	117.70	116.28	117.48	116.28	118.96
							4 <sup>38</sup> / <sub>64</sub>	118.01			116.68	119.27
							4 <sup>39</sup> / <sub>64</sub>	118.31			117.08	119.59
							4 <sup>40</sup> / <sub>64</sub>	118.64			117.48	119.90
				CF400-8XX CS400-8XX	4 <sup>41</sup> / <sub>64</sub>	4 <sup>44</sup> / <sub>64</sub>	4 <sup>41</sup> / <sub>64</sub>	118.95	117.87	119.06	117.87	120.21
							4 <sup>42</sup> / <sub>64</sub>	119.25			118.27	120.53
							4 <sup>43</sup> / <sub>64</sub>	119.58			118.67	120.84
							4 <sup>44</sup> / <sub>64</sub>	119.89			119.06	121.16
				CF400-9XX CS400-9XX	4 <sup>45</sup> / <sub>64</sub>	4 <sup>48</sup> / <sub>64</sub>	4 <sup>45</sup> / <sub>64</sub>	120.19	119.46	120.65	119.46	121.47
							4 <sup>46</sup> / <sub>64</sub>	120.52			119.86	121.78
							4 <sup>47</sup> / <sub>64</sub>	120.83			120.25	122.10
							4 <sup>48</sup> / <sub>64</sub>	121.16			120.65	122.41
				CF400-10XX CS400-10XX	4 <sup>49</sup> / <sub>64</sub>	4 <sup>52</sup> / <sub>64</sub>	4 <sup>49</sup> / <sub>64</sub>	121.46	121.05	122.24	121.05	122.24
							4 <sup>50</sup> / <sub>64</sub>	121.77			121.44	123.04
							4 <sup>51</sup> / <sub>64</sub>	122.10			121.84	123.35
							4 <sup>52</sup> / <sub>64</sub>	122.40			122.24	123.66
				CF400-11XX CS400-11XX	4 <sup>53</sup> / <sub>64</sub>	4 <sup>56</sup> / <sub>64</sub>	4 <sup>53</sup> / <sub>64</sub>	122.71	122.63	123.83	122.63	123.83
							4 <sup>54</sup> / <sub>64</sub>	123.04			123.03	124.29
							4 <sup>55</sup> / <sub>64</sub>	123.34			123.43	124.60
							4 <sup>56</sup> / <sub>64</sub>	123.65			123.83	124.92
				CF400-12XX CS400-12XX	4 <sup>57</sup> / <sub>64</sub>	4 <sup>60</sup> / <sub>64</sub>	4 <sup>57</sup> / <sub>64</sub>	123.98	124.22	125.41	124.22	125.23
							4 <sup>58</sup> / <sub>64</sub>	124.28			124.62	125.54
							4 <sup>59</sup> / <sub>64</sub>	124.59			125.02	125.86
							4 <sup>60</sup> / <sub>64</sub>	124.92			125.41	126.17
CF400-13XX CS400-13XX	4 <sup>61</sup> / <sub>64</sub>	5	4 <sup>61</sup> / <sub>64</sub>	125.22	125.81	127.00	125.81	126.49				
			4 <sup>62</sup> / <sub>64</sub>	125.53			126.21	126.80				
			4 <sup>63</sup> / <sub>64</sub>	125.86			126.60	127.11				
			5	126.16			127.00	127.43				
CF400-14XX CS400-14XX	5 <sup>1</sup> / <sub>64</sub>	5 <sup>4</sup> / <sub>64</sub>	5 <sup>1</sup> / <sub>64</sub>	126.47	127.40	128.59	127.40	127.74				
			5 <sup>2</sup> / <sub>64</sub>	126.80			127.79	128.05				
			5 <sup>3</sup> / <sub>64</sub>	127.10			128.19	128.37				
			5 <sup>4</sup> / <sub>64</sub>	127.41			128.59	128.68				
CF400-15XX CS400-15XX	5 <sup>5</sup> / <sub>64</sub>	5 <sup>8</sup> / <sub>64</sub>	5 <sup>5</sup> / <sub>64</sub>	127.74	128.98	130.18	128.98	128.99				
			5 <sup>6</sup> / <sub>64</sub>	128.04			129.38	129.31				
			5 <sup>7</sup> / <sub>64</sub>	128.35			129.78	129.62				
			5 <sup>8</sup> / <sub>64</sub>	128.68			130.18	129.93				
CF400-16XX CS400-16XX	5 <sup>9</sup> / <sub>64</sub>	5 <sup>12</sup> / <sub>64</sub>	5 <sup>9</sup> / <sub>64</sub>	128.98	130.57	131.76	130.57	130.25				
			5 <sup>10</sup> / <sub>64</sub>	129.29			130.97	130.56				
			5 <sup>11</sup> / <sub>64</sub>	129.62			131.37	130.87				
				5 <sup>12</sup> / <sub>64</sub>	129.92		131.76	131.19				

Note: Crimp values are in millimeters (± 0.13mm)





## Valve Selection Guide

### Ball Valve

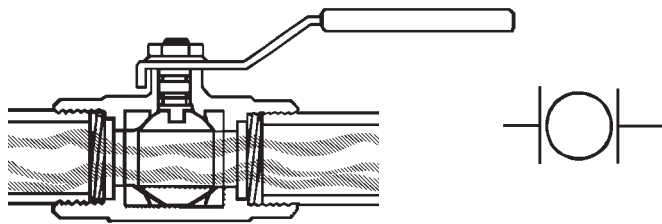

- Can be used for on and off service or throttling
- When positive shut-off is necessary
- Where a low valve profile is necessary
- Only 90° rotation from open to fully closed quick opening
- Handle position is a quick indication of whether valve is open or closed
- Full port ball valves do not resist flow

### Butterfly Valve

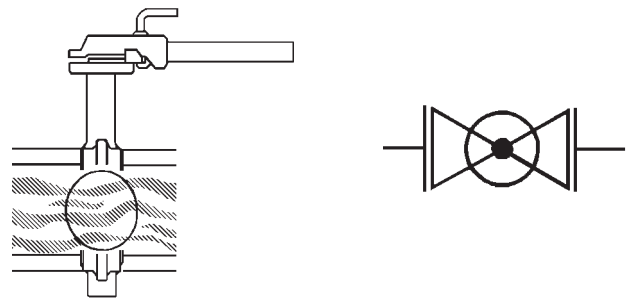

- Where positive shut-off is necessary
- Primarily for fully open or fully closed applications
- May be used for throttling
- Only 90° rotation from open to fully closed
- Lightweight
- Easy to install
- Less costly than an iron body gate valve

### Check Valve

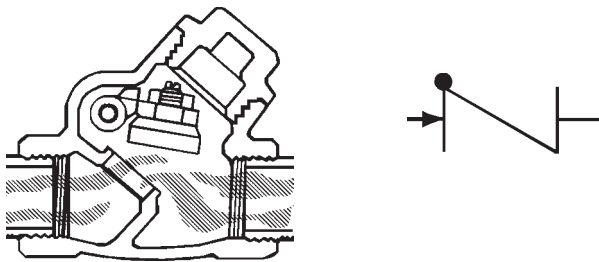

- To control the direction of flow and for quick, automatic reactions to flow change. Swing check valves are used when a minimum resistance to flow is required.
- Swing check valves are recommended for use in conjunction with gate valves. They should not be used in a rapid recycling system such as reciprocating pumps or air compressor service where they could cause chatter and damaging vibration.

### Gate Valve

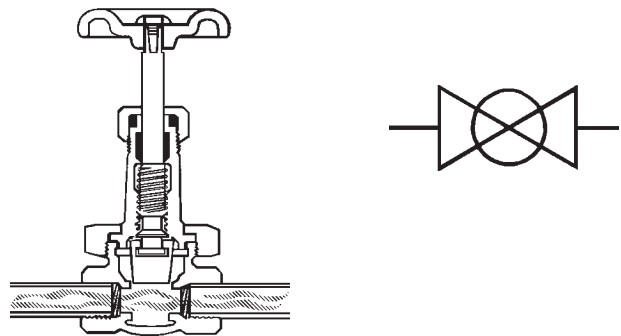

- For fully open or fully closed service **not for throttling**
- For minimum line pressure drop
- For minimum fluid entrapment in the line
- For relatively infrequent operation

### Globe Valve

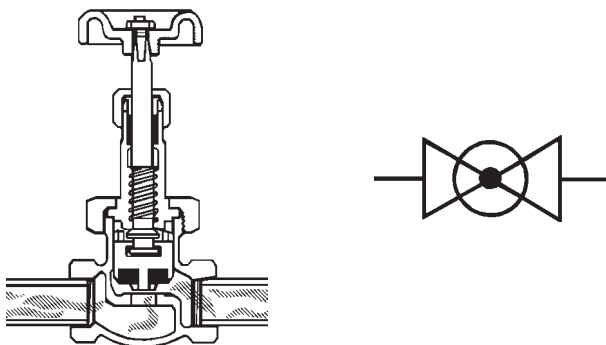

- For regulation (throttling) of flow
- For frequent operation; short stem travel reduces operator's time
- Where some line resistance is acceptable

## Steam Temperature - Pressure Conversion Guide

### Temperature - Pressure Equivalents of Saturated Steam Gauge Pressure at Sea Level

Temperature		PSI	Temperature		PSI	Temperature		PSI
°F	°C		°F	°C		°F	°C	
212	100.0	0.0	286	141.1	39.4	336	168.9	97.1
214	101.1	0.6	287	141.7	40.3	337	169.4	98.7
216	102.2	1.2	288	142.2	41.1	338	170.0	100.2
218	103.3	1.8	289	142.8	42.0	339	170.6	101.8
220	104.4	2.5	290	143.3	42.9	340	171.1	103.3
222	105.6	3.2	291	143.9	43.8	341	171.7	105.0
224	106.7	3.9	292	144.4	44.7	342	172.2	106.5
226	107.8	4.6	293	145.0	45.6	343	172.8	108.2
228	108.9	5.3	294	145.6	46.5	344	173.3	109.8
230	110.0	6.1	295	146.1	47.5	345	173.9	111.5
232	111.1	6.9	296	146.7	48.4	346	174.4	113.1
234	112.2	7.7	297	147.2	49.4	347	175.0	114.8
236	113.3	8.5	298	147.8	50.3	348	175.6	116.5
238	114.4	9.4	299	148.3	51.3	349	176.1	118.2
240	115.6	10.3	300	148.9	52.3	350	176.7	119.9
242	116.7	11.2	301	149.4	53.4	352	177.8	123.5
244	117.8	12.1	302	150.0	54.4	354	178.9	127.1
246	118.9	13.1	303	150.6	55.4	356	180.0	130.8
248	120.0	14.1	304	151.1	56.4	358	181.1	134.5
250	121.1	15.1	305	151.7	57.5	360	182.2	138.3
252	122.2	16.2	306	152.2	58.6	362	183.3	142.3
254	123.3	17.3	307	152.8	59.7	364	184.4	146.2
256	124.4	18.4	308	153.3	60.7	366	185.6	150.3
258	125.6	19.6	309	153.9	61.9	368	186.7	154.4
260	126.7	20.7	310	154.4	63.0	370	187.8	158.7
261	127.2	21.4	311	155.0	64.2	372	188.9	163.0
262	127.8	22.0	312	155.6	65.3	374	190.0	167.4
263	128.3	22.6	313	156.1	66.5	376	191.1	171.9
264	128.9	23.2	314	156.7	67.6	378	192.2	176.4
265	129.4	23.9	315	157.2	68.8	380	193.3	181.1
266	130.0	24.5	316	157.8	70.0	382	194.4	185.8
267	130.6	25.2	317	158.3	71.3	384	195.6	190.6
268	131.1	25.8	318	158.9	72.5	386	196.7	195.6
269	131.7	26.5	319	159.4	73.7	388	197.8	200.6
270	132.2	27.2	320	160.0	75.0	390	198.9	205.7
271	132.8	27.9	321	160.6	76.3	392	200.0	210.9
272	133.3	28.6	322	161.1	77.5	394	201.1	216.2
273	133.9	29.3	323	161.7	78.8	396	202.2	221.5
274	134.4	30.0	324	162.2	80.1	398	203.3	227.0
275	135.0	30.8	325	162.8	81.5	400	204.4	232.6
276	135.6	31.5	326	163.3	82.8	402	205.5	238.0
277	136.1	32.3	327	163.9	84.2	404	206.7	244.0
278	136.7	33.0	328	164.4	85.6	406	207.8	250.0
279	137.2	33.8	329	165.0	87.0	408	208.9	256.0
280	137.8	34.5	330	165.6	88.4	410	210	262.0
281	138.3	35.3	331	166.1	89.8	412	211.1	268.0
282	138.9	36.1	332	166.7	91.2	414	212.2	275.0
283	139.4	36.9	333	167.2	92.7	416	213.3	281.0
284	140.0	37.7	334	167.8	94.1	418	214.4	288.0
285	140.6	38.6	335	168.3	95.6	420	215.6	294.0

Degrees Celsius = 5/9 (Degrees F -32)



## Vacuum Conversions

ATM	PSI	Water		Mercury		Percentage %
		Metre	Feet	mm	inch	
0.1	1.4	1	3' 3 <sup>3</sup> / <sub>8</sub> "	73.6	2.9	10
0.2	2.8	2	6' 6 <sup>3</sup> / <sub>4</sub> "	147.1	5.8	20
0.3	4.2	3	9' 10 <sup>1</sup> / <sub>8</sub> "	220.7	8.7	30
0.4	5.7	4	13' 1 <sup>1</sup> / <sub>2</sub> "	294.2	11.6	40
0.5	7.1	5	16' 4-13/16"	367.8	14.5	50
0.6	8.5	6	19' 8-3/16"	441.3	17.4	60
0.7	10.0	7	22' 11-9/16"	514.9	20.3	70
0.8	11.4	8	26' 2-15/16"	588.4	23.2	80
0.9	12.8	9	29' 6 <sup>3</sup> / <sub>8</sub> "	662.00	26.0	90
1.0	14.2	10	32' 9-11/16"	735.5	29.0	100

## Feet of Water to Inches of Mercury Conversions

Feet of Water	1	2	4	6	8	10	12	14	16	20	22	24	26	28	30	32	34
Inches of Mercury	0.9	1.8	3.5	5.3	7.1	8.8	10.6	12.4	14.1	17.7	19.4	21.2	23.0	24.8	26.5	28.3	30.0

## Pressure Conversions

**100 PSI = 6.9 Bar** | **5 Bar = 72.5 PSI**  
**250 PSI = 17.25 Bar** | **10 Bar = 145 PSI**  
**600 PSI = 41.4 Bar** | **25 Bar = 362.5 PSI**

## Measurement Information

### Measures of Pressure:

1 Pound Per Square Inch = 144 Pounds Per Square Foot = 0.068 Atmosphere = 2.042 Inches of Mercury at 62°F = 27.7 Inches of Water at 62°F = 2.31 Feet of Water at 62°F.

1 Atmosphere = 30 Inches of Mercury at 62°F = 14.7 Pounds Per Square Inch = 2116.3 Pounds Per Square Foot = 33.95 Feet of Water at 62°F.

1 Foot of Water at 62°F = 62.355 Pounds Per Square Foot = 0.433 Pounds Per Square Inch.

1 Inch of Mercury at 62°F = 1.132 Feet of Water = 13.58 Inches of Water = 0.491 Pounds Per Square Inch.

Column of Water 12 Inches High, 1 Inch in Diameter = .341 Pounds

### Length Conversion Constants:

Millimeters x .039370 = Inches	Inches x 25.4001 = Millimeters
Meters x 39.370 = Inches	Inches x .0254 = Meters
Meters x 3.2808 = Feet	Feet x .30480 = Meters
Meters x 1.09361 = Yards	Yards x .91440 = Meters
Kilometers x 3,280.8 = Feet	Feet x .0003048 = Kilometers
Kilometers x .62137 = Statute Mile	Statute Miles x 1.60935 = Kilometers
Kilometers x .53959 = Nautical Miles	Nautical Miles x 1.85325 = Kilometers

### Weight Conversion Constants:

Grams x .03527 = Ounces (Avd.)	Ounces (Avd.) x 28.35 = Grams
Grams x .033818 = Fluid Ounces (Water)	Fluid Ounces (Water) x 29.57 = Grams
Kilograms x 35.27 = Ounces (Avd.)	Ounces (Avd.) x .02835 = Kilograms
Kilograms x 2.20462 = Pounds (Avd.)	Pounds (Avd.) x .45359 = Kilograms



# Safety & Technical

## Imperial to Decimal Conversions

	<u>Inches</u>	<u>Millimeters</u>		<u>Inches</u>	<u>Millimeters</u>	
	<b><math>\frac{1}{64}</math></b>	<b>.015625</b>	<b>.3969</b>	<b><math>\frac{33}{64}</math></b>	<b>.515625</b>	<b>13.0969</b>
$\frac{1}{32}$		.03125	.7938	$\frac{17}{32}$	.53125	13.4938
	<b><math>\frac{3}{64}</math></b>	<b>.046875</b>	<b>1.1906</b>	<b><math>\frac{35}{64}</math></b>	<b>.546875</b>	<b>13.8907</b>
$\frac{1}{16}$		.0625	1.5875	$\frac{9}{16}$	.5625	14.2876
	<b><math>\frac{5}{64}</math></b>	<b>.078125</b>	<b>1.9844</b>	<b><math>\frac{37}{64}</math></b>	<b>.578125</b>	<b>14.6844</b>
$\frac{3}{32}$		.09375	2.3813	$\frac{19}{32}$	.59375	15.0813
	<b><math>\frac{7}{64}</math></b>	<b>.109375</b>	<b>2.7781</b>	<b><math>\frac{39}{64}</math></b>	<b>.609375</b>	<b>15.4782</b>
$\frac{1}{8}$		.125	3.1750	$\frac{5}{8}$	.625	15.8751
	<b><math>\frac{9}{64}</math></b>	<b>.140625</b>	<b>3.5719</b>	<b><math>\frac{41}{64}</math></b>	<b>.640625</b>	<b>16.2719</b>
$\frac{5}{32}$		.15625	3.9688	$\frac{21}{32}$	.65625	16.6688
	<b><math>\frac{11}{64}</math></b>	<b>.171875</b>	<b>4.3656</b>	<b><math>\frac{43}{64}</math></b>	<b>.671875</b>	<b>17.0657</b>
$\frac{3}{16}$		.1875	4.7625	$\frac{11}{16}$	.6875	17.4626
	<b><math>\frac{13}{64}</math></b>	<b>.203125</b>	<b>5.1594</b>	<b><math>\frac{45}{64}</math></b>	<b>.703125</b>	<b>17.8594</b>
$\frac{7}{32}$		.21875	5.5563	$\frac{23}{32}$	.71875	18.2563
	<b><math>\frac{15}{64}</math></b>	<b>.234375</b>	<b>5.9531</b>	<b><math>\frac{47}{64}</math></b>	<b>.734375</b>	<b>18.6532</b>
$\frac{1}{4}$		.250	6.3500	$\frac{3}{4}$	.750	19.0501
	<b><math>\frac{17}{64}</math></b>	<b>.265625</b>	<b>6.7469</b>	<b><math>\frac{49}{64}</math></b>	<b>.765625</b>	<b>19.4470</b>
$\frac{9}{32}$		.28125	7.1438	$\frac{25}{32}$	.78125	19.8438
	<b><math>\frac{19}{64}</math></b>	<b>.296875</b>	<b>7.5406</b>	<b><math>\frac{51}{64}</math></b>	<b>.796875</b>	<b>20.2407</b>
$\frac{5}{16}$		.3125	7.9375	$\frac{13}{16}$	.8125	20.6376
	<b><math>\frac{21}{64}</math></b>	<b>.328125</b>	<b>8.3344</b>	<b><math>\frac{53}{64}</math></b>	<b>.828125</b>	<b>21.0345</b>
$\frac{11}{32}$		.34375	8.7313	$\frac{27}{32}$	.84375	21.4313
	<b><math>\frac{23}{64}</math></b>	<b>.359375</b>	<b>9.1282</b>	<b><math>\frac{55}{64}</math></b>	<b>.859375</b>	<b>21.8282</b>
$\frac{3}{8}$		.375	9.5250	$\frac{7}{8}$	.875	22.2251
	<b><math>\frac{25}{64}</math></b>	<b>.390625</b>	<b>9.9219</b>	<b><math>\frac{57}{64}</math></b>	<b>.890625</b>	<b>22.6220</b>
$\frac{13}{32}$		.40625	10.3188	$\frac{29}{32}$	.90625	23.0188
	<b><math>\frac{27}{64}</math></b>	<b>.421875</b>	<b>10.7157</b>	<b><math>\frac{59}{64}</math></b>	<b>.921875</b>	<b>23.4157</b>
$\frac{7}{16}$		.4375	11.1125	$\frac{15}{16}$	.9375	23.8126
	<b><math>\frac{29}{64}</math></b>	<b>.453125</b>	<b>11.5094</b>	<b><math>\frac{61}{64}</math></b>	<b>.953125</b>	<b>24.2095</b>
$\frac{15}{32}$		.46875	11.9063	$\frac{31}{32}$	.96875	24.6063
	<b><math>\frac{31}{64}</math></b>	<b>.484375</b>	<b>12.3032</b>	<b><math>\frac{63}{64}</math></b>	<b>.984375</b>	<b>25.0032</b>
$\frac{1}{2}$		.500	12.7001	1	1.000	25.4001



## Temperature Conversions

Look up reading in middle/Centre column (°F/°C) . If in degrees Centigrade, read Fahrenheit equivalent in right-hand column; if in degrees Fahrenheit, read Centigrade equivalent in left-hand column.

°C	°F/°C	°F
-73	-100	-148
-68	-90	-130
-62	-80	-112
-57	-70	-94
-51	-60	-76
-46	-50	-58
-40	-40	-40
-34	-30	-22
-29	-20	-4
-23	-10	14
-17.8	0	32
-17.2	1	33.8
-16.7	2	35.6
-16.1	3	37.4
-15.6	4	39.2
-15.0	5	41.0
-14.4	6	42.8
-13.9	7	44.6
-13.3	8	46.4
-12.8	9	48.2
-12.2	10	50.0
-11.7	11	51.8
-11.1	12	53.6
-10.6	13	55.4
-10.0	14	57.2
-9.4	15	59.0
-8.9	16	60.8
-8.3	17	62.6
-7.8	18	64.4
-7.2	19	66.2
-6.7	20	68.0
-6.1	21	69.8
-5.6	22	71.6
-5.0	23	73.4
-4.4	24	75.2
-3.9	25	77.0
-3.3	26	78.8
-2.8	27	80.6
-2.2	28	82.4
-1.7	29	84.2
-1.1	30	86.0
-6	31	87.8
0	32	89.6
.6	33	91.4
1.1	34	93.2
1.7	35	95.0
2.2	36	96.8
2.8	37	98.6
3.3	38	100.4
3.9	39	102.2
4.4	40	104.0

°C	°F/°C	°F
5.0	41	105.8
5.6	42	107.6
6.1	43	109.4
6.7	44	111.2
7.2	45	113.0
7.8	46	114.8
8.3	47	116.6
8.9	48	118.4
9.4	49	120.2
10.0	50	122.0
10.6	51	123.8
11.1	52	125.6
11.7	53	127.4
12.2	54	129.2
12.8	55	131.0
13.3	56	132.8
13.9	57	134.6
14.4	58	136.4
15.0	59	138.2
15.6	60	140.0
16.1	61	141.8
16.7	62	143.6
17.2	63	145.4
17.8	64	147.2
18.3	65	149.0
18.9	66	150.8
19.4	67	152.6
20.0	68	154.4
20.6	69	156.2
21.1	70	158.0
21.7	71	159.8
22.2	72	161.6
22.8	73	163.4
23.3	74	165.2
23.9	75	167.0
24.4	76	168.8
25.0	77	170.6
25.6	78	172.4
26.1	79	174.2
26.7	80	176.0
27.2	81	177.8
27.8	82	179.6
28.3	83	181.4
28.9	84	183.2
29.4	85	185.0
30.0	86	186.8
30.6	87	188.6
31.1	88	190.4
31.7	89	192.2
32.2	90	194.0
32.8	91	195.8

°C	°F/°C	°F
33.3	92	197.6
33.9	93	199.4
34.4	94	201.2
35.0	95	203.0
35.6	96	204.8
36.1	97	206.6
36.7	98	208.4
37.2	99	210.2
37.8	100	212.0
43	110	230
49	120	248
54	130	266
60	140	284
66	150	302
71	160	320
77	170	338
82	180	356
88	190	374
93	200	392
99	210	410
100	212	413.6
104	220	428
110	230	446
116	240	464
121	250	482
127	260	500
132	270	518
138	280	536
143	290	554
149	300	572
154	310	590
160	320	608
166	320	626
170	338	640
171	340	644
177	350	662
182	360	680
186	366	691
188	370	698
193	380	716
198	388	730
199	390	734
204	400	752
208	406	763
210	410	770
216	420	788
221	430	806
227	440	824
232	450	842



## Theoretical Horsepower to Compress Air

**HP** = Compressed horsepower

**CFM** = Air volume in cubic feet per minute

**PSI** = Air pressure in pounds per square inch  
(assumes atmospheric pressure)  
= 14.7 PSI, temperature = 15°C (60°F)

$$\text{HP} = \text{CFM} \times \text{PSI} \times .0007575$$

## Air Volume Discharged from Pipe

**CFM** = Air volume in cubic feet per minute

**V** = Air velocity in feet per second as determined  
in the equation at the top of this page

**A** = Cross section area of pipe in square feet

$$\text{CFM} = 60VA$$

## Boyle's Law

If temperature is kept constant, the volume of a given mass of gas is inversely proportional to the pressure which is exerted upon it.

$$\frac{\text{Initial Pressure}}{\text{Final Pressure}} = \frac{\text{Final Volume}}{\text{Initial Volume}}$$

## Circle Geometry

$$\text{Circumference} = 2 \pi r = \pi d = 3.14 d$$

$$\text{Area} = \pi r^2 = \pi \frac{d^2}{4} = .785d^2$$

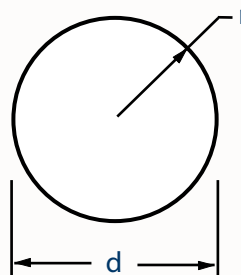

## Right Cylinder

**r** = radius

**h** = length

$$\text{Volume} = \pi r^2 h$$

$$\text{Surface Area} = 2 \pi r (r + h)$$

If end planes are parallel but not at 90° to h, the same formulas apply, but a slice at 90° through the cylinder must be used to determine r.

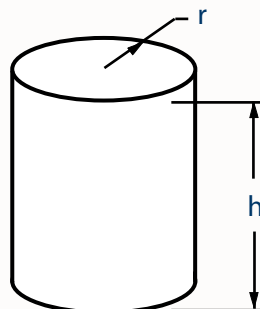

## MSHA (Mine Safety and Health Administration) Regulations

### 30 CFR Sections 56.13021 and 57.13021

Except where automatic shut-off valves are used, safety chains or other suitable locking devices shall be used at connections to machines of high-pressure hose line of  $\frac{3}{4}$ " inside diameter or larger, and between high-pressure hose lines of  $\frac{3}{4}$ " inside diameter or larger, where a connection failure would create a hazard.

### 30 CFR Section 75.1730

(e) Safety chains, suitable locking devices, or automatic cut-off valves shall be used at connections to machines of high-pressure hose lines of  $\frac{3}{4}$ " inside diameter or larger, and between high-pressure hose lines of  $\frac{3}{4}$ " inside diameter or larger, where a connection failure would create a hazard. For the purposes of this paragraph, high-pressure means pressure of **100 PSI** or more.

### 30 CFR Section 77.412

(d) Safety chains or suitable locking devices shall be used at connections to machines of high-pressure hose line of 1" inside diameter or larger, and between high-pressure hose line of 1" inside diameter or larger, where a connection failure would create a hazard.

## OSHA Regulations

### Standards - 29 CFR, 1910.242 (partial):

(b) Compressed air used for cleaning - compressed air shall not be used for cleaning purposes except where reduced to less than **30 PSI** and then only with effective chip guarding and personal protective equipment.

### Standards - 29 CFR, 1915.131 (partial):

(e) Before use, pneumatic tools shall be secured to the extension hose or whip by some positive means to prevent the tool from becoming accidentally disconnected from the whip.

### Standards - 29 CFR, 1926.302 (partial):

- (b) (1) Pneumatic power tools shall be secured to the hose or whip by some positive means to prevent the tool from becoming accidentally disconnected.
- (b) (2) Safety clips or retainers shall be securely installed and maintained on pneumatic impact (percussion) tools to prevent attachments from being accidentally expelled.
- (b) (3) All pneumatically driven nailers, staplers and other similar equipment provided with automatic fastener feed, which operate at more than **100 PSI** pressure at the tool shall have a safety device on the muzzle to prevent the tool from ejecting fasteners, unless the muzzle is in contact with the work surface.
- (b) (4) Compressed air shall not be used for cleaning purposes except where reduced to **30 PSI** and then only with effective chip guarding and personal protective equipment which meets the requirements of Subpart E of this part. The **30 PSI** requirement does not apply for concrete form, mill scale, and similar cleaning purposes.
- (b) (5) The manufacturers' safe operating pressure for hoses, pipes, valves, filters and other fittings shall not be exceeded.
- (b) (6) The use of hoses for hoisting or lowering tools shall not be permitted.
- (b) (7) All hoses exceeding  $\frac{1}{2}$ " inside diameter shall have a safety device at the source of supply or branch line to reduce pressure in case of hose failure.

### Standards - 29 CFR, 1926.306

#### (a) "General requirements"

- (a) (1) **"Application."** This section applies to compressed air receivers, and other equipment used in providing and utilizing compressed air for performing operations such as cleaning, drilling, hoisting, and chipping. On the other hand, however, this section does not deal with the special problems created by using compressed air to convey materials, nor the problems created when men work in compressed air as in tunnels and caissons. This section is not intended to apply to compressed air machinery and equipment used on transportation vehicles such as steam railroad cars, electric railway cars, and automotive equipment.
- (a) (2) **"New and existing equipment."**
  - (a) (2) (i) All new air receivers installed after the effective date of these regulations shall be constructed in accordance with the 1968 edition of the A.S.M.E. Boiler and Pressure Vessel Code Section VIII.
  - (a) (2) (ii) All safety valves used shall be constructed, installed and maintained in accordance with the A.S.M.E. Boiler and Pressure Vessel Code, Section VIII Edition 1968.

#### (b) 1926.306

##### (b) "Installation and equipment requirements"

- (b) (1) **"Installation."** Air receivers shall be so installed that all drains, handholes, and manholes therein are easily accessible. Under no circumstances shall an air receiver be buried underground or located in an inaccessible place.
- (b) (2) **"Drains and traps."** A drain pipe and valve shall be installed at the lowest point of every air receiver to provide for the removal of accumulated oil and water. Adequate automatic traps may be installed in addition to drain valves. The drain valve on the air receiver shall be opened and the receiver completely drained frequently and at such intervals as to prevent the accumulation of excessive amounts of liquid in the receiver.
- (b) (3) **"Gauges and valves"**
  - (b) (3) (i) Every air receiver shall be equipped with an indicating pressure gage (so located as to be readily visible) and with one or more spring-loaded safety valves. The total relieving capacity of such safety valves shall be such as to prevent pressure in the receiver from exceeding the maximum allowable working pressure of the receiver by more than 10 percent.
  - (b) (3) (ii) No valve of any type shall be placed between the air receiver and its safety valve or valves.

### Standards - 29 CFR, 1926.603 (partial):

- (a) (9) Steam hose leading to a steam hammer or jet pipe shall be securely attached to the hammer with an adequate length of at least  $\frac{1}{4}$ " diameter chain or cable to prevent whipping in the event the joint at the hammer is broken. Air hammer hoses shall be provided with the same protection as required for steam lines.
- (a) (10) Safety chains, or equivalent means, shall be provided for each hose connection to prevent the line from thrashing around in case the coupling becomes disconnected.

The regulations may be viewed in full on the OSHA website, [osha.gov](http://osha.gov). Please check the website for updates.

## Hose & Coupling Site Safety Survey

At Dixon™ we recognise the need for onsite safety and how understanding the importance this holds and helps generate a stronger relationship with your customer.

As a result Dixon™ now offers hose and coupling safety surveys.

Today, plant safety is an ongoing endeavour where it is impossible to be an expert in every field. The use of damaged or misapplied hose couplings and related items occurs. To the untrained eye these hazards may continue to exist until an accident happens threatening not only plant machinery but also the well-being of personnel.

Dixon™ can assist in your efforts to make the facilities you service as safe, efficient, and productive as possible.



## Onsite Hose Testing & Management

Dixon™ offers a hose management programme designed to help make your facilities as safe, efficient, and productive as possible.

The hose management program includes the regular test and inspection of onsite hoses along with a web based documentation and management tool.

Dixon™-Hose Connect is a secure, user friendly web based app. It is a source to allow you to access your hose maintenance documentation, including service history reports and hose asset register via unique tag references and hose identifiers, as well as training videos for your site.

### OUR PROGRAM INCLUDES:

- A visual inspection of hose assemblies and related accessories
- A professionally written report detailing our observations and recommendations for corrective action
- The safety survey report is completely confidential and will only be shown to authorised parties

#### Don't Forget:

Hoses from Dixon™ are Certified to PED 2014/68/EU Module D1 by Lloyds Register Quality Assurance.

When it's got to be right, it's got to be Dixon™.

For more information contact Dixon™ today on +44 (0)1772 323529 or sales@dixoneurope.co.uk



## A

<b>A.N.S.I.</b>	American National Standards Institute, Inc.
<b>A.P.I.</b>	American Petroleum Institute
<b>A.S.M.E.</b>	American Society of Mechanical Engineers
<b>A.S.T.M.</b>	American Society for Testing and Materials
<b>Anodise</b>	A process for aluminium, similar to zinc or chrome-plating steel, in which an aluminium part is electrically charged then dipped in various chemicals to produce various colours and/or surface hardness.

## B

<b>Burst Pressure</b>	The pressure at which rupture occurs.
-----------------------	---------------------------------------

## C

<b>Chamfer</b>	To cut an angle on the hose tube to aid in stem insertion and to prevent the hose end from flaring when a stem is inserted.
<b>Clamp</b>	A metal fitting, band, or wire used around the outside of a hose end to secure a coupling, fitting, or nipple.
<b>Cold Flow</b>	Continued deformation or movement of rubber under stress.
<b>Compression Set</b>	The deformation that remains in rubber after it has been subjected to and released from stress such as a clamp. The longer the stress is maintained the more definitive the deformation.
<b>Coupling</b>	A device at the end or ends of a length of hose that allows a connection to be made.
<b>Crimping</b>	The act of forming the metal sleeve or ferrule of a hose fitting with a surrounding series of die segments to compress the hose within the fitting. The crimping process changes the shape of the entire circumference and length simultaneously. Often interchanged with the term "swaged".

## D

<b>Durometer</b>	An instrument for measuring the hardness of rubber.
<b>Durometer Hardness</b>	A numerical value which indicates the resistance to indentation of the blunt indenter of the durometer.

## E

<b>Elastomer</b>	Any of various elastic substances resembling rubber.
<b>Expansion Ring</b>	Typically refers to a type of fire hose couplings that are attached by expanding a sleeve (usually brass) outward to compress the hose against the wall of the bowl of the coupling.
<b>External Swage (Swaging)</b>	A ferrule is passed through a reducing die, usually split, to bring the ferrule O.D. down to a predetermined size (for proper coupling retention) forcing the hose tube down into the stem serrations.

## F

<b>Ferrule</b>	A collar placed over a hose end to attach the fitting to the hose. The ferrule may be crimped or swaged, forcing the hose against the shank of the coupling, or the shank may be expanded, forcing the hose out against the ferrule, or both.
----------------	---

## G

<b>Gripping Finger</b>	The part of the clamp that goes over and behind the stem collar to aid in clamp retention.
------------------------	--

## H

<b>Hard Coat</b>	An anodizing process in which the surface hardness of aluminium becomes similar to or greater than that of case-hardened steel.
------------------	---

## I

<b>Internal Expansion (I.X.)</b>	A plug (or bullet) is pulled through a stem or a set of blades (fingers) increase the stem I.D. to the plug O.D. or a predetermined setting when using expansion blades (fingers). This forces the stem serrations into the hose tube and the hose cover into the serrations of the ferrule.
----------------------------------	--

## J

<b>J.I.C.</b>	Joint Industrial Committee
<b>J.I.C. Thread</b>	Typically refers to the threads on hydraulic fittings having 37° conical sealing surfaces.

## M

<b>M.S.H.A.</b>	Mine Safety and Health Administration
-----------------	---------------------------------------

# Glossary of Terms

## N

<b>Nipple</b>	The section of the fitting that is inserted into the hose. Also known as the shank of a coupling.
<b>Nominal</b>	A dimensional value assigned for the purpose of convenient designation.

## O

<b>Operating Pressure</b>	The pressure at which system functions. Also known as Working Pressure.
<b>ORB Thread</b>	O-ring Boss™ Thread

## P

<b>P.S.I.</b>	Pounds per square inch
<b>P.S.I.G.</b>	Pounds per square inch gauge
<b>Permanent Fitting</b>	The type of fitting which, after it is applied, cannot be removed for reuse.
<b>Polymer</b>	A macromolecular material formed by the chemical combination of monomers having the same or different chemical composition.
<b>Proof Pressure</b>	A specified pressure which exceeds the hose assemblies rated working pressure to indicate its reliability at normal working pressure. Follow R.M.A.'s testing guidelines for specific pressures and durations for various types of hose.

## R

<b>R.M.A.</b>	Rubber Manufacturers' Association
<b>Reusable Fitting</b>	The type of fitting that is designed to be removed from a hose and recoupled on another hose.

## S

<b>S.A.E.</b>	Society of Automotive Engineers
<b>S.A.E. Threads</b>	Similar to J.I.C. except 45° conical sealing surfaces.
<b>S.C.F.M.</b>	Standard Cubic Feet per Minute. Typically refers to the amount of compressed air a compressor can produce.
<b>Safety Factor</b>	A ratio used to establish the working pressure of a hose based upon the burst pressure. Typical Safety Factors are as follows: <ol style="list-style-type: none"> <li>1. Water hose up to <b>150 PSI</b> WP: 3 to 1.</li> <li>2. Hose for all other liquids, solid materials suspended in liquids or air and water hose over <b>150 PSI</b> WP: 4 to 1.</li> <li>3. Hose for compressed air and other gases: 4 to 1.</li> <li>4. Hose for liquid media that immediately changes into gas under standard atmospheric conditions: 5 to 1.</li> <li>5. Steam hose: 10 to 1.</li> </ol>
<b>Serration</b>	The part of the shank (stem) that grips the hose tube.
<b>Shank</b>	The section of the fitting or coupling that is inserted into the hose.
<b>Sintered</b>	Process in which powdered metal is formed in a mold under extreme pressure to form a finished part.
<b>Surge</b>	A rapid rise and decrease of internal pressure.

## T

<b>Torque</b>	Amount of force required to turn an object. Usually measured in inch pounds (in. lbs.) or foot pounds (ft. lbs.)
<b>Tube</b>	The innermost part of the hose that's purpose is to contain the media being transported. Usually, rubber compounds or plastics are blended to give the tube specific properties so that it is compatible with certain media.

## U

<b>U.H.M.W.</b>	Ultra High Molecular Weight. Next generation of chemical hoses after cross-linked polyethylene having a thin tube liner made from extremely dense material giving it excellent chemical resistance properties.
-----------------	--

## W

<b>W.O.G.</b>	Water, Oil, Gas. Pressure rating for valves handling these products. This does not include steam.
<b>W.P.</b>	Working Pressure
<b>Working Pressure</b>	The maximum pressure to which a hose assembly will be subjected to, including during pressure surges.

## X

<b>X.L.P.E.</b>	Cross-Linked Polyethylene. Tube material that has good chemical resistance properties.
-----------------	--

## Part Number Index

*AGBF*	231	*KDP	198	*WSBF*-SS	206	**WSF**	206
*AGBF*-PV	231	*KDP-K*DC	198	*WSDP-A	210	**WSF**_BOP	207
*AGDP	231	*KF*	199	*WSF*	206	**WSF**_SS-BOP	207
*AGF*	231	*KOF*	199	*WSF*-BOP	207	**WS-RKIT	210
*AGF*-PS	232	*K-SKIT	198	*WSF*-SS	206	***ASAFHT	90
*AGF*-PV	231	*N-SKIT	175	*WSFP*	209	***ASAFHTSS	90
*AGF*-PV-PS	232	*SFNPCS	84	*WSOF*	206	***DFHT	90
*AGOF*	231	*SFNPSS	84	*WS-RKIT	210	***DFHTSS	90
*AGOF*-PS	232	*SFSK-BAYLAST	84	*WS-SKIT	210	***EFHT	90
*AGOF*-PV	231	*SFSK-TEST	84	**ASAFHT	90	***NP16FHT	90
*AGOF*-PV-PS	232	*SFSK-VI	84	**BOP-SKIT	210	***NP16FHTSS	90
*BOP-SKIT	210	*STBF*	228	**CVVBF**	254	****ASAFHT	90
*CVVBF*	254	*STBF**	228	**CVVDP	255	****DFHT	90
*CVVDP	255	*STBF**_SS	228	**CVVF**	254	****EFHT	90
*CVVF*	254	*STBF*-SS	228	**DFHT	90	****NP16FHT	90
*CVVFM****	254	*STBF*-V2	228	**EF**_B	239	05/062/**/000	277
*CVVOF*	254	*STDP-A	227	**EF**_S	239	08/002/**/00	283
*EBF*-B	239	*STF*	228	**EM**_B	241	08/023/**/000	145
*EF*_B	239	*STF**	228	**E-SKIT	242	08/023/01/047A	145
*EF*_S	239	*STF**_SS	228	**HBF**	190	08/062/**/00	
*EM*_B	241	*STF**_V2	228	**HBF**_B	190	10**	137
*EM*_S	241	*STF*_SS	228	**HBF**_S	190	100-AA-**	29
*ES*_B	242	*STF*_V2	228	**HBF**_SS	190	100-A-HA	15
*E-SKIT	242	*STOF**	228	**HDP-A	188	100-AL-**	26
*HBF*	189	*ST-SKIT	226	**HF**	190	100D-90**	32
*HBF*-B	189	*ST-SKIT-V2	226	**HF**_B	190	100DA-90**	30
*HBF*_S	189	*TDP	234	**HF**_S	190	100-DL-**	26
*HBF*_SS	189	*TRBF*	236	**HOF**	190	100-E-HA	15
*HDP-A	188	*TRBF*_E	236	**KBF**	199	100-F-HA	15
*HF*	189	*TRBF*_E-SS	236	**KF**	199	100-G**	33, 34
*HF*_B	189	*TRBF*_PR	236	**K-SKIT	198	100-G***	33, 34
*HF*_BOP	192	*TRBF*_V	236	**NP16FHT	90	100-G****	34
*HF*_HV	196	*TRBF*_V-SS	236	**STBF**	228	100-G*****	34
*HF*_S	189	*TRDP	237	**STDP-A	227	100-G*****	34
*HF*_SS	189	*TR-SKIT	237	**STF**	228	100GTHK	33
*HF*_SS-BOP	192	*TR-VSKIT	237	**STF**_SS	228	1015-DA-**	30
*HOF*	189	*T-SKIT	234	**STOF**	228	**ST-SKIT	226
*HSBF*-B	194	*VBF*	245	**ST-SKIT	226	**ST-SKIT	226
*HSBF*_S	194	*VBF*_B	245	**STOF**	228	**VBF**	247
*HSF*_S	194	*VBF*_SS	245	**STOF**	228	**VBF**_B	247
*HTBF**	218	*VEPBF*	212	**STOF**	228	**VBF**_SS	247
*HTBF**_SS	218	*VEPDP-A	213	**STOF**	228	**VDP-A	253
*HTDP	218	*VEPF*	212	**STOF**	228	**VEPBF**	212
*HTF*	218	*VEPF*-BOP	215	**STOF**	228	**VEPDP-A	213
*HTF**	218	*VEPOF*	212	**STOF**	228	**VEPE**	212
*HTF**_SS	218	*VF*	245	**STOF**	228	**VEPE**_BOP	215
*HTF*_SS	218	*VF*_B	245	**STOF**	228	**VEPOF**	212
*HTJB*	221	*VF*_B-E	250	**STOF**	228	**VF**	247
*HTM*	220	*VF*_E	250	**STOF**	228	**VF**_B	247
*HTOF*	218	*VF*_SS	245	**STOF**	228	**VF**_B-E	250
*HTOF**	218	*VF*_SS-E	250	**STOF**	228	**VF**_E	250
*HTOM*	220	*VJM*	249	**STOF**	228	**VF**_SS	247
*HTRB*	221	*VM*	248	**STOF**	228	**VF**_SS-E	250
*HT-SKIT	222	*VM*_B	248	**STOF**	228	**VM**	248
*JF*_B	167	*VM*_B-E	252	**STOF**	228	**VM**_B	248
*JM*	168	*VM*_E	252	**STOF**	228	**VM**_SS	248
*JM*_B	168	*VM*_SS	248	**STOF**	228	**VOF**	247
*JS*	169	*VM*_SS-E	252	**STOF**	228	**V-SKIT	253
*JS*_B	169	*VOF*	245	**STOF**	228	**WBF**_B	203
*KDC	198	*V-RKIT	253	**STOF**	228	**WBF**_B-HN	203
		*V-SKIT	253	**STOF**	228	**WDP	201
		*WF*	203	**STOF**	228	**WF**_B	203
		*WF*_B	203	**STOF**	228	**WF**_B-HN	203
		*WF*_B-HN	203	**STOF**	228	**W-RKIT-V2	203
		*W-RKIT	203	**STOF**	228	**WSBF**	206
		*W-RKIT-V2	203	**STOF**	228	**WSBF**_SS	206
		*WSBF*	206	**STOF**	228	**WSDP-A	210
		*WSBF*-BOP	207	**STOF**	228		



1430407KLF	65	2/32-** AL	51	2530-AA-**	29	300-DD-**	29
144****	65	2/38-** AL	51	2530-DA-**	30	300DD-45**	31
144****K	65	2/65-** AL	51	2540-AA-**	29	300DD-90**	31
145****	65	2/90 AL	51	268B****	61	300-DL-**	26
145****K	65	2/A-*** AL	51	27**	137	300E-90**	32
15**	137	2/B-** AL	51	271-****	66	300-E-HA	15
15**-DA-**	28	2/C-** AL	51	271****C	66	300F-90SS	32
150A-90**	31	2/D-** AL	51	272****C	66	300-F-HA	15
150-AA-**	29	20**	137	272****CBC	66	300-G**	33, 34
150-A-HA	15	20**-DA-**	28	272****SS	66	300-G***	33, 34
150-AL-**	26	200A-90**	31	273-****	67	300-G****	34
150B-90**	31	200-AA-**	29	273****C	67	300-G-****	34
150C-90**	32	200-A-HA	15	274****C	67	300GTHK	33
150D-90**	32	200-AL-**	26	274****CBC	67	300GTHKBF	34
150DA-90**	30	200-AL-SSANSI	26	275	110, 147	300-LH-BR	36
150-DL-**	26	200B-90**	31	278****C	68	300PRSCSS	37
150-E-HA	15	200C-90**	32	2789***CBC	68	3015-DA-**	30
150F-90AL	32	200D-90**	32	280-****	68	3015-F-**	28
150-F-HA	15	200DA-45**	30	280****C	68	3020-*ALA	27
150-G-**	33, 34	200DA-90**	30	280****CBC	68	3020-*SSA	27
150-G-***	33, 34	200-DD-**	29	296****C	68	3020-C-**	27
150-G-****	34	200DD-45**	31	296****CBC	68	3020-D-**	27
150-G-****	34	200DD-90**	31	296****SS	68	3020-DA-**	30
150GTHK	33	200-DL-**	26	2DB*-B	183	3020-E-**	28
1510-*ALA	27	200E-90**	32	2DBF*-B	182	3020-F-**	28
1510-*SSA	27	200-E-HA	15	2DBM*-B	184	3025-DA-**	30
1510-D-**	27	200F90AL	32	2DF*-B	182	3040-*ALA	27
1510DAAL	30	200F-90SS	32	2DF*-S	182	3040-*SSA	27
1510-DA-SS	30	200-F-HA	15	2DM*-B	184	3040-AA-**	29
1520-AA-**	29	200-G-**	33, 34	2DM*-S	184	3040-C-**	27
1520-DA-**	30	200-G-***	33, 34	2DS*-B	185	3040-DA-**	30
1520-F-**	28	200-G-****	34	2DS*-S	185	3040-DD-**	29
156	110, 147	200-G-****	34	2FBF*-B	182	3040-F-**	28
16P*	129	200GTHK	33	2FBM*-B	184	305	137
17**	137, 148	200-LH-BR	36	2FF*	182	306	110, 147
1765A	58	200PRSCSS	37	2FF*-B	182	3060-DA-**	30
177-****	63	200YDAAAL	29	2FF*-S	182	30P*	179, 180
177****C	63	2010-DA-**	30	2FM*	184	30S*	179, 180
177****SS	63	2015-*ALA	27	2FM*-B	184	34**	137
177****SS	63	2015-*SSA	27	2FM*-S	184	350	110, 147
178****C	95	2015-C-**	27	2FS*	186	37**	137
179-****	64	2015-D-**	27	2FS*-B	186	3701212C	55
179****C	64	2015-DA-**	30	2FS*-S	186	375	110, 147
179****SS	64	2015-E-**	28	2FS2.5-B	186	3AGF3-PS	232
179****SS	64	2015-F-**	28	2HDP-H*DC	188	3AGF3-PV-PS	232
1790604BARB	64	2025-DA-**	30	2TM*	233	3DB*-B	183
180****F	71	2030-*ALA	27	3/**-*** AL	50	3DBF*-B	182
180****FSS	71	2030-*SSA	27	3/32-*** AL	50	3DBM*-B	184
182****S	71	2030-AA-**	29	3/38-*** AL	50	3DF*-B	182
182****SS	71	2030-DA-**	30	3/65-*** AL	50	3DF*-S	182
183****K	69	2030-DD-**	29	3/90-*** AL	50	3DM*-B	184
183****KSS	69	2030-F-**	28	3/A-*** AL	50	3DM*-S	184
184****A	70	2040-DA-**	30	3/B-*** AL	50	3DS*-B	185
185-****	70	206		3/C-*** AL	50	3FBF*	182
185****K	70	20P*		3/D-*** AL	50	3FBM*	184
187	110, 147	20S*		30** -DA-**	28	3FF*	182
187****	70	212		300A-90**	31	3FF*-S	182
187****K	70	22**	137	300-AA-**	29	3FM*	184
19**	137	225		300-A-HA	15	3FM*-S	184
1PDF*	256	23**	137	300-AL-**	26	3FS*	186
1PDM*	257	250		300-AL-SSANSI	26	3FS*-S	186
		250-AA-**	29	300B-90**	31	3NBM*	172
2/100 AL	51	250-G-**		300C-90**	32	3NCS4	173
2/125 AL	51	250-G-***		300D-90**	32	3NM*	172
2/135-*** AL	51	250-G-****	34	300DA-45**	30	3TBM*	233
2/150-*** AL	51	250GTHK	33	300DA-90**	30	3TF*	233
2/165-*** AL	51	2520-DA-**	30			3TM*	233



3TM*-SS-PV .....	234	4FS*-S .....	186	675 .....	148	AG*BF* .....	232
3TM3-** .....	234	4HDP-H*DC .....	188	6DF*-B .....	182	AG*BF*-PV .....	232
4*** .....	140	4K*-DP .....	198	6DM*-B .....	184	AG*DC .....	231
4/32-*** AL .....	50	4N4N .....	174	6DS*-B .....	185	AG*F* .....	232
4/38-*** AL .....	50	4NBF* .....	170	6HDP-H*DC .....	188	AG*F*-PV .....	232
4/B-*** AL .....	50	4NBF*-B .....	170	6P* .....	129	AG*OF* .....	232
4/C-*** AL .....	50	4NBM* .....	172	7/***-B AL .....	52	AG*OF*-PV .....	232
4/D-*** AL .....	50	4NBM*-B .....	172	7/**-B AL .....	52	AH***EZ .....	21
4/D-32-*** AL .....	50	4NF* .....	170	7/**-C AL .....	52	AKSP1 .....	43
4/DA*** AL .....	50	4NF*-B .....	170	7/125-A AL .....	52	AKSP25 .....	43
40**-DA** .....	28	4NF*-S .....	170	7/150-A .....	52	ALC* .....	98
400 .....	148	4NM* .....	172	7/A-*** AL .....	52	ALCS* .....	100
400A-90** .....	31	4NM*-B .....	172	7/A-B AL .....	52	ALDC***DC .....	164
400-AA-** .....	29	4NM*-S .....	172	7/B-** AL .....	52	ALDC***DP .....	163
400-AL-** .....	26	4NS* .....	173	7/B-C AL .....	52	ALF* .....	98
400C-90** .....	32	4NS*-B .....	173	7/C-** AL .....	52	ALFB* .....	100
400D-90** .....	32	4NS*-S .....	173	7/C-D AL .....	52	ALFW* .....	99
400DA-45** .....	30	4NS*-WF*3 .....	175	709 .....	137	ALM* .....	98
400DA-90** .....	30	4P* .....	129	750 .....	109, 147	ALMB* .....	100
400-DD-** .....	29	4P-CLIP .....	178	75-G** .....	33, 34	ALMF*D .....	99
400DD-45** .....	31	4PF* .....	176	75-G-*** .....	33, 34	ALMF*E .....	99
400DD-90** .....	31	4PF6-B .....	176	75-G-**** .....	34	ALMF*NP16 .....	99
400-DL-** .....	26	4PF6-S .....	176	75-G-***** .....	34	ALMW* .....	99
400E-90** .....	32	4PM* .....	177	769 .....	148	ALO* .....	99
400-G** .....	33, 34	4PM6-9 .....	177	8/** AL .....	51	AM* .....	55
400-G-*** .....	33, 34	4PM6-S .....	177	8/*** AL .....	51	AM**WF .....	44
400-G-**** .....	34	4PS* .....	178	8/A AL .....	51	AM**WF-1 .....	44
400GTHK .....	33	4PS*-B .....	178	8/B AL .....	51	AM*SWIV .....	45
400GTHKBF .....	34	4PS4-WF43 .....	178	8/C AL .....	51	AM*WF .....	44
400-LH-BR .....	36	4PS6-9 .....	178	8/D AL .....	51	ASFI25T*** .....	160
401 .....	110, 147	4PS6-WF63 .....	178	800-AL-** .....	26	ASFI30T*** .....	160
4020-DA-** .....	30	4P-SKIT .....	178	800-DL-** .....	26	AST* .....	88
4025-DA-** .....	30	500-G-** .....	33, 34	800-G** .....	33	AST** .....	88
4030-*ALA .....	27	500-G-*** .....	33, 34	8060-DA-** .....	30	AWR4 .....	43
4030*-SSA .....	27	5030-DA** .....	30	811 .....	137	AWR4V .....	43
4030-C** .....	27	5040-*AL .....	27	818 .....	148	AWS6 .....	43
4030-D** .....	27	5040-DA** .....	30	850 .....	109, 147	B* .....	146
4030-DA** .....	30	5040-E** .....	28	850*** .....	134	B** .....	146
4030-E** .....	28	5060-DA** .....	30	855 .....	57	B**SC .....	107
4030-F** .....	28	507 .....	137	855A .....	57	B**SC .....	55
4050-AA** .....	29	50-G** .....	33, 34	856* .....	57	BA* .....	105
4050-DA** .....	30	50-G-**** .....	34	856-** .....	57	BB* .....	146
4060-*ALA .....	27	5111A .....	58	861-** .....	57	BB* .....	109
4060*-SSA .....	27	519** .....	144	875 .....	148	BB** .....	110
4060-AA** .....	29	525 .....	148	8HDP-H*DC .....	188	BB***EZ .....	21
4060-DA** .....	30	550 .....	148	8P* .....	129	BB3WL*** .....	273
40P* .....	179, 180	59-*** .....	295	968 .....	110, 147	BB3WL***B .....	273
40S* .....	179, 180	595****K .....	71	988 .....	148	BBFVW*** .....	284
418 .....	110, 147	6**** .....	295	A* .....	45, 148	BBFVW***E .....	284
431 .....	148	60**-DA** .....	28	A** .....	45, 148	BBLV** .....	55
450 .....	110, 147	600 .....	148	A100C**A .....	87	BBU* .....	109
463 .....	148	600-AA** .....	29	A7** .....	266	BBU* .....	146
4DB*-B .....	183	600-AL** .....	26	A7*** .....	266	BBU** .....	146
4DBF*-B .....	182	600C-90** .....	32	AB* .....	41-43	BBV***LV .....	268
4DBM*-B .....	184	600D-90** .....	32	AB** .....	41-43	BBV***SR .....	270
4DF*-S .....	182	600DA-45** .....	30	AC* .....	43	BBV**ST .....	268
4DM*-B .....	184	600-DL-** .....	26	AC***EZ .....	21	BBV**LV .....	268
4DM*-S .....	184	600-G** .....	33, 34	AC7 .....	38	BBV**SR .....	270
4DS*-B .....	185	600-G-*** .....	33, 34	ACL* .....	37	BBV**ST .....	268
4FBF* .....	182	600-LH-BR .....	36	ACL8 .....	43	BC***EZ .....	21
4FBM* .....	184	6030-DA** .....	30	AD***EZ .....	21	BCK-**** .....	287
4FF* .....	167, 182	6040*-SSA .....	27	AD90400** .....	32	BD .....	146
4FF*-S .....	182	6040-DA** .....	30			BD***EZ .....	21
4FM* .....	168, 184	6050-DA** .....	30			BF** .....	62
4FM*-S .....	184	639 .....	148			BF*** .....	58
4FS* .....	169, 186						

BF***	62	CH-C-12	38	D6S*	186	E**M**	241
BF**SS	62	CH-SS-**	38	DAA***AL	161	E**M**-B	241
BFL***	59	CH-SS-6	38	DAA***ALFL	161	E*BF*-B	240
BFM***	59	CS***	144	DAC***AL	160	E*F*	240
BFM***B	59	CS100-***S	114	DAC***ALBSP	160	E*F*-B	240
BFMW****	58	CS100-**S	114	DAD****	160, 161	E*F*-S	240
BFS**	62	CS125-**S	114	DADC250	161	E*M*	241
BFS***	62	CS150-***S	114	DB**	106	E*M*-B	241
BFVL***	284	CS150-**S	114	DBA**.*	164	E*M*-S	241
BFVL***E	284	CS200-***S	114	DBAV73-2030	164	E*S*	242
BFVW***	284	CS200-**S	114	DBC**.*	163	E*S*-B	242
BFW***	58	CS300-***S	115	DBC77-***-GL	163	EL**H*M	63
BFW****	58	CS300-**S	115	DBCL-***	163	EL*H*M	63
BGV**	277	CS400-***S	115	DBS**-200	163	EL*H*MSS	63
BGV***	277	CS400-**S	115	DBV-BL***	264	ELOK***	277
BH***EZ	21	CS600-**S	115	DBV-BN***	264	F***	143
BLCA152CS	38	CSN75	86	DBV-WB***	264	F**-E-SKIT	242
BLS***	71	CVF-1161-***	288	DD	146	F*-E-SKIT	242
BN**	61	CVF-1161-****	288	DDA***AL***TTMA	159	F1	144
BN***	61	CVV**BF**	255	DDA***ALFL	159	F-4N-SKIT	175
BN***RU**	69	CVV**DC	255	DDA***BR	159	F-4P-SKIT	178
BN***RU**SS	69	CVV**F**	255	DDA***BRFL	159	FBV**	268
BN**BSPT	61	CVV*BF*	255	DDA***GM	159	FBV***	268
BN**RU**	69	CVV*DC	255	DDA***GMFL	159	FBV**B	268
BN**RU**SS	69	CVV*F*	255	DDA***SS	159	FBV**B	268
BPF**	67	CVV*FM****	255	DDA***SSA	159	FBV**B	268
BPF***	67	D*	109	DDA***SSFL	159	FBVL**	269
BPFS**	68	D**	55	DDA300**105	159	FBVL***	269
BPM*	68	D2BF*	183	DDA300**105FL	159	FBVL***B	269
BPM**	68	D2BM*	185	DDC***AL	158	FBVL**B	269
BPN**	66	D2F*	183	DDC***ALA	158	FF**/CS	48
BPN***	66	D2F*-B	183	DDC***BR	158	FF**/SS	48
BS**	109	D2F*-S	183	DDC***GM	158	FF100/CS	48
BST*	88	D2M*	185	DDC***SS	158	FF100/SS	48
BST**	88	D2M*-B	185	DDC***SSA	158	FFB***	291
BU*	109	D2M*-S	185	DDC300***105	158	FFB**B	291
BU*	146	D2S*	186	DDC300**105	158	FFC***	291
BU**	146	D2S*-S	186	DDDC***	159	FFC**B	291
C*	144	D2S2.5	186	DDDC*****	159	FFS***	291
C**	260	D3BF*	183	DDDP***	158	FFS**B	291
C***	260	D3BM*	185	DDDP*****	158	FFS-RGLUBE	266
C***BU	260	D3F*	183	DDSA***SS	161	FKG-VK	282
C**BU	260	D3F*-B	183	DDSC***SS	161	FLOBOSS-050	86
CAL**	37	D3F*-S	183	DFVS**	96	FS*	142
CAMOPENER	38	D3M*	185	DGA***SS	162	FS**	142
CCF****	44	D3M*-B	185	DGA***SSFL	162	FS***	142
CD	45, 146	D3M*-S	185	DGA100SS175	162	FS**/CS	48
CF100-***S	116	D3S*	186	DGA200SS325	162	FS**/CS	48
CF100-**S	116	D3S*-B	186	DGC***SS	162	FS**/SS	48
CF125-**S	116	D3S*-S	186	DGD****	162	FS100/SS	48
CF150-***S	116	D4BF*	183	DGLBV**	289	FSBVB-***	271
CF150-**S	116	D4BM*	185	DGLBV***	289	FSBVN-***	271
CF200-***S	116	D4F*	183	DGLBV**B	289	FSCV**	287
CF200-**S	116	D4F*-B	183	DGLBV**B	289	FSCV***	287
CF300-***S	117	D4F*-S	183	D-H*F*-S	196	FSCV**B	287
CF300-**S	117	D-4HF4-S-FNS	195	D-H*F*-SS	196	FSCV**B	287
CF400-***S	117	D-4HF4-S-FSB	195	DL**	148	FSGLBV**	289
CF400-**CSHD	118	D-4HF4-SS-FNS	195	DL***	148	FSGLBV***	289
CF400-**S	117	D-4HF4-SS-FSB	195	DM*	94	FSGLBV**B	289
CF400-*CSHD	118	D4M*	185	DM**	94	FSGLBV**B	289
CF600-***S	117	D4M*-B	185	DM***	94	FSGVB-***	278
CFS800-*CS	73	D4S*	186	DMXL**	94	FSGVN-***B	278
CFS800-*CS	120	D4S*-B	186	DST**	97	FST**CS	119
CG***	144	D4S*-S	186	E**F**	240	FVS***CI	96
CH-B-12	38	D6F*	183	E**F**-B	240	FVS***EU	96
CH-B-6	38	D6M*	185	E**F**-S	240	G*****HRPSS	36

G****-00	295	GF*	103	HA11**T	127	IXF16-*	133
G****E	265	GF**	103	HA110*	127	IXF20-*	133
G****T	266	GF***	103	HA115*	131	IXF24-*	133
G****V	265	GF***A	103	HA117*	123	IXF32-*	133
G***-A-**	9	GF***P*	107	HAB***EZ	15	IXF40-*	133
G***-A-**B	9	GF**A	103	HAC***EZ	15	IXF48-*	133
G***-B-**	9	GF**P*	107	HAD***EZ	15	IXF64-*	133
G***-B-**B	9	GF*A	103	HB****	55	J**	148
G***BL	264	GFAS*	107	HB****G	55	J***	38
G***-C-AL	10	GFAS**	107	HS*	138	J*F*	168
G***-C-ALCR	17, 113	GL***	55	HS**	138	J*F*-B	168
G***-C-BRCR	17, 113	GM*	104	HS***	138	J*M*	169
G***-C-SSCR	17, 113	GM**	55	HS*BF*	194	J*M*-B	169
G***-D-**	10	GM**A	104	HS*BF*-S	194	J*S*	169
G***-D-**B	10	GM*A	104	HS*F*-B	194	JX**	148
G***-DC-**	12	GMAS*	107	HS*F*-S	194	K**BF**	200
G***-DP-**	12	GMAS**	107	HSS*	138	K**F**	200
G***E	265	GSAFETYCLIP	36	HSS**	138	K*F*	200
G***-E-**	11	GV***BH	277	HSS***	138	K*OF*	200
G***-E-ALCR	17, 113	GVNR-RW-1161-**	280	HT*BF**	219	K4*-DC	198
G***-E-BRCR	17, 113	GVNR-RW-1161-***	280	HT*BF**-SS	219	KM**	95
G***-E-SSCR	17, 113	GVRC1161-***	279	HT*BF*-SS	219	KM***	95
G***-F-**	11	GVRC1161-****	279	HT*DC	218	KRW*	92
G***-F-**B	11	H**	259	HT*F*	219	KRW**	92
G***HRP	36	H***	259	HT*F**-SS	219	KS*	142
G***HRPSI	36	H***BU	259	HT*F*-SS	219	KS**	142
G***HRPSS	36	H**BF**-B	190	HT*JB*	221	KS***	142
G***N	264, 266	H**BF**-S	190	HT*M*	220	KSF***B	91
G***T	264, 266	H**BF**-SS	190	HT*OF*	219	KSF***M	91
G***V	265	H**BU	259	HT*OF**	219	KSF***SS	92
G***VB	264	H**DC-A	188	HT*OM*	220	KSM***B	91
G**-A**	9	H**F**	190	HT*RB*	221	KSM***M	91
G**-A**B	9	H**F**-B	190	HT*-SKIT-V2	222	KSM***SS	92
G**-B**	9	H**F**-S	190	HTE*BF*	225	KSS**	53
G**-B**B	9	H*BF*	191	HTE*F*	225	KSW**	53
G**-C**	10	H*BF*.B	191	HTE*OF*	225	L**	261
G**-D**	10	H*BF*.S	191	HTM***L	139	L***	261
G**-D**B	10	H*BF*-SS	191	HU*****BW	78	L***BU	261
G**-DC**	12	H*DC	257	HU*****BW	78	L***-C-SS	16
G**-DP**	12	H*DC-A	188	HU*****N	75	L***-DC-SS	16
G**-E**	11	H*F*	191	HU*****RN	75	L***-DP-SS	16
G**-F**	11	H*F*-B	191	HU100***	77	L***-E-SS	16
G**-F**B	11	H*F*-BOP	192	HU100***	78	L***-HSCRIP-SI	16
G**HRP	36	H*F*-HV	196	HU100***BW	77	L**-A-SS	16
G**HRPSI	36	H*F*-S	191	HU150****	78	L**BU	261
G2***SS	272	H*F*-SS	191	HU200***	77	L0*BL	264
G2/**SS-NPT	272	H*F*-SS-BOP	192	HU206***	77	LM**	129
G3/**SS	272	H*OF*	191	HU602***	78	LR*	43
G3/**SS-NPT	272	HA0***	123-132	HUC207400	76	LRHEZ**	16
G75HRPSS	36	HA0***TZP	123-132	HUF206400FLG	76	LRHEZ***	16
GAM*	41, 42	HA0***ZP	123-132	HUF206400FLG-45	76	LS**	140
GAM**	41, 42	HA00**	124	HUF206400FLG-ST	76	LS***	140
GAM**A	42	HA01**TZP	127	HUM206400FLG	76	LSS**	140
GAM*A	42	HA01**ZP	127	HUM206400FLG-45	76	LSS***	140
GAMB	42	HA010*	127	HUM206400FLG-ST	76	M*	94, 108
GAMB*	42	HA014*ZP	133	HUMF206300CS	72	M**	94, 108
GAMC*	42	HA015*ZP	123	HUMF206400CS	72	MAH*	139
GAS****NO	22	HA016*ZP	123	HUMF206600CS	72	MAH**	139
GAS****NOS	23	HA017*ZP	123	HUMF206800CS	72	MB**SS	48
GB*	103, 104	HA019*ZP	125	HUP207400	76	MBV**	269
GB**	103, 104	HA0900-*	76, 125	HUSF500SW	73	MBV**B	269
GB**A	104	HA1***	123-131	IBFVW***	284	MC***	292
GCA	103	HA1***T	123-131	IBFVW***E	284	MC**B	292
GCC	104	HA10**	123-131				
GCCA	104	HA11**	123-131				
GDB*	104						
GDB**	104						

MFB***	291	N4S*-B-LS	174	RDM*	94	SC***	150
MFB***B	291	N4S*-LS	174	RDM**	94	SC**X10AL	93
MFC***	291, 292	N4S*-S	174	RE***EZNO	22	SC**X10SS	93
MFC****	291	N4S*-WF*3	175	RE075-1***	23	SC**X12AL	93
MFC****B	291	N4S6-S-LS	174	RE100-1***	23	SC**X6.5AL	93
MFC***B	291	P**	60	REBCB	93	SC**X6.5SS	93
MFC***B	291, 292	P**E-SKIT	242	REF***B	93	SC**X6AL	93
MFS***	291, 292	P*E-SKIT	242	REHE***B	93	SC**X6SS	93
MFS****	291	P4F*	177	RESG	93	SC**X7.5AL	93
MFS***B	291	P4F*-B	177	RFST**CS	119	SC**X7.5SS	93
MFS***B	291, 292	P4F6-9	177	RGF**P*	107	SC**X8AL	93
MGB**	49	P4F6-S	177	RH***EZ	21	SC**X8SS	93
MGB100	49	P4M*	177	RHEZ**	36	SCCW***	150
MH*	139	P4M*-B	177	RHEZ**	36	SCCW****	150
MH**	139	P4M6-9	177	RHS*	294	SCF13x6BR	111
MK**BR	48	P4M6-S	177	RHS**	294	SCF19x7BR	111
MK**SS	48	PD1F*	256	RHS**	96	SCF25x7.5BR	111
MK100BR	48	PD1M*	257	RHS***	294	SCM13x6BR	111
MK100SS	48	PD1OM*	257	RHS***	96	SCM19x7BR	111
MKLR**BR	49	PL***	56	RKHN***	61, 90	SCM25x7.5BR	111
MKLR**SS	49	PL***L	56	RL**V	262	SCV***	290
MKLR100BR	49	PPA***B	13	RLC***EZ	16	SCV****	290
MKLR100SS	49	PPB***B	13	RLH***EZ	16	SCV***X25CW	290
MKSR**BR	49	PPC***B	13	RM*	95	SCV***X25YV	290
MKSR**SS	49	PPD***B	13	RMS*	108	SCVH*	286
MKSR100BR	49	PPE***B	14	RMS**	108	SCVH**	286
MKSR100SS	49	PPF***B	14	RMS**A	108	SCVH**BSP	286
MS*	108	PPH***B	14	RMS*A	108	SCVH*BSP	286
MS**	108	PPP***B	14	RN**	61, 90	SCVJ*	286
MS***	292	PTLS10040	295	RN***	61, 90	SCVJ*BSP	286
MS***B	292	PTLS7540	295	RN**CS	119	SCVL*	286
MS**A	108	PYLS****	295	RPN**	66	SCVL**	286
MS**X*	108	PYLS*****	295	RRHS**	96	SCVL**BSP	286
MS**X**	108	QDF**M	46	RRHS**	294	SCVL*BSP	286
MS**X**A	108	QDF100M	46	RSS**	294	SCVM*	286
MS**X*A	108	QDHE**M	46	RSS**	97	SCVM**	286
MS*X*	108	QDHE100M	46	RST*	88	SCVM**BSP	286
MS*X**	108	QDM**M	46	RST**	88	SCVM*BSP	286
MS*X**A	108	QDM100M	46	RST***NOS	23	SCVR*	286
MSBC***SS	154	R**	60, 263	RST***NOSA	23	SCVR*BSP	286
MSBC***SSA	154	R***	263	RST**A	88	SCVS*	55, 286
MSBC***SSFL	155	R**BU	263	RST**CS	118	SCVS**	286
MSBC***SSMBSP	154	R**BU	263	RST**CSA	118	SCVS**BSP	286
MSBC***SSMNPT	154	R200SS	38	RST*A	88	SCVS*BSP	286
N**CS	119	RAM*	41-43	RSTB*	89	SD*200	37
N3BM*	172	RAM**	41, 42	RSTB**	89	SD*300	37
N3CS4	174	RAM**WF	44	RSTB**CS	119	SD*400	37
N3M*	172	RAM*WF	44	RSTB**-M	89	SE45***	55
N4BF*	171	RB*	109	RSTV**CS	119	SF**/BR	47
N4BM*	172	RB*	146	S***X***X***CS	120	SF**/SS	47
N4BM*-B	172	RB**	105, 110 146	S***X***X120CS	74	SF*20FGXFGCS00	84
N4BM*-LS	173	RB***EZ	21	S***X***X***CS	120	SF*20FGXFGCS10	84
N4DC	175	RB***EZA	21	S***X***X090CS	74	SF*20WXWCS00	84
N4DC-B	175	RBU*	146	S***X***X120CS	74	SF*20WXWCS10	84
N4F*	171	RBU*	109	SBC***AL-DE	152	SF100/BR	47
N4F*-B	171	RBU**	109	SBC***ALA-DE	152	SF100/SS	47
N4F*-B-LS	171	RC***EZ	21	SBC***ALFL-DE	153	SG***	144
N4F*-S	171	RC***EZ-70	23	SBC***ALMBSP-DE	152	SHS**	96
N4M*	172	RC***EZCR	17	SBC***ALMNPT-DE	152	SHS**	294
N4M*-B	172	RC***EZNO	22	SBC***SS-DE	152	SHS***	294
N4M*-B-LS	173	RC100EZ	21	SBC***SSA-DE	152	SK1098	137
N4M*-LS	173	RD***EZ	21	SBC***SS-CR-DE	156	SLS***	71
N4M*-S	172	RD***EZA	21	SBC***SSFL-DE	153	SM**/BR	47
N4M6-S-LS	173	RDL***EZ	26	SBC***SSMBSP-DE	152	SM**/SS	47
N4S*	174			SBC***SSMNT-DE	152	SM100/BR	47
N4S*-B	174			SC**	141	SM100/SS	47
						SN75	86

SRV-***	293	TR*BF*-E	236	VEP*BF*	213
SS***	144	TR*BF*-E-SS	236	VEP*DC-A	213
SS3PFSB-***	271	TR*BF*-PR	236	VEP*F*	213
SS3PFSN-***	271	TR*BF*-V	236	VEP*F*-BOP	215
SS3WL***	273	TR*BF*-V-SS	236	VEP*OF*	213
SS3WL***B	273	TR*DC	237	VFBFW-***-GEAR	285
SSBV**	272	TS**T	49	VF-GVNR-RW-****	281
SSBV***	272	TS100T	49	VF-PI	281
SSBV***B	272	TSC**	47	VG172-OSY***	278, 280
SSBV**B	272	TSC****	47	VG172-OSY****	278, 280
SSC-***	287	TSK34	47	VG172-OSY****ATS	278, 279
SSGV**	277	TSS**	97	VG172-OSY***ATS	278
SSGV***	277	TSS**	294	VG172-OSYE***ATS	279
SSGV***B	277	TWHS**	49	VGA-150-***	280
SSGV**B	277	TWHS100	49	VGA-CS-150-***	281
SSPM*	68	UL***	143	VGBBF**-GEAR	285
ST**BF**	229	UL****	143	VGBFHP-***	285
ST**DC-A	227	ULM***	143	VGBFHP-***-GEAR	285
ST**F**	229	V**BF**	247	VGBFHP**-GEAR	285
ST**F**-SS	229	V**BF**-B	247	VK**BR	48
ST**OF**	229	V**BF**-SS	247	VK**SS	48
ST*-SKIT	227	V**DC-A	253	VK100BR	48
ST*BF*	229	V**F**	247	VK100SS	48
ST*BF**	229	V**F** B	247	VKG-***	282
ST*BF**-SS	229	V**F** B-E	251	VKG-***-SS	282
ST*BF*-SS	229	V**F** E	251	VR-268-**	293
ST*DC-A	227	V**F**-SS	247	VSC-150-***	288
ST*F*	229	V**F**-SS-E	251	W**	106
ST*F**	229	V**M**	248	W**BF**-B	204
ST*F**-SS	229	V**M**-B	248	W**BF**-B-BMF	204
ST*F*-V2	229	V**M**-E	252	W**DC	201
ST*F*-SS	229	V**M**-SS	248	W**F**-B	204
ST*F*-V2	229	V**M**-SS-E	252	W*-RKIT-V2	203
ST*OF*	229	V**OF**	247	W*BF*-B-BMF	204
ST*OF**	229	V*BF*	246	W*-BMF	204
ST*-SKIT	227	V*BF*.B	246	W*F*	204
STB**	89	V*BF*.SS	246	W*F*-B	204
STB***	89	V*DC-A	253	W*-RKIT-V2	203
STB**CS	119	V*F*	246	WA*	54
STB**-M	89	V*F*-B	246	WB*	54
STC*	88	V*F*-B-E	251	WBC	106
STC**	88	V*F*-E	251	WBN***	55
STC***	88	V*F*-SS	246	WF*	105
STC***A	88	V*F*-SS-E	251	WF**	105
STC**A	88	V*JM*	249	WF***	105
STC**CS	88, 118	V*M*	248	WH***-A	37
STC**CSA	118	V*M*-B	248	WH***-G	37
STC*A	88	V*M*-B-E	252	WS**BF**	208
STV**	89	V*M*-E	252	WS**DC-A	210
STV***	89	V*M*-SS	248	WS**F**	208
STV**CS	119, 120	V*M*-SS-E	252	WS**F**-BOP	208
STV**-M	89	V*OF*	246	WS*DC-A	210
STVS***	89	V*-RKIT	253	WS*F*	208
STVS**CS	119	V2F-150-***	270	WS*F*-BOP	208
STVS**-M	89	V2F-150DR-***	270	WSR*	54
STZSPAN*.*	52	V2FH-***	270	Y***	295
SV***	55	V57SV-**	282		
SWCV**	286	V57SV-***	282		
SWCV***	286	V57SVHW-***	282		
T*BF*	234	VB**SS	48		
T*DC	234	VEP**BF**	213		
T*F*	234	VEP**DC-A	213		
T3F3-**	234	VEP**F**	213		
T3F3-SS-PV	234	VEP**F**-BOP	215		
TCS***	96	VEP**OF**	213		
TR*BF*	236				

## Description Index

### A

Agri-Lock Bauer couplings .....	98-100
Air	
Check valves.....	286
Receiver manifold, ASME .....	55
Air fittings	
DF-series pneumatic couplings.....	181-186
J-series pneumatic couplings.....	167-169
NK-series pneumatic couplings .....	179, 180
N-series pneumatic couplings.....	170-175
P-series pneumatic couplings .....	176-178
Air King™ .....	41. <i>See also</i> Claw Couplings
Ferrules.....	44
Air line	
Shut-off valves .....	286
Air lubricators .....	56
ASME air receiver manifold .....	55

### B

Ball valves. <i>See</i> Valves	
Band and buckle clamps.....	142-144
Band clamp tools .....	143
Bendigo valve .....	277
Boss	
Clamps.....	109
Boss fittings.....	101-110
Adaptors.....	107
Hammer unions.....	77, 78
Hose mender .....	94, 108
Male stem .....	108
Washer seal .....	105, 106
Wing nut caps .....	107
Boss LPS	
Frac fittings .....	72, 73
Hammer union caps and plugs .....	76
One-piece flange adaptors.....	76
One-piece hammer union nuts.....	75
Two-piece hammer union nuts.....	75
Vent-Lock™ cam & groove couplings.....	16
Boss™	
Clamps.....	146
Brass	
Barbed hose fittings .....	61-68, 90
Boss™	
Clamps .....	146
Ferrules.....	71
Garden hose fittings.....	71
GEKA.....	93
Push-on fittings .....	66-68
Reusable fittings .....	69-71
Swivels.....	62, 65, 66, 68, 70

Brass ferrules.....	58, 59
Crimping tools .....	57
Brass fittings .....	58, 59

### C

Cam & groove	
150# flange .....	26
Adaptors.....	26
150# ANSI flange.....	26
Adaptor x 150# flange .....	26
Clips.....	37, 38
Couplers.....	26, 36
150# flange.....	26
Coupler x 150# flange .....	26
Coupler x adaptor wye.....	29
Elbows	
45° adaptor x coupler .....	30
45° coupler x coupler .....	31
90° adaptor x coupler .....	30
90° coupler x coupler .....	31
90° type A adaptor x female NPT .....	31
90° type B coupler x male NPT .....	31
90° type D coupler x female NPT .....	32
90° type E adaptor x hose shank .....	32
90° type F adaptor x male NPT .....	32
EZ Boss-Lock™ .....	20-23, 26
Flanged .....	26
Gaskets.....	33-35
Global.....	36
Handle assemblies.....	36
Handles	
Global .....	36
Specialty	
Reducing adaptors & couplers .....	27, 28
Smooth tail stainless steel.....	93
Spool adaptors & couplers .....	29
Specifications.....	8, 355
Standard BSP .....	13
Vent-Lock™ .....	16
Check valves	
Swing .....	286
Chicago fittings (Air King™).....	41-45
Chicago type fittings.....	44, 55
Clamps	
2, 4 & 6-Bolt .....	47, 109, 110
Band and buckle .....	142-144
Boss™ .....	146
Centre punch .....	142
European compressor.....	47
Kits.....	140
Painted iron.....	264
Gaskets .....	264
Pinch-On.....	137
Safety claw clamps .....	145
Spiral clamps .....	150
Ultra-Lok® .....	143
Worm gear .....	138
Make-a-clamp kits .....	140

Claw couplings	
Air King™	41-45
Specifications	356
Combination nipples	88-90
Composite hoses	305
Couplings	
Cam & groove	36
Lightweight flexible	261
Lite®	262
Quick release	259
Rigid	263
Standard	260
Crimping	
External	127
Crimping tools	57
Crimp recommendation guide	365
Crows foot	<i>See</i> Claw Couplings

## D

DIX lock couplings	174
Dry disconnect fittings	
Bayonet style	165
Dry aviation couplings	160, 161
Dry break cam & groove	163, 164
Dry gas couplings	162
Dry quick disconnect adaptor	159
Dry quick disconnect coupler	158
Safety break away couplings	152, 154, 155, 156
Dubl-Grip®	134
Dust caps	12, 14, 21

## E

Econovalves™	274-276
Elbows	
Cam & groove	30-32
Hose barb	63, 64, 67
Splicer	63
Engineered fluid transfer	
ADS	87
Outalarms	87
with capacitance probe	87
European compressor	
Clamps	47
Couplings	46
EZ Boss-Lock™	26

## F

Ferrules	
Brass	71
Global Air King™	44
Ferrules, brass	58, 59
Finger type clamps	146
Flanged	
Cam & groove	26

Flow Boss™ spray gun	86
Flushface interchange couplings	216, 217
Frac fittings	72, 73

## G

Garden hose	
Shank fittings	71
Gaskets	
Cam & groove	33, 34
GEKA	93
Glossary of terms	379, 380
Grooved fittings	264
Clamps	264
Gaskets	264
Gaskets	265, 266
Lightweight	261
Quick release	259
Rigid	263
Series AN	266
Standard	260
Ground joints	103-105

## H

Hammer unions	75-78
Hand-built hoses	305
Handles, cam & groove	36
Holedall™ fittings	135
External crimp	126
External crimping	127
External swaging	122, 123, 125
High pressure couplings	129
Uni-range couplings	129
Internal expansion	130, 131, 133
Ferrules	133
Stems	131
Working pressures	135
Horizontal swing check valves	286
Hose	
Composite	305
Fittings, barbed	61-68, 90
Hand-built	305
Menders	95
Metallic	304
PTFE	304
Rubber	305
Specialist and bespoke	306
Spiral PVC	305
Hose assemblies	304-306
Metallic	304
PTFE	304
Hose assemblies technical	308, 310-312, 320-323, 325
Be safe	308
Hose and coupling safety	311
Pressure recommendation chart	322-325
Hose crimper	57

Hose fittings and couplings tech .....	308, 310-312, 341-347, 355-363
Boss™ fittings and clamp specs	357, 358
Cam & groove	
Nominal take-up lengths .....	355
Specifications .....	355
Claw coupling specifications .....	356
Corrosion resistance .....	341-347
Crimped Air King™ specifications .....	359, 360
Hose joiners	
Boss hose mender .....	94, 108
Hose technical .....	326-338
Basic compounds in rubber hose .....	327
Bend radius recommendations .....	326
Flow rate of water through hose	329
Pressure drop in layflat hoses .....	329
Pressure drop in rubber hoses .....	328, 329
Properties of rubber .....	326
PVC chemical resistance chart .....	336-338
Rubber chemical resistance chart .....	330-335
Temperature chart for layflat hoses .....	336
Volumetric flowrate .....	329
Water discharge table .....	327
Hot water washdown gun (Flow Boss™) .....	86
Hydraulic couplings	
Agricultural interchange .....	230-232
Diagnostic ISO15171-1 .....	256, 257
European screw-together .....	254, 255
H-BOP series .....	192
High pressure screw-together .....	233, 234
HTE series .....	223-225
ISO7241 series 'A' .....	197, 198
ISO7241 series 'B' .....	187-190
ISO16028 flushface interchange	216-218, 222
ISO-B food grade coupling .....	195
ISO-B steam interchange .....	193
Snap-Tite '71' interchange .....	226, 227
Snap-Tite H/H interchange .....	243-253
Straight-through pressure-wash	238-242
TEMA european interchange .....	235-237
VEP-BOP series .....	214, 215
Wingstyle interchange .....	201-210

**I**

Interlocking clamps .....	146
---------------------------	-----

**K**

"King" fittings .....	88-90
King™	
Cables	
Straps .....	55
Hose menders .....	95
Whipsocks	
Shackles .....	53
Knife gate valve .....	282

**K****L**

Lanyard .....	43
Line strainers .....	295
Long shank couplings .....	71
Lubricators	
In-Line .....	56
Lugged water couplings .....	91, 92

**M**

Machined shank .....	88-90
Make-a-clamp kit .....	140
Manifolds	
Air receiver .....	55
Marine	
Strainers .....	297-302
Menders .....	68, 95
Metallic hoses .....	304
Mine water valve .....	277
Minsup double bolt clamps .....	145
Minsup safety claw clamps .....	145
MSHA regulations .....	377

**N**

Needle	
Bleed .....	292
Block and bleed .....	292
Mini .....	291
Multiport .....	291
Nitto compatible fittings, Dixon™ .....	179, 180
Nozzles	
Trigger spray guns .....	86
Washdown	
Flow Boss™ gun .....	86
Nut and tail .....	88

**O**

OSHA regulations .....	377
------------------------	-----

**P**

Pipe	
Couplings .....	260-263
Nipples .....	266
Pipe and pipe fittings technical .....	348-351
Flange specifications .....	352, 353
Thread information .....	348-351
Valve selection guide .....	371
Pneumatic	
Air King™ .....	44



- Pneumatic couplings  
 DF series industrial interchange 181-186  
 J series truflate interchange ..... 167-169  
 NK series nitto interchange ..... 179, 180  
 N series Dix-Lock™ ..... 170-175  
 P series Dual Lock™ ..... 176-178  
 Probes ..... 87  
 Push-on fittings ..... 66-68
- Q**
- Quick coupling air fittings. *See also* Air fittings  
 Quick release couplings ..... 259
- R**
- Reducing adaptors & couplers ..... 27, 28  
 Replacement handles  
 Cam & groove ..... 36  
 Roll grooved couplings ..... 266  
 Roll grooved fittings ..... 266  
 Rubber hoses ..... 305
- S**
- SAE fittings ..... 138-140  
 Safety  
 Cables  
 Shackles ..... 53  
 Check valves ..... 286  
 Clips and lanyards ..... 36  
 Vented ball valves ..... 268  
 Whipsocks  
 Shackles ..... 53  
 Safety cables ..... 53, 54  
 Safety clamps BS EN 14420-3:2004 ..... 149  
 Safety clips, Air King™ ..... 43  
 Safety information  
 BE SAFE ..... 308  
 General safety information ..... 310  
 Safety regulations ..... 377  
 Understanding the forces at work ..... 339  
 Sanitary fittings  
 Steam service DDC fittings ..... 161  
 Shackles ..... 53  
 Shank fittings ..... 88  
 Agri-Lock Bauer couplings ..... 98  
 Combination nipples ..... 88  
 Smooth tails ..... 47  
 Fixed and swivel flanged ..... 48  
 Strainers and skimmers ..... 96, 97  
 Short shanks ..... 95  
 Specialist and bespoke hoses ..... 306  
 Spiral PVC hoses ..... 305  
 Stainless steel  
 Boss™  
 Clamps ..... 146  
 Strainers ..... 294
- Steam  
 Valve, 250 lb ..... 268  
 Stems  
 Reusable brass ..... 70, 71  
 Storz fittings ..... 50-52  
 Strainers ..... 96, 97, 294  
 Marine ..... 297-299  
 Polypropylene ..... 294  
 Round hole ..... 294  
 Square hole ..... 294  
 T line ..... 295  
 Y line ..... 295  
 Straps  
 King Cable™ ..... 55  
 Swaging  
 External ..... 122, 123, 126, 129  
 Internal ..... 130-133  
 Swivels ..... 79-84  
 Hose barb ..... 62, 65, 66, 68, 70
- T**
- Tank truck  
 Swivels  
 Split flange components ..... 84  
 Nose piece ..... 84  
 Tank wagon  
 Couplings ..... 48  
 Spares and seals ..... 49  
 Technical information  
 Basic compounds in rubber hose ..... 327  
 Bolt tightening sequence ..... 358  
 Conversions  
 Feet of water to inches of mercury ..... 373  
 Imperial to decimal conversion chart ..... 374  
 Measurement information ..... 373  
 Pressure conversions ..... 373  
 Temperature conversions ..... 375  
 Vacuum conversion table ..... 373  
 Couplings. *See* Hose fittings and couplings tech  
 Crimp recommendation guide ..... 365  
 Force chart ..... 340  
 Formulae ..... 376  
 Glossary of terms ..... 379, 380  
 Hose. *See* Hose technical  
 Hose assemblies. *See* Hose assemblies technical  
 Hose fittings. *See* Hose fittings and couplings tech  
 Pipe and pipe fittings. *See also* Pipe and pipe fittings technical  
 Flange specifications ..... 352, 353  
 Steam tables ..... 372  
 Thread information ..... 348-351  
 Valve selection guide ..... 371  
 Tees  
 Splicers ..... 64  
 T line strainers ..... 295

**U**

Universal couplings	
Air King™	44

**V**

Valves	
250 lb. steam	268
Back flow prevention	
Single check valves	290
Single detector	290
Ball	268
Butterfly	284
Butterfly valves	283, 285
Monitored	285
Shouldered	283
Wafer	282-285
Check	286, 287
Check valves	287-290
Cast iron	287
Flanged ball	287
Stainless steel	287
Swing	287, 288
Gate valves	277-282
Flanged	279-281
Grooved	278
Hand wheels	282
Knife	282
Shouldered	279
Sluice	282
Globe valves	289
Horizontal swing check	286
Miscellaneous valves and strainers	
Relief	293
Needle	
Hydraulic	
Bleed	292
Block and bleed	292
Mini	291
Multiport	291
Safety check	286
Safety vented	268
Swing check	286
Wafer	284
Valves technical	
Valve selection guide	371
Vent-Lock™	16

**Y**

Y line strainers	295
------------------	-----

**W**

Washers	
Ground joint	105
Washer seal	105
Washer type couplings	105
Welding hose. <i>See also</i> Hose	
Whipsocks	
Shackles	53
Worm gear clamps	138-140

# Dixon Terms & Conditions

---

## Limited Warranty

Dixon Group Europe Ltd (herein called "Dixon") warrants the products described herein, and manufactured by Dixon to be free from defects in material and workmanship for a period of one (1) year from date of shipment by Dixon under normal use and service. It's sole obligation under this warranty being limited to repairing or replacing, as hereinafter provided, at its option any product found to Dixon's satisfaction to be defective upon examination by it, provided that such product shall be returned for inspection to Dixon's factory within three (3) months after discovery of the defect. The repair or replacement of defective products will be made without charge for parts or labour. This warranty shall not apply to: (a) parts or products not manufactured by Dixon, the warranty of such items being limited to the actual warranty extended to Dixon by its supplier; (b) any product that has been subject to abuse, negligence, accident, or misapplication; (c) any product altered or repaired by others than Dixon; and (d) to normal maintenance services and the replacement of service items (such as washers, gaskets and lubricants) made in connection with such services. To the extent permitted by United Kingdom law, this limited warranty shall extend only to the buyer and any other person reasonably expected to use or consume the goods who is injured in person by any breach of the warranty. No action may be brought against Dixon for an alleged breach of warranty unless such action is instituted within one (1) year from the date the cause of action accrues. This limited warranty shall be construed and enforced to the fullest extent allowable by applicable United Kingdom law.

**OTHER THAN THE OBLIGATION OF DIXON SET FORTH HEREIN, DIXON DISCLAIMS ALL WARRANTIES, EXPRESS OR IMPLIED, INCLUDING BUT NOT LIMITED TO ANY IMPLIED WARRANTIES OF MERCHANTABILITY OR FITNESS FOR A PARTICULAR PURPOSE, AND ANY OTHER OBLIGATION OR LIABILITY. THE FOREGOING CONSTITUTES DIXON'S SOLE OBLIGATION WITH RESPECT TO DAMAGES, WHETHER DIRECT, INCIDENTAL OR CONSEQUENTIAL, RESULTING FROM THE USE OR PERFORMANCE OF THE PRODUCT.**

Some products and sizes may be discontinued when stock is depleted, or may require a minimum quantity for ordering.

Dixon Group Europe Ltd is committed to a policy of continuous development, and as such, the above detailed specification and may be subject to change without notice. Dixon Group Europe Ltd reserves the right to change and modify designs and specification without notice.

---

## Pricing

Dixon will always try to maintain pricing, however, with the fluctuation of material cost we may be forced to change prices. Please be aware pricing is subject to change without notice.

---

## Freight/Postage & Carriage Charges

Postage & carriage charges are at the customer's expense and will be charged at current appropriate rates.

---

## Returns

Dixon will always try to maintain pricing, however, with the fluctuation of material cost we may be forced to change prices. Please be aware pricing is subject to change without notice. The customer must call to receive a CCR number prior to returning goods to Dixon and shipping will be at the customer's expense, unless it is determined Dixon created the reason for the return.

A re-stocking charge of 25% applies to all returns.

---

## Limits of Liability

This catalogue is intended as a product offering. It is not intended to be a user or technical manual. Information in this catalogue is subject to change without notice. All users and distributors of products sold through this catalogue should contact Dixon with questions of use, compatibility's, coupling procedures and life of product. Dixon's full time engineering and test staff is always available to recommend uses and to assist distributors and users with questions.

---

## Copyright

Copyright© 2019 by Dixon Group Europe Ltd.

All rights reserved. This book is copyrighted material. Use, reproduction or copying of it by anyone other than Dixon is strictly forbidden without its express written consent.

# DGEL2020 INDEX

**A** Cam & Groove  
pages 7 - 39

**B** Industrial Hose Fittings  
pages 40 - 135

**C** Clamps  
pages 136 - 150

**D** Dry Disconnect Fittings  
pages 151 - 165

**E** Hydraulic & Pneumatic  
Quick Disconnects  
pages 166 - 257

**F** Pipe, Pipe Fittings &  
Welding  
pages 258 - 266

**G** Valves  
pages 267 - 295

**H** Marine  
pages 296 - 302

**I** Hose  
pages 303 - 306

**J** Safety & Technical  
pages 307 - 380

**K** Index  
pages 381 - 392

## Dixon Worldwide

### Dixon Deutschland GmbH

Godesberger Strasse 20b  
D-53842 Troisdorf-Spich  
Germany  
ph: +49 (0)2241 844 06-0  
email: info@dixon-deutschland.de

### Dixon France

Parc Des Mardelles  
44, rue Maurice de Broglie - Bât A15  
93600 Aulnay-Sous-Bois  
France  
ph: +33 171 84 10 16  
email: sales@dixonfrance.fr

### Dixon Middle East

C3-035, PO Box 121599,  
Saif Zone-Sharjah,  
United Arab Emirates  
ph: +97165741488  
email: sales@dixonme.com

### Dixon Russia

17A Aleksandrovskoy Fermi Prospekt  
192174  
Saint Petersburg  
Russia  
ph: +7 (812) 677 54 47  
email: info@dixonrussia.ru

### Dixon™

800 High Street  
Chestertown  
MD 21620  
USA  
ph: +1 410 778 2000  
email: sales@dixonvalve.com

### Dixon™ (Shanghai) Trading Co. Ltd

Room 1201 Sun Building  
No 3553 North Zhongshan Road  
Putuo District  
Shanghai 200063  
ph: +86 021 6173 7998  
fax: +86 021 6173 8589  
email: customerservice@dixonvalve.com.cn  
web: dixonvalve.com.cn

### Dixon™ (Asia Pacific) Pty Ltd

170 Francis Road • Wingfield SA 5013  
PO Box 2491 • Regency Park SA 5942  
ph: +61 8 8202 6000  
email: customerservice@dixonvalve.com.au  
web: dixonvalve.com.au



*The Right Connection®*

## Dixon™ Group Europe Limited

350 Leach Place

Walton Summit Centre, Preston PR5 8AS, UK

ph: +44 (0)1772 323529

fax: +44 (0)1772 314664

email: [sales@dixoneurope.co.uk](mailto:sales@dixoneurope.co.uk)

[europe.dixonvalve.com](http://europe.dixonvalve.com)

connect with us on

