

Ball screws

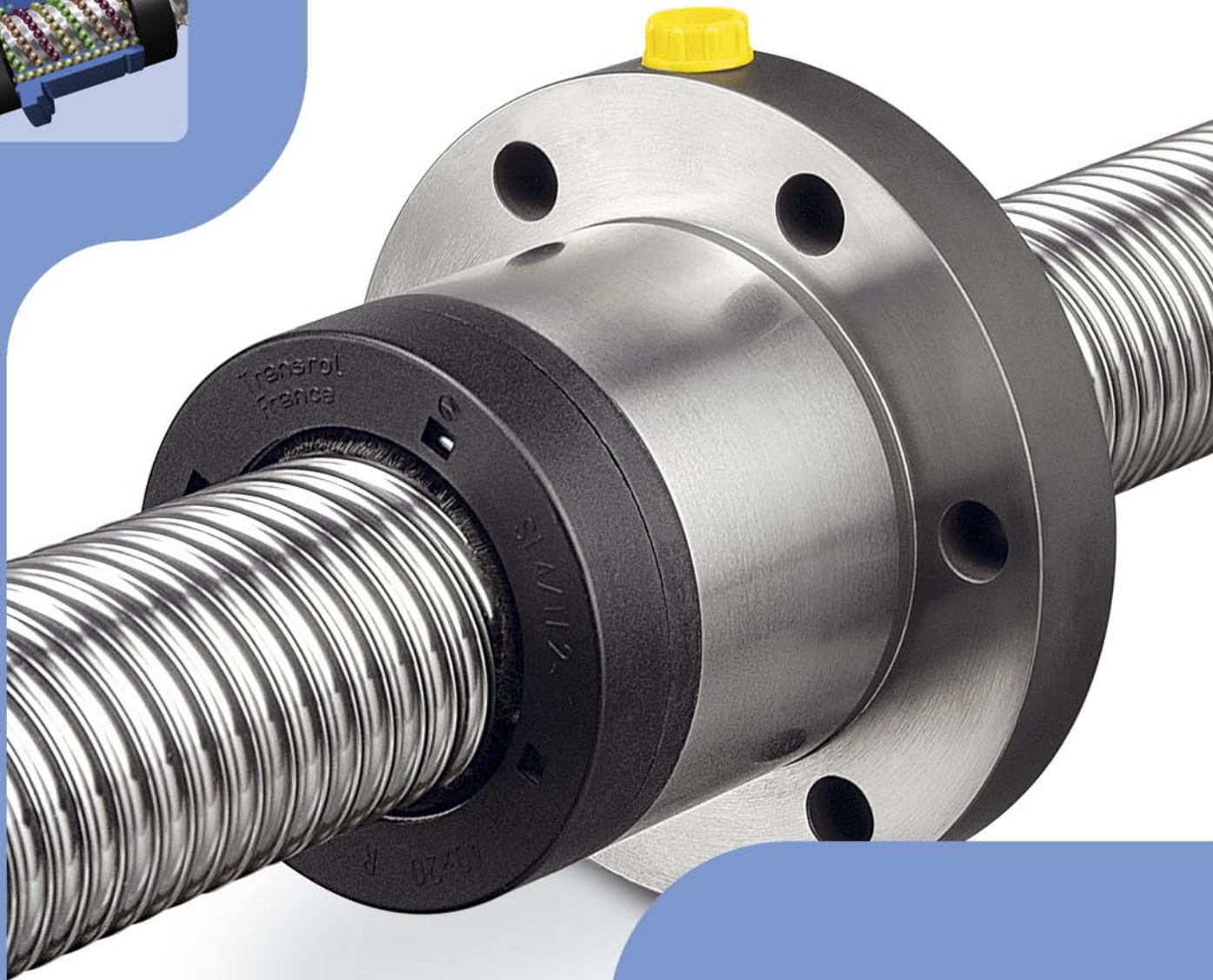

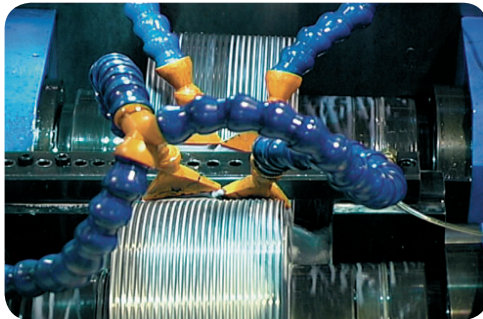

Medical equipment

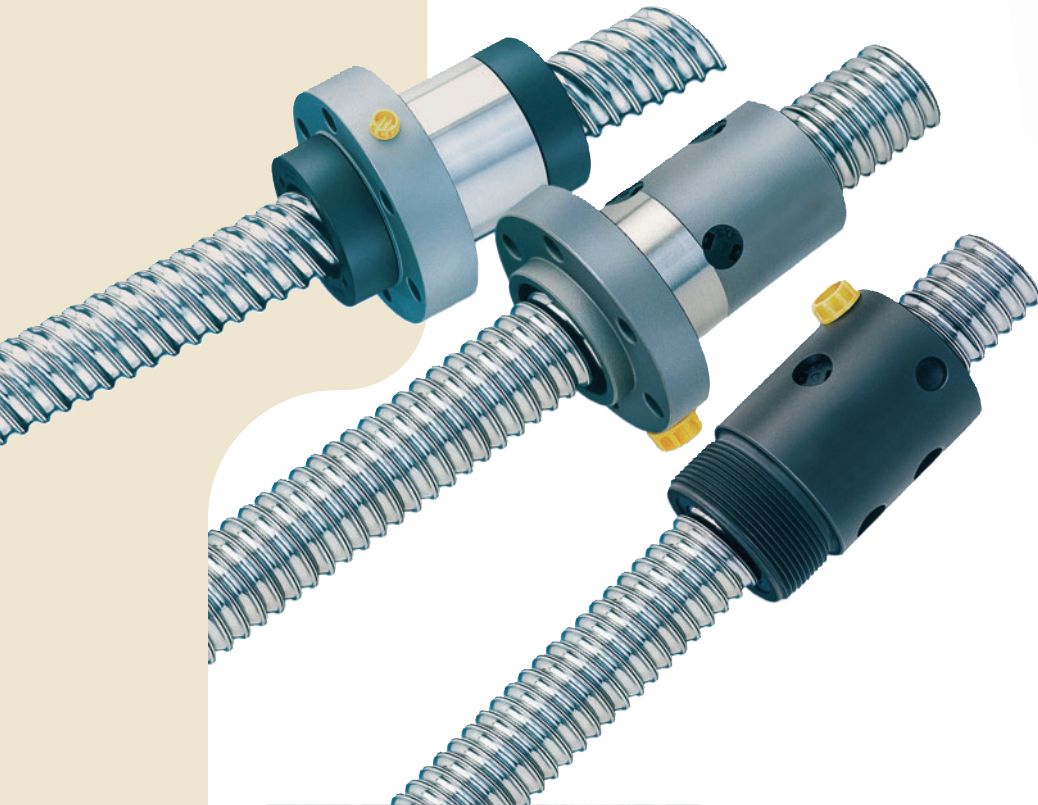
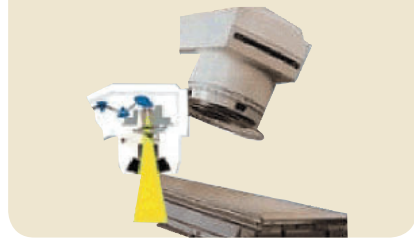

Press brakes

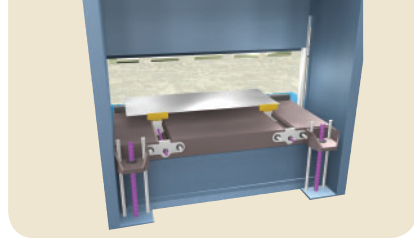

EDM

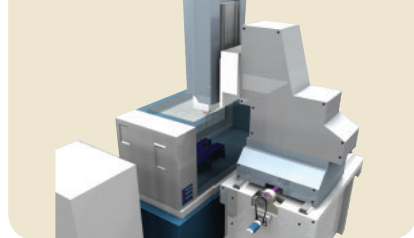

Woodworking

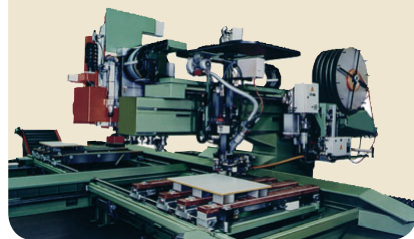

Contents

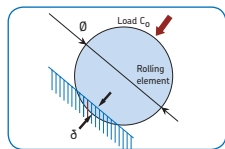

Recommendations for selection

Overview: ball screw nuts	05
Basic dynamic load rating (C_a)	05
Static load carrying capacity (C_{0a})	06
Critical rotating speed for screw shafts	06
Permissible speed limit	07
Lubrication	07
Efficiency and back-driving	07
Axial play and preload	08
Static axial stiffness of a complete assembly	08
Screw shaft buckling	08
Manufacturing precision	09
Materials and heat treatments	09

1



Recommendations for assembly

Radial and moment loads	10
Alignment	10
Lubrication	10
Designing the screw shaft ends	10
Operating temperature	10
Separating the nut from the screw shaft	11
Starting-up the screw	11

2



Other technical data

Lead precision according to ISO	12
---------------------------------------	----

3



Product information

SD/BD miniature screws	14
SDS/BDS/SHS miniature screws in stainless steel	16
SH miniature screws	18
SX/BX universal screws	20
Accessories for SX/BX nuts	22
SND/BND precision screws, DIN standard	24
PND preloaded screws, DIN standard	26
SN/BN precision screws	28
PN preloaded screws	30
SL/BL long lead screws	32
SLT/BLT rotating nuts	34
Standard machined ends	36
Screw shaft accessories	40
Calculation formulas	46
Designation	49
Roller screws and cylinders	50

4

Nuts for ball screws

Screw assembly

Type of recirculation

SD/BD

Internal, by inserts



SDS/BDS

Stainless steel optional

SH

External, by integrated tube



SHS

Stainless steel optional

SX/BX

Internal, by inserts



SND/BND/PND

Internal, by inserts

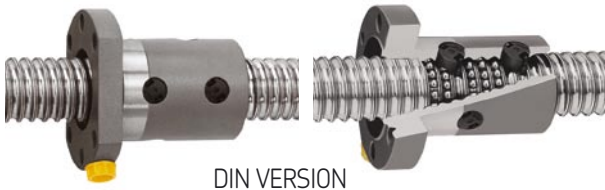

SN/BN/PN

Internal, by inserts

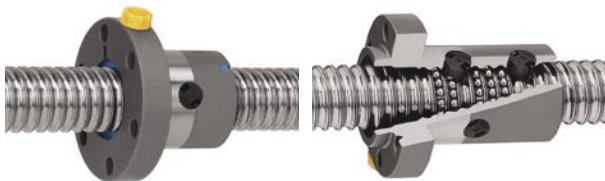

SL/BL - SLD/BLD

By faces

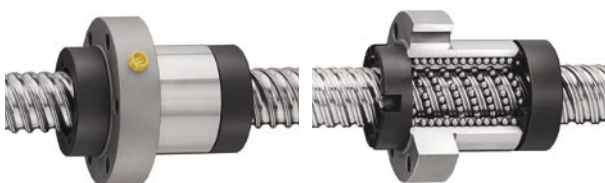

Diameter		Right hand lead		Axial play		Backlash elimination		Preload for optimum rigidity		Nut accessories		Screw accessories		Catalogue page
8	2,5	SD	BD											14
10	2 - 4	SD	BD											
12	2 - 4 - 5	SD	BD											
14	4	SD	BD											
16	2 - 5 - 10	SD	BD								yes			16
6	2	SH												18
10	3	SH												
12,7	12,7	SH												16
20	5	SX	BX							yes	yes			20
25	5 - 10	SX	BX							yes	yes			
32	5 - 10	SX	BX							yes	yes			
40	5 - 10	SX	BX							yes	yes			
50	10	SX	BX							yes	yes			
63	10	SX	BX							yes	yes			
16	5 - 10	SND	BND	PND							yes			24
20	5	SND	BND	PND							yes			
25	5 - 10	SND	BND	PND							yes			
32	5 - 10	SND	BND	PND							yes			
40	5 - 10	SND	BND	PND							yes			
50	10	SND	BND	PND							yes			
63	10	SND	BND	PND							yes			
16	5	SN	BN	PN							yes			28
20	5	SN	BN	PN							yes			
25	5 - 10	SN	BN	PN							yes			
32	5 - 10	SN	BN	PN							yes			
40	5 - 10	SN	BN	PN							yes			
50	10	SN	BN	PN							yes			
63	10	SN	BN	PN							yes			
25	20 - 25	SL	BL								yes			32
32	20 - 40	SL	BL								yes			
32	32	SL	BL								yes			
32	32	SLD	BLD								yes			
40	20 - 40	SL	BL								yes			
50	50	SL	BL								yes			

SLT, BLT, Rotating nuts

with SL/BL long lead screw

34

Accessories: FLBU, PLBU, BUF

40

Recommendations for selection

Only basic selection parameters are included. To make the very best selection of a ball screw, the designer should specify such critical parameters as the load profile, the linear or rotational speed, the rates of acceleration and deceleration, the cycle rate, the environment, the required life, the lead accuracy, the stiffness, and any other special requirement. If in doubt, please consult an SKF ball screw specialist before placing an order.

Basic dynamic load rating (C_a)

The dynamic rating is used to compute the fatigue life of ball screws. It is the axial load constant in magnitude and direction, and acting centrally under which the nominal life (as defined by ISO) reaches one million revolutions.

Nominal fatigue life L_{10}

The nominal life of a ball screw is the number of revolutions (or the number of operating hours at a given constant speed) which the ball screw is capable of enduring before the first sign of fatigue (flaking, spalling) occurs on one of the rolling surfaces.

It is however evident from both laboratory tests and practical experience that seemingly identical ball screws operating under identical conditions have different lives, hence the notion of *nominal life*.

It is, in accordance with ISO definition, the life achieved or exceeded by 90 % of a sufficiently large group of apparently identical ball screws, working in identical conditions (alignment, axial and centrally applied load, speed, acceleration, lubrication, temperature and cleanliness).

Service life

The actual life achieved by a specific ball screw before it fails is known as “service life”. Failure is not only by fatigue (flaking or spalling); but also by inadequate lubrication and wear; wear of the recirculation system, corrosion, contamination, and, more generally, by loss of the functional characteristics required by the application. Experience acquired with similar applications will help to select the proper screw to obtain the required service life. One must also take into account structural requirements such as the strength of screw ends and nut attachments, due to the loads applied on these elements in service. To attain L_{10} life performance a mean working load of up to 80 % of C_a and a stroke higher than 4 leads are permitted.

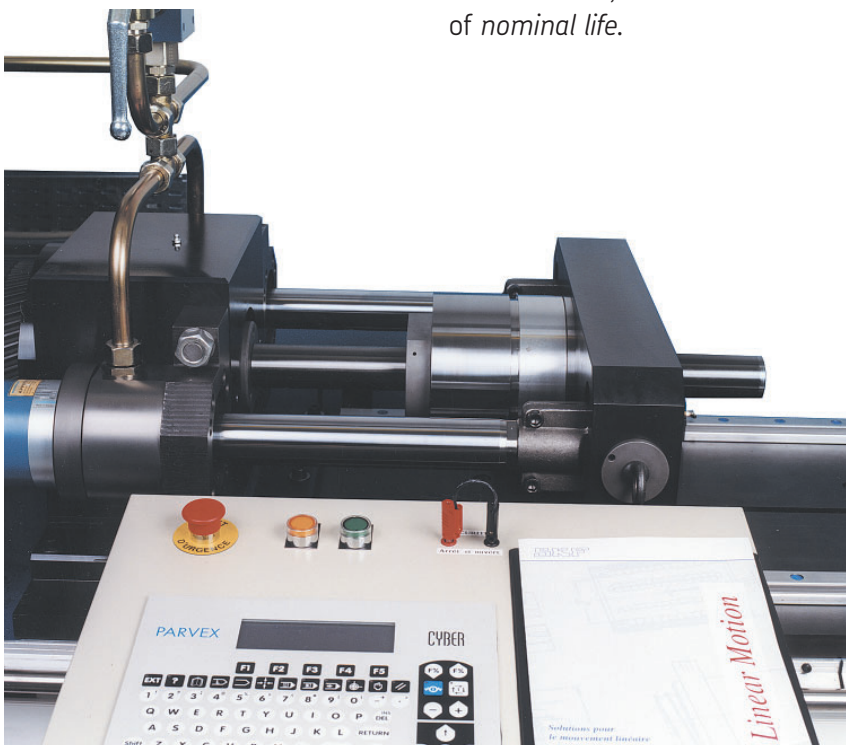

Life test bench

(1) SKF can help you to define this value in relation with the actual conditions of service.

Equivalent dynamic loads

The loads acting on the screw can be calculated according to the laws of mechanics if the external forces (e.g. power transmission, work, rotary and linear inertia forces) are known or can be calculated. It is necessary to calculate the equivalent dynamic load.

Radial and moment loads must be taken by linear bearing systems. It is extremely important to resolve these problems at the earliest conceptual stage. These forces are detrimental to the life and the expected performance of the screw.

Fluctuating load

When the load fluctuates during the working cycle, it is necessary to calculate the equivalent dynamic load: this load is defined as that hypothetical load, constant in magnitude and direction, acting axially and centrally on the screw which, if applied, would have the same influence on the screw life as the actual loads to which the screw is subjected.

Additional loads due, for example to misalignment, uneven loading, shocks, and so on, must be taken in account.

Their influence on the nominal life of the screw is generally taken care of, consult SKF for advice.

Static load carrying capacity (C_{0a})

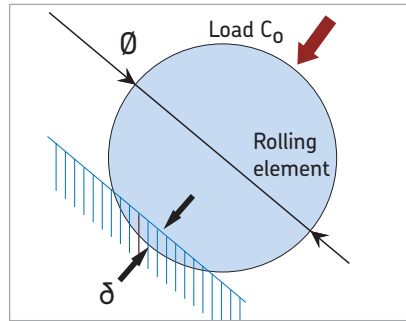

Ball screws should be selected on the basis of the basic static load rating C_{0a} instead of on bearing life when they are submitted to continuous or intermittent shock loads, while stationary or rotating at very low speed for short duration. The permissible load is determined by the permanent deformation caused by the load acting at the contact points.

It is defined by ISO standards as the purely axially and centrally applied static load which will create, by calculation, a total (rolling element + thread surface) permanent deformation equal to 0.0001 of the diameter of the rolling element.

A ball screw must be selected by its basic static load rating which must be, at least, equal to the product of the maximum axial static load applied and a safety factor " s_0 ".

The safety factor is selected in relation with past experience of similar applications and requirements of running smoothness and noise level (1).

Critical rotating speed for screw shafts

The shaft is equated to a cylinder, the diameter of which is the root diameter of the thread. The formulas use a parameter the value of which is dictated by the mounting of the screw shaft (whether it is simply supported or fixed).

As a rule the nut is not considered as a support of the screw shaft. Because of the potential inaccuracies in the mounting of the screw assembly, a safety factor of 0.80 is applied to the calculated critical speeds.

Calculations which consider the nut as a support of the shaft, or reduce the safety factor, require practical tests and possibly an optimization of the design (1).

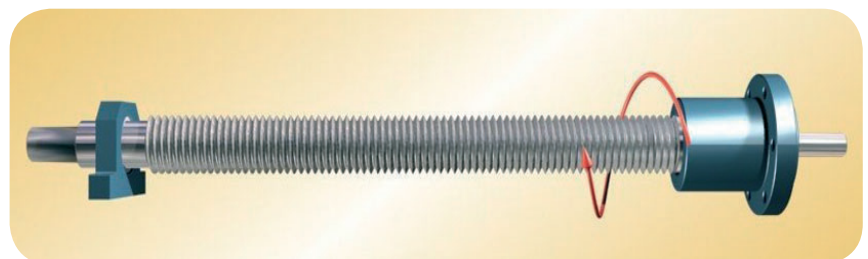

(1) SKF can help you to define this value in relation with the actual conditions of service.

Permissible speed limit

The permissible speed limit is that speed which a screw cannot reliably exceed at any time. It is generally the limiting speed of the recirculation system in the nut. It is expressed as the product of the rpm and the nominal diameter of the screw shaft (in mm).

The speed limits quoted in this catalogue are the maximum speeds that may be applied through very short periods and in optimized running conditions of alignment, light external load and preload with monitored lubrication.

Running a screw continuously at the permissible speed limit may lead to a reduction of the calculated life of the nut mechanism.



High speed associated with high load requires a large input torque and yields a relatively short nominal life (1).

In the case of high acceleration and deceleration, it is recommended to either work under a nominal external load or to apply a light preload to the nut to avoid internal sliding during reversal.

The value of preload of screws submitted to high velocity must be that preload which ensures that the rolling elements do not slide (1).

Too high a preload will create unacceptable increases of the internal temperature.

Lubrication

The lubrication of screws rotating at high speed must be properly considered in quantity and quality.

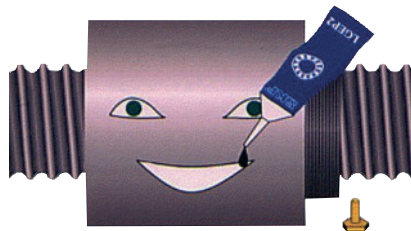

The volume, spread and frequency of the application of the lubricant (oil or grease) must be properly selected and monitored. At high speed the lubricant spread on the surface of the screw shaft may be thrown off by centrifugal forces. It is important to monitor this phenomenon during the first run at high speed and possibly adapt the frequency of relubrication or the flow of lubricant, or select a lubricant with a different viscosity.

Monitoring the steady temperature reached by the nut permits the frequency of relubrication or the oil flow rate to be optimized.

Efficiency and back-driving

The performance of a screw is mainly dependant on the geometry of the contact surfaces and their finish as well as the helix angle of the thread. It is, also, dependant on the working conditions of the screw (load, speed, lubrication, preload, alignment, etc...).

The "direct efficiency" is used to define the input torque required to transform the rotation of one member into the translation of the other. Conversely, the "indirect efficiency" is used to define the axial load required to transform the translation of one member into the rotation of the other one. It is used, also, to define the braking torque required to prevent that rotation.

It is safe to consider that these screws are reversible or back-driveable under almost all circumstances.

It is therefore necessary to design a brake mechanism if backdriving is to be avoided (gear reducers or brake).

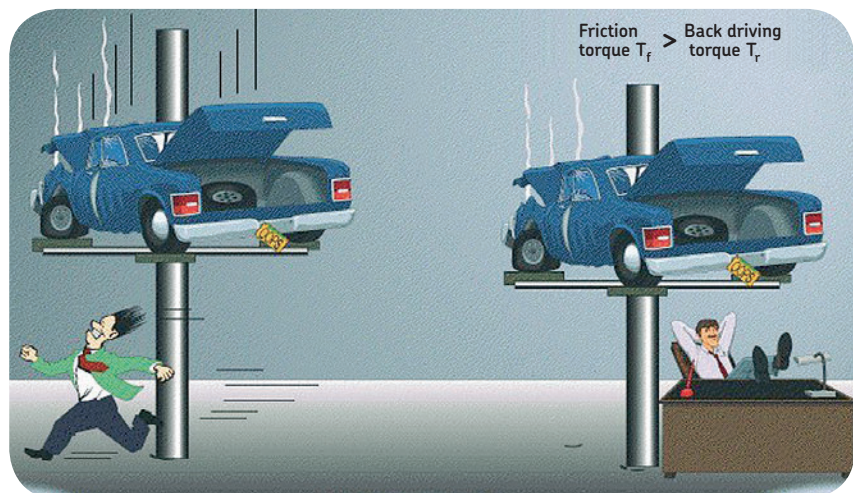

(1) SKF can help you to define this value in relation with the actual conditions of service.

Preload torque:

Internally preloaded screws exhibit a torque due to this preload. This persists even when they are not externally loaded. Preload torque is measured when assembly is lubricated with ISO grade 64 oil.

Starting torque:

This is defined as the torque needed to overcome the following to start rotation:

- a) the total inertia of all moving parts accelerated by the energy source (including rotation and linear movement).
- b) the internal friction of the screw/nut assembly, bearing and associated guiding devices.

In general, torque to overcome inertia (a) is greater than friction torque (b).

The coefficient of friction of the high efficiency screw when starting μ_s is estimated at up to double the dynamic coefficient μ , under normal conditions of use.

Axial play and preload

Preloaded nuts are subject to much less elastic deformation than non-preloaded nuts. Therefore they should be used whenever the accuracy of positioning under load is important.

Preload is that force applied to a set of two half nuts to either press them together or push them apart with the purpose of eliminating backlash or increasing the rigidity or stiffness of the assembly. The preload is defined by the value of the preload torque (see under that heading in the previous paragraph). The torque depends on the type of nut and on the mode of preload (elastic or rigid).

Static axial stiffness of a complete assembly

It is the ratio of the external axial load applied to the system and the axial displacement of the face of the nut in relation with the fixed (anchored) end of the screw shaft. The inverse of the *rigidity of the total system* is equal to the sum of all the inverses of the rigidity of each of the components (screw shaft, nut as mounted on the shaft, supporting bearing, supporting housings, etc...).

Because of this, the rigidity of the total system is always less than the smallest individual rigidity.

Nut rigidity

When a preload is applied to a nut, firstly, the internal play is eliminated, then, the Hertzian elastic deformation increases as the preload is applied so that the overall rigidity increases.

The theoretical deformation does not take into account machining inaccuracies, actual sharing of the load between the different contact surfaces, the elasticity of the nut and of the screw shaft. The practical stiffness values given in the catalogue are lower than the theoretical values for this reason. The rigidity values given in the SKF ball screw catalogue are individual practical values for the assembled nut.

They are determined by SKF based on the value of the selected basic preload and an external load equal to twice this preload.

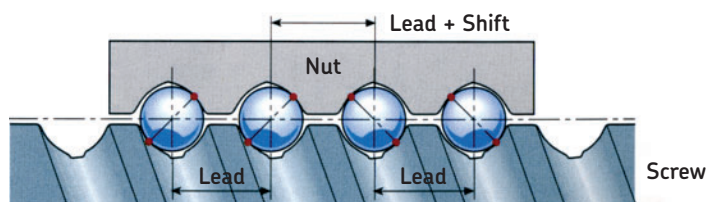

Elastic deformation of screw shaft

This deformation is proportional to its length and inversely proportional to the square of the root diameter.

According to the relative importance of the screw deformation (see rigidity of the total system), too large an increase in the preload of the nut and supporting bearings yields a limited increase of rigidity and notably increases the preload torque and therefore the running temperature.

Consequently, the preload stated in the catalogue for each dimension is optimum and should not be increased.

Screw shaft buckling

The column loading of the screw shaft must be checked when it is submitted to compression loading (whether dynamically or statically).

The maximum permissible compressive load is calculated using the Euler formulas. It is then multiplied by a safety factor of 3 to 5, depending on the application.

The type of end mounting of the shaft is critical to select the proper coefficients to be used in the Euler formulas.

When the screw shaft comprises a single diameter, the root diameter is used for the calculation. When the screw comprises different sections with various diameters, calculations becomes more complex (1).

(1) SKF can help you to define this value in relation with the actual conditions of service.

Manufacturing precision

Generally speaking, the precision indication given in the designation defines the lead precisions see page 12 - lead precision according to ISO - (ex. G5 - G7...).

Parameters other than lead precision correspond to our internal standards (generally based on ISO "class 7").

If you require special tolerances (for example class 5) please specify when requesting a quotation or ordering.

Materials and heat treatments

Standard screw shafts are machined from steel which is surface hardened by induction (42CrMo4-NF EN10083-1 for diameters > 16 mm and C45E for diameters ≤ 16 mm).

Standard nuts are machined in steel which is through hardened (100 Cr6 - NFA 35.565 or equivalent for diameters ≥ 20 mm and carbon steel for diameters < 20 mm). Hardness of the contact surfaces is 56-60 HRc, depending on diameter, for standard screws.

Most assemblies made of stainless material have a surface hardness in the range 50 to 58 HRc, depending on the type. The load rating of the catalogue are given only for standard screws.

Number of circuits of balls

A nut is defined by the number of ball turns which support the load.

The number is changing, according to the product and the combination diameter/lead.

It is defined by the number of circuits and their type.

Recirculation inserts

The standard products have been fitted with composite ball recirculation inserts.

System performance is improved because of the smoother ball recirculation. This results from the improved precision of the moulded insert when compared to the former steel insert. If the product is used in severe applications, or the insert is used to prevent collapse (especially in vertical applications), a steel version is available. In such cases, the specifier should consult SKF Linear Motion to obtain the optimum solution.

Working environment

Our products have not been developed for use in an explosive atmosphere, consequently we cannot take any responsibility for the use in this field.

NOTE: 42 CrMo4, an AFNOR reference is similar to AISI 4140; 100Cr6 is similar to AISI 52100.

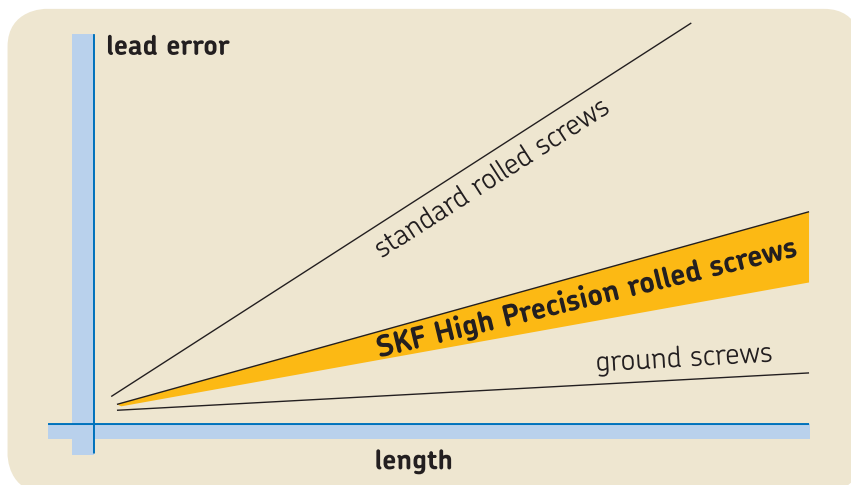
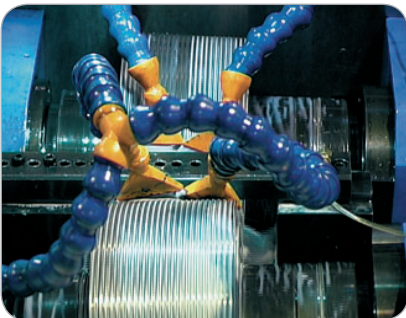

(1) SKF can help you to define this value in relation with the actual conditions of service.

Recommended assembly procedure

Ball screws are precision components and should be handled with care to avoid shocks. When stored out of the shipping crate they must lie on wooden or plastic vee blocks and should not be allowed to sag. Screw assemblies are shipped, wrapped in a heavy gauge plastic tube which protects them from foreign material and possible pollution. They should stay wrapped until they are used.

Radial and moment loads

Any radial or moment load on the nut will overload some of the contact surfaces, thus significantly reducing life (fig. 1).

Alignment

SKF linear guidance components should be used to ensure correct alignment and avoid non-axial loading. The parallelism of the screw shaft with the guiding devices must be checked. If external linear guidance proves impractical, we suggest mounting the nut on trunnions or gimbals and the screw shaft in self-aligning bearings.

Mounting the screw in tension helps align it properly and eliminates buckling.

Lubrication

Good lubrication is essential for the proper functioning of the screw and for its long term reliability (1).

Before shipping, the screw is coated with a protective fluid that dries to a film. *This protective film is not a lubricant.*

Depending on the selected lubricant, it may be necessary to remove this film before applying the lubricant (there may be a risk of non-compatibility).

If this operation is performed in a potentially polluted atmosphere it is highly recommended to proceed with a thorough cleaning of the assembly.

Designing the screw shaft ends

Generally speaking, when the ends of the screw shaft are specified by the customer's engineering personnel, it is their responsibility to check the strength of these ends. However, we offer in pages 36 to 39 of this catalogue, a choice of standard machined ends. As far as possible, we recommend their use.

Whatever your choice may be, please keep in mind that no dimension on the shaft ends can exceed d_0 (otherwise traces of the root of thread will appear or the shaft must be made by joining 2 pieces).

A minimum shoulder should be sufficient to maintain the internal bearing.

Operating temperature

Screws made from standard steel (see page 9) and operating under normal loads can sustain temperatures in the range $-20\text{ }^{\circ}\text{C}$ to $+110\text{ }^{\circ}\text{C}$.

Between $+110\text{ }^{\circ}\text{C}$ and $+130\text{ }^{\circ}\text{C}$, SKF must be notified so that it adapts the annealing procedure and checks that the application can be successful with a hardness below the standard minimum value (see page 9).

Above $+130\text{ }^{\circ}\text{C}$, steels adapted to the temperature of the application should be selected (100Cr6, special steel, etc...).

Consult SKF for advice.

Operating at high temperature will lower the hardness of the steel, alter the accuracy of the thread and may increase the oxidability of the materials or change lubricant properties.

fig. 1

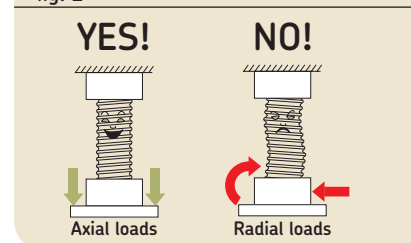
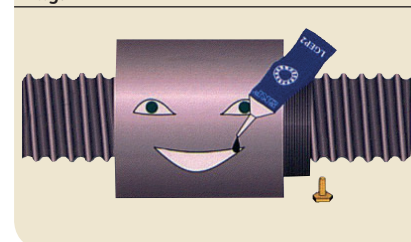

fig. 2



(1) SKF can help you to define this value in relation with the actual conditions of service.

Separating the nut from the screw shaft

Never screw the nut off the shaft without a mandrel to prevent the balls coming out (fig. 1).

1. Remove the retaining strap
2. Hold the sleeve against the ball track (a). If the sleeve does not go over the diameter next to the ball track, adhesive tape can be used (b) or the sleeve held against the unmachined end (c). (fig. 2)
3. Without forcing, engage the nut in the screw thread.

Starting-up the screw

After the assembly has been cleaned, mounted and lubricated, it is recommended that the nut is allowed to make several full strokes at low speed; to check the proper positioning of the limit switches or reversing mechanism before applying the full load and the full speed.

NOTE:

Instructions for most operations like mounting a nut on a screw shaft, a wiper on a nut, etc... are available in separate sheets delivered with the product: please refer to them.

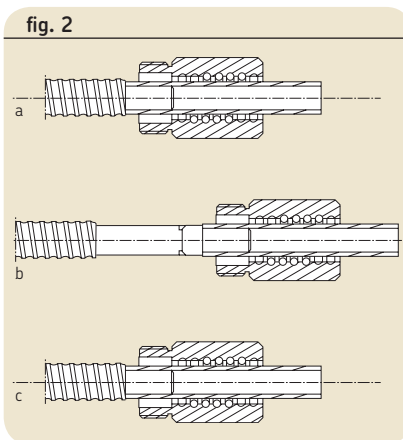
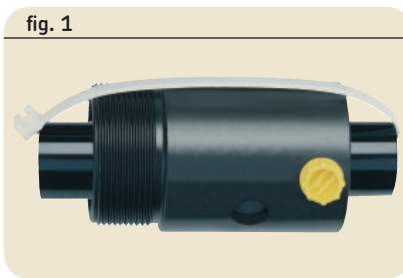

Mounting instructions Ball screws

1 *Unpacking & storing*

- The nut should never be separated from the screw shaft without using a sleeve. If you receive a nut on sleeve, **don't cut the plastic fixation** before final assembly.
- The location must be chosen so that the components will not be exposed to dirt, shocks, humidity and other detrimental actions.
- The screw assemblies should be stacked horizontally, placed on 2 V-blocks made of hard plastic or light metal alloy on the screw thread or, when the assembly is short, the bearing seats should rest in the Vs. Do not allow the screw assembly to be supported on a shelf solely by the nut body.
- Before shipping, the screw is coated with a protective fluid that dries to a film. This protective film, called Quakers, is not a lubricant. Depending on the selected lubricant, it is necessary to remove this film before applying the lubricant (there may be a risk of non-compatibility). If this operation is performed in a potentially polluting atmosphere, it is highly recommended to proceed with a thorough cleaning of the assembly.

2 *Preparing screw for mounting*

2.1 - Nut mounted on the shaft.
As far as possible, don't remove the nut, especially for preloaded nuts. If you need to remove it, i.e. for end machining, check the nut orientation before dismounting and use a sleeve.

2.2 - Nut on a sleeve, screw shaft ends already machined.

- Clean the nut and the screw shaft with a good solvent (see fig n° 1).
- Install the wipers on the nut (see fig n° 2A - 2B - 2C - 2D).
- Install the nut on the screw shaft (take care of the nut orientation) (see fig n° 3A); in case of a long lead SL, see fig n° 3B.

2.3 - Nut on sleeve - screw shafts with ends not yet machined.

- Machine the shaft ends: standard screw shafts are made of steel which is surface hardened (56 to 60 Hrc). It may be useful to anneal the shaft to do this operation.
- Continue as indicated in 2.2.

3 *Lubrication*

Good lubrication is essential for the proper functioning of the screw and for its long term reliability. Don't hesitate to ask for advice to be sure to use our products in the best possible conditions.

4 *Mounting the screw assembly on the machine*

- Check that the end bearings and the guidance devices are aligned with the shaft.
- Check stroke and limit switches: the screw assembly should be driven back and forth a couple of times under low speed (< 50 rpm) and light load (not to exceed 5% of the dynamic rating).

2 V-blocks

Plastic fixation

Lubrication

Guidance devices

YES!

Add both

NO!

Reduce both

Lead precision according to ISO

Lead precision is measured at 20 °C on the useful stroke l_u , which is the threaded length decreased, at each end, by the length l_e equal to the screw shaft diameter.

V_{300p} μm	G5 23			G7 35			G9 87		
	l_u mm	e_p μm	v_{up}	e_p	v_{up}	e_p	v_{up}		
0 - 315	23	23	52	35	130	87			
(315) - 400	25	25	57	40	140	100			
(400) - 500	27	26	63	46	155	115			
(500) - 630	32	29	70	52	175	130			
(630) - 800	36	31	80	57	200	140			
(800) - 1000	40	34	90	63	230	155			
(1000) - 1250	47	39	105	70	260	175			
(1250) - 1600	55	44	125	80	310	200			
(1600) - 2000	65	51	150	90	370	230			
(2000) - 2500	78	59	175	105	440	260			
(2500) - 3150	96	69	210	125	530	310			
(3150) - 4000	115	82	260	150	640	370			
(4000) - 5000	140	99	320	175	790	440			
(5000) - 6000	170	119	390	210	960	530			

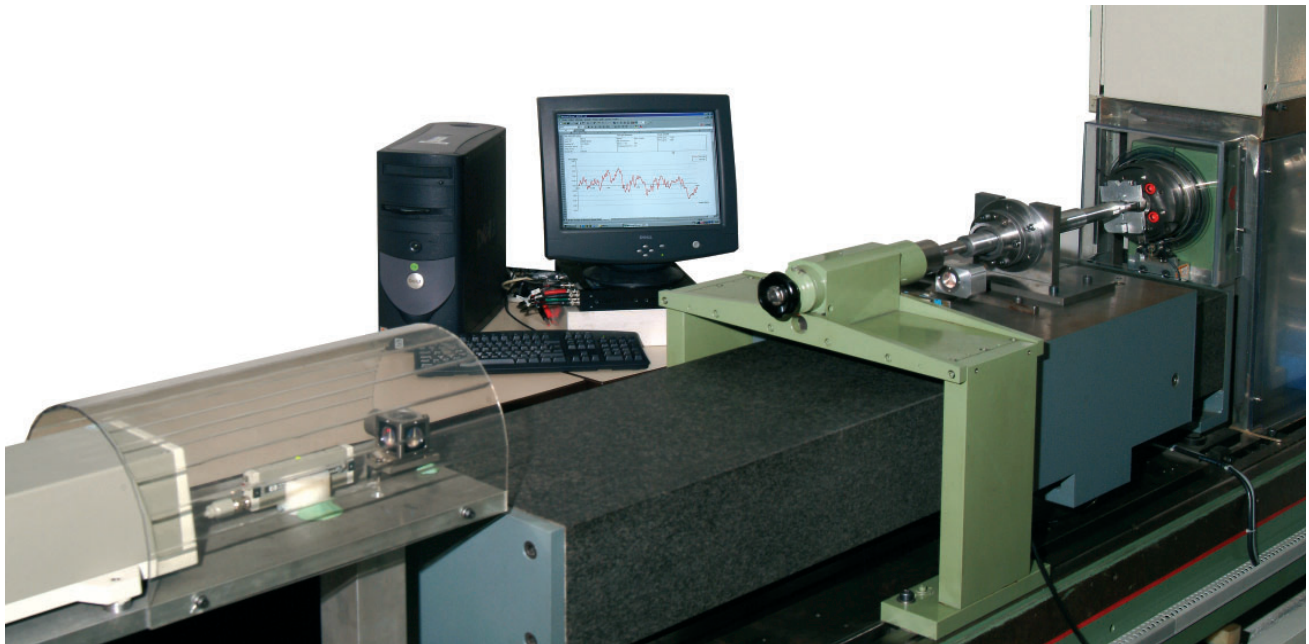

Lead accuracy control on a complete assembly

- l_u = useful travel
- l_e = excess travel (no lead precision required)
- l_o = nominal travel
- l_s = specified travel
- c = travel compensation (difference between l_s and l_o to be defined by the customer, for instance to compensate an expansion)
- e_p = tolerance over the specified travel
- V = travel variation (or permissible band width)
- V_{300p} = maximum permitted travel variation over 300 mm
- V_{up} = maximum permitted travel variation over the useful travel l_u
- V_{300a} = measured travel variation over 300 mm
- V_{ua} = measured travel variation over the useful travel

fig. 1

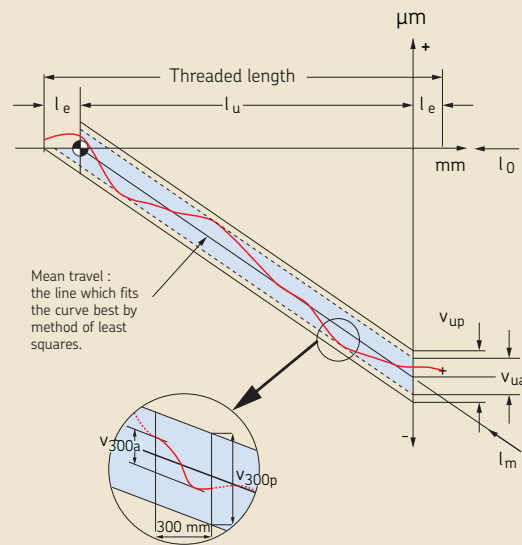

Case with value of c specified by the customer.

fig. 2

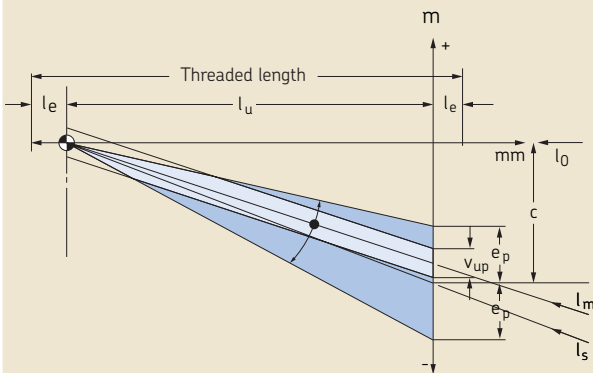

Case with $c = 0$ = standard version in case of no value given by the customer.

fig. 3

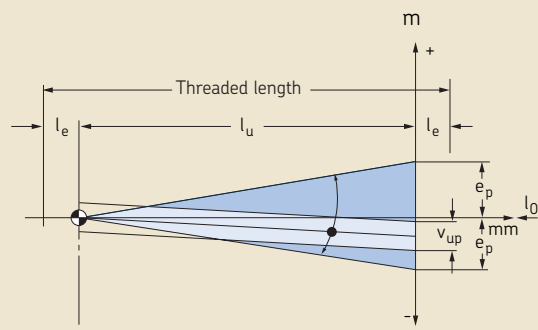

SD/BD miniature screws



Standard

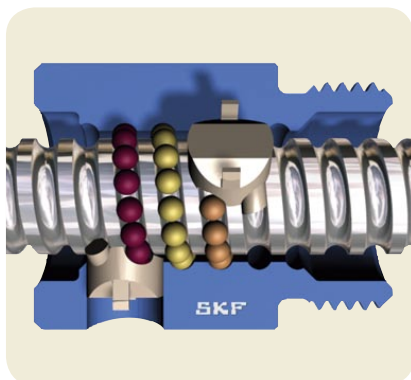

Recirculation



Customised

Smooth running and excellent backdriving with the new SD/BD internal recirculation nut.

- Nominal diameter 8 to 16 mm
- Lead: 2 to 10 mm
- Cylindrical nut with threaded end: easy mounting
- Excellent repeatability: high positioning quality
- Internal recirculation with inserts: smooth running and good backdriving
- Backlash elimination by oversize balls on request (BD designation): maximum length 1000 mm
- Optional safety device (*): 12x4R - 14x4R - 16x5R
- Optional wipers (*): For all sizes
- Corrosion resistant screw (see page 16)

(* It is not possible to supply safety device and wipers in the same nut.

Nominal diameter	Right hand lead	Maximum length	Basic load ratings		Number of circuits of balls	Maximum axial play	Reduced maximum axial play (on request)	Mass of nut	Mass of screw shaft	Inertia of one metre of screw shaft	Designation
			dynamic	static							
d_0	P_h		C_a	C_{0a}							
mm	mm	mm	kN	kN	—	mm	kg	kg/m	kgmm ²		
8	2,5	1000	2,2	2,6	3	0,07	0,03	0,025	0,32	2,1	SD/BD 8x2,5 R
10	2	1000	2,5	3,5	3	0,07	0,03	0,030	0,51	5,2	SD/BD 10x2 R
10	4	1000	4,5	5,4	3	0,07	0,03	0,040	0,43	3,8	SD/BD 10x4 R
12	2	2000	2,9	4,6	3	0,07	0,03	0,023	0,67	10,0	SD/BD 12x2 R
12	4	2000	5,0	6,5	3	0,07	0,03	0,066	0,71	10,8	SD/BD 12x4 R
12	5	2000	4,2	5,3	3	0,07	0,03	0,058	0,71	10,1	SD/BD 12x5 R
14	4	2000	6,0	9,0	3	0,07	0,03	0,083	1,05	22,0	SD/BD 14x4 R
16	2	2000	3,3	6,2	3	0,07	0,03	0,100	1,40	39,7	SD/BD 16x2 R
16	5	2000	7,6	10,5	3	0,07	0,03	0,135	1,30	33,9	SD/BD 16x5 R
16	10	2000	10,7	17,0	2x1,8	0,07	0,03	0,160	1,21	30,7	SD/BD 16x10 R

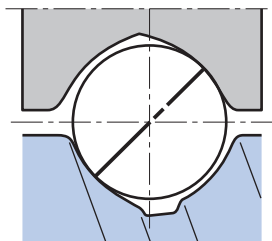

SD

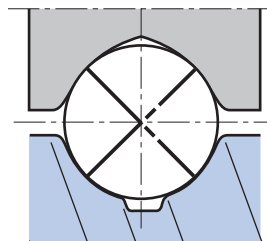

BD

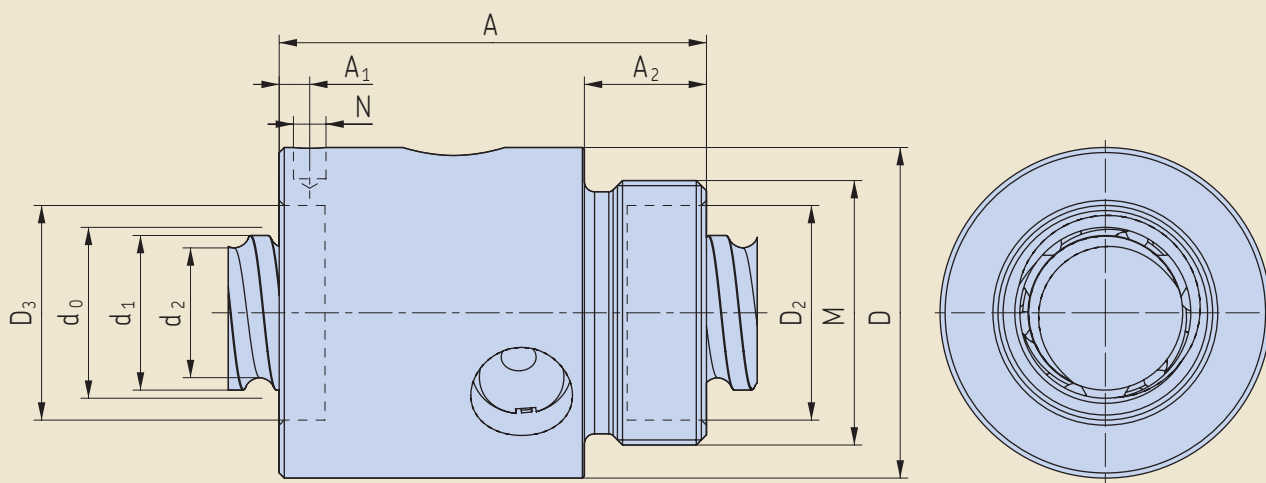

Designation	Screw shaft		Nut		Without wiper	With wipers	Tightening spanner			Without wiper		
	d_2	d_1	D h10	M 6g	A $\pm 0,3$	A_2	(FACOM)	N	$A_1 \pm 0,2$	D_2	D_3	
—	mm											
SD/BD 8x2,5 R	6,3	7,6	17,5	M15x1	23,5	23,5	7,5	126-A35	3,2	3	11,1	11,1
SD/BD 10x2 R	8,3	9,5	19,5	M17x1	22,0	22,0	7,5	126-A35	3,2	3	13,3	13,3
SD/BD 10x4 R	7,4	8,9	21,0	M18x1	28,0	-	8,0	126-A35	3,2	3	13,0	-
SD/BD 12x2 R	9,9	11,2	20,0	M18x1	20,0	23,5	8,0	126-A35	3,2	3	13,2	-
SD/BD 12x4 R	9,4	11,3	25,5	M20x1	34,0	34,0	10,0	126-A35	3,2	3	16,1	16,1
SD/BD 12x5 R	9,3	11,8	23,0	M20x1	36,0	40,0	10,0	126-A35	3,2	3	-	-
SD/BD 14x4 R	11,9	13,7	27,0	M22x1,5	30,0	34,0	8,0	126-A35	3,2	3	-	-
SD/BD 16x2 R	14,3	15,6	29,5	M25x1,5	27,0	27,0	12,0	126-A35	3,2	3	20,1	20,1
SD/BD 16x5 R	12,7	15,2	32,5	M26x1,5	42,0	42,0	12,0	126-A35	3,2	3	-	21,1
SD/BD 16x10 R	12,6	15,2	32,0	M26x1,5	46,0	46,0	12,0	126-A35	3,2	3	19,5	19,5

Designation: see page 49

SDS/BDS/SHS miniature screws in stainless steel

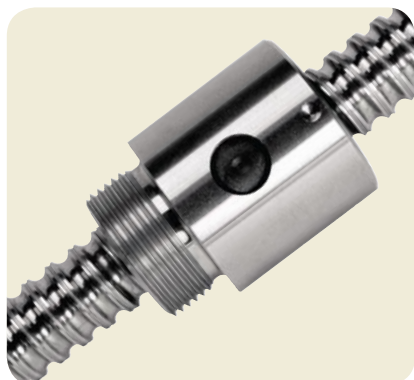

Standard SDS

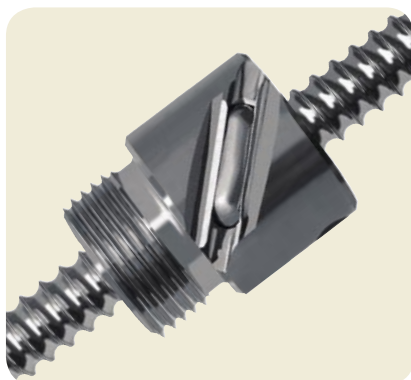

Standard SHS

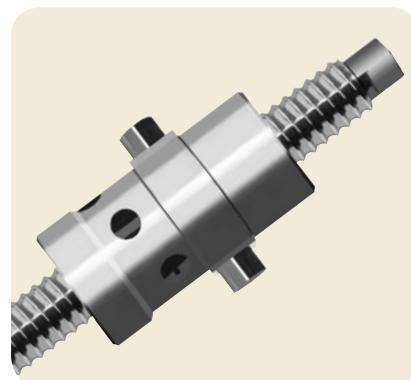

Customised SDS

- Nominal diameter
6 to 16 mm
- Lead: 2 to 5 mm
- Cylindrical nut with threaded end: easy mounting
- Excellent repeatability: high positioning quality
- Backlash elimination by oversize balls on request (BDS designation): maximum length 1000 mm
- Optional wipers:
For all sizes
- Material for both shaft and nut: X30Cr13 (AISI 420 equivalent)
- Balls are in X105CrMo17 (AISI 440C equivalent) except for size 16x5R (SDS/BDS): balls are in 100 Cr6 (AISI 52100 equivalent)

Nominal diameter	Right hand lead	Maximum length	Basic load ratings		Number of circuits of balls	Maximum axial play	Reduced maximum axial play (on request)	Mass of nut	Mass of screw shaft	Inertia of one metre of screw shaft	Designation
			dynamic	static							
d_0	P_h		C_a	C_{oa}							
mm	mm	mm	kN	kN	—	mm	kg	kg/m	kgmm ²		
6	2	1000	1,0	1,1	1 x 2,5	0,05	0,02	0,025	0,18	0,7	SHS 6x2 R
8	2,5	1000	1,2	1,3	3	0,07	0,03	0,024	0,32	2,1	SDS/BDS 8x2,5 R
10	2	1000	1,6	1,7	3	0,07	0,03	0,026	0,51	5,2	SDS/BDS 10x2 R
12	2	2000	1,8	2,2	3	0,07	0,03	0,028	0,67	10,0	SDS/BDS 12x2 R
12	4	2000	3,0	3,2	3	0,07	0,03	0,068	0,71	10,8	SDS/BDS 12x4 R
12	5	2000	2,5	2,6	3	0,07	0,03	0,061	0,71	10,1	SDS/BDS 12x5 R
14	4	2000	3,7	4,4	3	0,07	0,03	0,075	1,05	22,0	SDS/BDS 14x4 R
16	2	2000	2,0	3,0	3	0,07	0,03	0,066	1,40	39,7	SDS/BDS 16x2 R
16	5	2000	4,7	5,1	3	0,07	0,03	0,133	1,30	33,9	SDS/BDS 16x5 R

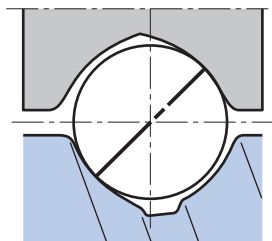

SDS

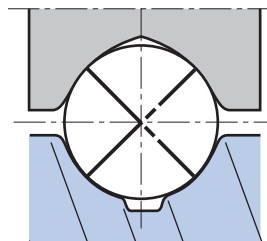

BDS

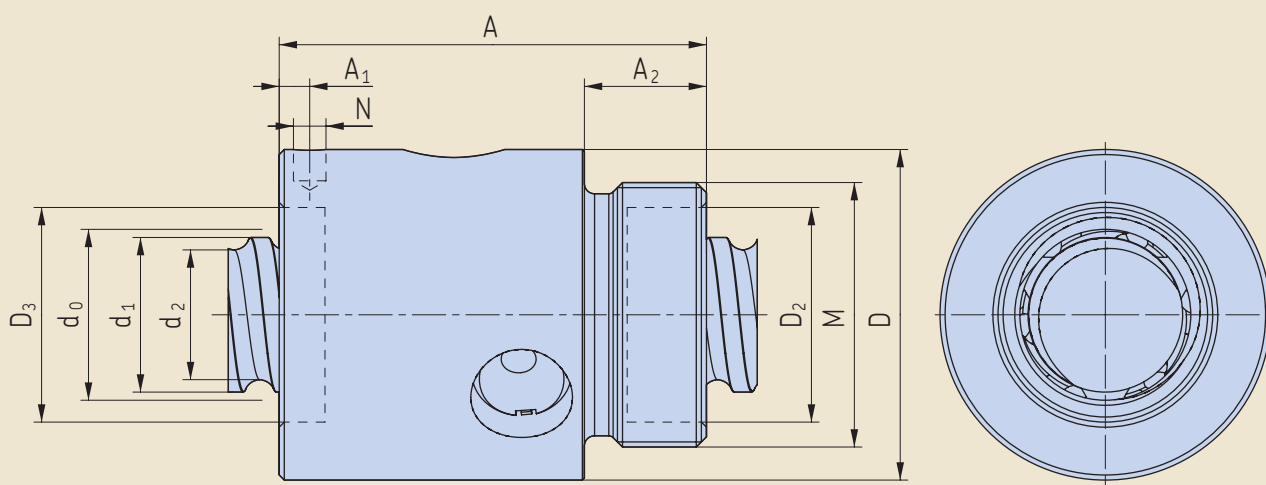

Designation	Screw shaft		Nut		Without wiper	With wipers	Tightening spanner		N	A ₁ ±0,2	Without wiper	
	d ₂	d ₁	D h10	M 6g	A ±0,3	A ₂	(FACOM)	D ₂			D ₃	
—	mm											
SHS 6x2 R	4,7	6,0	16,5	M14x1,0	20	-	7,5	126-A35	3,2	3	8,3	-
SDS/BDS 8x2,5 R	6,3	7,6	17,5	M15x1,0	23,5	23,5	7,5	126-A35	3,2	3	11,1	11,1
SDS/BDS 10x2 R	8,3	9,5	19,5	M17x1,0	22,0	22,0	7,5	126-A35	3,2	3	13,3	13,3
SDS/BDS 12x2 R	9,9	11,2	20,0	M18x1,0	23,5	23,5	8,0	126-A35	3,2	3	13,2	13,2
SDS/BDS 12x4 R	9,4	11,3	25,5	M20x1,0	34,0	34,0	10,0	126-A35	3,2	3	16,1	16,1
SDS/BDS 12x5 R	9,3	11,8	23,0	M20x1,0	40,0	40,0	10,0	126-A35	3,2	3	16,1	16,1
SDS/BDS 14x4 R	11,9	13,7	27,0	M22x1,5	34,0	34,0	8,0	126-A35	3,2	3	17,5	17,5
SDS/BDS 16x2 R	14,3	15,5	29,5	M25x1,5	27,0	27,0	12,0	126-A35	3,2	3	20,1	20,1
SDS/BDS 16x5 R	12,7	15,2	32,5	M26x1,5	42,0	42,0	12,0	126-A35	3,2	3	21,1	21,1

Designation: see page 49

SH miniature screws



Standard

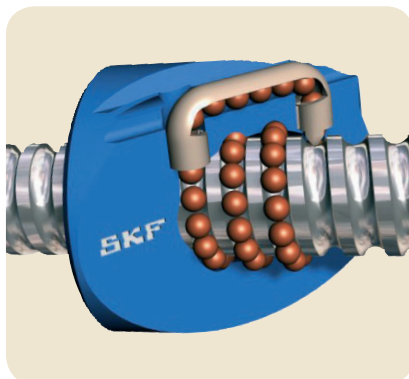

Recirculation

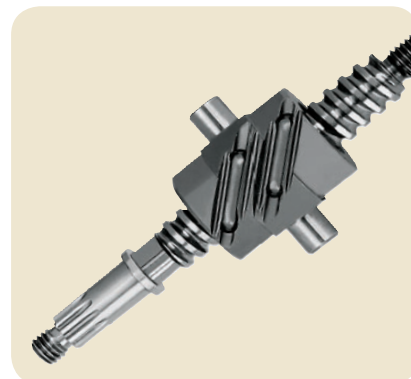

Customised

Rolled thread ball screw with ball recirculation by integrated tube.

- Nominal diameter 6 to 12,7 mm
- Lead: 2 to 12,7 mm
- Nut with threaded end for easy mounting
- High positioning accuracy
- Increased security: optional reinforced safety device available on request in size SH 12,7x12,7R
- Wipers available on request for size SH 12,7x12,7R

It is not possible to supply safety device and wipers in the same nut.

Nominal diameter	Right hand lead	Maximum length	Basic load ratings		Number of circuits of balls	Maximum axial play	Reduced maximum axial play (on request)	Mass of nut	Mass of screw shaft	Inertia of one metre of screw shaft	Designation
			dynamic	static							
d_0	P_h		C_a	C_{0a}							
mm	mm	mm	kN	kN	—	mm	mm	kg	kg/m	kgmm ²	
6	2	1000	1,2	1,5	1 x 2,5	0,05	0,02	0,025	0,18	0,7	SH 6 x 2 R
10	3	1000	2,3	3,5	1 x 2,5	0,07	0,03	0,050	0,50	5,1	SH 10 x 3 R
12,7	12,7	2000	5,3	9,0	2 x 1,5	0,07	0,03	0,200	0,71	16,2	SH 12,7 x 12,7 R

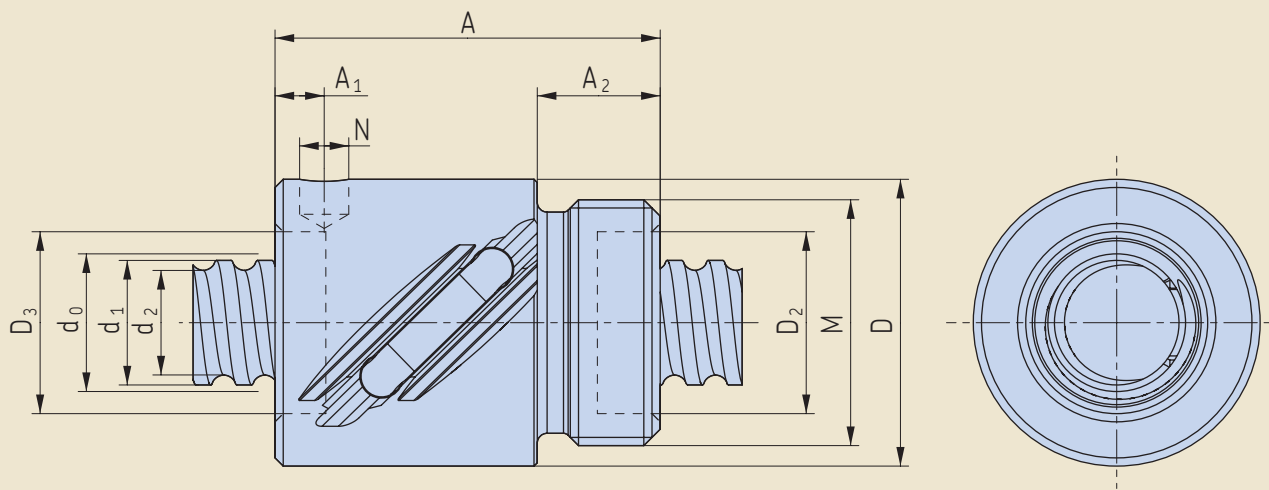

Designation	Screw shaft		Nut		A	A ₂	Tightening spanner (FACOM)	N	A ₁ ±0,2	Without wiper	
	d ₂	d ₁	D h10	M 6g						D ₂	D ₃
—	mm				—		—	mm			
SH 6 x 2 R	4,7	6,0	16,5	M14 x 1	20	7,5	126.A35	3,2	3	8,3	-
SH 10 x 3 R	7,9	9,9	21,0	M18 x 1	29	9,0	126.A35	3,2	3	14,1	14,1
SH 12,7 x 12,7 R	10,2	13,0	29,5	M25 x 1,5	50	12,0	126.A35	3,2	3	18,1	-

Designation: see page 49

SX/BX universal screws



Standard

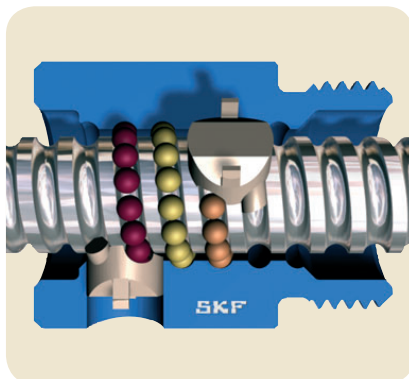

Recirculation



Customised

Rolled thread ball screw internal recirculation nut with threaded end.

Standard version: composite inserts

Special version: steel inserts which can act as a safety device for severe requirements or vertical applications
Contact us.

- Nominal diameter 20 to 63 mm
- Lead: 5 to 10 mm
- Cylindrical body of minimum diameter to simplify assembly
- Lubrication hole for nipple or automatic SKF system 24, positioned relative to the ISO thread
- Handling screw: nut with axial play
- Screw shaft can be phosphated on request
- Wipers available
- Backlash elimination by oversize balls on request (BX designation)
- Nut mounting flanges available
- Screw shaft accessories: FLBU - PLBU & BUF off the shelves. (see pages 40 to 45)

Nominal diameter	Right hand lead	Maximum length	Basic load ratings		Number of circuits of balls	Maximum axial play	Reduced maximum axial play (on request)	Preload torque BX average T_{pr}	Mass of nut	Mass of screw shaft	Inertia of one metre of screw shaft	Designation
			dynamic	static								
d_0	P_h		C_a	C_{oa}								
mm	mm	mm	kN	kN	—	mm	mm	Nm	kg	kg/m	kgmm ²	
20	5	4700	14,5	24,4	4	0,10	0,05	0,10	0,27	2,0	85	SX/BX 20 x 5 R
25	5	4700	19,4	37,8	5	0,10	0,05	0,17	0,49	3,3	224	SX/BX 25 x 5 R
25	10	4700	25,8	43,7	4	0,12	0,08	0,23	0,56	3,2	255	SX/BX 25 x 10 R
32	5	5700	22,1	50,5	5	0,10	0,05	0,25	0,55	5,6	641	SX/BX 32 x 5 R
32	10	5700	28,9	55,7	4	0,12	0,08	0,32	0,79	5,6	639	SX/BX 32 x 10 R
40	5	5700	24,1	63,2	5	0,10	0,05	0,34	0,66	9,0	1639	SX/BX 40 x 5 R
40	10	5700	63,6	127,1	5	0,12	0,08	0,64	1,35	8,4	1437	SX/BX 40 x 10 R
50	10	5700	81,9	189,1	6	0,12	0,08	1,02	2,10	13,6	3736	SX/BX 50 x 10 R
63	10	5700	91,7	243,5	6	0,12	0,08	1,44	2,90	22,0	9913	SX/BX 63 x 10 R

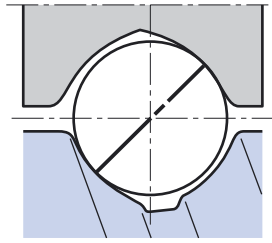

SX

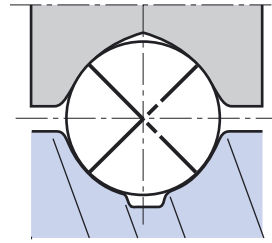

BX

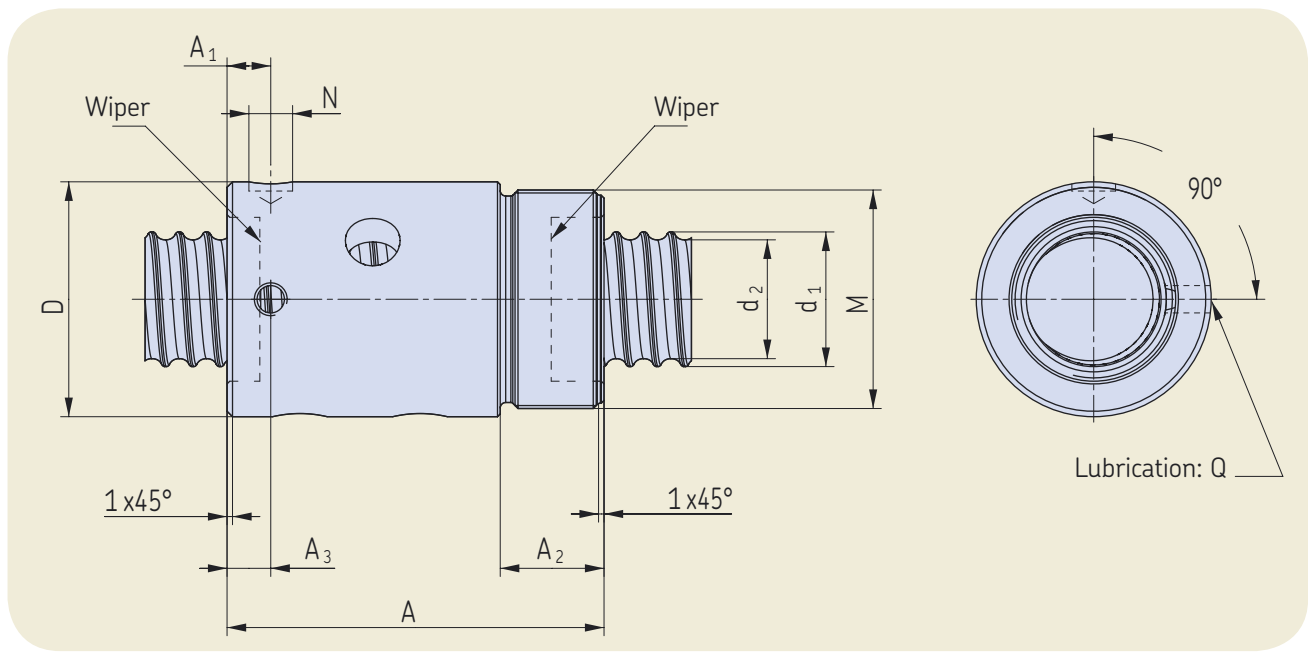

Designation	Screw shaft		Nut		Lubrication hole			Tightening spanner			
	d_2	d_1	D js13	M 6g	A	A_2	Q	A_3	N	A_1	
—	mm							mm			
SX/BX 20 x 5 R	16,7	19,4	38	M35 x 1,5	54	14	M6 x 1	8	HN5	8	8
SX/BX 25 x 5 R	21,7	24,6	43	M40 x 1,5	69	19	M6 x 1	8	HN6	8	8
SX/BX 25 x 10 R	20,5	24,6	43	M40 x 1,5	84	19	M6 x 1	12	HN6	8	12
SX/BX 32 x 5 R	28,7	31,6	52	M48 x 1,5	64	19	M6 x 1	8	HN7	8	8
SX/BX 32 x 10 R	27,8	32,0	54	M48 x 1,5	95	19	M6 x 1	15	HN7	8	15
SX/BX 40 x 5 R	36,7	39,6	60	M56 x 1,5	65	19	M6 x 1	8	HN9	8	8
SX/BX 40 x 10 R	34,0	39,4	65	M60 x 2,0	105	24	M8 x 1	13	HN9	8	15
SX/BX 50 x 10 R	44,0	49,7	78	M72 x 2,0	135	29	M8 x 1	15	HN12	8	15
SX/BX 63 x 10 R	57,0	62,8	93	M85 x 2,0	135	29	M8 x 1	15	HN14	8	15

Designation: see page 49

FHRF round flanges for SX/BX nuts



SX nut

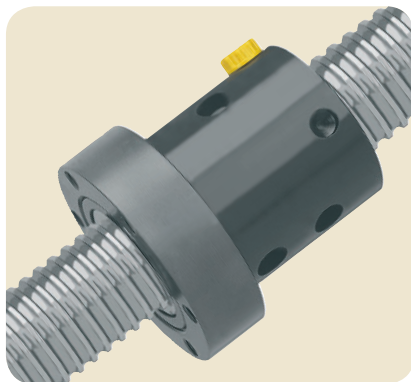

SX nut with flange

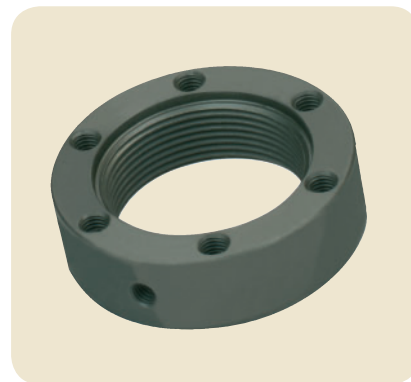

Flange

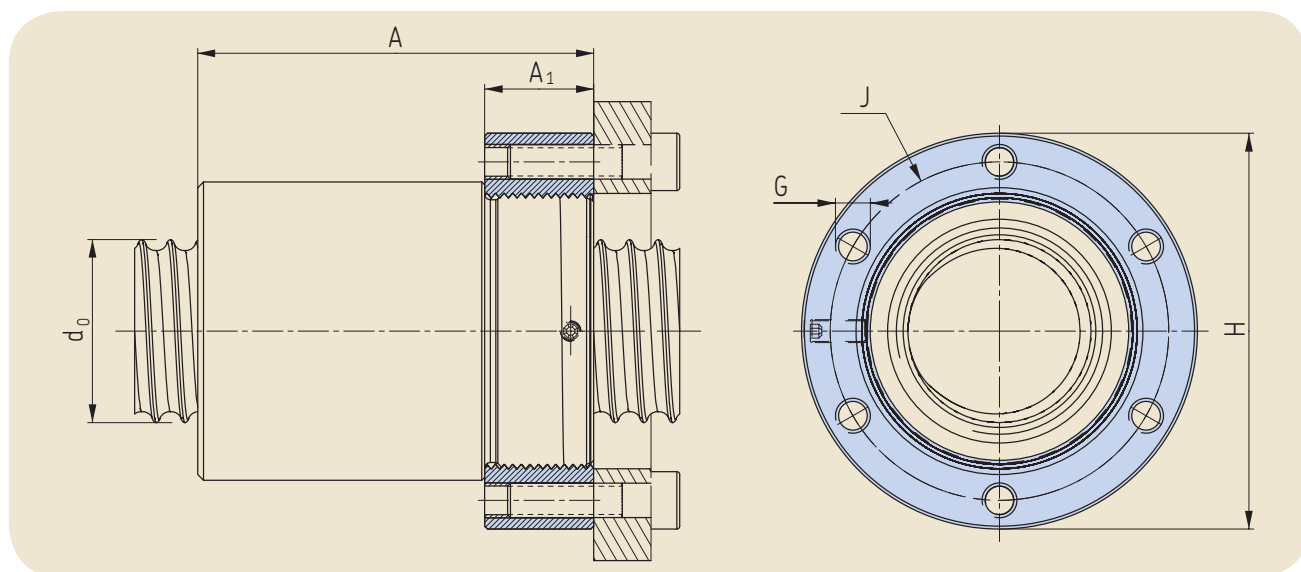

Nominal diameter		Dimensions					Designation
d_0	P_h	A h14	A_1 h14	G	H h12	J js12	
mm							
20	5	55	15	M5	52	44	FHRF 20
25	5	70	20	M6	60	50	FHRF 25
25	10	88	20	M6	60	50	FHRF 25
32	5	70	20	M6	69	59	FHRF 32
32	10	96	20	M6	69	59	FHRF 32
40	5	70	20	M8	82	69	FHRF 40 x 5
40	10	111	25	M10	92	76	FHRF 40 x 10
50	10	136	30	M12	110	91	FHRF 50
63	10	136	30	M12	125	106	FHRF 63

FHSF square flanges for SX/BX nuts



SX nut

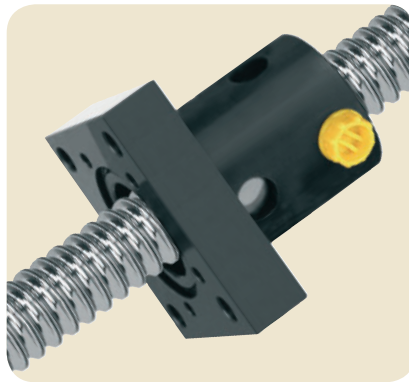

SX nut with flange

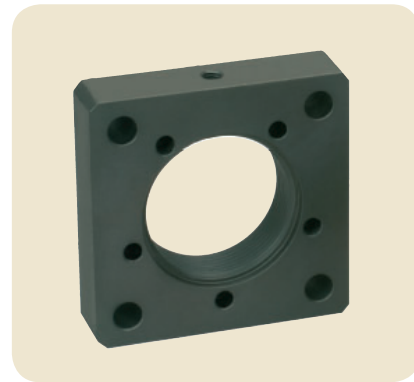

Flange

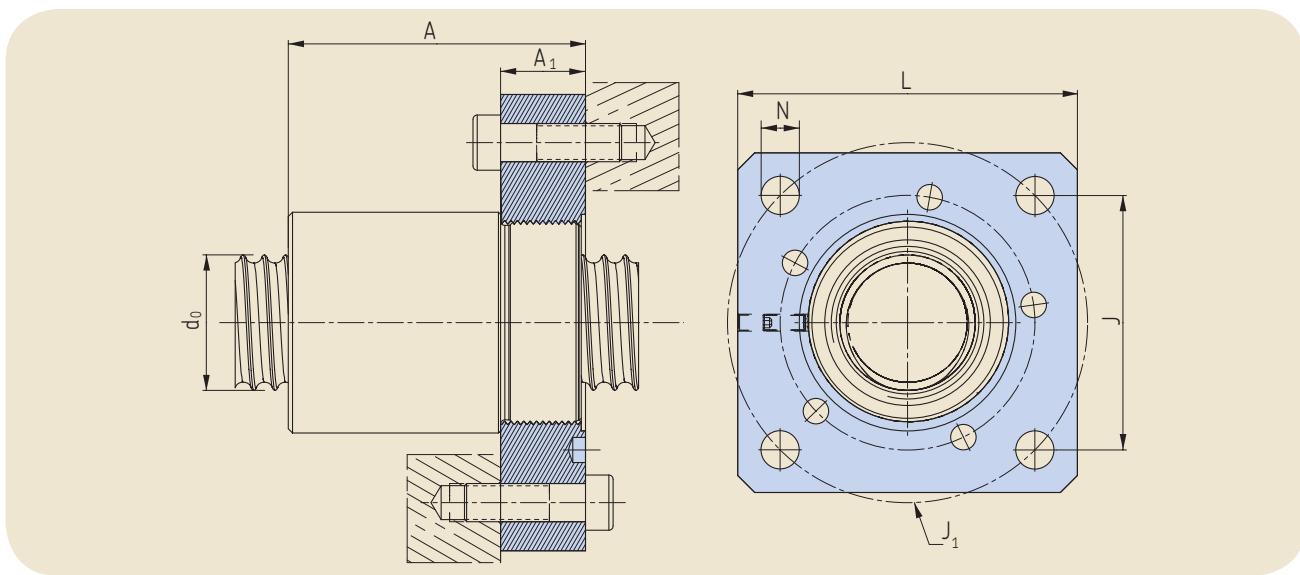

Nominal diameter		Dimensions						Designation
d_0	P_h	A h14	A_1 h14	L h14	J js12	J_1	N	
mm								
20	5	55	15	60	45	63,6	6,6	FHSF 20
25	5	70	20	70	52	73,5	9,0	FHSF 25
25	10	88	20	70	52	73,5	9,0	FHSF 25
32	5	70	20	80	60	84,8	9,0	FHSF 32
32	10	96	20	80	60	84,8	9,0	FHSF 32
40	5	70	20	90	70	99,0	11,0	FHSF 40 x 5
40	10	111	25	100	78	110,3	13,0	FHSF 40 x 10
50	10	136	30	120	94	133,0	15,0	FHSF 50
63	10	136	30	130	104	147,0	15,0	FHSF 63

On special request, trunnion flanges are available.

SND/BND precision screws, DIN standard 69051



Standard

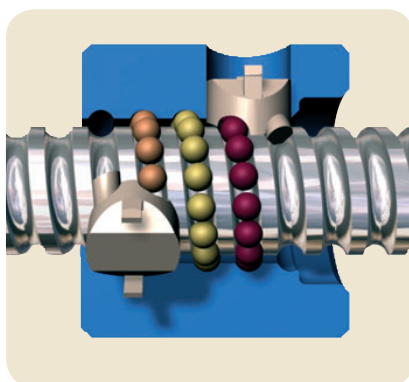

Recirculation



With flanged housing

Rolled thread ball screw with internal recirculation nut.

Standard version: composite inserts

Special version: steel inserts which can act as a safety device for severe requirements or vertical applications
Contact us.

- Nominal diameter 16 to 63 mm
- Lead: 5 to 10 mm
- Lubrication hole for nipple or automatic SKF system 24
- Compact nut with integral flange for simple mounting and axial play
- Ground flanged nut: precise mounting
- Wipers available
- Backlash elimination by oversize balls on request (BND designation)
- Screw shaft can be phosphated on request
- Screw shaft accessories: FLBU - PLBU & BUF off the shelves (see pages 40 to 45)

Nominal diameter	Right hand lead	Maximum length	Basic load ratings		Number of circuits of balls	Maximum axial play	Reduced maximum axial play (on request)	Preload torque BND average	Mass of nut	Mass of screw shaft	Inertia of one metre of screw shaft	Designation
			dynamic	static								
d_0	P_h		C_a	C_{oa}			T_{pr}					
mm	mm	mm	kN	kN	—	mm	mm	Nm	kg	kg/m	kgmm ²	
16	5	2000	8,1	12,4	3	0,08	0,05	0,05	0,23	1,30	33,0	SND/BND 16 x 5 R
16	10	2000	10,7	17,0	2x1,8	0,07	0,03	0,15	0,18	1,21	30,7	SND/BND 16 x 10 R
20	5	4700	11,7	18,3	3	0,10	0,05	0,08	0,24	2,00	85,0	SND/BND 20 x 5 R
25	5	4700	13,0	22,7	3	0,10	0,05	0,11	0,29	3,30	224,0	SND/BND 25 x 5 R
25	10	4700	25,8	43,7	4	0,12	0,08	0,23	0,46	3,50	255,0	SND/BND 25 x 10 R
32	5	5700	19,1	40,4	4	0,10	0,05	0,21	0,45	5,60	641,0	SND/BND 32 x 5 R
32	10	5700	22,6	41,8	3	0,12	0,08	0,25	0,83	5,60	639,0	SND/BND 32 x 10 R
40	5	5700	25,4	63,2	5	0,10	0,05	0,36	0,65	9,00	1639,0	SND/BND 40 x 5 R
40	10	5700	63,6	127,1	5	0,12	0,08	0,64	1,33	8,40	1437,0	SND/BND 40 x 10 R
50	10	5700	70,6	157,6	5	0,12	0,08	0,88	1,72	13,60	3736,0	SND/BND 50 x 10 R
63	10	5700	78,4	202,9	5	0,12	0,08	1,23	2,23	22,00	9913,0	SND/BND 63 x 10 R

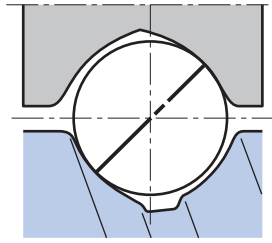

SND

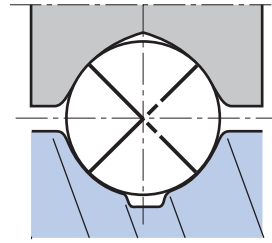

BND

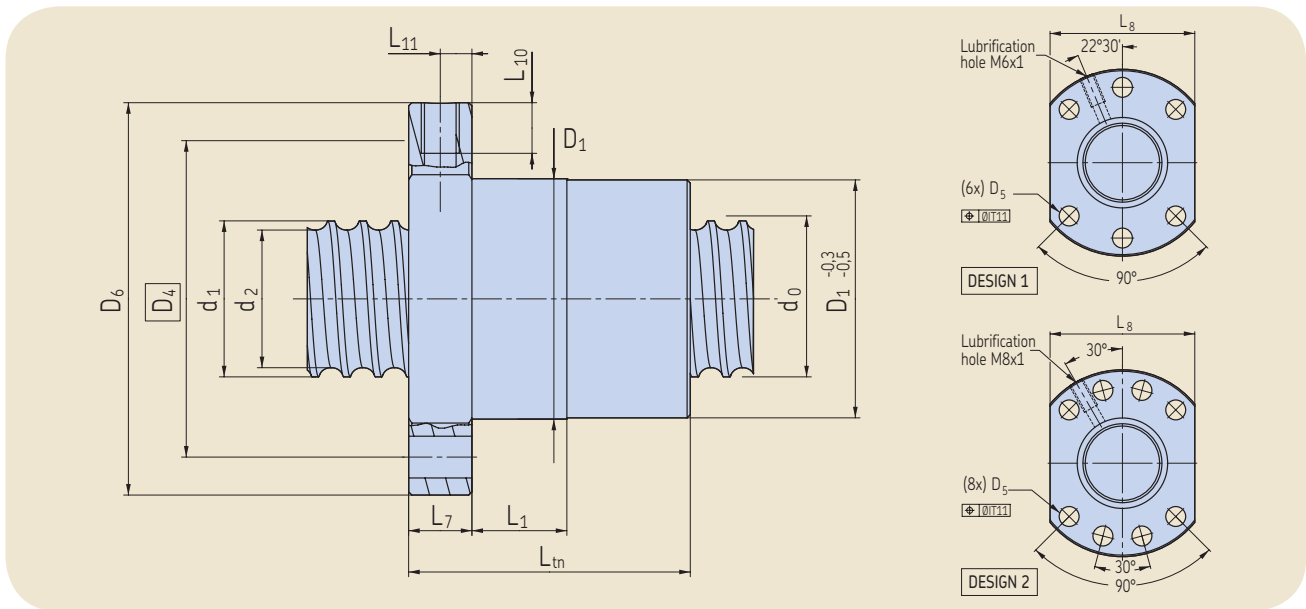

Designation	Screw shaft		Nut										Design
	d_2	d_1	D_1 g6	D_4	D_5 H13	D_6 h13	L_{tn}	L_1	L_7	L_8 h13	L_{10}	L_{11}	
—	mm												
SND/BND 16 x 5 R	12,7	15,2	28	38	5,5	48	43,5	10	10	40	8	5	1
SND/BND 16 x 10 R	12,6	15,2	28	28	5,5	48	47,0	37	10	40	8	5	1
SND/BND 20 x 5 R	16,7	19,4	36	47	6,6	58	44,5	10	10	44	8	5	1
SND/BND 25 x 5 R	21,7	24,6	40	51	6,6	62	44,5	10	10	48	8	5	1
SND/BND 25 x 10 R	20,5	24,6	40	51	6,6	62	75,0	10	10	48	8	5	1
SND/BND 32 x 5 R	28,7	31,6	50	65	9,0	80	51,5	10	12	62	8	6	1
SND/BND 32 x 10 R	27,8	32,0	50	65	9,0	80	69,0	10	12	62	8	6	1
SND/BND 40 x 5 R	36,7	39,6	63	78	9,0	93	58,5	10	14	70	10	7	2
SND/BND 40 x 10 R	34,0	39,4	63	78	9,0	93	91,0	20	14	70	10	7	2
SND/BND 50 x 10 R	44,0	49,7	75	93	11,0	110	93,0	10	16	85	10	8	2
SND/BND 63 x 10 R	57,0	62,8	90	108	11,0	125	95,0	10	18	95	10	9	2

Designation: see page 49

PND preloaded screws, DIN standard 69051



Standard

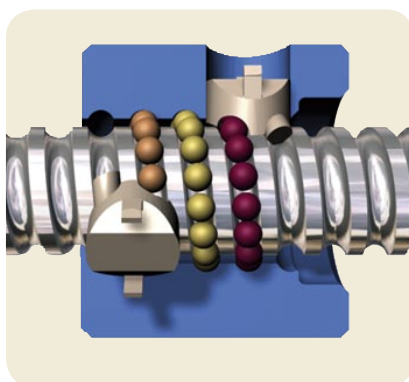

Recirculation

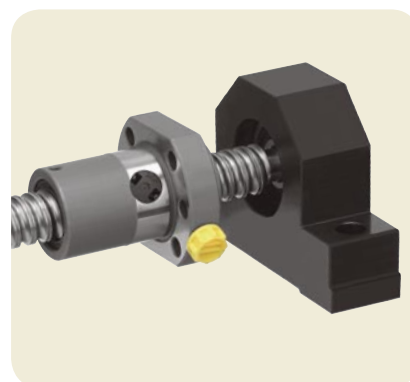

With plummer housing

Rolled thread ball screw with internal recirculation nut.

Standard version: composite inserts

Special version: steel inserts which can act as a safety device for severe requirements or vertical applications
Contact us.

- Nominal diameter 16 to 63 mm
- Lead: 5 to 10 mm
- Lubrication hole for nipple or automatic SKF system 24
- One-piece nut with integral flange offering an internal preload for optimum rigidity
- Wipers available
- Screw shaft can be phosphated on request
- Screw shaft accessories: FLBU - PLBU & BUF off the shelves (see pages 40 to 45)

Nominal diameter	Right hand lead	Maximum length	Basic load ratings		Number of circuits of balls	Preload torque average	Mass of nut	Mass of screw shaft	Inertia of one metre of screw shaft	Designation Preload for optimum rigidity
			dynamic	static						
d_0	P_h		C_a	C_{0a}		T_{pr}				
mm	mm	mm	kN	kN	—	Nm	kg	kg/m	kgmm ²	—
16	5	2000	5,7	8,3	2 x 2	0,08	0,22	1,30	33,0	PND 16 x 5 R
16	10	1000	10,7	17,0	2 x 2 x 1,8	0,25	0,28	1,21	30,7	PND 16 x 10 R
20	5	4700	8,2	12,2	2 x 2	0,14	0,34	2,00	85,0	PND 20 x 5 R
25	5	4700	13,0	22,7	2 x 3	0,28	0,44	3,30	224,0	PND 25 x 5 R
25	10	4700	14,2	21,8	2 x 2	0,30	0,49	3,50	255,0	PND 25 x 10 R
32	5	5700	19,1	40,4	2 x 4	0,52	0,84	5,60	641,0	PND 32 x 5 R
32	10	5700	22,6	41,8	2 x 3	0,61	0,92	5,60	639,0	PND 32 x 10 R
40	5	5700	25,4	63,2	2 x 5	0,71	1,51	9,00	1639,0	PND 40 x 5 R
40	10	5700	52,5	101,7	2 x 4	1,47	2,01	8,40	1437,0	PND 40 x 10 R
50	10	5700	70,6	157,6	2 x 5	2,47	3,21	13,60	3736,0	PND 50 x 10 R
63	10	5700	78,4	202,9	2 x 5	3,46	4,28	22,00	9913,0	PND 63 x 10 R

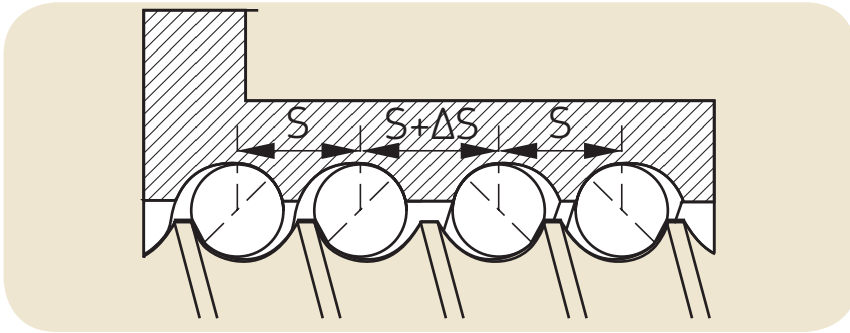

Preload

A displacement Δs is ground into the nut ball track between the two series of recirculation inserts: this displacement is made in an unused part of the track. The balls thus have two points of contact even under small external loads.

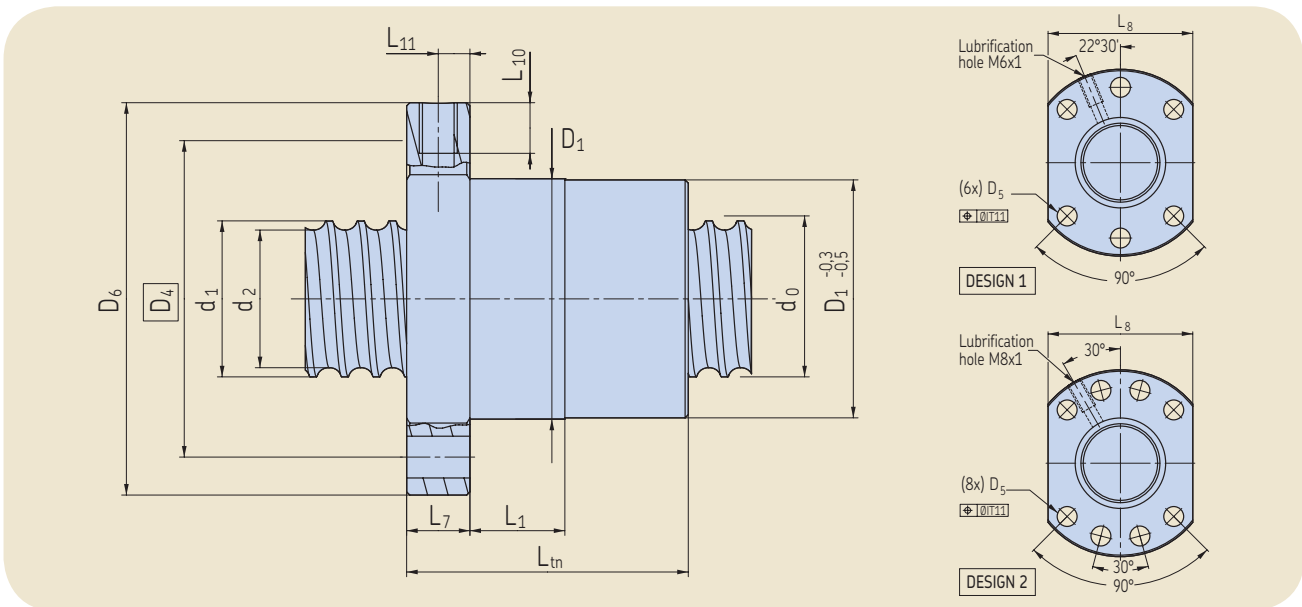

Designation	Screw shaft		Nut										Design
	d_2	d_1	D_1 g6	D_4	D_5 H13	D_6 h13	L_{tn}	L_1	L_7	L_8 h13	L_{10}	L_{11}	
—	mm												
PND 16 x 5 R	12,7	15,2	28	38	5,5	48	48	10	10	40	8	5	1
PND 16 x 10 R	12,6	15,2	28	38	5,5	48	87	77	10	40	8	5	1
PND 20 x 5R	16,7	19,4	36	47	6,6	58	50	10	10	44	8	5	1
PND 25 x 5 R	21,7	24,6	40	51	6,6	62	62	10	10	48	8	5	1
PND 25 x 10 R	20,5	24,6	40	51	6,6	62	75	10	10	48	8	5	1
PND 32 x 5 R	28,7	31,6	50	65	9,0	80	74	10	12	62	8	6	1
PND 32 x 10 R	27,8	32,0	50	65	9,0	80	102	10	12	62	8	6	1
PND 40 x 5 R	36,7	39,6	63	78	9,0	93	88	10	14	70	10	7	2
PND 40 x 10 R	34,0	39,4	63	78	9,0	93	130	20	14	70	10	7	2
PND 50 x 10 R	44,0	49,7	75	93	11,0	110	155	10	16	85	10	8	2
PND 63 x 10 R	57,0	62,8	90	108	11,0	125	157	10	18	95	10	9	2

Designation: see page 49

SN/BN precision screws

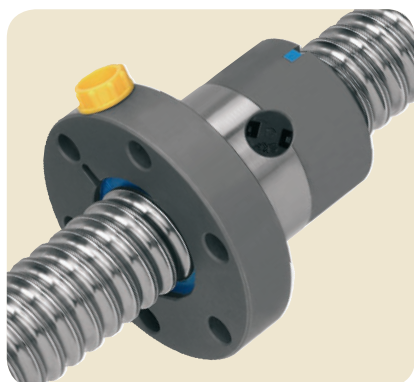

Standard

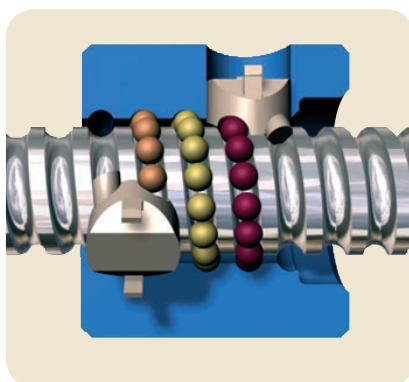

Recirculation



Customised

Rolled thread ball screw with internal recirculation nut.

Standard version: composite inserts

Special version: steel inserts which can act as a safety device for severe requirements or vertical applications

Contact us.

- Nominal diameter 16 to 63 mm
- Lead: 5 to 10 mm
- Lubrication hole for nipple or automatic SKF system 24
- Compact nut with integral flange for simple mounting and axial play
- Ground flanged nut: precise mounting
- Wipers available
- Backlash elimination by oversize balls on request (BN designation)
- Screw shaft can be phosphated on request
- Screw shaft accessories: FLBU - PLBU & BUF off the shelves (see pages 40 to 45)

Nominal diameter	Right hand lead	Maximum length	Basic load ratings		Number of circuits of balls	Maximum axial play	Reduced maximum axial play (on request)	Preload torque BN average T_{pr}	Mass of nut	Mass of screw shaft	Inertia of one metre of screw shaft	Designation
			dynamic C_a	static C_{oa}								
d_0	P_h		kN	kN	—	mm	mm	Nm	kg	kg/m	kgmm ²	
16	5	2000	8,1	12,4	3	0,08	0,05	0,05	0,25	1,3	33	SN/BN 16 x 5 R
20	5	4700	11,7	18,3	3	0,10	0,05	0,08	0,31	2,0	85	SN/BN 20 x 5 R
25	5	4700	13,0	22,7	3	0,10	0,05	0,11	0,34	3,3	224	SN/BN 25 x 5 R
25	10	4700	25,8	43,7	4	0,12	0,08	0,23	0,68	3,5	255	SN/BN 25 x 10 R
32	5	5700	19,1	40,4	4	0,10	0,05	0,21	0,44	5,6	641	SN/BN 32 x 5 R
32	10	5700	22,6	41,8	3	0,12	0,08	0,25	1,10	5,6	639	SN/BN 32 x 10 R
40	5	5700	25,4	63,2	5	0,10	0,05	0,36	0,62	9,0	1639	SN/BN 40 x 5 R
40	10	5700	63,6	127,1	5	0,12	0,08	0,64	1,62	8,4	1437	SN/BN 40 x 10 R
50	10	5700	70,6	157,6	5	0,12	0,08	0,88	1,95	13,6	3736	SN/BN 50 x 10 R
63	10	5700	78,4	202,9	5	0,12	0,08	1,23	2,70	22,0	9913	SN/BN 63 x 10 R

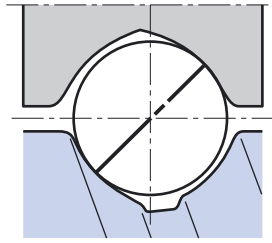

SN

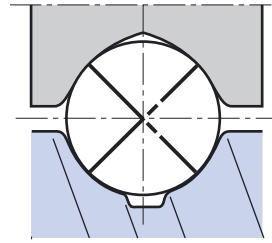

BN

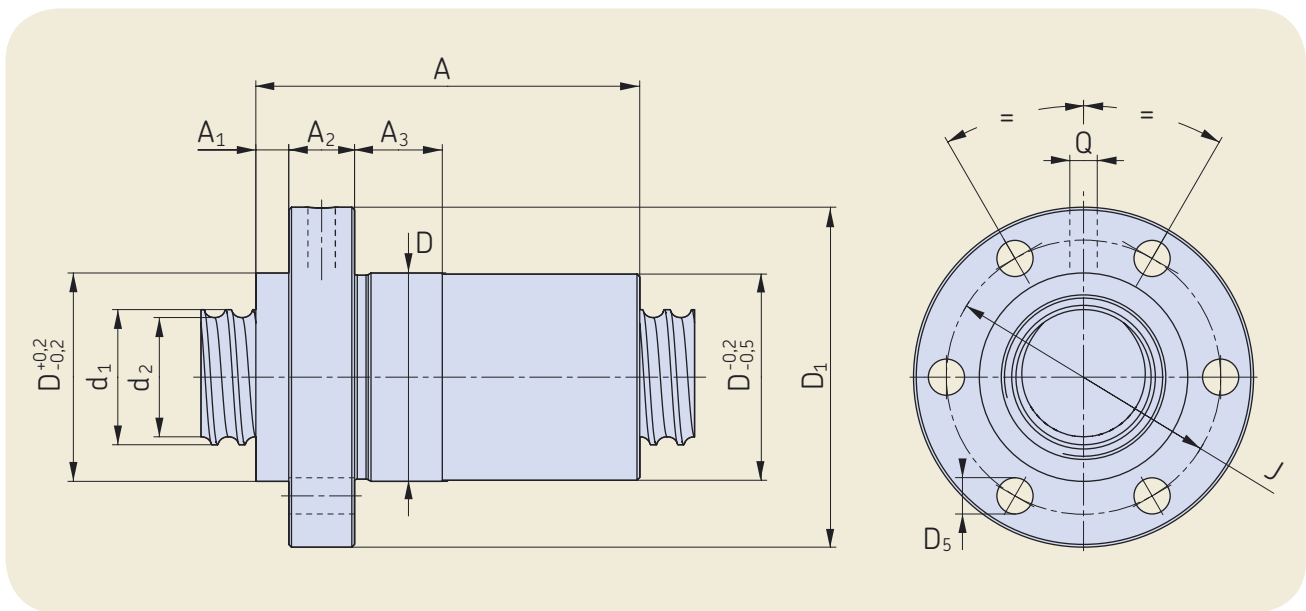

Designation	Screw shaft		Nut				Lubrication hole				
	d_2	d_1	D_{g9}	D_1	A_3	A	A_2	A_1	J_{js12}	D_5	Q
—	mm										
SN/BN 16 x 5 R	12,7	15,2	28	48	11	43,5	10	0	38	6 x 5.5	M6
SN/BN 20 x 5 R	16,7	19,4	33	57	15	46,5	12	0	45	6 x 6.6	M6
SN/BN 25 x 5 R	21,7	24,6	38	62	15	46,5	12	0	50	6 x 6.6	M6
SN/BN 25 x 10 R	20,5	24,6	43	67	10	75,0	10	0	55	6 x 6.6	M6
SN/BN 32 x 5 R	28,7	31,6	45	70	15	51,5	12	0	58	6 x 6.6	M6
SN/BN 32 x 10 R	27,8	32,0	54	87	20	79,0	16	6	70	6 x 9.0	M8 x 1
SN/BN 40 x 5 R	36,7	39,6	53	80	15	58,5	14	0	68	6 x 6.6	M6
SN/BN 40 x 10 R	34,0	39,4	63	95	20	93,0	16	0	78	6 x 9.0	M8 x 1
SN/BN 50 x 10 R	44,0	49,7	72	110	20	99,0	16	6	90	6 x 11	M8 x 1
SN/BN 63 x 10 R	57,0	62,8	85	125	20	103,0	20	6	105	6 x 11	M8 x 1

Designation: see page 49

PN preloaded screws

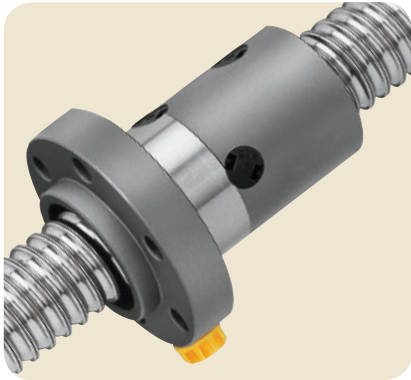

Standard

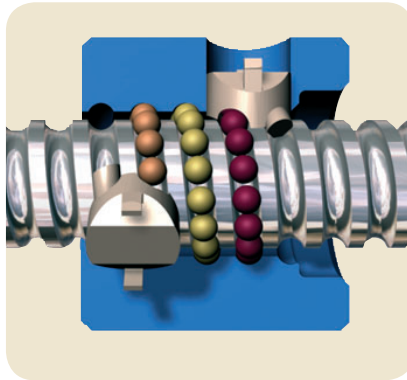

Recirculation



Customised

Rolled thread ball screw with internal recirculation nut.

Standard version: composite inserts

Special version: steel inserts which can act as a safety device for severe requirements or vertical applications
Contact us.

- Nominal diameter 16 to 63 mm
- Lead: 5 to 10 mm
- Lubrication hole for nipple or automatic SKF system 24
- One-piece nut with integral flange offering an internal preload for optimum rigidity

- Wipers available
- Screw shaft can be phosphated on request
- Screw shaft accessories: FLBU - PLBU & BUF off the shelves (see pages 40 to 45)

Nominal diameter	Right hand lead	Maximum length	Basic load ratings		Number of circuits of balls	Preload torque PN average T_{pr}	Mass of nut	Mass of screw shaft	Inertia of one metre of screw shaft	Designation Preload for optimum rigidity
			dynamic	static						
d_0	P_h		C_a	C_{0a}						
mm	mm	mm	kN	kN	—	Nm	kg	kg/m	kgmm ²	—
16	5	2000	5,7	8,3	2 x 2	0,08	0,25	1,3	33	PN 16 x 5 R
20	5	4700	8,2	12,2	2 x 2	0,14	0,37	2,0	85	PN 20 x 5 R
25	5	4700	13,0	22,7	2 x 3	0,28	0,41	3,3	224	PN 25 x 5 R
25	10	4700	14,2	21,8	2 x 2	0,30	0,68	3,5	255	PN 25 x 10 R
32	5	5700	19,1	40,4	2 x 4	0,52	0,56	5,6	641	PN 32 x 5 R
32	10	5700	22,6	41,8	2 x 3	0,61	1,47	5,6	639	PN 32 x 10 R
40	5	5700	25,4	63,2	2 x 5	0,71	0,81	9,0	1639	PN 40 x 5 R
40	10	5700	52,5	101,7	2 x 4	1,47	2,08	8,4	1437	PN 40 x 10 R
50	10	5700	70,6	157,6	2 x 5	2,47	2,54	13,6	3736	PN 50 x 10 R
63	10	5700	78,4	202,9	2 x 5	3,46	3,50	22,0	9913	PN 63 x 10 R

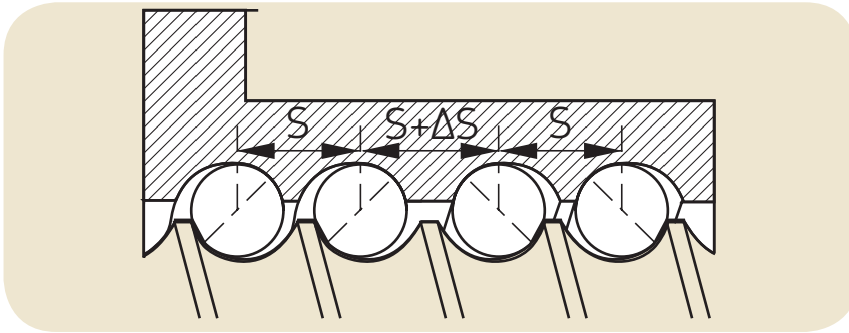

Preload

A displacement Δs is ground into the nut ball track between the two series of recirculation inserts: this displacement is made in an unused part of the track. The balls thus have two points of contact even under small external loads.

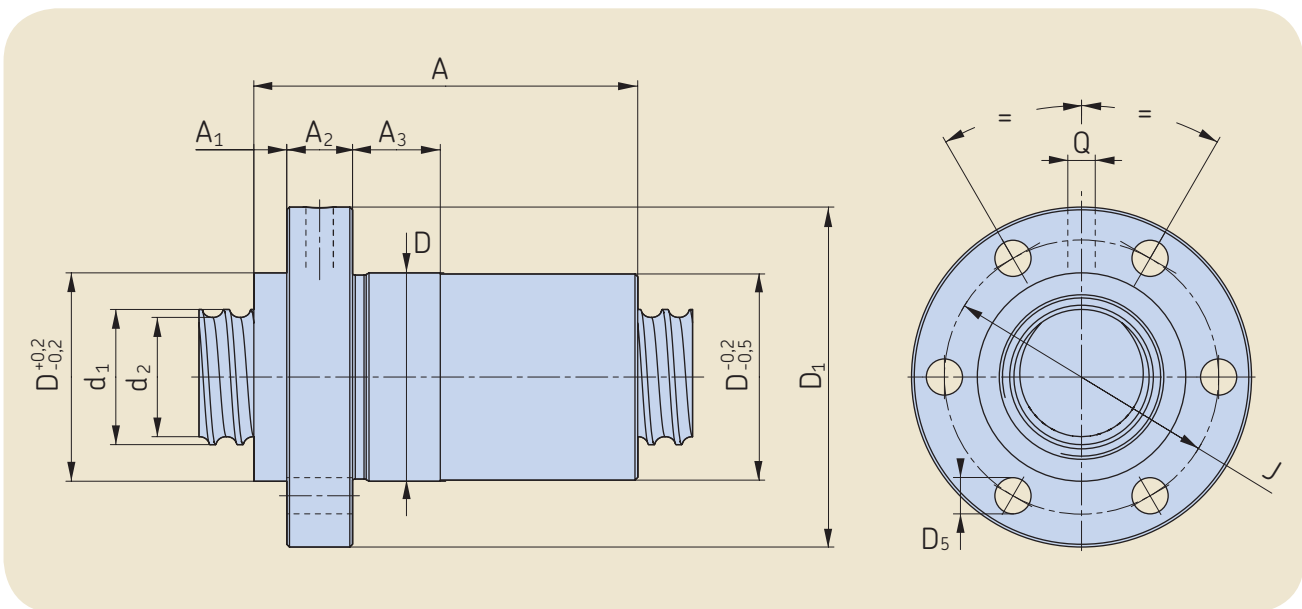

Designation	Screw shaft		Nut				Lubrication hole				
	d_2	d_1	D_{g9}	D_1	A	A_3	A_2	A_1	J _{js12}	D_5	Q
—	mm										
PN 16 x 5 R	12,7	15,2	28	48	48	11	10	0	38	6 x 5.5	M6
PN 20 x 5 R	16,7	19,4	33	57	52	15	12	0	45	6 x 6.6	M6
PN 25 x 5 R	21,7	24,6	38	62	64	15	12	0	50	6 x 6.6	M6
PN 25 x 10 R	20,5	24,6	43	67	75	10	10	0	55	6 x 6.6	M6
PN 32 x 5 R	28,7	31,6	45	70	74	15	12	0	58	6 x 6.6	M6
PN 32 x 10 R	27,8	32,0	54	87	113	20	16	6	70	6 x 9.0	M8 x 1
PN 40 x 5 R	36,7	39,6	53	80	88	15	14	0	68	6 x 6.6	M6
PN 40 x 10 R	34,0	39,4	63	95	128	20	16	0	78	6 x 9.0	M8 x 1
PN 50 x 10 R	44,0	49,7	72	110	157	20	16	6	90	6 x 11	M8 x 1
PN 63 x 10 R	57,0	62,8	85	125	161	20	20	6	105	6 x 11	M8 x 1

Designation: see page 49

SL/BL long lead screws

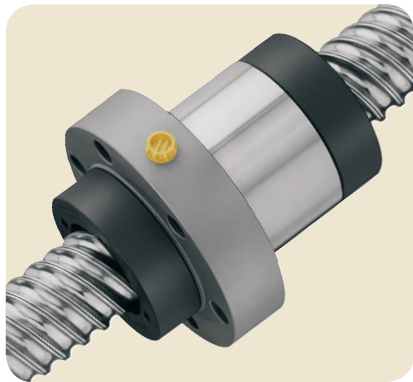

Standard

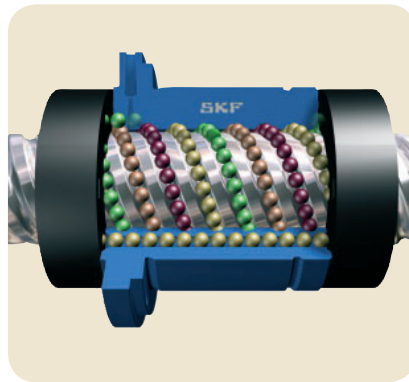

Recirculation



Customised

A new ball circulation system allowing high linear speed and low noise level.

- Nominal diameter 25 to 50 mm
- Lead: 20 to 50 mm
- Lubrication hole for nipple or automatic SKF system 24
- Two versions:
 - nut with axial play "SL"
 - nut with backlash elimination by oversize balls "BL"
- Double protection with polyamide wipers and brush wipers (WPR = with brush wipers NOWPR = without brush wipers)
- Screw shaft can be phosphated on request
- Screw shaft accessories: FLBU - PLBU & BUF off the shelves (see pages 40 to 45)

Nominal diameter	Right hand lead	Maximum length	Number of circuits of balls	Basic load ratings		SL	BL	Mass of nut	Mass of screw shaft	Inertia of one metre of screw shaft	Designation
				C_a	C_{oa}	Maximum axial play	Preload torque BL average				
d_0	P_h					S_{ap}	T_{pr}				
mm	mm	mm		kN	kN	mm	Nm	kg	kg/m	kgmm ² /m	
25	20	4700	4 x 1,7	23,0	51,6	0,08	0,20	0,6	3,3	215	SL/BL 25 x 20 R
25	25	4700	4 x 1,7	22,6	51,0	0,08	0,20	0,7	3,2	210	SL/BL 25 x 25 R
32	20	5700	4 x 1,7	25,7	65,3	0,08	0,29	0,8	5,1	530	SL/BL 32 x 20 R
32	32	5700	4 x 1,8	26,0	68,3	0,08	0,29	1,0	5,4	600	SL/BL 32 x 32 R
32	32	5700	4 x 1,8	26,0	68,3	0,08	0,29	0,9	5,4	600	SLD/BLD 32 x 32 R
32	40	5700	4 x 0,8	15,7	38,6	0,08	0,18	0,7	4,9	490	SL/BL 32 x 40 R
40	20	5700	4 x 2,7	41,8	129,4	0,08	0,42	1,4	8,2	1380	SL/BL 40 x 20 R
40	40	5700	4 x 1,7	53,3	133,8	0,10	0,53	2,5	8,1	1330	SL/BL 40 x 40 R
50	50	5700	4 x 1,7	94,8	238,2	0,12	1,19	3,4	13,2	3560	SL/BL 50 x 50 R

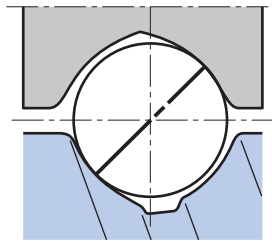

SL

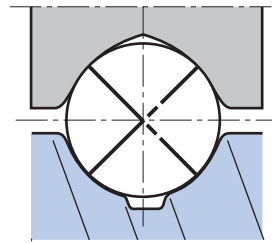

BL

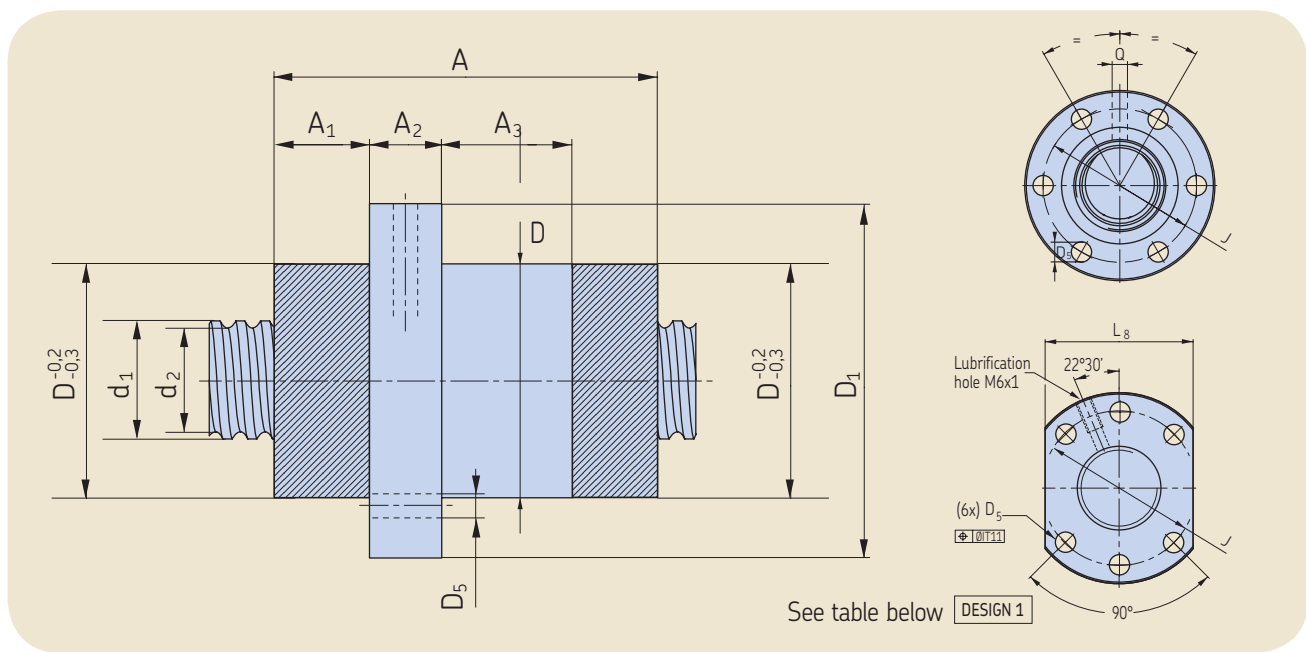

Designation	Screw shaft		Nut							Lubrication hole		
	d_2	d_1	D_{g9}	D_1	A_1	A	A_2	A_3	J_{js12}	L_8	D_5	Q
—	mm											
SL/BL 25 x 20 R	21,7	24,3	48	73	17,4	66,4	15	18	60		6 x 6.6	M6
SL/BL 25 x 25 R	21,5	24,4	48	73	18,6	77,9	15	27	60		6 x 6.6	M6
SL/BL 32 x 20 R	27,5	30,0	56	80	17,4	66,4	15	18	68		6 x 6.6	M6
SL/BL 32 x 32 R	28,4	31,1	56	80	13,0	80,3	15	41	68		6 x 6.6	M6
SLD/BLD 32 x 32 R	28,4	31,1	50 g6	80	13,0	80,3	15	41	65	62	6 x 9.0	M6 (Design 1)
SL/BL 32 x 40 R	26,9	29,6	53 g6	80	12,0	55,0	15	17	68		6 x 6.6	M6
SL/BL 40 x 20 R	35,2	37,7	63	95	17,8	86,8	15	38	78		6 x 9.0	M6
SL/BL 40 x 40 R	34,2	38,3	72	110	21,3	110,3	25	44	90		6 x 11	M8 x 1
SL/BL 50 x 50 R	43,5	49,1	85	125	25,5	134,0	25	60	105		6 x 11	M8 x 1

Designation: see page 49

Rotating nut

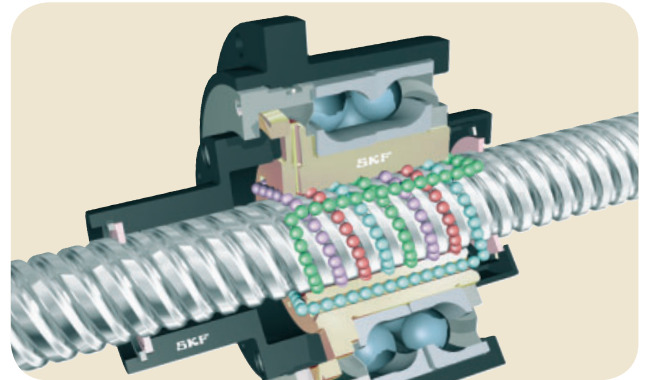
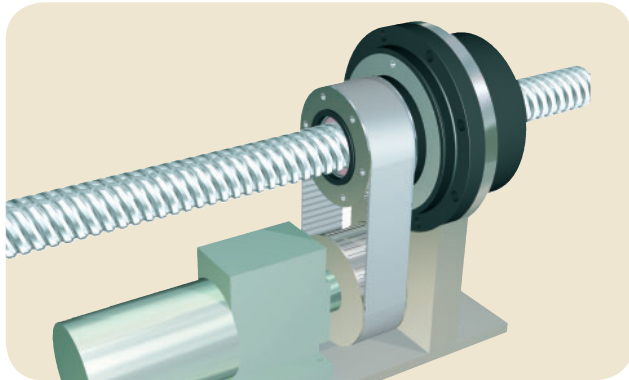

Concept

The nut rotates inside bearings and moves along the fixed long lead screw shaft.

The drive motor moves with the nut, so inertia & critical speed problems, associated with a long rotating shaft, are minimised.

Design details

- 72 series angular contact bearings are directly mounted on the nut.
- They are preloaded in “0” configuration in order to fully support the torque due to the belt tension.

- 2 Nilos seals protect these bearings against pollution and permit lubrication for life.
- Two versions available:
 - * Ball screw with axial play: SLT
 - * Ball screw with backlash elimination: BLT
- Two brush wipers are mounted in the standard configuration for better protection.
- Ball screw lubrication: through the nipple placed on the housing external diameter in the standard version, or as an option through the screw shaft.
- Ball nut greased with SKF LGMT2. Other lubricants possible on request.

Benefits

- Easy and simple to incorporate.
- Compact solution, ready to use.
- Fixed screw shaft: simplified mounting.
- Inertia considerably reduced: 3800 kgmm² instead of 6000 kgmm² for a screw shaft, 40x40 - 4.5 m stroke.
- Smaller, lighter, lower power motors.
- Higher linear speeds: up to 110 m/min.

Size	Ball screw capacities		Bearing axial capacities	
	Dynamic capacity C_a	Static capacity C_{0a}	Dynamic capacity C_a	Static capacity C_{0a}
	kN	kN	kN	kN
25x20	39,5	96,6	61,8	56,0
25x25	33,5	80,5	61,8	56,0
32x20	49,8	141,2	78,0	76,5
32x32	32,1	87,3	78,0	76,5
32x40	30,0	81,7	78,0	76,5
40x20	54,7	176,7	93,6	91,5
40x40	53,3	133,8	114,0	118,0
50x50	94,8	238,2	156,0	166,0

Rotating nut inertia

Size	Inertia Pulley support	Mass of rotating nut
	kgmm ²	kg
25x20	1012	4,5
25x25	1023	4,6
32x20	1935	7,2
32x32	1919	7,1
32x40	1949	7,1
40x20	3095	7,5
40x40	3784	8,4
50x50	11482	15,5

Rotating nut capacities

Size	Max. transmissible torque	Max. transmissible axial load
	Nm	kN
25x20	180	68,3
25x25	180	68,3
32x20	209	107,0
32x32	209	87,3
32x40	209	81,7
40x20	240	116,0
40x40	246	93,3
50x50	803	162,0

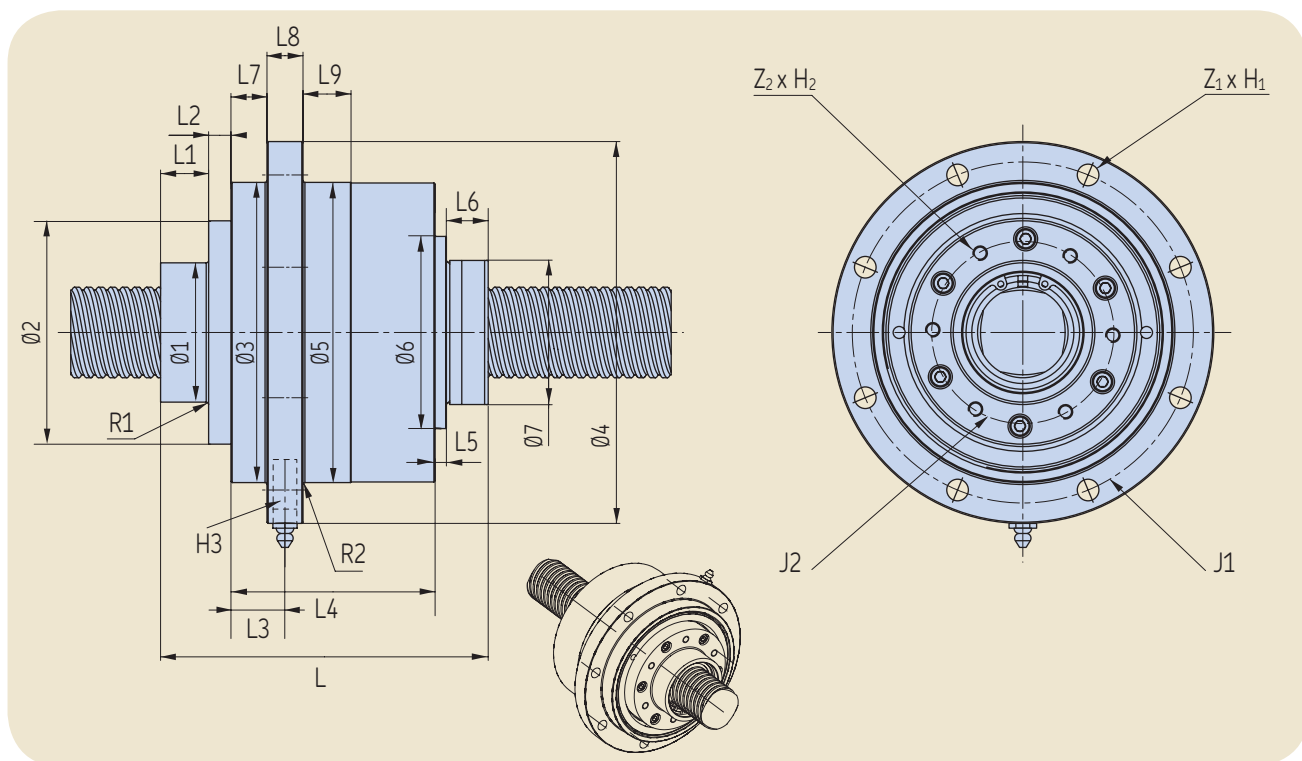

	Ø1	Ø2	Ø3	Ø4	Ø5	Ø6	Ø7	L	L1	L2	L3	L4	L5	L6	L7	L8	L9	R1	R2	J1	J2	Z1xH1	Z2xH2x	H3 useful depth				
Designation	h8		g6																			max		max		mm		
SLT/BLT 25x20	40	72,5	100,0	133	100	65	48	121,0	15	12,4	19,9	74	2,9	16,8	12,4	15	15	0,8	0,8	116	55	6xØ9	6xM6x20	M6x1				
SLT/BLT 25x25	40	72,5	100,0	133	100	65	48	126,2	15	12,4	19,9	74	2,9	21,9	12,4	15	15	0,8	0,8	116	55	6xØ9	6xM6x20	M6x1				
SLT/BLT 32x20	50	82,0	119,5	150	120	76	56	132,4	20	3,8	27,5	89	2,2	17,4	20,0	15	20	0,8	0,8	135	68	6xØ9	6xM6x20	M6x1				
SLT/BLT 32x32	50	82,0	119,5	150	120	76	50	126,8	20	3,8	27,5	89	2,2	11,8	20,0	15	20	0,8	0,8	135	68	6xØ9	6xM6x20	M6x1				
SLT/BLT 32x40	50	82,0	119,5	150	120	76	53	125,7	20	3,8	27,5	89	2,2	10,7	20,0	15	20	0,8	0,8	135	68	6xØ9	6xM6x20	M6x1				
SLT/BLT 40x20	58	93,0	125,0	159	125	80	63	136,4	20	9,3	22,5	85	4,7	17,4	15,0	15	20	0,8	0,8	142	75	8xØ9	6xM6x20	M8x1				
SLT/BLT 40x40	60	93,0	137,0	168	137	102	72	159,3	47	8,8	19,0	83	0	20,5	11,5	15	20	1,6	1,6	153	80	8xØ9	6xM6x20	M8x1				
SLT/BLT 50x50	70	120,0	170,0	210	170	110	85	163,3	20	15,5	25,4	100	4,5	23,5	15,7	20	25	1,6	1,6	190	106	8xØ11	6xM8x30	M8x1				

All tolerances js13 if not specified.



Shaft end combinations

In the order code, shaft end machining is defined by:

- one letter for $\varnothing < 16$ mm
- two letters for $\varnothing \geq 16$ mm

resulting from the combination of two machined ends (see designation page 49).

Machined ends are represented in details in page 37 for $\varnothing < 16$ mm and page 38 for $\varnothing \geq 16$ mm.

$\varnothing < 16$ mm		$\varnothing \geq 16$ mm	
Order code	Two machined ends	Order code	Two machined ends
A (without length indication)	cut only	AA (without length indication)	cut only
A (+ length)	cut + annealed		
B	1 + 2	BA	1A + 2A
F *	2 + 2	FA *	2A + 2A
G *	2 + 3	GA *	2A + 3A
H	2 + 4	HA	2A + 4A
J	2 + 5	JA	2A + 5A
M	3 + 5	MA	3A + 5A
S (+ length)	Ends to root diameter, any possible lengths	SA (+ length)	Ends to root diameter d_2 , any possible lengths.
		UA ■ (+ length)	End machined to diameter d_3 under induction hardening, any possible lengths.
K	Keyway	K	Keyway
Z	To customer's drawing	Z	To customer's drawing

* Attention ! This mounting requires the greatest precautions. Please contact us.

■ UA: end machined to diameter d_3 under induction hardening, any possible lengths.

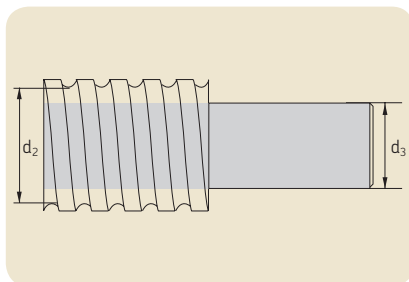

UA end machining

Dimensions	$\varnothing d_2$	$\varnothing d_3$
	mm	mm
16 x 5	12,7	9
20 x 5	16,7	14
25 x 5	21,7	19
25 x 10	20,5	18
25 x 20	21,7	19
25 x 25	21,5	18
32 x 5	28,7	26
32 x 10 DIN	27,8	25
32 x 10	26,0	23
32 x 20	27,5	24
32 x 32	28,4	26
32 x 40	26,9	24
40 x 5	36,7	34
40 x 10	34,0	31
40 x 20	35,2	32
40 x 40	34,2	31
50 x 10	44,0	41
50 x 50	43,5	40
63 x 10	57,0	54

Standard end machining for nominal diameter < 16 mm

Special ends are machined to customers drawing on request.

For SD - SH

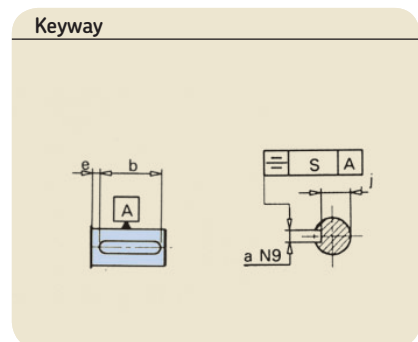
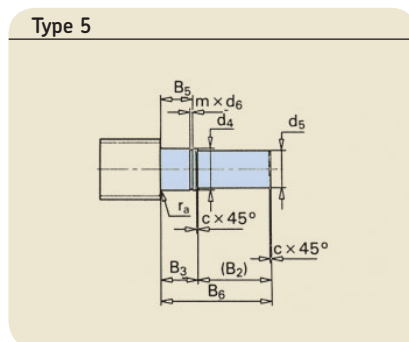
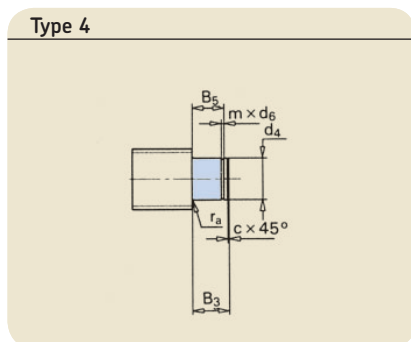
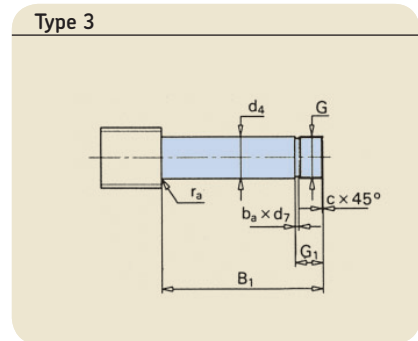
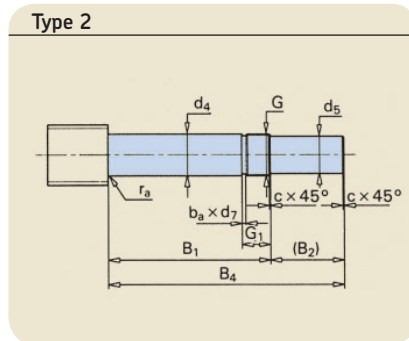
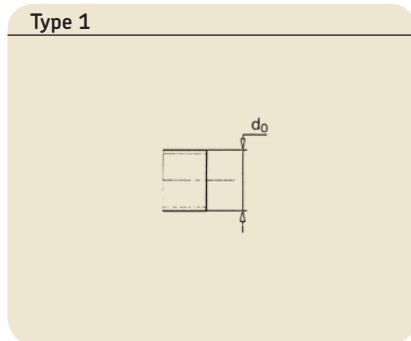

d_0	d_5	d_4	B_1	B_2	B_3	B_4	B_5	B_6	G	G_1	m	d_6	c	b_a	d_7	r_a	a	b	e	j	S	Keyway
	h7	js7	js12		js12	js12	H11	js12	6g		+0,140 0	h11/h12			h11	maxi	N9	+0,5 0				DIN 6885
6	3	4	22	10	7	32	5,4	17	M4 x 0,7	7,0	0,5	3,8	0,5	1,2	2,9							
8	4	5	24	12	7	36	5,6	19	M5 x 0,8	7,2	0,7	4,8	0,5	1,2	3,7	0,3						
10	5	6	26	12	9	38	6,7	21	M6 x 1	7,5	0,8	5,7	0,5	1,5	4,5	0,3						
12/12,7	6	8	38	12	10	50	7,8	22	M8 x 1	12,5	0,9	7,6	0,5	1,5	6,5	0,3	2	8	3	4,8	0,1	A2 x 2 x 8
14	8	10	40	16	12	56	9,0	28	M10 x 1,5	13,3	1,1	9,6	0,5	2,3	7,8	0,3	2	10	3	6,8	0,1	A2 x 2 x 10

Standard end machining for nominal diameter ≥ 16 mm

Standard shaft ends for ball screws, nominal diameter ≥ 16 mm, have been developed to suit the SKF thrust bearings FLBU, PLBU and BUF.

These standard ends are the same for all screw types. However, for the "SL/BL" long lead screw, an additional shoulder, part of the threaded length, will be machined to protect the wiper and nut thread during assembly (both sides).

Apart from this, the end itself is the same for all screw types.

End bearing \Rightarrow Machined end type
 FLBU 2A or 3A
 PLBU 2A or 3A
 BUF 4A or 5A

For SD/BD - SX/BX - SN/BN/PN - SND/BND/PND

Size d_0	d_5	d_4	d_{10}	d_{11}	d_{12}	B_1	B_2	B_3	B_4	B_5	B_6	B_7	B_9	d_8	G	G_1	m	d_6	c	c_1	b_a	d_7	r_a	Keyway to DIN 6885 a^{N9} xl xb		
	h7	h6	h6	h7	js12	js12	js12	H11	js12		6g	+ 0,14 + 0	h11	h12							h11			fixed end (type 2A)	fixed end (type 5A)	
16	8	10	/	10	8	53	16	13	69	10	29	2	0	12.5	M10x0.75	17	1.1	9.6	0.5	0.5	1.2	8.8	0.4	A2x2x12	A2x2x12	
20	10	12	/	10	8	58	17	13	75	10	29	2	0	14.5	M12x1	18	1.1	9.6	0.5	0.5	1.5	10.5	0.8 0.4 _{1/}	A3x3x12	A2x2x12	
25	15	17	/	17	15	66	30	16	96	13	46	4.5	0	20	M17x1	22	1.1	16.2	0.5	0.5	1.5	15.5	0.8 0.4 _{1/}	A5x5x25	A5x5x25	
32	17	20	/	17	15	69	30	16	99	13	46	4.5	0	21.7	M20x1	22	1.1	16.2	0.5	0.5	1.5	18.5	1.2 0.8 _{1/}	A5x5x25	A5x5x25	
40	25	30	/	30	25	76	45	22	121	17.5	67	4.5	0	33.5	M30x1.5	25	1.6	28.6	1	0.5	2.3	27.8	0.8 0.4 _{1/}	A8x7x40	A8x7x40	
50	30	35	/	30	25	84	55	22	139	17.5	67	4.5	0	35.2	M35x1.5	27	1.6	28.6	1	0.5	2.3	32.8	1.2 0.8 _{1/}	A8x7x45	A8x7x40	
63	40	50	/	45	40	114	65	28	179	20.75	93	3	0	54	M50x1.5	32	1.85	42.5	1.5	1	2.3	47.8	1.2 0.8 _{1/}	A12x8x50	A12x8x50	

For SL/BL only

Size d_0	d_5	d_4	d_{10}	d_{11}	d_{12}	B_1	B_2	B_3	B_4	B_5	B_6	B_7	B_9	d_8	G	G_1	m	d_6	c	c_1	b_a	d_7	r_a	Keyway to DIN 6885 a^{N9} xl xb		
	h7	h6	h6	h7	js12	js12	js12	H11	js12		6g	+ 0,14 + 0	h11	h12							h11			fixed end (type 2A)	fixed end (type 5A)	
25 x 20	15	17	/	17	15	66	30	16	96	13	46	4.5	0	21.7	M17 x 1	22	1.1	16.2	0.5	0.5	1.5	15.5	0.8	A5x5x25	A5x5x25	
25 x 25	15	17	/	17	15	66	30	16	96	13	46	4.5	0	21.5	M17 x 1	22	1.1	16.2	0.5	0.5	1.5	15.5	0.8	A5x5x25	A5x5x25	
32 x 20	17	20	21.5	17	15	69	30	16	99	13	46	4.5	2	27.4	M20 x 1	22	1.1	16.2	0.5	0.5	1.5	18.5	1.2 0.8 _{1/}	A5x5x25	A5x5x25	
32 x 32	17	20	21.5	17	15	69	30	16	99	13	46	4.5	2	28.4	M20 x 1	22	1.1	16.2	0.5	0.5	1.5	18.5	1.2 0.8 _{1/}	A5x5x25	A5x5x25	
32 x 40	17	20	21.5	17	15	76	30	16	99	13	46	4.5	2	26.9	M20 x 1	22	1.1	28.6	0.5	0.5	1.5	18.5	1.2 0.8 _{1/}	A5x5x25	A5x5x25	
40 x 20	25	30	/	30	25	76	45	22	121	17.5	67	6.5	0	35.2	M30 x 1.5	25	1.6	28.6	1	0.5	2.3	27.8	0.8	A8x7x40	A8x7x40	
40 x 40	25	30	/	30	25	76	45	22	121	17.5	67	6.5	0	35.0	M30 x 1.5	25	1.6	28.6	1	0.5	2.3	27.8	0.8	A8x7x40	A8x7x40	
50 x 50	30	35	37	30	25	84	55	22	139	17.5	67	9	3	43.4	M35 x 1.5	27	1.6	28.6	1	0.5	2.3	32.8	1.2 0.8 _{1/}	A8x7x45	A8x7x40	

1 / for end types 4A or 5A

Standard machined ends

Threaded length = total length - end length

(■) : end length

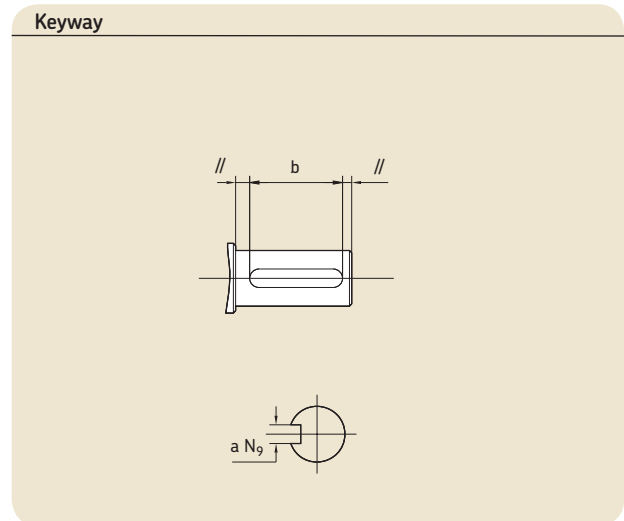
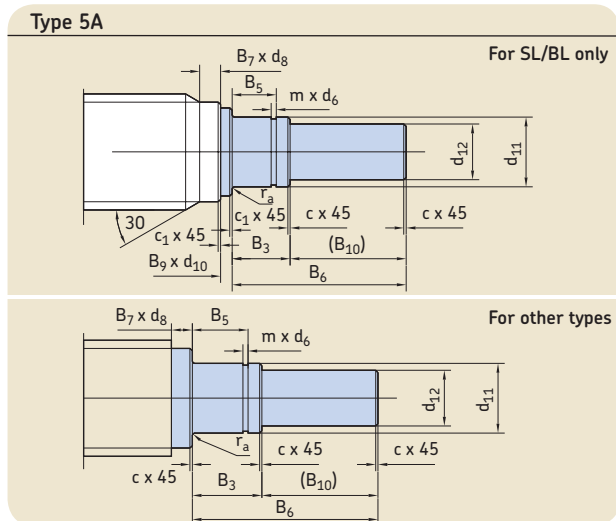
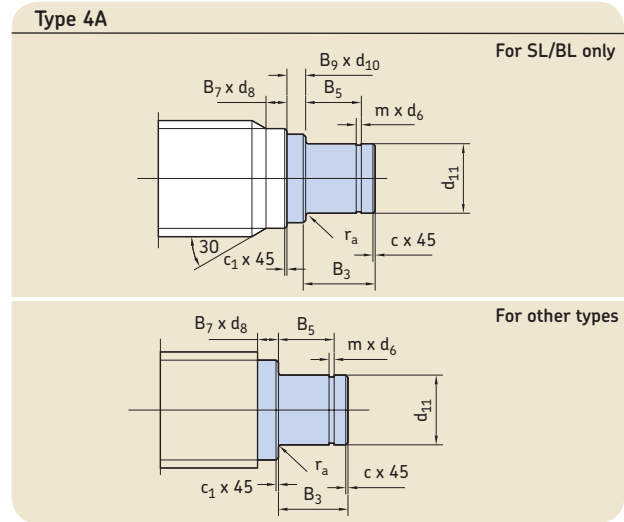
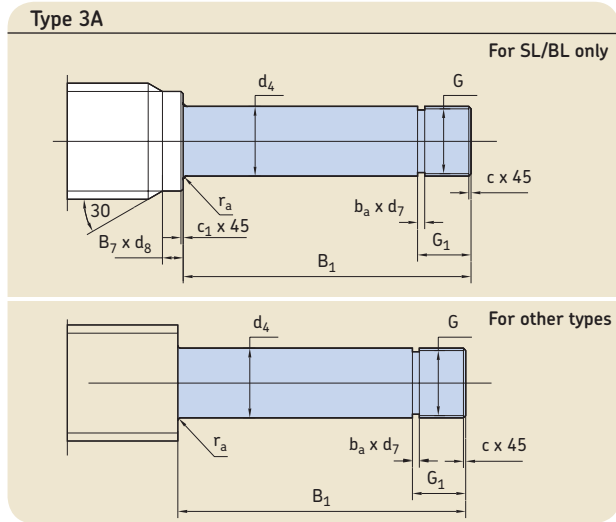
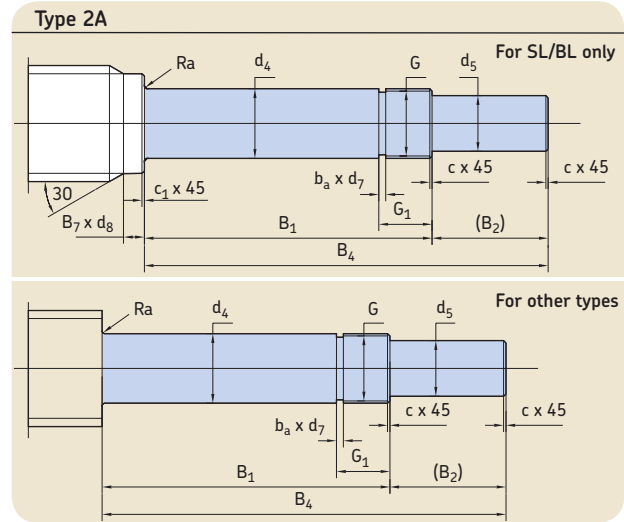
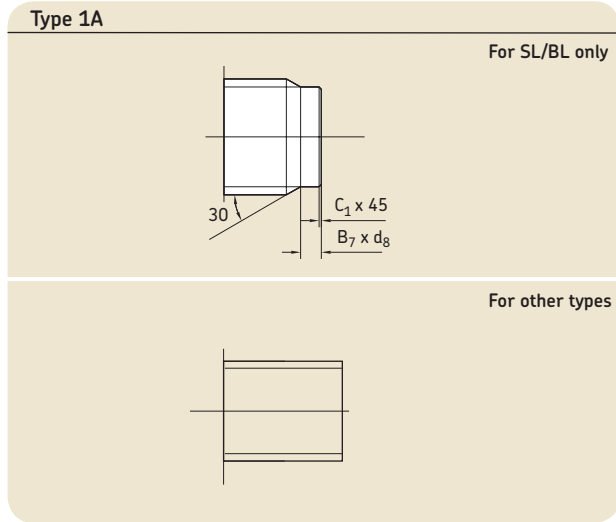

End bearings

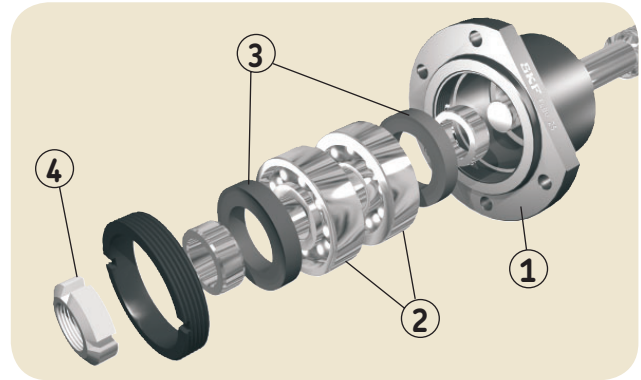
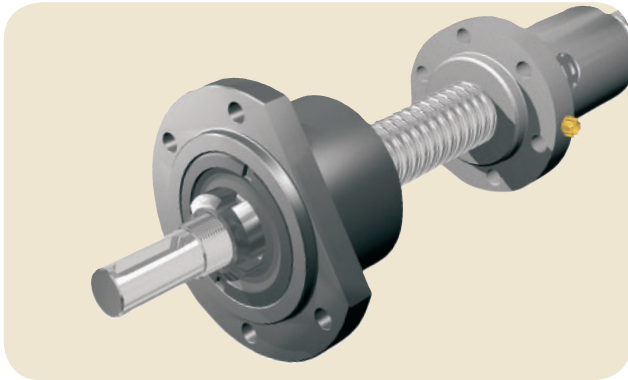

Axially locating flanged housing with SKF angular contact ball bearings (back to back arrangement).

The “FLBU” flanged bearing unit consists of:

- precision housing, made of burnished steel ①
- two SKF preloaded angular contact ball bearings, 72 or 73 series ②
- two garter seals ③
- locknut, self-locking Nylstop type or, on demand, high precision KMT ④

The “FLBU” flanged thrust bearing unit provides the following benefits:

- lubrication for life.
- very easy mounting (matched bearings, hand mounting on the shaft end) as well as easy disassembly with the optional high precision KMT nut.

In standard version, the “FLBU” thrust bearing unit is assembled according to drawing page 41. If you require a different assembly, please indicate it when ordering.

Size d ₀	Flanged bearing unit designation	Angular contact ball bearing (40°)			Lock nut						
		C _a (kN)	C _{oa} (kN)	SKF Bearing designation	Self locking nut		High precision nut 3/				
					Designation	Hook spanner	Designation	Hook spanner	Tightening torque (Nm)	Grub screws Size	Max. tightening torque (Nm)
16	FLBU 16	12.2	12.8	7200 BECB 1/	CN 70-10	HN 1	KMT 0	HN 2/3	4	M 5	4.5
20	FLBU 20	13.3	14.7	7201 BEGA 2/	CN 70-12	HN 1	KMT 1	HN 3	8	M 5	4.5
25	FLBU 25	27.9	31.9	7303 BEGA 2/	CN 70-17	HN 3	KMT 3	HN 4	15	M 6	8.0
32	FLBU 32	24.6	31.9	7204 BEGA 2/	CN 70-20	HN 4	KMT 4	HN 5	18	M 6	8.0
40	FLBU 40	41.9	59.6	7206 BEGA 2/	CN 70-30	HN 6	KMT 6	HN 6	32	M 6	8.0
50	FLBU 50	54.5	79.8	7207 BEGA 2/	CN 70-35	HN 7	KMT 7	HN 7	40	M 6	8.0
63	FLBU 63	128.0	196.1	7310 BEGA 2/	CN 70-50	HN 10	KMT 10	HN 10/11	60	M 8	18.0

1/ No backlash elimination • 2/ Light preload • 3/ Optional

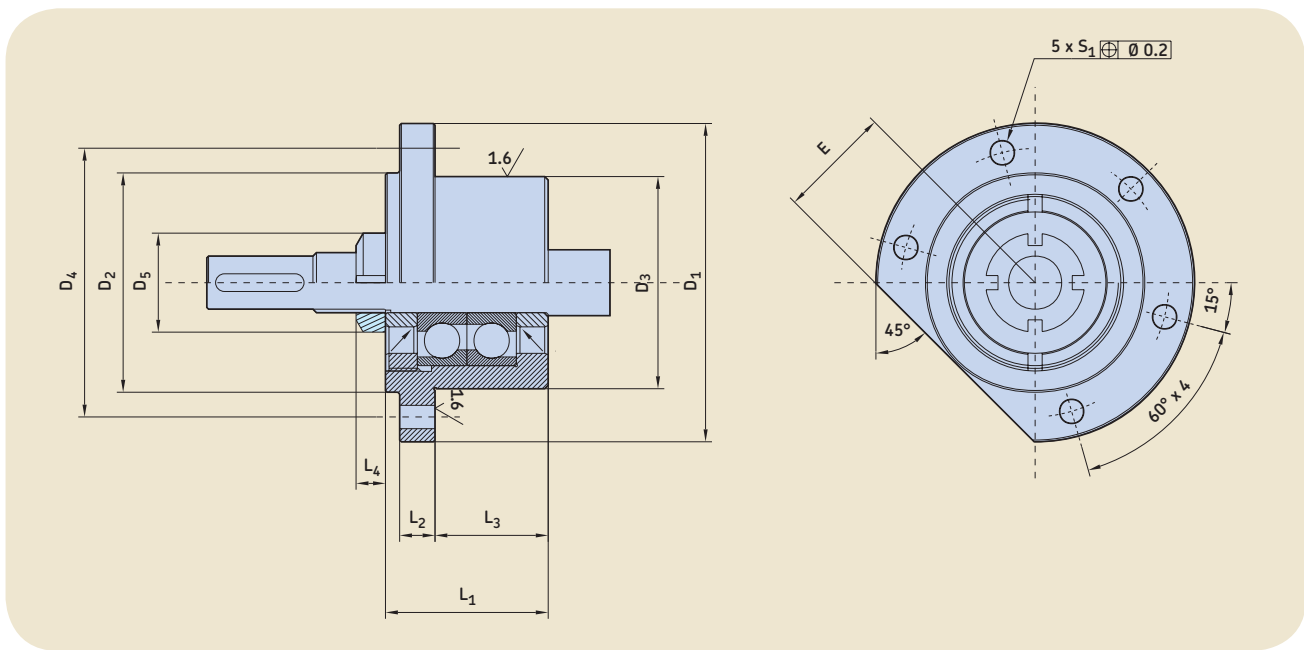

Size d ₀	Dimensions (mm)													
	L ₁	L ₂	L ₃	L ₄		D ₁	D ₂	D ₃ h7	D ₄	D ₅		S ₁ H13	Fixing screws	E
				Self locking nut	High precision nut 1/					Self locking nut	High precision nut 1/			
16	37	10	22	7.0	14	76	50	47	63	18	28	6.6	M6 x 30	26
20	42	10	25	7.5	14	76	50	47	63	21	30	6.6	M6 x 30	27
25	46	10	32	8.3	18	90	62	60	76	28	37	6.6	M6 x 30	32
32	49	13	32	8.3	18	90	59	60	74	32	40	9.0	M8 x 40	32
40	53	16	32	11.0	20	120	80	80	100	44	49	11.0	M10 x 45	44
50	59	20	32	11.0	22	130	89	90	110	50	54	13.0	M12 x 60	49
63	85	25	43.5	11.7	25	165	124	124	146	68	75	13.0	M12 x 60	64

1/ Optional

End bearings

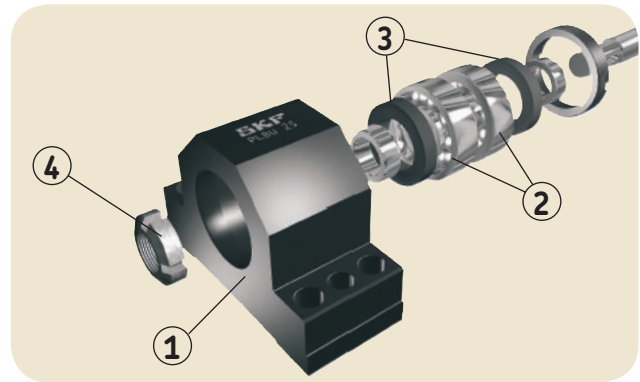
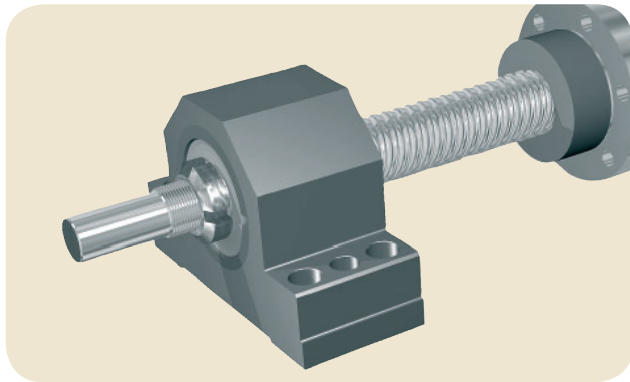

Fixed plummer housing with SKF angular contact ball bearings (back to back arrangement)

The “PLBU” plummer bearing unit consists of:

- precision housing, made of burnished steel, with precision reference edges on both sides ①
- two SKF preloaded angular contact ball bearings, 72 or 73 series ②
- two garter seals ③
- locknut, self-locking Nylstop type or, on demand, high precision KMT ④

The “PLBU” plummer bearing unit provides the following benefits:

- lubrication for life.
- very easy mounting (matched bearing, hand mounting on the shaft ends) as well as easy disassembly with the optional high precision KMT nut.
- good rigidity guaranteed by foot mounting with dowel pins.

Size d ₀	Flanged bearing unit designation	Angular contact ball bearing (40°)			Lock nut						
		Basic load rating (axial) C _a (kN)	C _{oa} (kN)	SKF Bearing designation	Self locking nut		High precision nut 3/				
					Designation	Hook spanner	Designation	Hook spanner	Tightening torque (Nm)	Grub screws Size	Max. tightening torque (Nm)
16	PLBU 16	12.2	12.8	7200 BECB 1/	CN 70-10	HN 1	KMT 0	HN 2/3	4	M 5	4.5
20	PLBU 20	13.3	14.7	7201 BEGA 2/	CN 70-12	HN 1	KMT 1	HN 3	8	M 5	4.5
25	PLBU 25	27.9	31.9	7303 BEGA 2/	CN 70-17	HN 3	KMT 3	HN 4	15	M 6	8.0
32	PLBU 32	24.6	31.9	7204 BEGA 2/	CN 70-20	HN 4	KMT 4	HN 5	18	M 6	8.0
40	PLBU 40	41.9	59.6	7206 BEGA 2/	CN 70-30	HN 6	KMT 6	HN 6	32	M 6	8.0
50	PLBU 50	54.5	79.8	7207 BEGA 2/	CN 70-35	HN 7	KMT 7	HN 7	40	M 6	8.0
63	PLBU 63	128.0	196.1	7310 BEGA 2/	CN 70-50	HN 10	KMT 10	HN 10/11	60	M 8	18.0

1/ No backlash elimination • 2/ Light preload • 3/ Optional

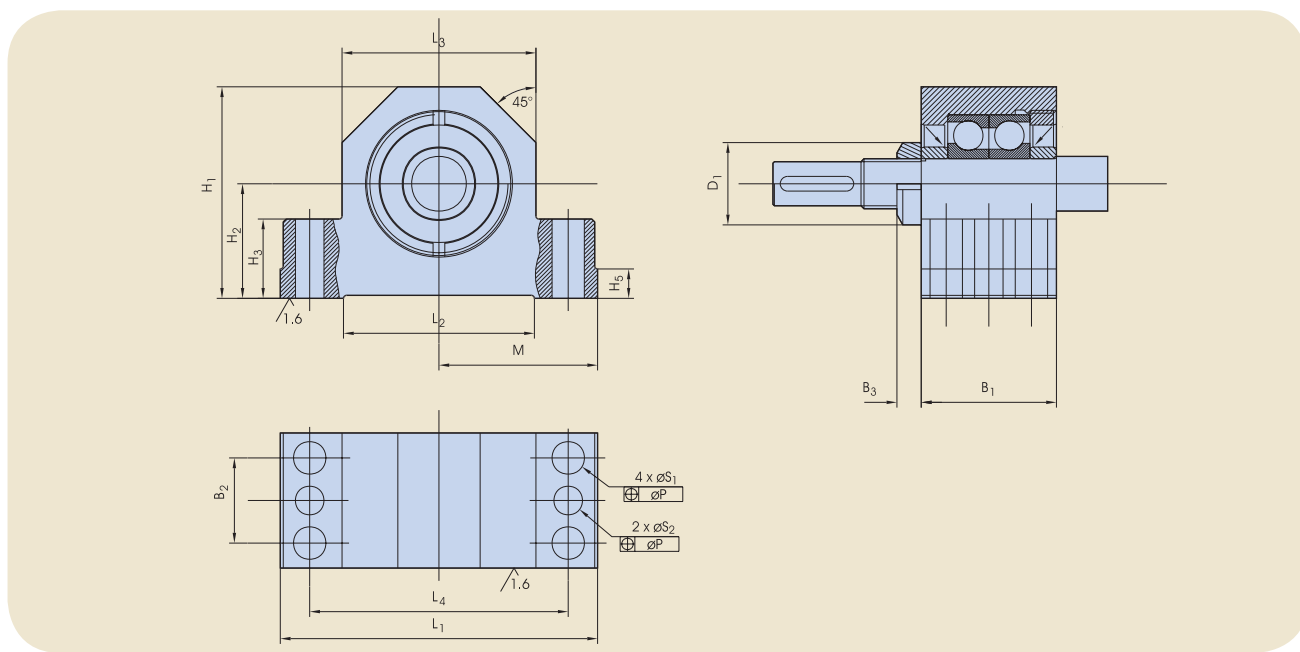

Dimensions (mm)																					
Size	L ₁	L ₂	L ₃	L ₄	M	B ₁	B ₂	B ₃		H ₁	H ₂	H ₃	H ₄	H ₅	S ₁	P	Fixing screws	S ₂	D ₁		Tapered pin
d ₀					js8			Self locking nut	High precision nut 1/		js8							H12	Self locking nut	High precision nut 1/	(hardened) or straight pin (DIN6325)

16	86	52	52	68	43	37	23	7.0	14	58	32	22	15	8	9	0.15	M8 x 35	7.7	18	28	8 x 40
20	94	52	60	77	47	42	25	7.5	14	64	34	22	17	8	9	0.15	M8 x 35	7.7	21	30	8 x 40
25	108	65	66	88	54	46	29	8.3	18	72	39	27	19	10	11	0.20	M10 x 40	9.7	28	37	10 x 50
32	112	65	70	92	56	49	29	8.3	18	77	45	27	20	10	11	0.20	M10 x 40	9.7	32	40	10 x 50
40	126	82	80	105	63	53	32	11.0	20	98	58	32	23	12	13	0.20	M12 x 50	9.7	44	49	10 x 50
50	144	80	92	118	72	59	35	11.0	22	112	65	38	25	12	13	0.20	M12 x 55	9.7	50	54	10 x 55
63	190	110	130	160	95	85	40	11.7	25	130	65	49	35	15	13	0.20	M12 x 65	9.7	68	75	10 x 65

1/ Optional

End bearings

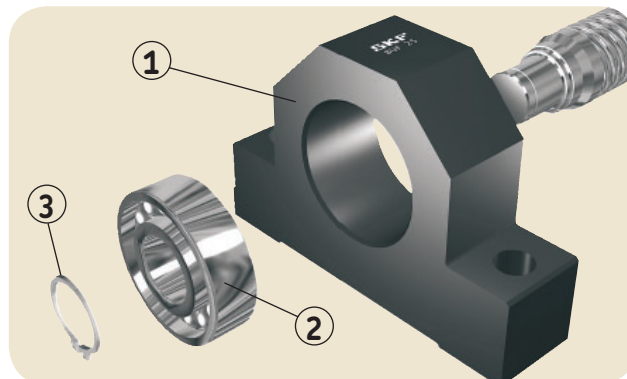
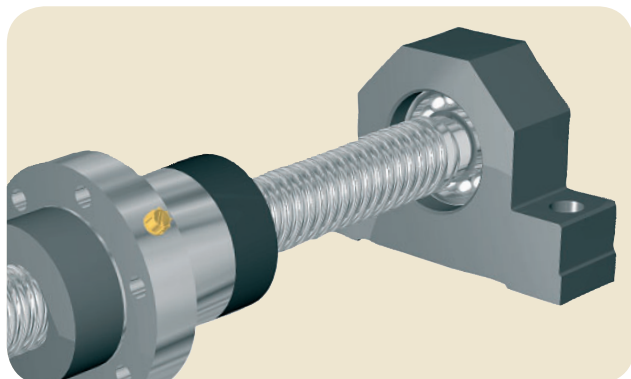

Axially free plummer housing with SKF deep-groove ball bearing

The “BUF” plummer bearing unit consists of:

- bearing housing made of burnished steel, with one reference side ①
- grease-tight deep-groove SKF ball bearing, greased for life, type 62... 2RS1 ②
- retaining ring ③

In standard version, the “BUF” thrust bearing unit is assembled according to drawing page 45. If you require a different assembly, please indicate it when ordering.

Size d_0	Plummer bearing unit designation (free)	Deep-groove ball bearing			Dimensions (mm)			Retaining ring (DIN 471)
		Basic load rating (radial) C (kN)	C_0 (kN)	SKF Bearing designation	d	D	B	
16	BUF 16	5.07	2.36	6200.2RS1	10	30	9	10x1
20	BUF 20	5.07	2.36	6200.2RS1	10	30	9	10x1
25	BUF 25	9.56	4.75	6203.2RS1	17	40	12	17x1
32	BUF 32	9.56	4.75	6203.2RS1	17	40	12	17x1
40	BUF 40	19.5	11.2	6206.2RS1	30	62	16	30x1.5
50	BUF 50	19.5	11.2	6206.2RS1	30	62	16	30x1.5
63	BUF 63	33.2	21.6	6209.2RS1	45	85	19	45x1.75

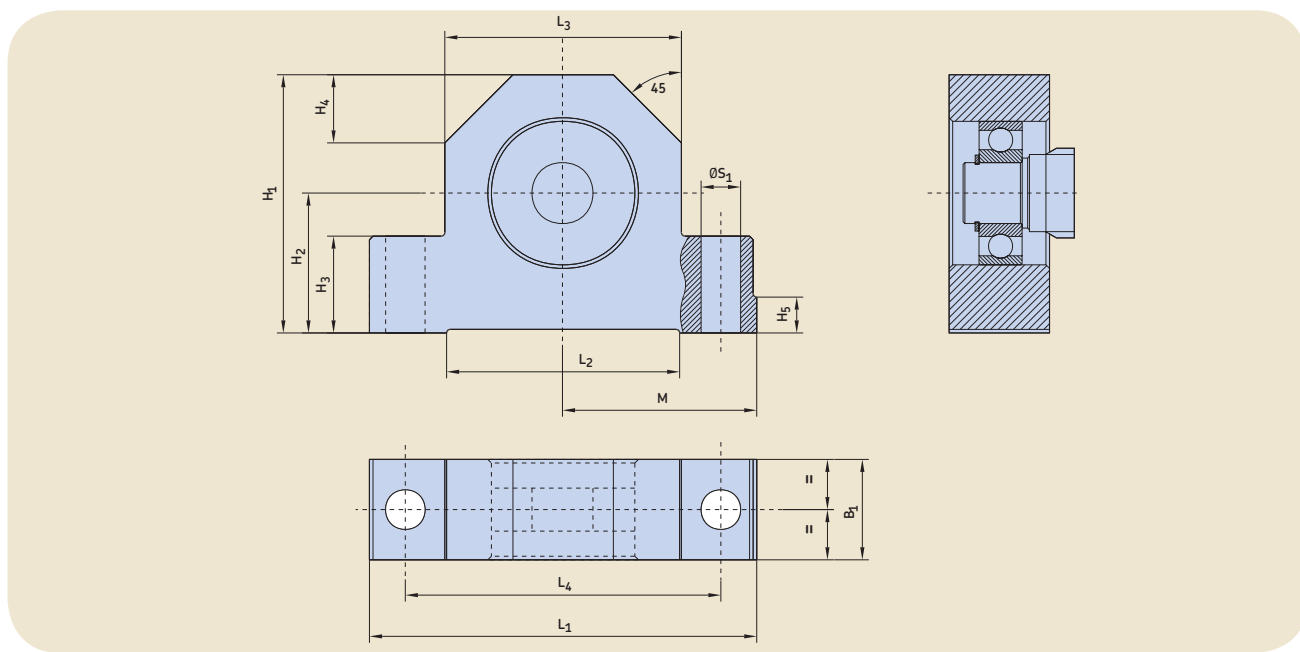

Dimensions (mm)													
Size d_0	L_1	L_2	L_3	L_4	M js8	B_1	H_1	H_2 js8	H_3	H_4	H_5	S_1 H12	Fixing screws
16	86	52	52	68	43	24	58	32	22	15	8	9	M8 x 35
20	94	52	60	77	47	26	64	34	22	17	8	9	M8 x 35
25	108	65	66	88	54	28	72	39	27	19	10	11	M10 x 40
32	112	65	70	92	56	34	77	45	27	20	10	11	M10 x 40
40	126	82	80	105	63	38	98	58	32	23	12	13	M12 x 50
50	144	80	92	118	72	39	112	65	38	25	12	13	M12 x 55
63	190	110	130	160	95	38	130	65	49	35	15	13	M12 x 65

Calculation formulas

1. Dynamic load rating (N) and Basic life rating

$$L_{10} = \left(\frac{C_a}{F_m} \right)^3 \text{ or } C_{\text{req}} = F_m (L_{10})^{1/3}$$

L_{10} = life (million of revolutions)
 C_a = basic dynamic load rating
 C_{req} = required dynamic load rating
 F_m = cubic mean load (N)

2. Cubic mean load (N)

$$F_m = \frac{(F_1^3 L_1 + F_2^3 L_2 + F_3^3 L_3 + \dots)^{1/3}}{(L_1 + L_2 + L_3 + \dots)^{1/3}}$$

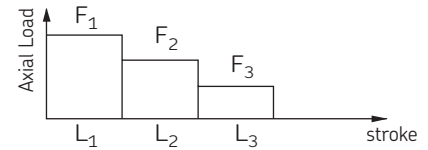

$$F_m = \frac{F_{\text{min}} + 2F_{\text{max}}}{3}$$

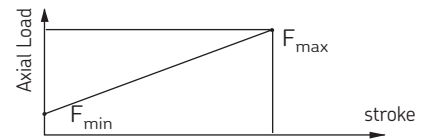

3. Critical speed of screw shaft (no safety factor) (rpm)
 (a factor of 0,8 is generally recommended)

$$n_{\text{cr}} = 490 \cdot 10^5 \cdot \frac{f_1 d_2}{l^2}$$

d_2 = root diameter (mm)
 l = free length, or distance between the two support bearings (see page 6)
 f_1 = 0,9 ●●— fixed, free
 3,8 ●●—● fixed, supported
 5,6 ●●—●● fixed, fixed

4. Speed limit of the mechanism (maxi speed applied through very short periods)

For instance :
 $n \times d_0 < 50\,000$
 with recirculation by tubes/inserts (SH-SD/BD-SX/BX-SN/BN/PN-SND/BND/PND)
 $n \times d_0 < 90\,000$
 with recirculation through flange (SL/BL-SLD/BLD)
 if $> 50\,000/90\,000$, consult SKF

n = revolutions per minute
 d_0 = screw shaft nominal diameter

5. Buckling strength (with a safety factor: 3) (N)

$$F_c = \frac{34000 \cdot f_3 \cdot d_2^4}{l^2}$$

d_2 = root diameter (mm)
 l = free length, or distance between the two support bearings
 f_3 = mounting correction factor
 0,25 ●●— fixed, free
 1 ●—● supported, supported
 2 ●●—● fixed, supported
 4 ●●—●● fixed, fixed

Calculation formulas

6. Theoretical efficiency

- direct (η)

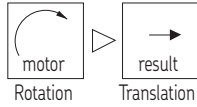

$$\eta = \frac{1}{1 + \frac{\pi \cdot d_0}{P_h} \mu}$$

μ = 0,0065 for SH
 μ = 0,006 for SD, SX, SL, SN, SND, BD, BX, BN, BL, PN, PND

d_0 = nominal diameter of screw shaft

P_h = lead (mm)

- indirect (η')

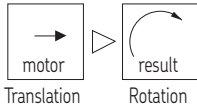

$$\eta' = 2 - \frac{1}{\eta}$$

7. Practical efficiency (η_p)

$$\eta_p = \eta \cdot 0,9$$

The value 0,9 used is an average value between the practical efficiency of a new screw and that of a properly run in screw. It should be used for industrial applications in all normal working conditions. For extreme cases, call us.

8. Input torque in a steady state (Nm)

$$T = \frac{F \cdot P_h}{2000 \cdot \pi \cdot \eta_p}$$

F = maximum load of the cycle (N)

P_h = lead (mm)

η_p = practical efficiency

9. Power required in a steady state (W)

$$P = \frac{F \cdot n \cdot P_h}{60000 \cdot \eta_p}$$

n = revolutions per minute

10. Preload torque (Nm)

$$T_{pr} = \frac{F_{pr} \cdot P_h}{1000 \cdot \pi} \left(\frac{1}{\eta_p} - 1 \right)$$

F_{pr} = preload (N)

Calculation formulas

11. Restraining torque
(Nm)
(considering system backdriving)

$$T_B = \frac{F \cdot P_h \cdot \eta'}{2000 \cdot \pi}$$

F = load (N)
For safety, we can use the theoretical indirect efficiency
 η' = indirect efficiency

12. Nominal motor torque when accelerating
(Nm)

For a horizontal screw

$$T_t = T_f + T_{pr} + \frac{P_h [F + m_L \cdot \mu_f \cdot g]}{2000 \cdot \pi \cdot \eta_p} + \dot{\omega} \Sigma I$$

For a vertical screw

$$T_t = T_f + T_{pr} + \frac{P_h [F + m_L \cdot g]}{2000 \cdot \pi \cdot \eta_p} + \dot{\omega} \Sigma I$$

T_f = torque from friction in support bearings, motors, seals, etc... (Nm)
 T_{pr} = preload torque
 μ_f = coefficient of friction
 η_p = real direct efficiency
 $\dot{\omega}$ = angular acceleration (rad/s²)
 m_L = mass of the load (kg)
g = acceleration of gravity (9,8 m/s²)
 $\Sigma I = I_M + I_L + I_S \cdot l \cdot 10^{-9}$

13. Nominal braking torque when decelerating
(Nm)

For a horizontal screw

$$T_t = T_f + T_{pr} + \frac{P_h \cdot \eta' [F + m_L \cdot \mu_f \cdot g]}{2000 \cdot \pi} + \dot{\omega} \Sigma I$$

For a vertical screw

$$T_t = T_f + T_{pr} + \frac{P_h \cdot \eta' [F + m_L \cdot g]}{2000 \cdot \pi} + \dot{\omega} \Sigma I$$

$I_L = m_L \left(\frac{P_h}{2\pi} \right)^2 10^{-6}$
 η' = theoretical indirect efficiency
 I_M = inertia of motor (kgm²)
 I_S = inertia of screw shaft per metre (kgmm²/m)
l = length of screw shaft (mm)

For additional information, please contact SKF

Designation

SN 32 x 5R 330/445 G7 L - HA + K **/** WPR

Nut type

- SD = Miniature screw, axial play, internal recirculation nut
- SDS = Miniature screw, axial play, stainless steel
- BD = Miniature screw, backlash elimination by oversize balls
- BDS = Miniature screw, backlash elimination, stainless steel
- SH = Miniature screw, axial play, recirculation by integrated tube
- SHS = Miniature screw, axial play, stainless steel
- SX = Universal screw, axial play
- BX = Universal screw, backlash elimination by oversize balls
- SN = Precision screw, axial play
- BN = Precision screw, backlash elimination by oversize balls
- SND = Precision screw, axial play, DIN nut
- BND = Precision screw, backlash elimination by oversize balls, DIN nut
- PN = Precision screw with optimal rigidity
- PND = Precision screw with optimal rigidity, DIN nut
- SL = Long lead screw, axial play
- SLD = Long lead screw, axial play, DIN nut
- BL = Long lead screw, backlash elimination by oversize balls
- BLD = Long lead screw, backlash elimination by oversize balls, DIN nut
- SLT = Rotating nut with axial play
- BLT = Rotating nut with backlash elimination

Nominal diameter x Lead

Hand

R = Right L = Left (on request)

Threaded length / Total length, mm

Lead precision: G9, G7, G5

Nut orientation

Threaded side or flange of nut towards shorter (S) or longer (L) machined end of shaft. In case of same end machining : (-)

Machined end combination

See page 36

Required lengths for: AA - SA (both side)

See page 36

WPR: with wipers • NOWPR: without • RING: safety ring (for SH-SD only)

REDPLAY :

Reduced axial play

The robust screws for long life in tough conditions.

\emptyset = 8 to 210 mm

Ph = 4 to 42 mm

- * high load carrying capacity
- * ability to survive occasional blows and shock loads
- * highly reliable, even in hostile surroundings and at high rotational speed.

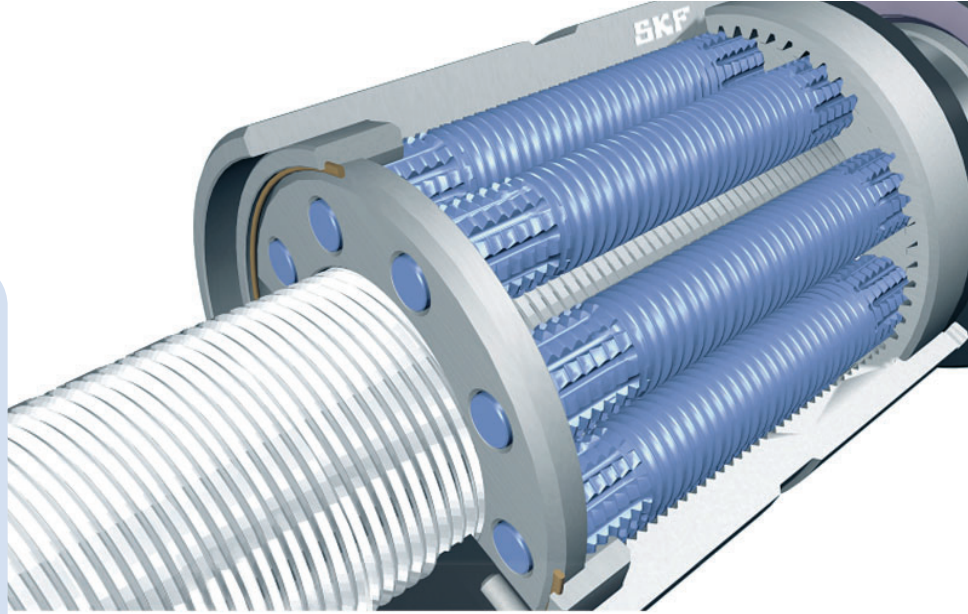

Planetary roller screws

Recirculating roller screws

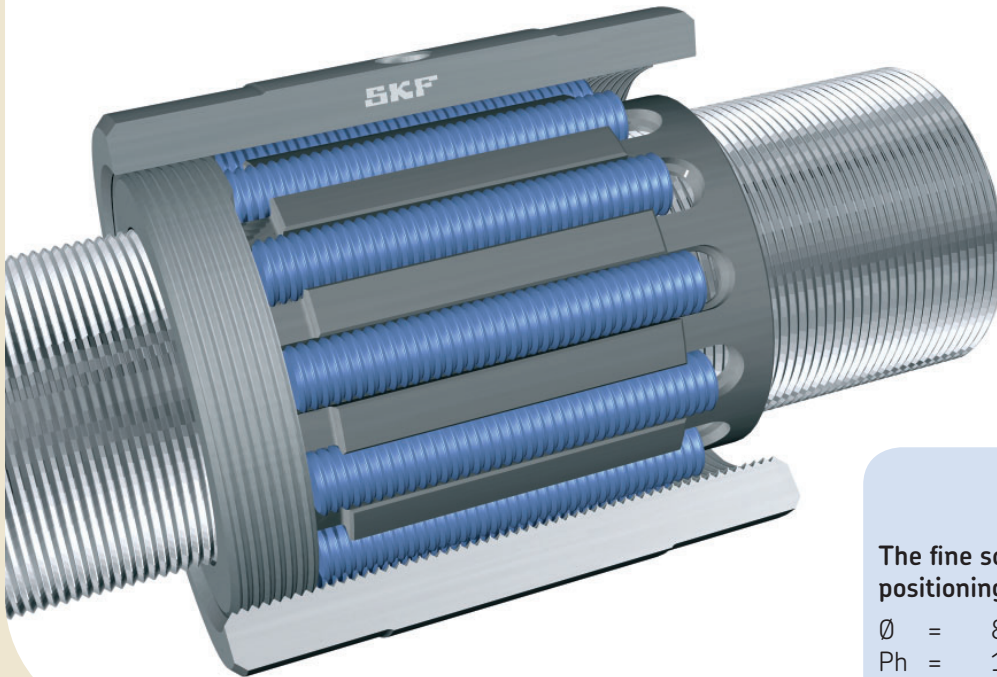

The fine screws for ultimate positioning accuracy.

\emptyset = 8 to 125 mm

Ph = 1 to 5 mm

- * fine resolution
- * high rigidity

Electro-mechanical cylinders

They are designed for long life, high acceleration and high force applications. The cylinders use brushless servomotor technology, with an in-line direct drive as standard.

SKF high performance electro-mechanical cylinders using planetary roller screws are expanding the limits of linear actuators.

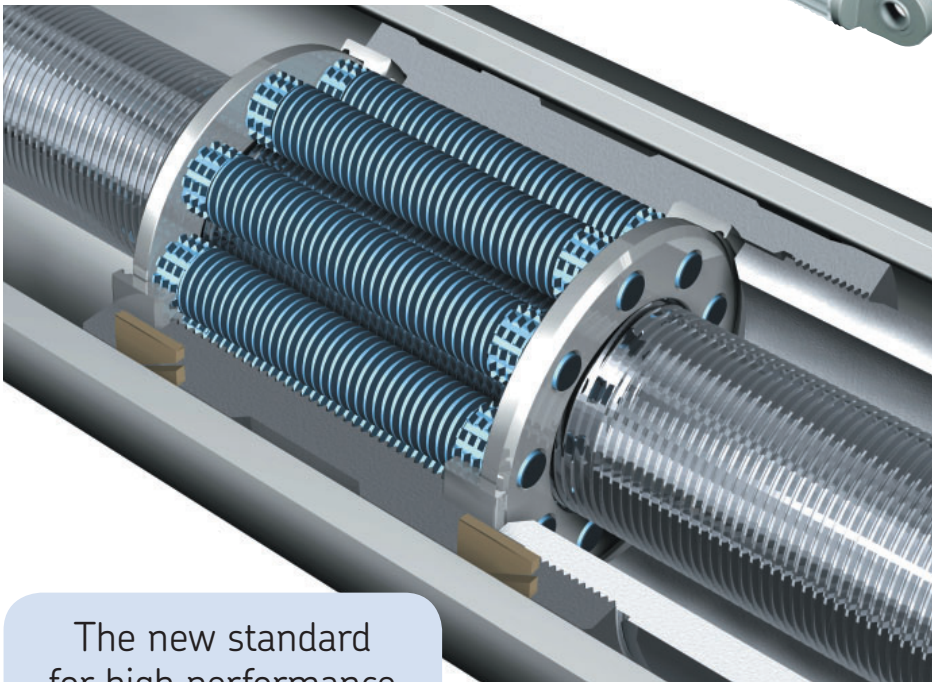

The high performance Electro-Mechanical cylinders consist of an SKF planetary roller screw directly driven through a coupling by a brushless motor.

The roller screw converts rotary motion into linear movement.

The new standard for high performance motion

Compact Electro-Mechanical cylinders (CEMC) are designed to deliver the combination of a dynamic flexible actuation packaged with powerful performance.

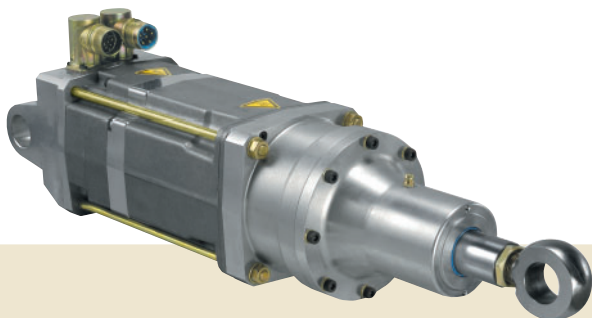

Cylinders for heavy loads

High loads and heavy working cycles: long life in adverse environments such as in steel industry.

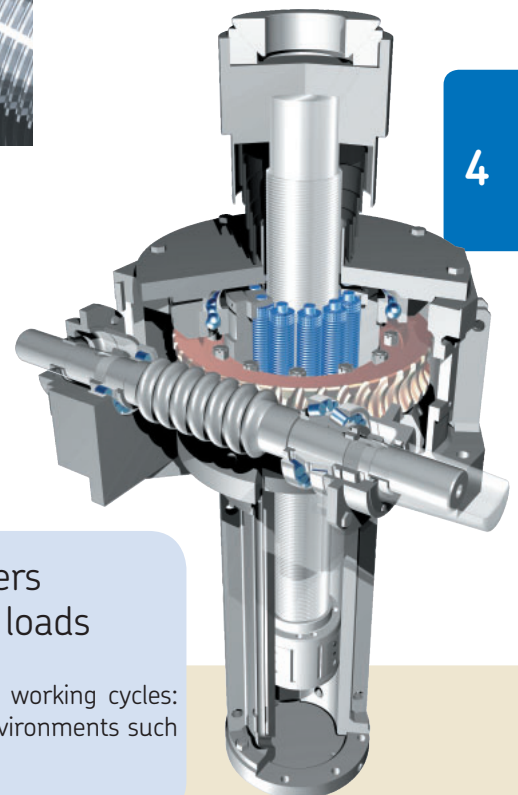



Contacts

www.ball-rollerscrews@skf.com
transrol.france@skf.com

Actuation
Ball & Roller screws



Represented by:

SKF is a registered trademark of the SKF Group.

© SKF Group 2005-2008

The contents of this publication are the copyright of the publisher and may not be reproduced (even extracts) unless prior written permission is granted. Every care has been taken to ensure the accuracy of the information contained in this publication but no liability can be accepted for any loss or damage whether direct, indirect or consequential arising out of the use of the information contained herein.