

# GFR GFRN

## TYPE



GFR

GFRN

Types GFR,GFRN are roller type freewheels. These units are part of the Stieber modular system. They are bearing supported, using two 160.. series bearings, and require oil lubrication. These units may be used in designs providing oil lubrication and sealing as on the example overleaf. The bearings must not be axially stressed.

Typically, types GFR,GFRN are used with the F series covers that are designed to transmit torque, and provide oil lubrication and sealing. Usually these covers are used

in pairs according to combinations shown on the following pages. The outer race of the GFR model is plain to receive and center any component bored to H7 tolerance.

Torque is transmitted by bolts through the cover plate in this case. Types GFR, GFRN are identical except that type GFRN has a keyway on the outside diameter to transmit the torque. Two paper seals are delivered with each unit to be placed between the outer race and cover plates.

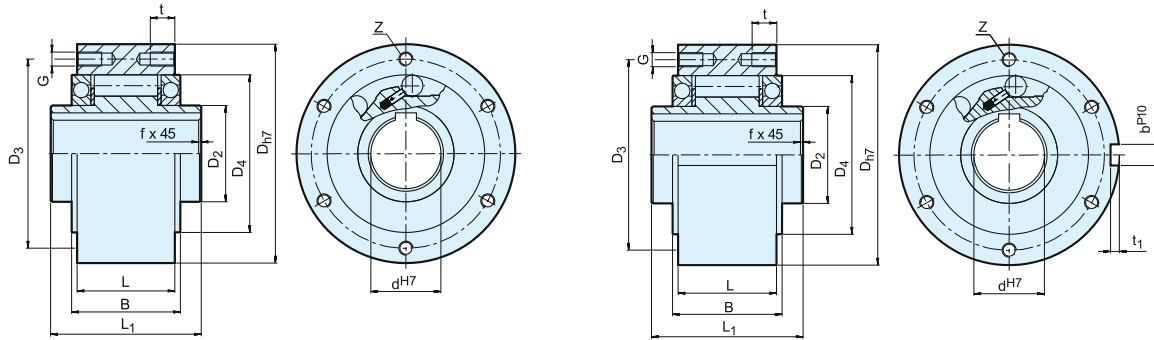

GFR

GFRN

Type	Size	Overrunning speeds							Number							Weight		
		$d_{H7}^{(1)}$ [mm]	$T_{KN}^{(1)}$ [Nm]	$n_{imax}^{(2)}$ [min <sup>-1</sup> ]	$n_{amax}^{(3)}$ [min <sup>-1</sup> ]	$D_{H7}$ [mm]	$D_2$ [mm]	$D_4$ [mm]	$D_3$ [mm]	G	t [mm]	z	$L_1$ [mm]	L [mm]	B [mm]		$t_1$ [mm]	$b^{P10}$ [mm]
GFR GFRN	12*	55	4000	7200	62	20	42	51	ø5.5	—	3	42	20	27	2.5	4	0.5	0.5
	15	125	3600	6500	68	25	47	56	M5	8	3	52	28	32	3	5	0.8	0.8
	20	181	2700	5600	75	30	55	64	M5	8	4	57	34	39	3.5	6	0.8	1.0
	25	288	2100	4500	90	40	68	78	M6	10	4	60	35	40	4	8	1.0	1.5
	30	500	1700	4100	100	45	75	87	M6	10	6	68	43	48	4	8	1.0	2.2
	35	725	1550	3800	110	50	80	96	M6	12	6	74	45	51	5	10	1.0	3.0
	40	1025	1150	3400	125	55	90	108	M8	14	6	86	53	59	5	12	1.5	4.6
	45	1125	1000	3200	130	60	95	112	M8	14	8	86	53	59	5.5	14	1.5	4.7
	50	2125	800	2800	150	70	110	132	M8	14	8	94	64	72	5.5	14	1.5	7.2
	55	2625	750	2650	160	75	115	138	M10	16	8	104	66	72	6	16	2.0	8.6
	60	3500	650	2450	170	80	125	150	M10	16	10	114	78	89	7	18	2.0	10.5
	70	5750	550	2150	190	90	140	165	M10	16	10	134	95	108	7.5	20	2.5	13.5
	80	8500	500	1900	210	105	160	185	M10	16	10	144	100	108	9	22	2.5	18.2
	90	14500	450	1700	230	120	180	206	M12	20	10	158	115	125	9	25	3.0	28.5
	100	20000	350	1450	270	140	210	240	M16	24	10	182	120	131	10	28	3.0	42.5
	130	31250	250	1250	310	160	240	278	M16	24	12	212	152	168	11	32	3.0	65.0
150	70000	200	980	400	200	310	360	M20	32	12	246	180	194	12	36	4.0	138.0	

**NOTES**

- 1)  $T_{max} = 2 \times T_{KN}$   
» Refer to Selection page 10 to 13
- 2) Inner race overruns. Values without radial lip seals
- 3) Outer race overruns. Values without radial lip seals  
Keyway to DIN 6885.1
- \* ) GFR12 has through holes in outer race  
» Refer to mounting and maintenance instructions  
page 16 to 19

**MOUNTING EXAMPLE**

