

FLURO-Gelenklager GmbH

**SPHERICAL PLAIN
BEARINGS AND ROD
ENDS FOR HEAVY-DUTY
APPLICATIONS**



Introduction

According to DIN ISO 12240-1, radial spherical plain bearings are standardized, ready-to-fit machine parts. Spherical plain bearings can perform circular movements, i.e., movements in circumferential direction (pivoting or rotating movements) and/or movements perpendicular to the bearing axis (tilting), all of which can compensate for misalignments and manufacturing inaccuracies as well as settling occurring in foundations.

FLURO has over 35 years of experience in the development and manufacture of spherical plain bearings and rod ends. To meet increasing customer requirements with sophisticated and high-risk applications under dynamic load conditions, FLURO has spent years of research developing FLUROGLIDE.



Figure 1: Performance characteristics

FLUROGLIDE is used in the series **GE..EW-2RS**, **GE..GW-2RS**, **GE..CW(-2RS)**, **GE..SWE**, **GE..AWE** as well as the cylindrical sliding bushings **GB..x..x..ZW**.

FLURO-Gelenklager GmbH

Table of Contents

General

Introduction.....2
 Contents3
 Performance Charts4
 Designs/Series5

Technical Information

Load Ratings6
 Internal and Operating Clearance7
 Bearing Design8
 Assembly and Disassembly Measures9
 Service Life and Working Life 11
 Calculating Service Life..... 12
 Calculation Process..... 15
 Calculation Example..... 16

Products

Radial Spherical Plain Bearings GE...EW-2RS..... 17
 Radial Spherical Plain Bearings GE...GW-2RS 18
 Large Radial Spherical Plain Bearings GE...CW(-2RS)..... 19
 Rod Ends Series EI...EW-2RS20
 Rod Ends Series EA...EW-2RS21
 Angular Spherical Plain Bearings Series GE...SWE.....22
 Axial Spherical Plain Bearings Series GE...AWE.....23

Cylindrical Sliding Bushings GB...x...x...ZW.....24

Service Life Calculation Specifications26

Special Applications27



Catalog Edition 2013

Every care has been taken to ensure the accuracy of the information in this catalog. However, no liability can be accepted for any errors or omissions. Due to continuing technical advances, we reserve the right to alter our products without notice.

FLURO-Gelenklager GmbH

Performance Charts

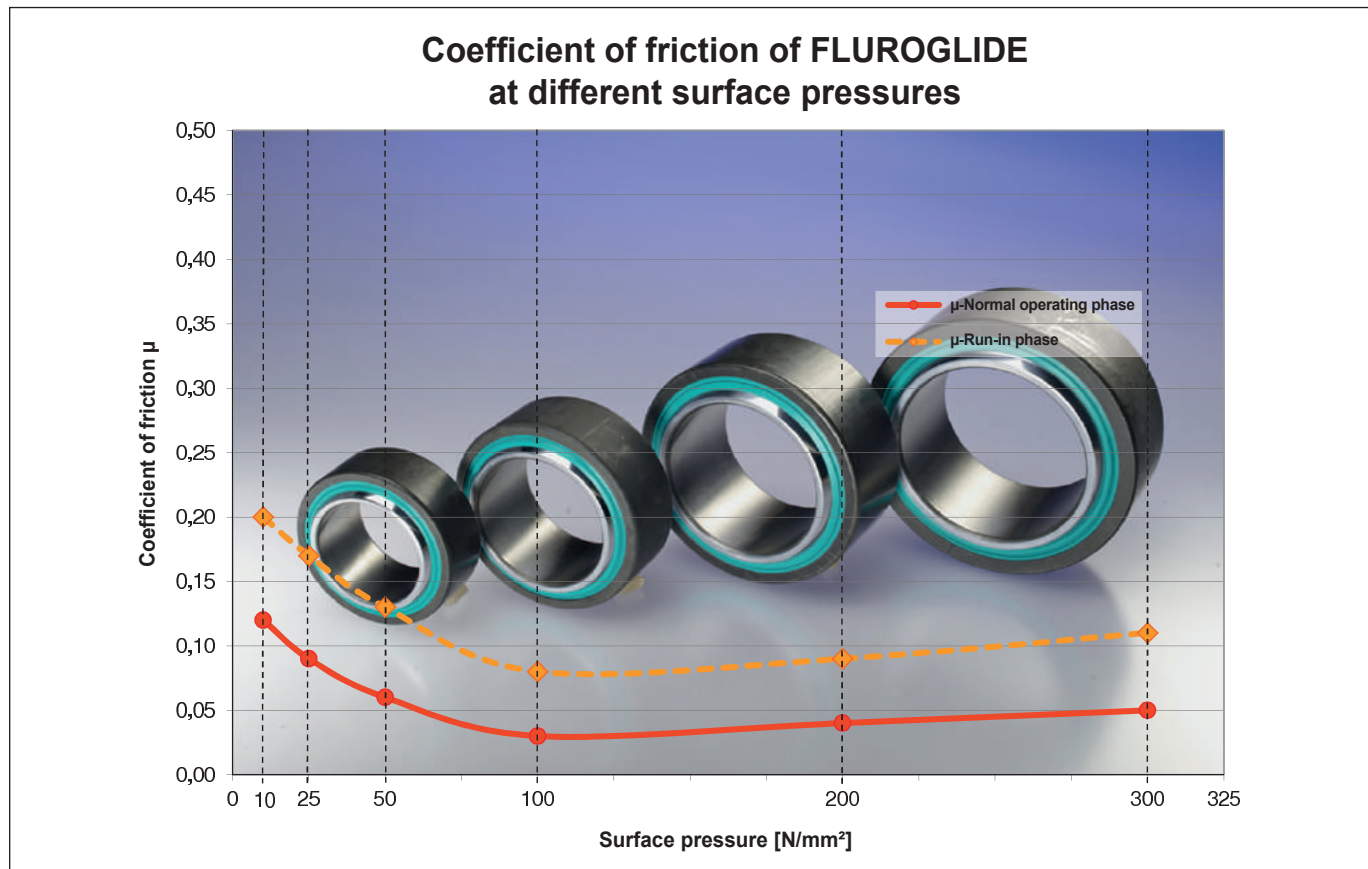
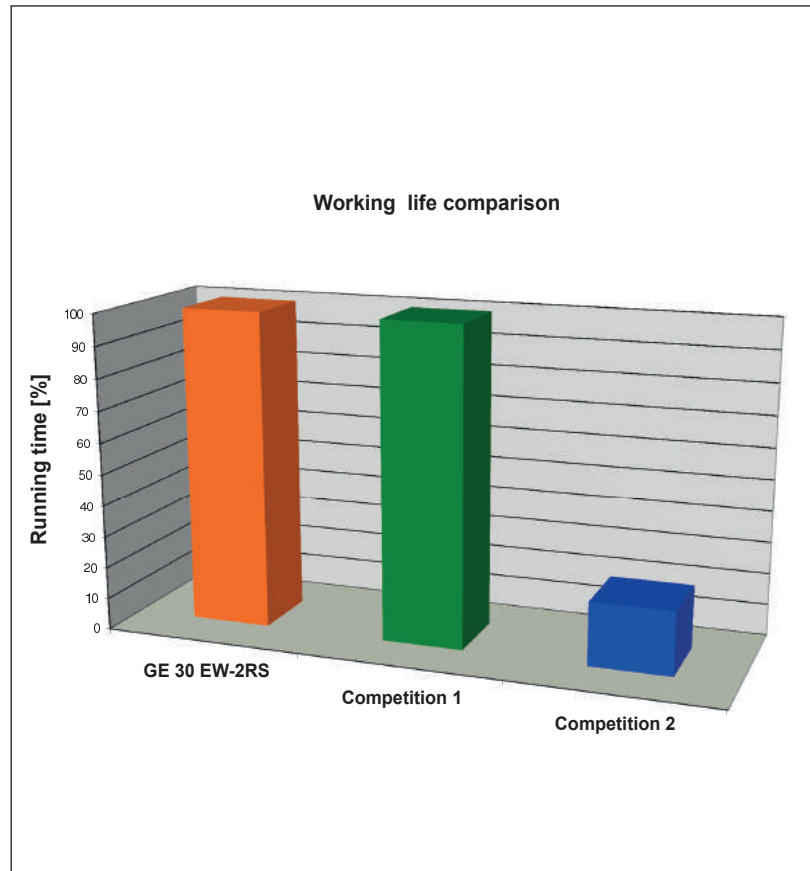
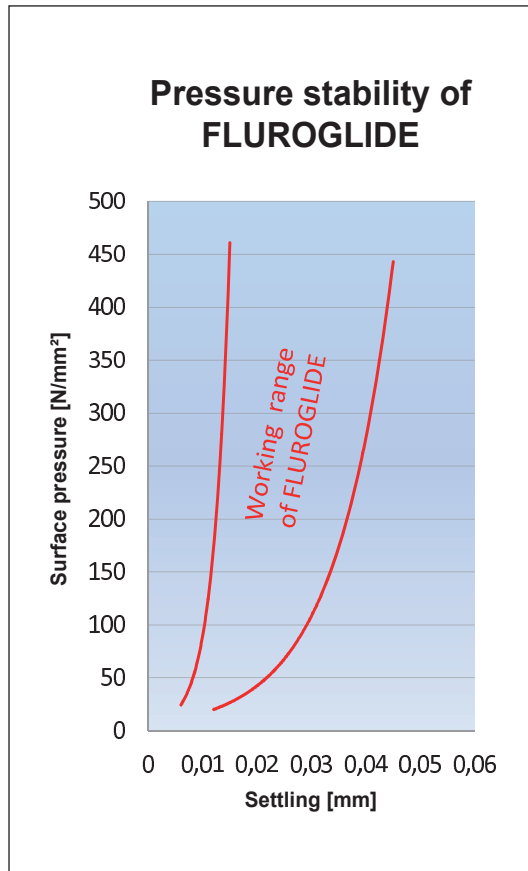

FLURO-Gelenklager GmbH

Designs / Series

Product Overview

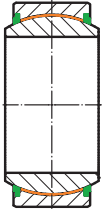
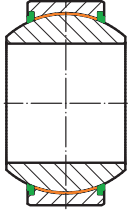
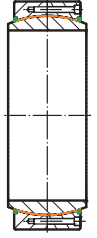
| Spherical Plain Bearings DIN ISO 12240-1 Series E | | | Spherical Plain Bearings DIN ISO 12240-1 Series G | | | Spherical Plain Bearings DIN ISO 12240-1 Series C | | |
|--|------------------|---|--|------------------|--|--|------------------|---|
| GE.. EW-2RS | Maintenance free |  | GE.. GW-2RS | Maintenance free |  | GE.. CW-2RS | Maintenance free |  |

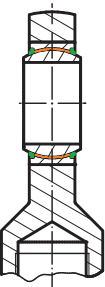
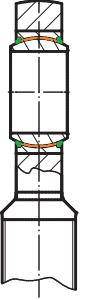
| Rod Ends DIN ISO 12240-4 Series E with Female Thread | | | Rod Ends DIN ISO 12240-4 Series E with Male Thread | | |
|---|------------------|---|---|------------------|--|
| EI.. EW-2RS | Maintenance free |  | EA.. EW-2RS | Maintenance free |  |

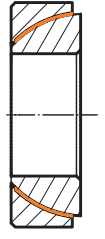
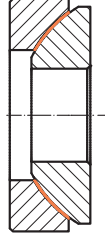
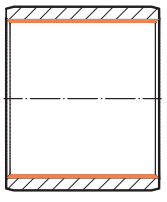
| Angular Spherical Plain Bearing DIN ISO 12240-2 | | | Axial Spherical Plain Bearing DIN ISO 12240-3 | | | Cylindrical Sliding Bushing DIN ISO 4379 | | |
|--|------------------|---|--|------------------|--|---|------------------|---|
| GE..SWE | Maintenance free |  | GE..AWE | Maintenance free |  | GB.x.x.ZW | Maintenance free |  |

The main dimensions and tolerances of the spherical plain bearings GE..EW-2RS and GE..GW-2RS correspond with DIN ISO 12240-1 before splitting the outer ring. Splitting the ring results in minor dimensional and shape deviations, which are eliminated when installing the bearings into the housing bore.

Load Ratings

The load bearing capacity of spherical plain bearings is defined by the bearing manufacturer with the dynamic load rating C and the basic static load rating C₀ and is not content of DIN ISO 12240. The load rating comparison of spherical plain bearings from different manufacturers is only viable if the bearing dimensions, the tribological pairing and the calculation method are identical.

Dynamic Load Rating C

– This is a characteristic value for the calculation of the theoretical service life when used under dynamic load conditions. For maintenance free bearings, each repeat movement is considered movement under dynamic load conditions. If the main movement is superimposed by relative movements, which also produce friction and wear, these must be added to the main movement and assigned to the dynamic operation.

Only the dynamic load rating C is applied for the theoretical service life calculation of maintenance free bearings!

C is determined by the load/bearing pressure, lubrication conditions, and the installation situation. An exact determination of the bearing pressure is complicated by many factors. The dynamic load rating C therefore considers a material-specific load factor K (see Table 1: Specific dynamic load factor) and the projected functional area of the bearing.

$$C = K \cdot \text{projected functional area of the bearing (in N)}$$

| Tribological pairing From outer to inner ring | Specific load factor K (N/mm ²) |
|--|--|
| FLUROGLIDE/Hard chrome | 300 |

Table 1: Specific dynamic load factor

| Tribological pairing From outer to inner ring | Specific load factor K ₀ (N/mm ²) |
|--|---|
| FLUROGLIDE/Hard chrome | 500 |

Table 2: Specific static load factor

Static Load Rating C₀

– Is applied at idle load after, for example, a single adjustment movement, or when dynamically loaded plain bearings are also exposed to additional impact loads.

C₀ is the load limit at room temperature for spherical plain bearings at which sliding surface damages may not yet occur. The bearing-surrounding components/materials of the bearing mating structures must be interpreted accordingly in terms of strength when fully utilizing C₀.

C₀ determined from the material-specific load factor K₀ (see Table 2: Specific static load factor) and the projected functional area of the bearing.

$$C_0 = K_0 \cdot \text{projected functional area of the bearing (in N)}$$

Internal and operating clearance

The radial clearance and the operating clearance of a bearing consists of the radial displacement of the inner part (inner ring, shaft, bolt, etc.) in the outer ring (sliding bushing) on the Y-/vertical axis.

The radial clearance in spherical plain bearings are manufacturer-specific and should primarily provide optimum functionality.

The addition of production, form and position tolerances means the radial clearance is specified in the tables for the series E, G and C.

Maintenance free spherical plain bearings require no radial clearance for layers of lubrication film.

At radial clearance = 0, the load share in the bearing amounts to 100%.

Our standard spherical plain bearings of the dimensional series E, C and G are supplied with a very narrow radial clearance range (see Table 3).

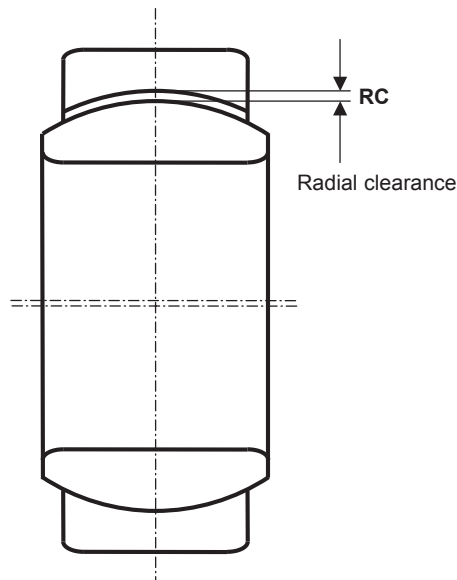

| Nominal size to | 20 | 35 | 60 | 90 | 140 | 240 | 300 | 340 | 400 |
|---|------|------|------|-------|-------|------|------|-------|-------|
| Radial clearance ¹ = (mm) from 0 to | 0.04 | 0.05 | 0.06 | 0.072 | 0.085 | 0.10 | 0.11 | 0.125 | 0.135 |

Table 3: Radial clearance

Each radial spherical plain bearing also has axial clearance, which can be about 3 times larger than the radial clearance due to geometric reasons. The axial clearance is not listed in the tables.

The operating clearance is determined on the installed bearing being warm from use.

The radial clearance, its reduction due to interferences, and the temperature effects in the installed state comprise the operating clearance.

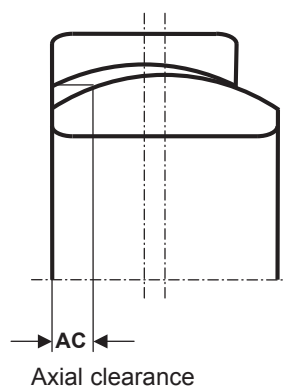

¹ The radial clearance is measured and guaranteed with manufacturer-specific test equipment.

Bearing Design

Appropriate measures must be taken to ensure the pivoting, tilting or rotating movements always take place between the functional surfaces of the bearing.

angle in the spherical plain bearing and especially in variable load applications, tighter fits are the better solution.

Due to the relatively low friction values of maintenance free bearings, looser fits for housing and shaft/bolt can be used. With regard to load share and load

| Fit recommendation: | Bore d (mm) | Housing/shaft Steel/steel | Housing/shaft Light metal/steel |
|---------------------|-----------------------------|----------------------------------|---------------------------------|
| | up to 300 300 and higher | K7 / j6 J7 / j6 | J7 / j6 - |

Selection as Locating Bearing

Housing and shaft fits must be in accordance with the installation recommendations. If looser fits must be selected due to installation conditions, the outer and inner ring should be subjected to additional friction-lock fixing established through the bearing mating structure.

Selection as Floating Bearing

Spherical plain bearings are always defined as floating bearings by the inner ring bore and the receiving shaft/bolt.

Axial force on the inner ring can lead to expansion of the housing bore. Therefore, the outer rings of the bearing must be firmly fixed in the housing bore.

If thermal or intentional axial displacements occur due to loads, these must take place in the inner ring bore. The inner ring width is the larger supporting surface. The counter mate bolt/shaft should have a surface hardness of HRC > 56 and a maximum roughness of Rz10.

An additional sliding lacquer treatment would be beneficial. The additional lining of the inner ring bore with FLUROGLIDE acc. to H8 (inner ring bore d in H8) is the more elegant problem solution and is available on request.

Assembly and Disassembly Measures

Spherical plain bearings and sliding bushings are precision machine parts. Trouble-free performance requires careful handling prior to and during installation.

The warranty is voided by installation errors.

When delivered, the bearings are preserved and can be taken directly out of the box and installed where needed. Do not alter the delivery condition and leave the bearings in the packaging until ready to install. The bearings should be stored in clean, dry areas.

For the prevention of corrosion, make sure the bearings are handled dry and clean.

Thermal installation tools with thermostat are permitted if heating/subcooling takes place evenly across the bearing-specific temperature range (-50 to +180 °C¹).

A visual inspection to check the dimensions and form accuracy of the bearing seats and the presence of centering chamfers in the range of $15 \pm 5^\circ$ (see Fig. 2) are part of the installation preparation process.

Slight oiling of the mounting surfaces to aid installation is permitted if oil does not reach the function zone of the bearing as a result. Direct blows to the bearing rings are not permitted. To ensure proper installation, appropriate assembly and installation tools (see Fig. 4 and 5) must be prepared. Direct the installation forces only indirectly onto the inner ring front face for mounting on a shaft/bolt or the outer ring end surface for mounting in a housing using a push-fit cap.

A combination installation tool (see Fig. 5) is needed when the mounting force simultaneously passes through the outer and inner ring faces and the bearing is mounted synchronously on a shaft/bolt and into a housing.

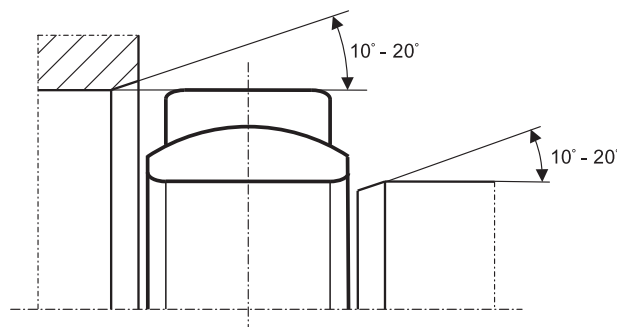

Figure 2: Centering chamfers

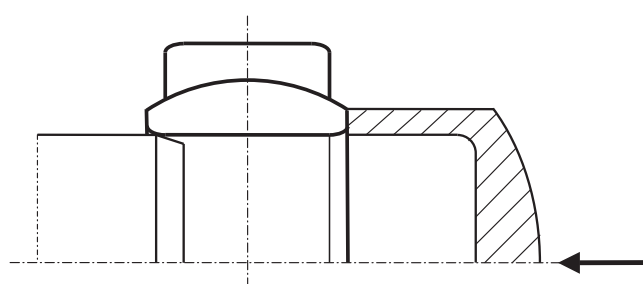

Figure 3: Installation tool

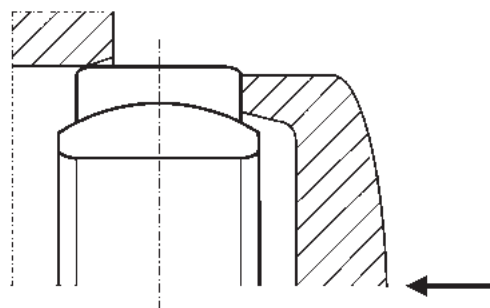

Figure 4: Installation tool

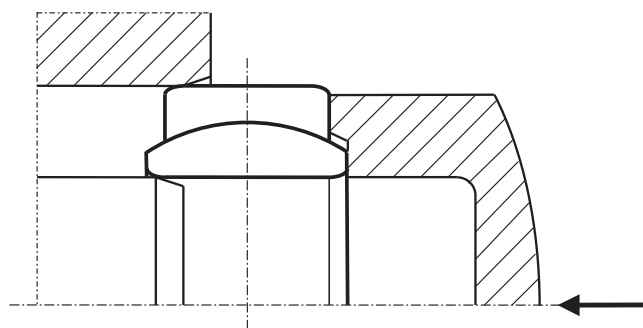

Figure 5: Combination installation tool

¹ To avoid damage to the seals, the seals must be removed from the housing before mounting with thermal installation tools (from 130 °C).

Assembly and Disassembly Measures

The mounting forces increase when the bearing dimensions increase. Appropriate assembly and reassembly options must therefore be provided as early as the design stage.

⚠ If split outer rings are installed, align the separation point approximately 90° to the direction of the main load.

The outer ring of the large spherical plain bearings GE...CW is screwed on one side. Having the screw/bolt pattern face the mounting side may facilitate a possible bearing replacement.

The threaded holes for eyebolts according to DIN 580 in the end faces are provided for handling and transport (see Fig. 6).

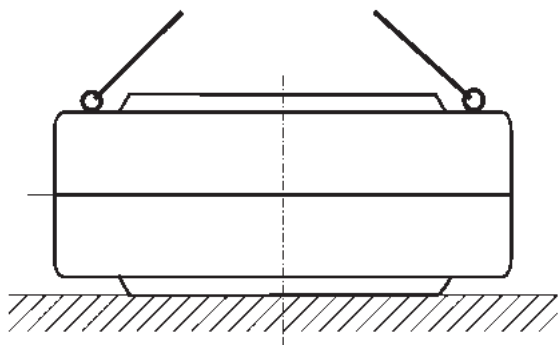

Figure 6: Transporting large spherical plain bearings

Maintenance and Handling of Spherical Plain Bearings

Maintenance free bearings by FLURO require absolutely no maintenance!

Do not lubricate maintenance free bearings. The intrinsic tribology of the bearing or its structure is significantly disrupted by lubrication, reducing service/working life radically.

The same applies to the penetration of liquids/contaminants of all types.

High glide/wear distances can only be achieved with dry running and functioning bearings with intrinsic tribology.

Make sure the inner ring is clean and dry after installing. Any residue of grease or oil must be removed with ethanol.

Service Life and Working Life

Service Life and Working Life

A variety of test bench and laboratory experiments under different load, motion ratios and conditions are the basis for the service life and the theoretical calculations.

The efforts to make the tests as practical as possible are faced with natural limits, so that theory and application experience must be merged.

Whether the user or FLURO carries out the calculation, the specifications (page 26) must list the complete technical data.

The calculation of the theoretical service life definitely delivers comparable bearing benchmarks. These can be used to pick the bearing with the best performance among those offered by various providers.

Results may be compared only when provider, product, and theoretical calculation have the same point of origin. The oscillations achieved in practice (pivoting movements) or operating hours comprise the working life of the bearing.

The working life is largely determined by the following:

- Proper bearing selection
- Occurring impacts, shocks, knocks, vibrations
- Aggressive corrosion
- Implementation of installation recommendations
- Type and size of the load
- Contaminants, pollution
- Seal functionality

Friction and Wear

Friction in maintenance free bearings depends on the following:

- Tribological pairing (sliding layer in the outer ring/ counter mate inner ring or shaft/bolt)
- Load
- Sliding speed
- Operating temperature

Friction is a function of the load (P). Depending on the sliding layer, the friction decreases with increasing load. The friction increases when the load is reduced. This means friction is a direct function of the sliding speed (v). Friction increases and decreases with increasing or decreasing sliding speed. Friction is also a function of the operating temperature T_B . Reciprocally (inverse function), friction increases and decreases with dropping or rising temperature.

Safety reasons require calculating the bearing friction moment when dimensioning the drive units always with the maximum friction factor for FLUROGLIDE high-performance sliding liners compared with hard chromium or hardened steels. The maximum coefficient of friction occurs in the run-in phase.

FLUROGLIDE is characterized in particular by the fact that the coefficient of friction exhibits a low friction level even during the run-in phase.

Depending on the load, well run-in bearings move during the normal operating phase on an almost constant friction level up until the failure phase.

$$M = P \times \mu \times d_k \times 5 \times 10^{-4}$$

M (Nm) = spherical plain bearing - bearing friction moment

P (N) = equivalent, dynamic load

μ = friction factor
(see friction value table on page 4)

d_k (mm) = spherical plain bearing - ball diameter
(from product tables)

Service Life and Working Life

Development focused on an optimized run-in phase of the spherical plain bearing value to achieve an extension of the normal operating phase.

Range: $p = 1 - 300 \text{ N/mm}^2$

$$s = 1500000 / 1.0219P \text{ to } p \leq 100 \text{ N/mm}^2$$

$$s = 800000 / 1.0155P \text{ from } p \geq 100 - 300 \text{ N/mm}^2$$

Increased friction values are synonymous with increased wear in the run-in and run-out phases.

A constant coefficient of friction in the normal operating phase reflects the linear wear, which is the result of a trouble-free, properly functioning intrinsic bearing tribology, effected by the continuous replacement of used slide lining particles.

The task of a seal must be to protect the intrinsic tribology from all physical and chemical influences.

If underchallenged in terms of the load and moving at a high friction level, such a bearing installed in a vibration-sensitive design can be the cause of unpleasant noise (slip-stick).

All previous statements relate to the FLUROGLIDE high-performance liner in the outer ring. The influence of the counter mate inner ring spherical surface, shaft or bolt surface is similar in size and is considered in the service life calculation with the following factors.

$$\text{Roughness Factor } f_6 = 1.357 \times 0.737^{Rz}$$

(Materials:

Hard chrome, roller bearing, carbon or hardened stainless steels)

$$\text{Hardness Factor } f_7 = 1 - (55 - \text{HRC actual value}) \times 0.04$$

The spherical plain bearings form a closed unit, in which roughness $f_6 = 1$ and hardness $f_7 = 1$ are optimally realized. If the spherical plain bearing is used as a floating bearing, the responsibility lies with the user - when the counter mate is a shaft or bolt, the requirements for material, roughness and hardness must be considered.

Loads

In moving bearings, a distinction is made between an unchanging, central load **F** (constant, unidirectional load) and a composite, equivalent load **P**, from simultaneously acting radial (**Fr**) and axial (**Fa**) loads (see Fig. 7), which can also occur unidirectional or alternating. If **F** is active, **F = P** and is included directly in the calculation of the theoretical service life. If composite loads are active, **P** must be determined first.

$$P = X \times Fr \quad X = 0.97 \times 26.565^{Fa/Fr}$$

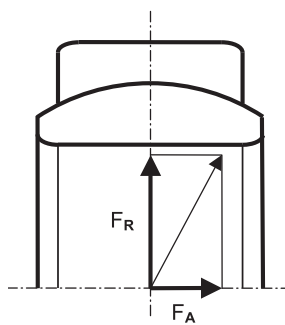

Figure 7: Radial and axial force

 Please note: The ratio of F_a/F_r may not exceed **0.3**.

Service Life and Working Life

Variable Loads

The equivalent load value **P** for a linearly variable load is determined as follows:

$$P = [(F_{\min}^2 + F_{\max}^2) \times 0.5]^{0.5}$$

If pulsating loads occur, **F_{max}** represents a calculation on the safe side. With varying load directions (traction/compressive forces), the maximum load **P_{max}** is always included in the calculation. The theoretical service life, in the order calculated first for an unidirectional load, is corrected using a variable load factor **f₅**.

| | |
|-----------------------------|---|
| Variable Load Factor | f₅ = 0.5442 / 1.017^{f₄} × p |
|-----------------------------|---|

| | |
|-----------------------|-------------------------------|
| Load Frequency | f₄ = f / 60 |
|-----------------------|-------------------------------|

Load frequency $f_4 = f / 60$ in (Hz) when $f = f_4$. $f \neq f_4$ then used for f_4 the load frequency specified by the customer since movement and load frequencies may differ.

Contact/Bearing Pressure

If the target service lifespan is to become reality, the specific bearing must match the operating conditions. The specific bearing load determines the contact pressure in the bearing and is the criterion for the assessment based on the particular application case.

The contact/bearing pressure **p** of a radial spherical plain bearing is determined from the following:

- Specific load factor
K = 300 (N/mm²) Table 1 Page 6
- Equivalent dynamic bearing load
P (N) (see above)
- Dynamic load rating
C (N) (from dimensional tables)

| | |
|---------------------------------|----------------------|
| Contact/Bearing Pressure | p = 300 × P/C |
|---------------------------------|----------------------|



- Dynamic constant and pulsating load
P_{max} = 300 N/mm²
- Variable load
P_{max} = 150 N/mm² (p=150 N/mm² at f₄ = 0,67Hz)
- Static load
P_{0max} = 500N/mm²

Movements

Spherical plain bearings during dynamic operation transfer high loads, while outer and inner ring are moving relative to one another.

The movements (dynamic conditions) are determined by the following:

- Kinetic momenta
- Movement frequency
- Movement speed

Service Life and Working Life

Kinetic Momenta

The pivoting angle β is one of the kinetic momenta (see Fig. 8). It describes the bearing movement in the circumferential direction from one end position to the other. One pivotal movement comprises 2β , i.e., from one end position to another and back.

At a maximum pivoting angle $\beta = 180^\circ$, a pivotal movement amounts to $= 2\beta = 360^\circ = 1$ revolution.

The tilting angle α also is one of the kinetic momenta. It describes the bearing movement transverse to the bearing axis. A tilting movement comprises 2α . The maximum tilting angle with full utilization of the catalog load ratings is listed in the respective dimension tables. In theory, a radial spherical plain bearing with reduced load rating can be tilted up to the stop of the shaft/bolt in the outer ring. If pivoting and tilting movements occur simultaneously, the spherical plain bearing carries out spherical movements.

The replacement angle β_1 is determined through geometric addition. The movement angles are considered by an angle factor f_2 in the theoretical calculation of the service life.

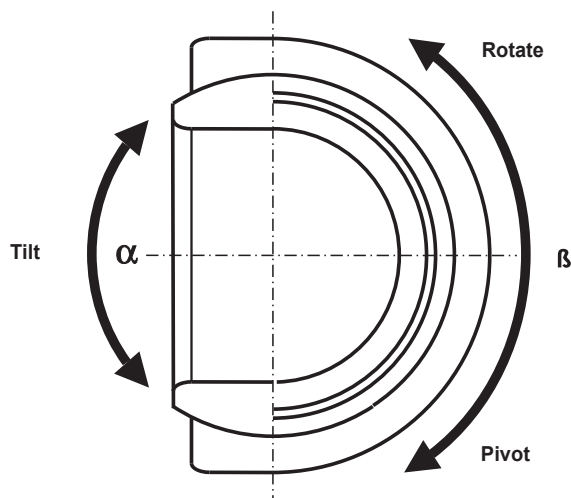

Figure 8: Tilting and pivoting angle

| | |
|--|---|
| $\beta_1 = (\beta^2 + \alpha^2)^{0.5}$ | $f_2 = 0.758 \times 1.00618^{\beta \text{ or } \alpha \text{ or } \beta_1}$ |
|--|---|

Movement Frequency

Movement frequency, also called frequency f (min^{-1}), designates the number of movements per time unit. In case of rotary movements, f is replaced by n .

The frequency primarily influences the service life of the bearing as well as the friction energy turnover in the spherical plain bearing.

Movement Speed

Movement speed for maintenance free spherical plain bearings is the average sliding speed v (mm/s), which prevails in continuous operation, or in operation with recurring downtimes.

The sliding speed is considered during the calculation by a sliding speed factor f_1 .

| | |
|--|--|
| $v = 2.91 \times 10^{-4} \times d_k \times \beta \times f$ | $f_1 = 1.61 - (v \times 1.01^P / 366.3)$ |
|--|--|

Operating Temperature T_B

The permissible operating temperatures of the FLURO-GLIDE high-performance liner amount to -30 to $+150^\circ\text{C}$. In the range of 0 to $+150^\circ\text{C}$, the temperature factor is $f_3 = 1$; a service life reduction occurs from 0 to -30°C .

| |
|------------------------------------|
| $f_3 = 1 - [-20 - (-T_B)] / 100$ |
|------------------------------------|

Scope of Applicability

! The theoretical service life calculation is valid in the range of $d = 17$ to 300 . To calculate the spherical plain bearings of the series **CW**; **AWE** and **SWE**, please contact our technical staff.

Service Life and Working Life

Calculation Sequence

A preliminary bearing definition and step-by-step theoretical service life determination for the corresponding spherical plain bearing is based on the technical data from the specifications (see calculation example). This starts with the calculation of unidirectional and pulsating loads; later the result is corrected with the variable factor once traction/pressure is applied to the bearing.

- | | |
|--|--|
| 1. Load | P (kN) |
| Unidirectional or alternating load..... | $F_r = P$ |
| Equivalents, unidirectional, or alternating load..... | $P = 0.97 \times 26.565^{F_a/F_r} \times F_r$ |
| Pulsating load..... | $P = [(F_{min}^2 + F_{max}^2) \times 0.5]^{0.5}$ |
| <i>Using F_{max} for the theoretical service life calculation represents a calculation that is on the safe side.</i> | |
| 2. Bearing Pressure | p (N/mm²) |
| Specific bearing load..... | $P = 300 \times PIC$ (C = dynamic load rating from product table) |
| 3. Glide/Wear Distance | s (m) |
| Up to $p \leq 100$ N/mm ² $s = 1,500,000 / 1.0219^p$ | From $p \geq 100 - 300$ N/mm ² $s = 800,000 / 1.0155^p$ |
| 4. Sliding Speed | v (mm/s) |
| From 1 – 300 mm/s..... | $v = 2.91 \times 10^{-4} \times d_k \times \beta \times f$ |
| <i>In case of sliding bushing d instead of d_k from the dimension tables; if pivoting or spherical movements; α or β_1 ($\beta_1 = (\beta^2 + \alpha^2)^{0.5}$) and with rotary movements n instead of f. (f in min⁻¹)</i> | |
| 5. Slide Speed Factor f_1 | 6. Movement Factor f_2 |
| $f_1 = 1.61 - [(v \times 1.01^p) / 366.3]$ | $f_2 = 0.758 \times 1.00618^\beta$ |
| 7. Temperature Factor f_3 | |
| From 0 to +150°C $f_3 = 1$ | From 0 to -30° C $f_3 = 1 - [-20 - (T_B)] / 100$ |
| 8. Theoretical Service Life | |
| L In pivoting movements / oscillations | L_h In operating hours |
| $L = s \times f \times f_1 \times f_3 \times 10 / v \times f_2$ | $L_h = L / (f \times 60)$ |

Theoretical Service Life with Variable Load

- | | |
|--|--|
| Load frequency factor f_4 | Variable load factor f_5 |
| $f_4 = f / 60$ | $f_5 = 0.5442 / 1.017^{f^4} \times p$ |
| L_w In pivoting movements / oscillations | L_{hw} In operating hours |
| $L_w = L \times f_5$ | $L_{hw} = L_w / (f \times 60)$ |

Theoretical Service Life Calculation Sliding Bushing

For the calculation of the theoretical service life, the roughness and hardness must be taken into account by means of factors.

- | | |
|---|--|
| Roughness factor f_6 | Hardness factor f_7 |
| $f_6 = 1.357 \times 0.737^{Rz}$ | $f_7 = 1 - (55 - \text{HRC actual value}) \times 0.04$ |
| $L = s \times f \times f_1 \times f_3 \times f_6 \times f_7 / v \times f_2$ | $L_h = L / (f \times 60)$ |

If a variable load prevails, the calculation is as follows.

- | | |
|----------------------------|--------------------------------|
| $L_w = L \times f_5$ | $L_{hw} = L_w / (f \times 60)$ |
|----------------------------|--------------------------------|



Service Life and Working Life

Calculation Example

Customer:.....Crane manufacturer
Installation case/site:.....Jib bearing on double lever jib for grabbing operation
 According to DIN 15018 operating class V5
Environmental conditions:.....Temperature: From 5 to 60°C
 Atmosphere: Maritime climate
Minimum Bolt/Shaft Diameter200 mm
Loads:.....Radial loads: Axial loads:
 $F_{r \max} = 1,400 \text{ kN}$ $F_{a \max} = 70 \text{ kN}$
 $F_{r \min} = \text{n.n.}$ $F_{a \min} = \text{n.n.}$
Load Direction:.....Unidirectional / constant
Maximum bearing load (P) - distribution by FEM section IX, load spectrum 2
 4 Load cases: >Load case 1 = ED 16.6% (P) ; >Load case 2 = ED 50% ($P_1 = P \times 0.32$);
 >Load case 3 = ED 16.7% ($P_2 = P \times 0.227 + P_1$) ; >Load case 4 = ED 16.7% ($P_3 = P \times 0.453 + P_1$)
Movements:.....Pivoting $\beta = 32^\circ$ Time for $\beta = 0.5 \text{ min}$
Movement Frequency:.....Number of pivoting movements $f = 1 \text{ min}^{-1}$ during 16 hours/day
Customer Request:.....Theoretical service life of L_h 50,000 hours

Radial spherical plain bearings type GE200EW-2RS selected.

Bearing data: Dyn. load rating $C = 6,000 \text{ kN}$; ball diameter $d_K = 250 \text{ mm}$

Factors: Temperature factor $f_3 = 1$ (temperature from 0 to +150°C)

1. Load ($P = 0.97 \times 26.565^{F_a/F_r} \times F_r$)

Load case 1: $P = 0.97 \times 26.565^{70/1400} \times 1400 = \underline{1600 \text{ kN}}$; Load case 2: $P_1 = 1600 \times 0.32 = \underline{512 \text{ kN}}$

Load case 3: $P_2 = 1600 \times 0.227 + 512 = \underline{875.2 \text{ kN}}$; Load case 4: $P_3 = 1600 \times 0.453 + 512 = \underline{1236.8 \text{ kN}}$

2. Bearing pressure ($p = 300 \times P / C$)

Load case 1: $p = 300 \times 1600 / 6000 = \underline{80 \text{ N/mm}^2}$; Load case 2: $p_1 = 300 \times 512 / 6000 = \underline{25.6 \text{ N/mm}^2}$

Load case 3: $p_2 = 300 \times 875.2 / 6000 = \underline{43.76 \text{ N/mm}^2}$; Load case 4: $p_3 = 300 \times 1236.8 / 6000 = \underline{61.84 \text{ N/mm}^2}$

3. Glide/wear distance ($s = 1,500,000 / 1.0219^p$)

Load case 1: $s = 1,500,000 / 1.0219^{80} = \underline{265,106 \text{ m}}$; Load case 2: $s_1 = 1,500,000 / 1.0219^{25.6} = \underline{861,462 \text{ m}}$

Load case 3: $s = 1,500,000 / 1.0219^{43.76} = \underline{581,272 \text{ m}}$; Load case 4: $s = 1,500,000 / 1.0219^{61.84} = \underline{392,894 \text{ m}}$

4. Sliding speed ($v = 2.91 \times 10^{-4} \times d_K \times \beta \times f$)

$v = 2.91 \times 10^{-4} \times 250 \times 32 \times 1 = \underline{2.328 \text{ mm/s}}$

5. Sliding speed factor ($f_1 = 1.61 - [(v \times 1.01^p) / 366.3]$)

Load case 1: $f_1 = 1.61 - [(2.328 \times 1.01^{80}) / 366.3] = \underline{1.596}$; Load case 2: $f_1 = 1.61 - [(2.328 \times 1.01^{25.6}) / 366.3] = \underline{1.602}$

Load case 3: $f_1 = 1.61 - [(2.328 \times 1.01^{43.76}) / 366.3] = \underline{1.60}$; Load case 4: $f_1 = 1.61 - [(2.328 \times 1.01^{61.84}) / 366.3] = \underline{1.598}$

6. Movement factor ($f_2 = 0.758 \times 1.00618^\beta$)

$f_2 = 0.758 \times 1.00618^{32} = \underline{0.923}$

7. Theoretical service life ($L = s \times f \times f_1 \times f_3 \times 10 / v \times f_2$; $L_h = L / f \times 60$)

Load case 1: $L = 265,106 \times 1 \times 1.596 \times 1 \times 10 / (2.328 \times 0.923) = \underline{1,969,109}$ Pivoting movements

Load case 2: $L = 861,462 \times 1 \times 1.602 \times 1 \times 10 / (2.328 \times 0.923) = \underline{6,422,646}$ Pivoting movements

Load case 3: $L = 581,272 \times 1 \times 1.600 \times 1 \times 10 / (2.328 \times 0.923) = \underline{4,328,274}$ Pivoting movements

Load case 4: $L = 392,894 \times 1 \times 1.598 \times 1 \times 10 / (2.328 \times 0.923) = \underline{2,921,914}$ Pivoting movements

$$L_{\text{total}} = \frac{100}{\frac{16.6}{1,969,109} + \frac{50}{6,422,646} + \frac{16.7}{4,328,274} + \frac{16.7}{2,921,914}} = \underline{3,877,630} \text{ Pivoting movements}$$

$$L_h = L_{\text{total}} / (f \times 60)$$

$$L_h = 3,877,630 / (1 \times 60) = \underline{64,627 \text{ hours}} > 50,000 \text{ hours customer request}$$

If the calculated service life is not equal to the time requested by the customer, a larger spherical plain bearing must be used for the calculation.

FLURO-Gelenklager GmbH

Spherical Plain Bearings Series E

Series GE...EW-2RS

Spherical plain bearings series E, mating surface hard chrome/FLUROGLIDE, maintenance free

For use with high unidirectionally/variably acting loads

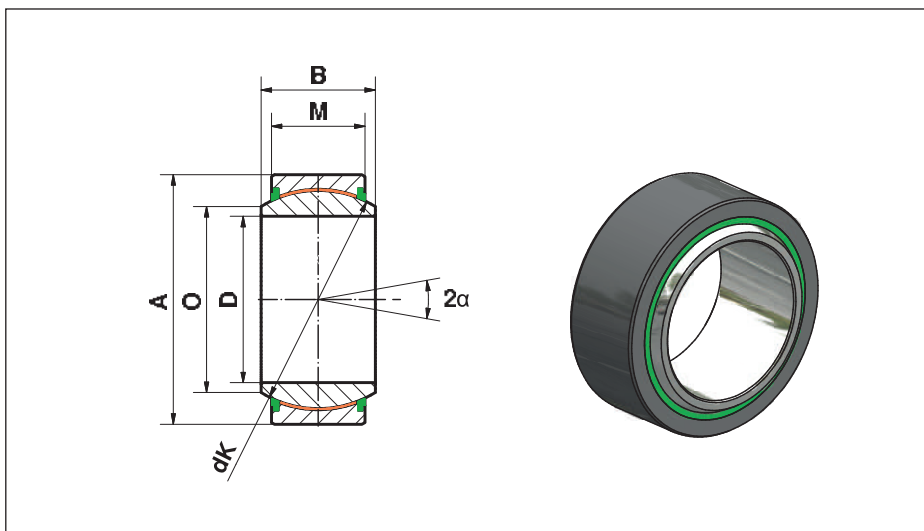

| Size (D) | B | M | A | O | dK | Static load ratings C ₀ kN | Dynamic load ratings C kN | Tilting angle α | Weight g |
|------------------------------------|-----|-----|------------------------------------|-------|-------|---------------------------------------|---------------------------|-----------------|----------|
| 17 ⁰ _{-0,008} | 14 | 10 | 30 ⁰ _{-0,009} | 20,7 | 25,0 | 81,2 | 48,7 | 10 | 37 |
| 20 ⁰ _{-0,010} | 16 | 12 | 35 ⁰ _{-0,011} | 24,1 | 29,0 | 112 | 67,5 | 9 | 60 |
| 25 ⁰ _{-0,010} | 20 | 16 | 42 ⁰ _{-0,011} | 29,3 | 35,5 | 212 | 127 | 7 | 110 |
| 30 ⁰ _{-0,010} | 22 | 18 | 47 ⁰ _{-0,011} | 34,2 | 40,7 | 275 | 165 | 6 | 140 |
| 35 ⁰ _{-0,012} | 25 | 20 | 55 ⁰ _{-0,013} | 39,7 | 47,0 | 350 | 210 | 6 | 220 |
| 40 ⁰ _{-0,012} | 28 | 22 | 62 ⁰ _{-0,013} | 45,0 | 53,0 | 462 | 277 | 7 | 300 |
| 45 ⁰ _{-0,012} | 32 | 25 | 68 ⁰ _{-0,013} | 50,7 | 60,0 | 600 | 360 | 7 | 390 |
| 50 ⁰ _{-0,012} | 35 | 28 | 75 ⁰ _{-0,013} | 55,9 | 66,0 | 737 | 442 | 6 | 530 |
| 60 ⁰ _{-0,015} | 44 | 36 | 90 ⁰ _{-0,015} | 66,8 | 80,0 | 1.150 | 690 | 6 | 980 |
| 70 ⁰ _{-0,015} | 49 | 40 | 105 ⁰ _{-0,015} | 77,8 | 92,0 | 1.472 | 883 | 6 | 1.500 |
| 80 ⁰ _{-0,015} | 55 | 45 | 120 ⁰ _{-0,015} | 89,4 | 105,0 | 1.875 | 1.125 | 6 | 2.200 |
| 90 ⁰ _{-0,020} | 60 | 50 | 130 ⁰ _{-0,018} | 98,1 | 115,0 | 2.300 | 1.380 | 5 | 2.700 |
| 100 ⁰ _{-0,020} | 70 | 55 | 150 ⁰ _{-0,018} | 109,5 | 130,0 | 2.860 | 1.716 | 7 | 4.200 |
| 110 ⁰ _{-0,020} | 70 | 55 | 160 ⁰ _{-0,025} | 121,2 | 140,0 | 3.075 | 1.845 | 6 | 4.700 |
| 120 ⁰ _{-0,020} | 85 | 70 | 180 ⁰ _{-0,025} | 135,5 | 160,0 | 4.475 | 2.685 | 6 | 8.100 |
| 140 ⁰ _{-0,025} | 90 | 70 | 210 ⁰ _{-0,030} | 155,8 | 180,0 | 5.025 | 3.015 | 7 | 10.600 |
| 160 ⁰ _{-0,025} | 105 | 80 | 230 ⁰ _{-0,030} | 170,3 | 200,0 | 6.400 | 3.840 | 8 | 13.800 |
| 180 ⁰ _{-0,025} | 105 | 80 | 260 ⁰ _{-0,035} | 198,9 | 225,0 | 7.200 | 4.320 | 6 | 17.400 |
| 200 ⁰ _{-0,030} | 130 | 100 | 290 ⁰ _{-0,035} | 213,5 | 250,0 | 10.000 | 6.000 | 7 | 28.000 |
| 220 ⁰ _{-0,030} | 135 | 100 | 320 ⁰ _{-0,040} | 239,5 | 275,0 | 11.000 | 6.600 | 8 | 35.500 |
| 240 ⁰ _{-0,030} | 140 | 100 | 340 ⁰ _{-0,040} | 265,3 | 300,0 | 12.000 | 7.200 | 8 | 39.000 |
| 260 ⁰ _{-0,035} | 150 | 110 | 370 ⁰ _{-0,040} | 288,3 | 325,0 | 14.250 | 8.550 | 7 | 50.800 |
| 280 ⁰ _{-0,035} | 155 | 120 | 400 ⁰ _{-0,040} | 313,8 | 350,0 | 16.750 | 10.050 | 6 | 64.700 |
| 300 ⁰ _{-0,035} | 165 | 120 | 430 ⁰ _{-0,045} | 366,7 | 375,0 | 18.000 | 10.800 | 7 | 76.600 |

In spherical plain bearings up to size 120, the hardened shell is split unilaterally due to assembly reasons. Starting with size 140, the spherical plain bearing consists of two hardened shells secured with a clamp and screw.

Materials:

Outer ring: Bearing steel 100Cr6, hardened and phosphated, with FLUROGLIDE bonded to the inner surface

Inner ring: Bearing steel 100Cr6, hardened, ground, polished, hard chrome plated

On request available in stainless steel

Please note that the numbers pointed off on the pages 17 to 23 and 25 in the data sheets, signalise a thousands place. And the numbers with thousands separators (comma) signalise a decimal point.

FLURO-Gelenklager GmbH

Spherical Plain Bearings Series G

Series GE...GW-2RS

Spherical plain bearings series G
 DIN ISO 12240-1,
 mating surface, hard chrome/FLUROGLIDE,
 maintenance free

Larger tilting angle due to wider inner ring

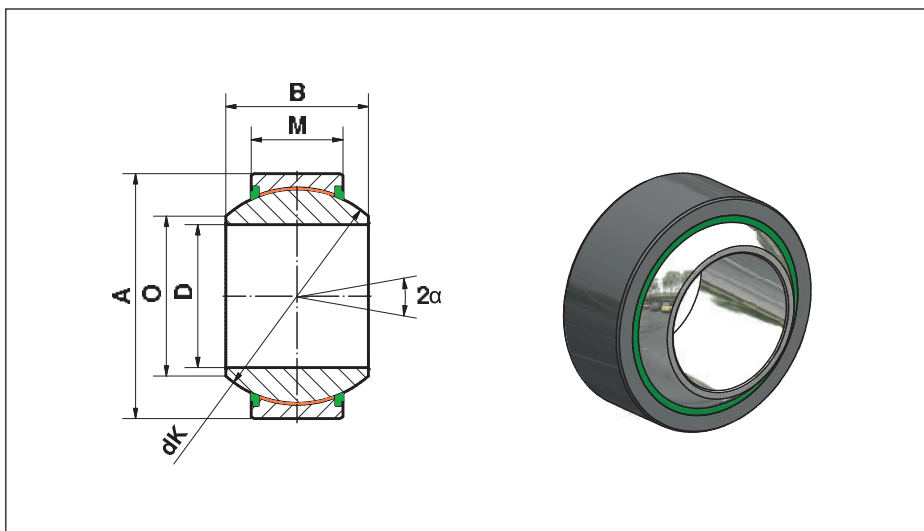

| Size (D) | B | M | A | O | dK | Static load ratings C ₀ kN | Dynamic load ratings C kN | Tilting angle α | Weight g |
|------------------------------------|-----|-----|------------------------------------|-------|------|---------------------------------------|---------------------------|-----------------|----------|
| 20 ⁰ _{-0,010} | 25 | 16 | 42 ⁰ _{-0,011} | 25,2 | 35,5 | 182 | 110 | 17 | 153 |
| 25 ⁰ _{-0,010} | 28 | 18 | 47 ⁰ _{-0,011} | 29,5 | 40,7 | 272 | 162 | 17 | 203 |
| 30 ⁰ _{-0,010} | 32 | 20 | 55 ⁰ _{-0,013} | 34,4 | 47 | 350 | 210 | 17 | 280 |
| 35 ⁰ _{-0,012} | 35 | 22 | 62 ⁰ _{-0,013} | 39,7 | 53 | 462 | 277 | 16 | 380 |
| 40 ⁰ _{-0,012} | 40 | 25 | 68 ⁰ _{-0,013} | 44,7 | 60 | 600 | 360 | 17 | 530 |
| 45 ⁰ _{-0,012} | 43 | 28 | 75 ⁰ _{-0,013} | 50,0 | 66 | 737 | 442 | 15 | 670 |
| 50 ⁰ _{-0,012} | 56 | 36 | 90 ⁰ _{-0,015} | 57,1 | 80 | 1.150 | 690 | 17 | 1.400 |
| 60 ⁰ _{-0,015} | 63 | 40 | 105 ⁰ _{-0,015} | 67,0 | 92 | 1.472 | 883 | 17 | 2.100 |
| 70 ⁰ _{-0,015} | 70 | 45 | 120 ⁰ _{-0,015} | 78,2 | 105 | 1.875 | 1.125 | 16 | 3.000 |
| 80 ⁰ _{-0,015} | 75 | 50 | 130 ⁰ _{-0,018} | 87,1 | 115 | 2.300 | 1.380 | 14 | 3.600 |
| 90 ⁰ _{-0,020} | 85 | 55 | 150 ⁰ _{-0,018} | 98,3 | 130 | 2.860 | 1.716 | 15 | 5.300 |
| 100 ⁰ _{-0,020} | 85 | 55 | 160 ⁰ _{-0,025} | 111,2 | 140 | 3.075 | 1.845 | 14 | 6.000 |
| 110 ⁰ _{-0,020} | 100 | 70 | 180 ⁰ _{-0,025} | 124,8 | 160 | 4.475 | 2.685 | 12 | 9.800 |
| 120 ⁰ _{-0,020} | 115 | 70 | 210 ⁰ _{-0,030} | 138,4 | 180 | 5.025 | 3.015 | 16 | 14.600 |
| 140 ⁰ _{-0,025} | 130 | 80 | 230 ⁰ _{-0,030} | 151,9 | 200 | 6.400 | 3.840 | 16 | 18.600 |
| 160 ⁰ _{-0,025} | 135 | 80 | 260 ⁰ _{-0,035} | 180,0 | 225 | 7.200 | 4.320 | 16 | 24.900 |
| 180 ⁰ _{-0,025} | 155 | 100 | 290 ⁰ _{-0,035} | 196,1 | 250 | 10.000 | 6.000 | 14 | 33.600 |
| 200 ⁰ _{-0,030} | 165 | 100 | 320 ⁰ _{-0,040} | 220,0 | 275 | 11.000 | 6.600 | 15 | 44.700 |
| 220 ⁰ _{-0,030} | 175 | 100 | 340 ⁰ _{-0,040} | 243,6 | 300 | 12.000 | 7.200 | 16 | 50.800 |
| 240 ⁰ _{-0,030} | 190 | 110 | 370 ⁰ _{-0,040} | 263,6 | 325 | 14.250 | 8.550 | 15 | 64.000 |
| 260 ⁰ _{-0,035} | 205 | 120 | 400 ⁰ _{-0,040} | 283,6 | 350 | 16.750 | 10.050 | 15 | 81.800 |
| 280 ⁰ _{-0,035} | 210 | 120 | 430 ⁰ _{-0,045} | 310,6 | 375 | 18.000 | 10.800 | 15 | 96.500 |

In spherical plain bearings up to size 110, the hardened shell is split unilaterally due to assembly reasons. Starting with size 120, the spherical plain bearing consists of two hardened shells secured with a clamp and screw.

Materials:

Outer ring: Bearing steel 100Cr6, hardened and phosphated, with FLUROGLIDE bonded to the inner surface

Inner ring: Bearing steel 100Cr6, hardened, ground, polished, hard chrome plated

On request available in stainless steel

Please note that the numbers pointed off on the pages 17 to 23 and 25 in the data sheets, signalise a thousands place. And the numbers with thousands separators (comma) signalise a decimal point.

Spherical Plain Bearings Series C

**Series GE...CW
GE...CW-2RS**

Spherical plain bearings series C.
DIN ISO 12240-1,
mating surface hard chrome/FLUROGLIDE,
maintenance free

For use with high unidirectionally/variably acting loads

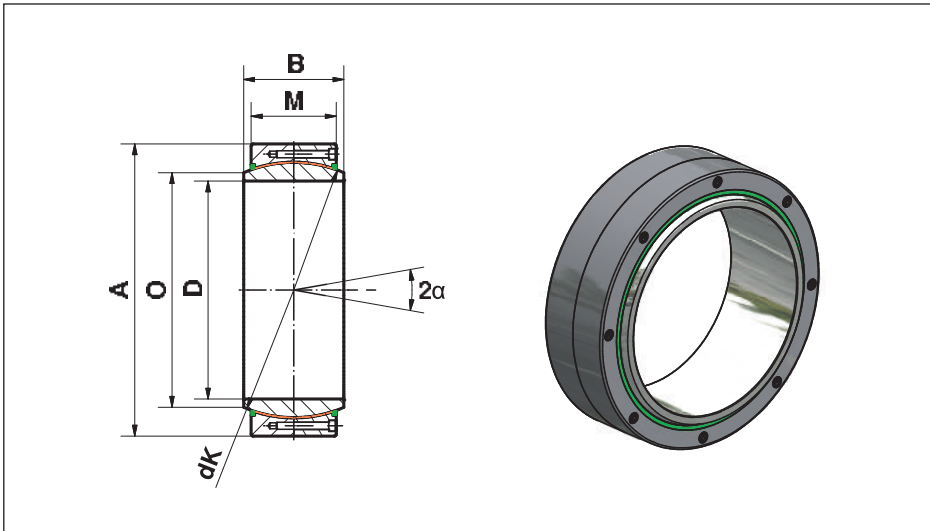

| Series GE...CW | Size (D) | B | M | A | O | dK | Static load ratings C ₀ kN | Dynamic load ratings C kN | Tilting angle α | Weight kg |
|------------------------------------|------------------------------------|-----------------------------------|------------------------------------|------------------------------------|-------|--------|---------------------------------------|---------------------------|-----------------|-----------|
| | 320 ⁰ _{-0,040} | 160 | 135 ⁰ _{-0,90} | 440 ⁰ _{-0,045} | 344,6 | 380 | 25.480 | 15.290 | 4,0 | 76,0 |
| 340 ⁰ _{-0,040} | 160 | 135 ⁰ _{-0,90} | 460 ⁰ _{-0,045} | 366,6 | 400 | 26.830 | 16.095 | 3,8 | 80,0 | |
| 360 ⁰ _{-0,040} | 160 | 135 ⁰ _{-0,90} | 480 ⁰ _{-0,045} | 388,3 | 420 | 28.170 | 16.900 | 3,6 | 86,0 | |
| 380 ⁰ _{-0,040} | 190 | 160 ⁰ _{-1,0} | 520 ⁰ _{-0,050} | 407,9 | 450 | 35.795 | 21.475 | 4,1 | 124,5 | |
| 400 ⁰ _{-0,040} | 190 | 160 ⁰ _{-1,0} | 540 ⁰ _{-0,050} | 429,8 | 470 | 37.385 | 22.430 | 3,9 | 131,0 | |

| Series GE...CW-2RS | Size (D) | B | M | A | O | dK | Static load ratings C ₀ kN | Dynamic load ratings C kN | Tilting angle α | Weight kg |
|------------------------------------|------------------------------------|-----------------------------------|------------------------------------|------------------------------------|-------|--------|---------------------------------------|---------------------------|-----------------|-----------|
| | 320 ⁰ _{-0,040} | 160 | 135 ⁰ _{-0,90} | 440 ⁰ _{-0,045} | 344,6 | 380 | 21.420 | 12.850 | 4,0 | 76,0 |
| 340 ⁰ _{-0,040} | 160 | 135 ⁰ _{-0,90} | 460 ⁰ _{-0,045} | 366,6 | 400 | 22.550 | 13.530 | 3,8 | 80,0 | |
| 360 ⁰ _{-0,040} | 160 | 135 ⁰ _{-0,90} | 480 ⁰ _{-0,045} | 388,3 | 420 | 23.675 | 14.205 | 3,6 | 86,0 | |
| 380 ⁰ _{-0,040} | 190 | 160 ⁰ _{-1,0} | 520 ⁰ _{-0,050} | 407,9 | 450 | 30.980 | 18.590 | 4,1 | 124,5 | |
| 400 ⁰ _{-0,040} | 190 | 160 ⁰ _{-1,0} | 540 ⁰ _{-0,050} | 429,8 | 470 | 32.370 | 19.415 | 3,9 | 131,0 | |

⚠ Please note: The screw design is dimensioned only for the dynamic load rating C!
In case of higher loads, the outer ring halves must be secured by constructional measures (e.g. clamshell cover).

- Materials:**
- Outer ring:** Quenched and tempered steel, with FLUROGLIDE bonded to the inner surface
 - Inner ring:** Bearing steel 100CrMn6, hardened, ground, polished, hard chrome plated

Please note that the numbers pointed off on the pages 17 to 23 and 25 in the data sheets, signalise a thousands place. And the numbers with thousands separators (comma) signalise a decimal point.

Rod Ends Series E

Series EI...EW-2RS

Rod end series E with female thread made of heat-treated steel, galvanized, with EW spherical plain bearing

For use with high, unidirectionally/variably acting loads and low installation width

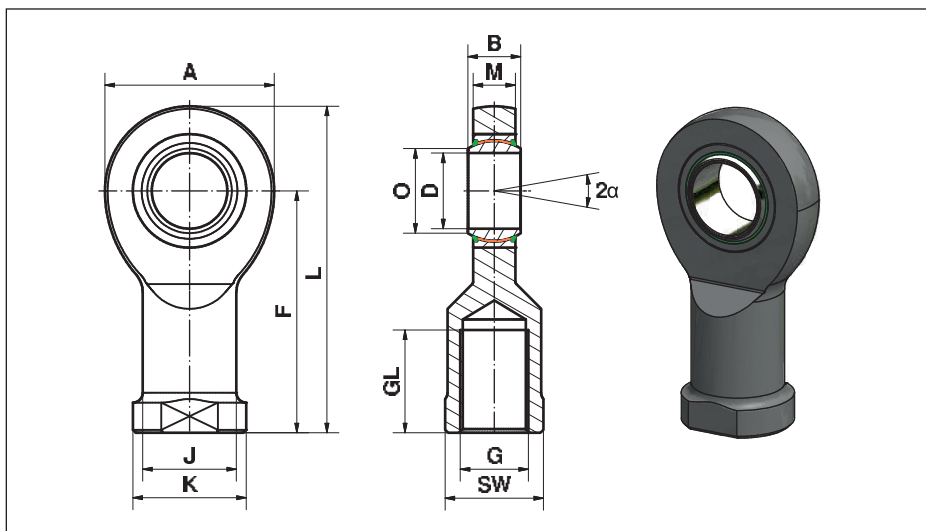

| Size (D) | B | M | A | F | L | K | J | O | SW | G | GL | Static load ratings C ₀ kN | Dynamic load ratings C kN | Tilting angle α | Weight g |
|----------|----|----|-----|-----|-------|-----|------|------|-----|---------|----|---------------------------------------|---------------------------|-----------------|----------|
| 17 | 14 | 11 | 46 | 67 | 90,0 | 30 | 24,0 | 20,7 | 27 | M16 | 33 | 54,5 | 48,7 | 10 | 220 |
| 20 | 16 | 13 | 53 | 77 | 103,5 | 35 | 27,5 | 24,2 | 32 | M20x1,5 | 40 | 62,5 | 67,5 | 9 | 350 |
| 25 | 20 | 17 | 64 | 94 | 126,0 | 42 | 33,5 | 29,3 | 36 | M24x2 | 48 | 92,0 | 127,0 | 7 | 640 |
| 30 | 22 | 19 | 73 | 110 | 146,5 | 50 | 40,0 | 34,2 | 41 | M30x2 | 56 | 124,0 | 165,0 | 6 | 930 |
| 35 | 25 | 21 | 82 | 125 | 166,0 | 58 | 47,0 | 39,8 | 50 | M36x3 | 60 | 144,0 | 210,0 | 6 | 1.300 |
| 40 | 28 | 23 | 92 | 142 | 188,0 | 65 | 52,0 | 45,0 | 55 | M39x3 | 65 | 178,0 | 277,0 | 7 | 2.000 |
| 45 | 32 | 27 | 102 | 145 | 196,0 | 70 | 58,0 | 50,8 | 60 | M42x3 | 65 | 263,0 | 360,0 | 7 | 2.500 |
| 50 | 35 | 30 | 112 | 160 | 216,0 | 75 | 62,0 | 56,0 | 65 | M45x3 | 68 | 320,0 | 442,0 | 6 | 3.500 |
| 60 | 44 | 38 | 135 | 175 | 242,5 | 88 | 70,0 | 66,8 | 75 | M52x3 | 70 | 497,0 | 690,0 | 6 | 5.550 |
| 70 | 49 | 42 | 160 | 200 | 280,0 | 98 | 80,0 | 77,9 | 85 | M56x4 | 80 | 606,0 | 885,0 | 6 | 8.600 |
| 80 | 55 | 47 | 180 | 230 | 320,0 | 110 | 95,0 | 89,4 | 100 | M64x4 | 85 | 752,0 | 1.125,0 | 6 | 12.000 |

⚠ Please note: For rod ends with FLUROGLIDE, the dynamic load rating of the bearing is higher than the static load capacity C₀ of the rod end!

Materials:

Housing: Heat-treated steel to C45, forged, galvanized

Bearing: Maintenance free spherical plain bearing with sealing GE...EW-2RS (see page 17)

Please note that the numbers pointed off on the pages 17 to 23 and 25 in the data sheets, signalise a thousands place. And the numbers with thousands separators (comma) signalise a decimal point.

Rod Ends Series E

Series EA...EW-2RS

Rod end series E with male thread made of heat-treated steel, galvanized, with EW spherical plain bearing

For use with high, unidirectionally/variably acting loads and low installation width

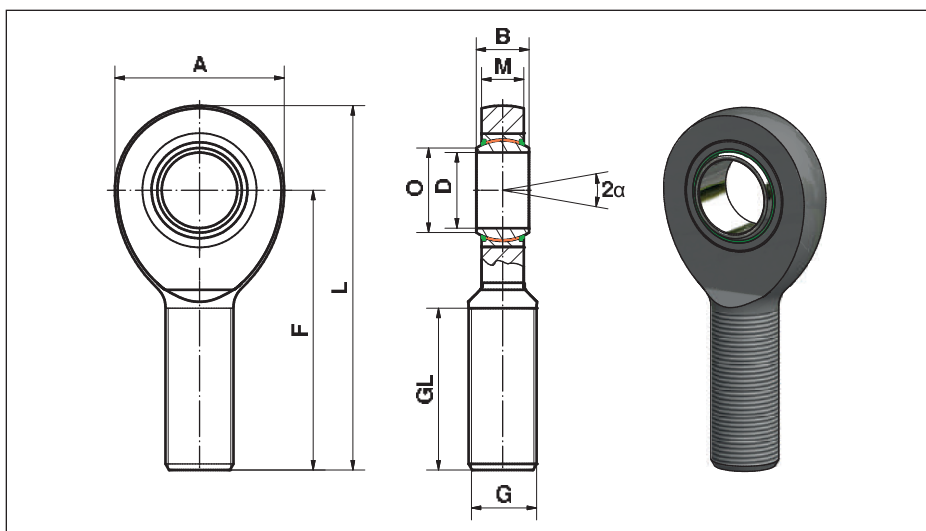

| Size (D) | B | M | A | F | L | O | G | GL | Static load ratings C ₀ kN | Dynamic load ratings C kN | Tilting angle α | Weight g |
|----------|----|----|-----|-----|-------|------|---------|-----|---------------------------------------|---------------------------|-----------------|----------|
| 17 | 14 | 11 | 46 | 69 | 92,0 | 20,7 | M16 | 36 | 54,0 | 48,7 | 10 | 190 |
| 20 | 16 | 13 | 53 | 78 | 104,5 | 24,1 | M20x1,5 | 43 | 62,5 | 67,5 | 9 | 320 |
| 25 | 20 | 17 | 64 | 94 | 126,0 | 29,3 | M24x2 | 53 | 92,0 | 127,0 | 7 | 560 |
| 30 | 22 | 19 | 73 | 110 | 146,5 | 34,2 | M30x2 | 65 | 124,0 | 165,0 | 6 | 890 |
| 35 | 25 | 21 | 82 | 140 | 181,0 | 39,7 | M36x3 | 82 | 144,0 | 210,0 | 6 | 1.400 |
| 40 | 28 | 23 | 92 | 150 | 196,0 | 45,0 | M39x3 | 86 | 178,0 | 277,0 | 7 | 1.800 |
| 45 | 32 | 27 | 102 | 163 | 214,0 | 50,7 | M42x3 | 94 | 263,0 | 360,0 | 7 | 2.610 |
| 50 | 35 | 30 | 112 | 185 | 241,0 | 55,9 | M45x3 | 107 | 320,0 | 442,0 | 6 | 3.450 |
| 60 | 44 | 38 | 135 | 210 | 277,5 | 66,8 | M52x3 | 115 | 497,0 | 690,0 | 6 | 5.900 |
| 70 | 49 | 42 | 160 | 235 | 315,0 | 77,8 | M56x4 | 125 | 566,0 | 885,0 | 6 | 8.200 |
| 80 | 55 | 47 | 180 | 270 | 360,0 | 89,4 | M64x4 | 140 | 752,0 | 1.125,0 | 6 | 12.000 |

⚠ Please note: For rod ends with FLUROGLIDE, the dynamic load rating of the bearing is higher than the static load capacity C₀ of the rod end!

Materials:

Housing: Heat-treated steel to C45, forged, galvanized

Bearing: Maintenance free spherical plain bearing with sealing GE...EW -2RS (see page 17)

Please note that the numbers pointed off on the pages 17 to 23 and 25 in the data sheets, signalise a thousands place. And the numbers with thousands separators (comma) signalise a decimal point.

Angular Spherical Plain Bearing

Series GE...SWE

Angular spherical plain bearing, mating surface hard chrome/
FLUROGLIDE,
maintenance free

For use with high radial load in combination with axial load

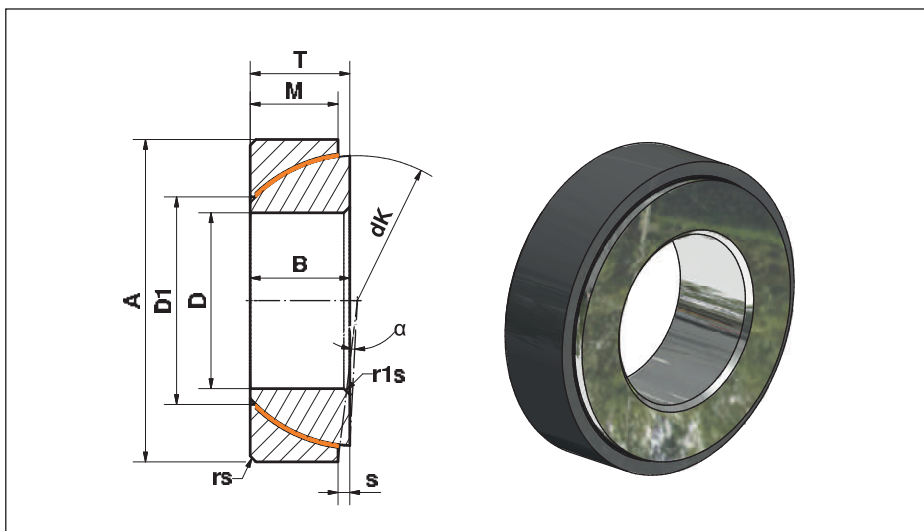

| Size (D) | D1 | B | M | A | T | S | rs, r1s min | dk | Radial load rating kN | | Tilting angle α ≈ | Weight g |
|------------------------------------|-------|----|------|------------------------------------|--------------------------------------|------|-------------|-------|-----------------------|-----------|-------------------|----------|
| | | | | | | | | | Static Co | Dynamic C | | |
| 25 ⁰ _{-0.012} | 31,8 | 15 | 14,0 | 47 ⁰ _{-0.014} | 15 ^{+0.25} _{-0.40} | 0,6 | 1,0 | 42,0 | 235 | 141 | 2,5 | 148 |
| 28 ⁰ _{-0.012} | 35,8 | 15 | 15,0 | 52 ⁰ _{-0.016} | 16 ^{+0.25} _{-0.40} | 1,0 | 1,0 | 47,0 | 287 | 171 | 2,0 | 186 |
| 30 ⁰ _{-0.012} | 36,8 | 17 | 15,0 | 55 ⁰ _{-0.016} | 17 ^{+0.25} _{-0.40} | 1,3 | 1,0 | 49,5 | 298 | 179 | 4,5 | 208 |
| 35 ⁰ _{-0.012} | 42,7 | 18 | 16,0 | 62 ⁰ _{-0.016} | 18 ^{+0.25} _{-0.40} | 2,1 | 1,0 | 55,5 | 345 | 207 | 4,0 | 268 |
| 40 ⁰ _{-0.012} | 47,7 | 19 | 17,0 | 68 ⁰ _{-0.016} | 19 ^{+0.25} _{-0.40} | 2,8 | 1,0 | 62,0 | 424 | 254 | 3,5 | 327 |
| 45 ⁰ _{-0.012} | 53,7 | 20 | 18,0 | 75 ⁰ _{-0.016} | 20 ^{+0.25} _{-0.40} | 3,5 | 1,0 | 68,5 | 494 | 296 | 3,0 | 416 |
| 50 ⁰ _{-0.012} | 59,7 | 20 | 19,0 | 80 ⁰ _{-0.016} | 20 ^{+0.25} _{-0.40} | 4,3 | 1,0 | 74,0 | 567 | 340 | 1,5 | 455 |
| 55 ⁰ _{-0.015} | 62,7 | 23 | 20,0 | 90 ⁰ _{-0.018} | 23 ^{+0.25} _{-0.50} | 5,0 | 1,0 | 82,0 | 681 | 408 | 4,0 | 645 |
| 60 ⁰ _{-0.015} | 70,0 | 23 | 21,0 | 95 ⁰ _{-0.018} | 23 ^{+0.25} _{-0.50} | 5,7 | 1,1 | 88,5 | 784 | 470 | 2,5 | 714 |
| 65 ⁰ _{-0.015} | 76,6 | 23 | 22,0 | 100 ⁰ _{-0.018} | 23 ^{+0.25} _{-0.50} | 6,5 | 1,1 | 93,5 | 836 | 502 | 1,0 | 759 |
| 70 ⁰ _{-0.015} | 82,6 | 25 | 23,0 | 110 ⁰ _{-0.018} | 25 ^{+0.25} _{-0.50} | 7,2 | 1,1 | 102,0 | 972 | 583 | 2,0 | 1.040 |
| 80 ⁰ _{-0.015} | 91,6 | 29 | 25,5 | 125 ⁰ _{-0.020} | 29 ^{+0.25} _{-0.50} | 8,6 | 1,1 | 115,0 | 1.184 | 711 | 3,5 | 1.540 |
| 90 ⁰ _{-0.020} | 100,9 | 32 | 28,0 | 140 ⁰ _{-0.020} | 32 ^{+0.25} _{-0.60} | 10,1 | 1,5 | 128,5 | 1.490 | 894 | 3,5 | 2.090 |
| 100 ⁰ _{-0.020} | 114,6 | 32 | 31,0 | 150 ⁰ _{-0.020} | 32 ^{+0.25} _{-0.60} | 11,6 | 1,5 | 141,0 | 1.848 | 1.109 | 0,5 | 2.340 |
| 110 ⁰ _{-0.020} | 126,5 | 38 | 34,0 | 170 ⁰ _{-0.020} | 38 ^{+0.25} _{-0.60} | 13,0 | 2,0 | 155,0 | 1.967 | 1.180 | 3,0 | 3.680 |
| 120 ⁰ _{-0.020} | 136,5 | 38 | 37,0 | 180 ⁰ _{-0.025} | 38 ^{+0.25} _{-0.60} | 14,5 | 2,0 | 168,0 | 2.585 | 1.551 | 0,5 | 3.970 |
| 130 ⁰ _{-0.020} | 144,0 | 45 | 43,0 | 200 ⁰ _{-0.025} | 45 ^{+0.35} _{-0.70} | 18,0 | 2,5 | 188,0 | 3.412 | 2.047 | 1,0 | 5.920 |
| 140 ⁰ _{-0.020} | 161,5 | 45 | 43,0 | 210 ⁰ _{-0.025} | 45 ^{+0.35} _{-0.70} | 19,0 | 2,5 | 198,0 | 3.286 | 1.972 | 1,0 | 6.330 |
| 150 ⁰ _{-0.025} | 171,4 | 48 | 46,0 | 225 ⁰ _{-0.030} | 48 ^{+0.35} _{-0.70} | 20,0 | 3,0 | 211,0 | 3.814 | 2.288 | 1,0 | 8.010 |
| 160 ⁰ _{-0.025} | 182,4 | 51 | 49,0 | 240 ⁰ _{-0.030} | 51 ^{+0.35} _{-0.70} | 20,0 | 3,0 | 225,0 | 4.524 | 2.714 | 1,0 | 9.790 |
| 170 ⁰ _{-0.025} | 194,4 | 57 | 55,0 | 260 ⁰ _{-0.035} | 57 ^{+0.35} _{-0.70} | 21,0 | 3,0 | 246,0 | 5.872 | 3.523 | 1,0 | 12.300 |
| 180 ⁰ _{-0.025} | 206,4 | 64 | 61,0 | 280 ⁰ _{-0.035} | 64 ^{+0.35} _{-0.70} | 21,0 | 3,0 | 260,0 | 6.536 | 3.922 | 1,0 | 17.400 |
| 190 ⁰ _{-0.030} | 212,5 | 64 | 62,0 | 290 ⁰ _{-0.035} | 64 ^{+0.35} _{-0.80} | 26,0 | 3,0 | 275,0 | 7.352 | 4.410 | 0,5 | 18.200 |
| 200 ⁰ _{-0.030} | 229,4 | 70 | 66,0 | 310 ⁰ _{-0.035} | 70 ^{+0.35} _{-0.80} | 26,0 | 3,0 | 290,0 | 7.725 | 4.635 | 1,5 | 23.800 |

Materials:

Housing disk: Bearing steel 100Cr6, hardened and phosphated, with FLUROGLIDE bonded to the inner surface

Inner disk: Bearing steel 100Cr6, hardened, ground, polished, hard chrome plated

On request available in stainless steel

Please note that the numbers pointed off on the pages 17 to 23 and 25 in the data sheets, signalise a thousands place. And the numbers with thousands separators (comma) signalise a decimal point.

FLURO-Gelenklager GmbH

Axial Spherical Plain Bearing

Series GE...AWE

Axial spherical plain bearing, mating surface hard chrome/ FLUROGLIDE, maintenance free

For use with high axial loads

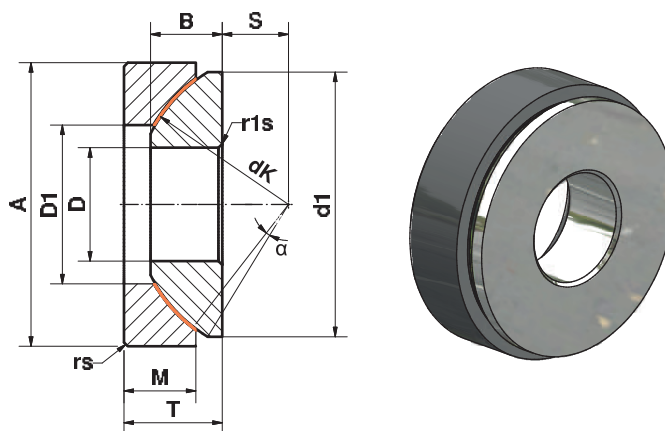

| Size (D) | B | M | A | T | S | r _s , r _{1s} min | d ₁ min | D1 | d _k | Axial load rating kN | | Tilting angle α ≈ | Weight g |
|------------------------------------|-------|------|------------------------------------|---|------|--------------------------------------|--------------------|-------|----------------|-----------------------|-----------|-------------------|----------|
| | | | | | | | | | | Static C ₀ | Dynamic C | | |
| 10 ⁰ _{-0.008} | 7,5 | 7,0 | 30 ⁰ _{-0.009} | 9,5 ^{+0.25} _{-0.40} | 7,0 | 0,6 | 27,5 | 17,0 | 32 | 146 | 88 | 5,0 | 36 |
| 12 ⁰ _{-0.008} | 9,5 | 9,3 | 35 ⁰ _{-0.011} | 13,0 ^{+0.25} _{-0.40} | 8,0 | 0,6 | 32,0 | 20,0 | 38 | 195 | 117 | 5,0 | 72 |
| 15 ⁰ _{-0.008} | 11 | 10,8 | 42 ⁰ _{-0.011} | 15,0 ^{+0.25} _{-0.40} | 10,0 | 0,6 | 39,0 | 24,5 | 46 | 278 | 167 | 6,0 | 108 |
| 17 ⁰ _{-0.008} | 11,8 | 11,2 | 47 ⁰ _{-0.011} | 16,0 ^{+0.25} _{-0.40} | 11,0 | 0,6 | 43,5 | 28,5 | 52 | 350 | 210 | 4,0 | 137 |
| 20 ⁰ _{-0.010} | 14,5 | 13,8 | 55 ⁰ _{-0.013} | 20,0 ^{+0.25} _{-0.40} | 12,5 | 1,0 | 50,0 | 34,0 | 60 | 410 | 246 | 5,0 | 246 |
| 25 ⁰ _{-0.010} | 16,5 | 16,7 | 62 ⁰ _{-0.013} | 22,5 ^{+0.25} _{-0.40} | 14,0 | 1,0 | 58,5 | 35,0 | 68 | 718 | 431 | 5,0 | 415 |
| 30 ⁰ _{-0.010} | 19,0 | 19,0 | 75 ⁰ _{-0.013} | 26,0 ^{+0.25} _{-0.40} | 17,5 | 1,0 | 70,0 | 44,5 | 82 | 920 | 552 | 5,0 | 614 |
| 35 ⁰ _{-0.012} | 22,0 | 20,7 | 90 ⁰ _{-0.015} | 28,0 ^{+0.25} _{-0.40} | 22,0 | 1,0 | 84,0 | 52,5 | 98 | 1.340 | 804 | 5,0 | 973 |
| 40 ⁰ _{-0.012} | 27,0 | 21,5 | 105 ⁰ _{-0.015} | 32,0 ^{+0.25} _{-0.40} | 24,5 | 1,0 | 97,0 | 59,5 | 114 | 1.789 | 1.073 | 6,0 | 1.590 |
| 45 ⁰ _{-0.012} | 31,0 | 25,5 | 120 ⁰ _{-0.015} | 36,5 ^{+0.25} _{-0.40} | 27,5 | 1,0 | 110,0 | 68,5 | 128 | 2.263 | 1.357 | 6,0 | 2.240 |
| 50 ⁰ _{-0.012} | 33,0 | 30,5 | 130 ⁰ _{-0.018} | 42,5 ^{+0.25} _{-0.40} | 30,0 | 1,0 | 120,0 | 71,0 | 139 | 2.836 | 1.702 | 6,0 | 3.140 |
| 60 ⁰ _{-0.015} | 37,0 | 34,0 | 150 ⁰ _{-0.018} | 45,0 ^{+0.25} _{-0.50} | 35,0 | 1,0 | 140,0 | 86,5 | 160 | 3.790 | 2.274 | 6,0 | 4.630 |
| 70 ⁰ _{-0.015} | 42,0 | 36,5 | 160 ⁰ _{-0.025} | 50,0 ^{+0.25} _{-0.50} | 35,0 | 1,0 | 153,0 | 95,5 | 176 | 4.887 | 2.932 | 3,0 | 5.370 |
| 80 ⁰ _{-0.015} | 43,5 | 38,0 | 180 ⁰ _{-0.025} | 50,0 ^{+0.25} _{-0.50} | 42,5 | 1,0 | 172,0 | 109,0 | 197 | 5.908 | 3.545 | 4,0 | 6.910 |
| 100 ⁰ _{-0.020} | 51,0 | 46,0 | 210 ⁰ _{-0.030} | 59,0 ^{+0.25} _{-0.60} | 45,0 | 1,1 | 198,0 | 134,0 | 222 | 7.018 | 4.210 | 4,0 | 11.000 |
| 120 ⁰ _{-0.020} | 53,5 | 50 | 230 ⁰ _{-0.030} | 64,0 ^{+0.25} _{-0.60} | 52,5 | 1,1 | 220,0 | 155,0 | 250 | 8.162 | 4.897 | 3,0 | 14.000 |
| 140 ⁰ _{-0.025} | 61,0 | 54,0 | 260 ⁰ _{-0.035} | 72,0 ^{+0.35} _{-0.70} | 52,5 | 1,5 | 243,0 | 177,0 | 274 | 9.372 | 5.623 | 3,0 | 19.100 |
| 160 ⁰ _{-0.025} | 66,0 | 58,0 | 290 ⁰ _{-0.035} | 77,0 ^{+0.35} _{-0.70} | 65,0 | 1,5 | 271,0 | 200,0 | 313 | 11.680 | 7.008 | 2,0 | 25.000 |
| 180 ⁰ _{-0.025} | 74,0 | 62,0 | 320 ⁰ _{-0.040} | 86,0 ^{+0.35} _{-0.70} | 67,5 | 1,5 | 299,0 | 225,0 | 340 | 12.364 | 7.418 | 4,0 | 32.800 |
| 200 ⁰ _{-0.030} | 80,0 | 66,0 | 340 ⁰ _{-0.040} | 87,0 ^{+0.35} _{-0.80} | 70,0 | 1,5 | 320,0 | 247,0 | 365 | 15.350 | 9.210 | 1,0 | 35.400 |
| 220 ⁰ _{-0.030} | 82,0 | 67,0 | 370 ⁰ _{-0.040} | 97,0 ^{+0.35} _{-0.80} | 75,0 | 1,5 | 350,0 | 265,5 | 388 | 14.119 | 8.471 | 7,0 | 44.700 |
| 240 ⁰ _{-0.030} | 87,0 | 73,0 | 400 ⁰ _{-0.040} | 103,0 ^{+0.35} _{-0.80} | 77,5 | 1,5 | 382,0 | 294,0 | 420 | 17.176 | 10.305 | 6,0 | 56.900 |
| 260 ⁰ _{-0.035} | 95,0 | 80,0 | 430 ⁰ _{-0.045} | 115,0 ^{+0.35} _{-0.80} | 82,5 | 1,5 | 409,0 | 317,0 | 449 | 18.019 | 10.811 | 7,0 | 71.300 |
| 280 ⁰ _{-0.035} | 100,0 | 85,0 | 460 ⁰ _{-0.045} | 110,0 ^{+0.35} _{-0.80} | 80,0 | 3,0 | 445,0 | 337,0 | 480 | 28.561 | 17.136 | 4,0 | 84.700 |
| 300 ⁰ _{-0.035} | 100,0 | 90,0 | 480 ⁰ _{-0.045} | 110,0 ^{+0.35} _{-0.80} | 80,0 | 3,0 | 460,0 | 356,0 | 490 | 28.809 | 17.285 | 3,5 | 88.900 |

Materials:

Housing disk: Bearing steel 100Cr6, hardened and phosphated, with FLUROGLIDE bonded to the inner surface

Inner disk: Bearing steel 100Cr6, hardened, ground, polished, hard chrome plated

On request available in stainless steel

Please note that the numbers pointed off on the pages 17 to 23 and 25 in the data sheets, signalise a thousands place. And the numbers with thousands separators (comma) signalise a decimal point.

Cylindrical Sliding Bushings

According to DIN ISO 4379¹ cylindrical sliding bushings are standardized, ready-to-fit machine parts. They consist of a backing with cylindrical outer and inner surface to support the sliding layer.

They can absorb higher forces than conventional steel, bronze, or plastic slide bearings and are ideal for pivoting movements and high, unidirectional and variable loads.

Used as **axial** guide bearings, they are also superior to the already mentioned slide bearings.

! Please note: The linear stroke of the shaft in the sliding bushing may not exceed **2.5 x dimensions B** or the service life will be significantly reduced.

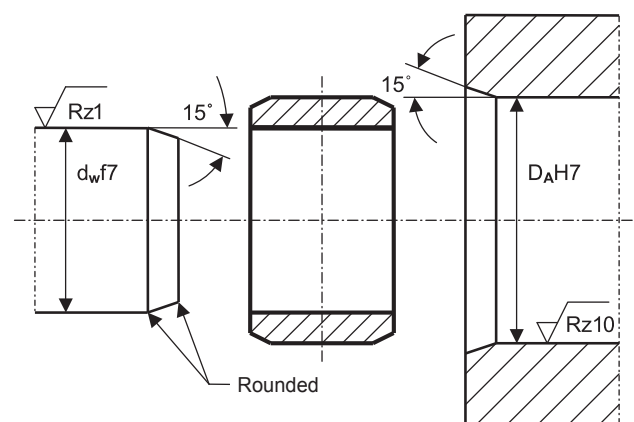

Series

Sliding bushings are manufactured as GB... X... X... ZW in the range $d = 30-200$. The unhardened steel backing/outer ring is mechanically machined accordingly and the sliding layer is applied to the bore. The counter mate (shaft/bolt) is missing and is usually provided by the customer.

The counter mate should have a surface hardness of $HR_c \geq 55$ and a roughness of $R_z \leq 1$.

Precision

The main dimensions acc. to DIN ISO 286-2 are tolerated as follows:

Bore diameter $d = H8$,
 Outside diameter $D = p7$,
 Width $W = h12$.

The shape and position tolerances are within the specifications listed above.

If the sliding bushings GB... x... x... ZW are installed in a housing bore H7 and the shaft/the bolt is manufactured in f7, the resulting operating clearance is in the following ranges (see Table 4):

| | | | |
|------------------------------|---------------------------------------|--|---|
| Operating clearance = | $d > 30 - 80$ 0.030 - 0.080 | $d > 80 - 120$ 0.060 - 0.090 | $d > 120 - 200$ 0.060 - 0.100 |
|------------------------------|---------------------------------------|--|---|

Table 4: Sliding bushing operating clearance

¹ Applies to dimensions d , D and B

Cylindrical Sliding Bushings

Series GB..x..x..ZW

Cylindrical sliding bushings,
DIN ISO 4379

Lined with
FLUROGLIDE

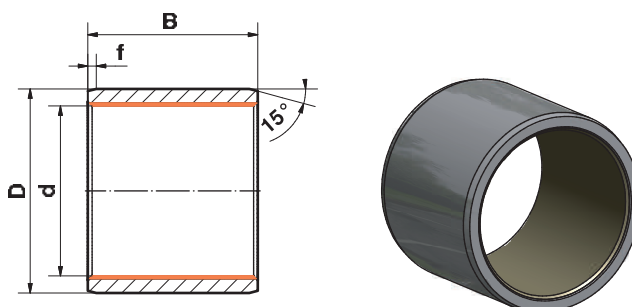

| Nominal diameter (d) | Code | Weight g | D (p7) | B | f | Static / Dynamic Load rating kN |
|--------------------------------------|-----------------------|----------|---|--------------------------------------|----------|---------------------------------|
| 30 ^{+0,033} / ₀ | GB 30 x 36 x 30 ZW | 63 | 36 ^{+0,051} / _{+0,026} | 30 ⁰ / _{-0,021} | 1,5 ±0,5 | 270 |
| 35 ^{+0,039} / ₀ | GB 35 x 41 x 30 ZW | 72 | 41 ^{+0,051} / _{+0,026} | 30 ⁰ / _{-0,021} | 1,5 ±0,5 | 315 |
| 40 ^{+0,039} / ₀ | GB 40 x 48 x 40 ZW | 160 | 48 ^{+0,051} / _{+0,026} | 40 ⁰ / _{-0,025} | 2,0 ±0,7 | 480 |
| 45 ^{+0,039} / ₀ | GB 45 x 53 x 40 ZW | 170 | 53 ^{+0,062} / _{+0,032} | 40 ⁰ / _{-0,025} | 2,0 ±0,7 | 540 |
| 50 ^{+0,039} / ₀ | GB 50 x 58 x 50 ZW | 240 | 58 ^{+0,062} / _{+0,032} | 50 ⁰ / _{-0,025} | 2,0 ±0,7 | 750 |
| 60 ^{+0,046} / ₀ | GB 60 x 70 x 60 ZW | 440 | 70 ^{+0,062} / _{+0,032} | 60 ⁰ / _{-0,030} | 2,0 ±0,7 | 1.080 |
| 70 ^{+0,046} / ₀ | GB 70 x 80 x 70 ZW | 590 | 80 ^{+0,072} / _{+0,037} | 70 ⁰ / _{-0,030} | 3,0 ±1,0 | 1.470 |
| 80 ^{+0,046} / ₀ | GB 80 x 90 x 80 ZW | 750 | 90 ^{+0,072} / _{+0,037} | 80 ⁰ / _{-0,030} | 3,0 ±1,0 | 1.920 |
| 90 ^{+0,054} / ₀ | GB 90 x 105 x 80 ZW | 1.360 | 105 ^{+0,072} / _{+0,037} | 80 ⁰ / _{-0,030} | 3,0 ±1,0 | 2.160 |
| 100 ^{+0,054} / ₀ | GB 100 x 115 x 100 ZW | 1.900 | 115 ^{+0,072} / _{+0,037} | 100 ⁰ / _{-0,035} | 3,0 ±1,0 | 3.000 |
| 110 ^{+0,054} / ₀ | GB 110 x 125 x 100 ZW | 2.000 | 125 ^{+0,083} / _{+0,043} | 100 ⁰ / _{-0,035} | 4,0 ±1,0 | 3.300 |
| 120 ^{+0,054} / ₀ | GB 120 x 135 x 120 ZW | 2.600 | 135 ^{+0,083} / _{+0,043} | 120 ⁰ / _{-0,035} | 4,0 ±1,0 | 4.320 |
| 140 ^{+0,063} / ₀ | GB 140 x 155 x 150 ZW | 3.900 | 155 ^{+0,083} / _{+0,043} | 150 ⁰ / _{-0,040} | 4,0 ±1,0 | 6.300 |
| 160 ^{+0,063} / ₀ | GB 160 x 180 x 150 ZW | 6.000 | 180 ^{+0,083} / _{+0,043} | 150 ⁰ / _{-0,040} | 4,0 ±1,0 | 7.200 |
| 180 ^{+0,063} / ₀ | GB 180 x 200 x 180 ZW | 8.000 | 200 ^{+0,096} / _{+0,050} | 180 ⁰ / _{-0,040} | 5,0 ±1,0 | 9.720 |
| 200 ^{+0,072} / ₀ | GB 200 x 220 x 180 ZW | 8.800 | 220 ^{+0,096} / _{+0,050} | 180 ⁰ / _{-0,040} | 5,0 ±1,0 | 10.820 |

Materials:

Bushing: Bearing steel 100Cr6 with FLUROGLIDE bonded to the inner surface

Bushings sealed on both sides are available upon request

Please note that the numbers pointed off on the pages 17 to 23 and 25 in the data sheets, signalise a thousands place. And the numbers with thousands separators (comma) signalise a decimal point.

Specifications Service Life Calculation Fax +49 (0) 74 28 / 93 85-25

Please fill in

Company: _____
 Contact: _____
 Phone: _____
 Installation site: _____

Environmental conditions

| | | |
|--------------|-----------|---------------------|
| Temperature: | Humidity: | Special conditions: |
|--------------|-----------|---------------------|

Load

| Radial load | Axial load |
|---|------------|
| F_r max | F_a max |
| F_r min | F_a min |
| F_r static | |
| Load direction <input type="checkbox"/> unidirectional <input type="checkbox"/> pulsating <input type="checkbox"/> variable Load frequency _____ (if known) | |

Movements

| | Pivoting | Tilting | Pivoting + Tilting | Rotating |
|------------|------------|-------------|--------------------|------------|
| Angle (°) | $\beta =$ | $\alpha =$ | $\beta_1 =$ | $\beta =$ |
| Time (min) | $t\beta =$ | $t\alpha =$ | $t\beta_1 =$ | $t\beta =$ |

Definition: A pivoting-, tilting-, combination-, or rotating movement comprises 2β or 2α or $2 \times 180^\circ = 360$

Movement Frequency

Number "f" of the pivoting-, tilting-, or rotating movement per second s^{-1} , minute min^{-1} or hour h^{-1}
 Please also indicate in the field the duration of the frequency of the respective angles in h/day, days/weeks and week

| | Pivoting | Tilting | Pivoting + Tilting | Rotating |
|-----------|----------|---------|--------------------|----------|
| Frequency | f = | f = | f = | n = |
| On: | | | | |

Are loading and movement collectives to be expected, please also indicate the duty cycle (DC) as a percentage in DC %.

Requirements for the spherical plain bearing service life

| Oscillations/Pivoting Movements | Hours | Days | Years |
|---------------------------------|---------|---------|---------|
| $L_f =$ | $L_h =$ | $L_T =$ | $L_j =$ |

Please add all other available information to the filled in specifications as best as possible.

Additional comments:



Special Applications



Railway vehicles



Transportation Systems



Loading Cranes



Construction machines



Shear lifting table



Ship building

FLURO-Gelenklager GmbH

FLURO-Gelenklager GmbH



Rosenfeld is situated between the city of Stuttgart and the lake Bodensee, in southern Germany. You can get to us easily from the international airport of Stuttgart by car. Drive Highway A81 south (towards Singen), exit at Oberndorf and follow the road to Rosenfeld. Our company's plant is situated in the midst of an industrial area on the right hand side behind the town's entrance. We invite you to pay a visit at our manufacturing plant to see our capability.

FLURO - Gelenklager GmbH
 Siemensstrasse 13
 D-72348 Rosenfeld
 Phone +49 (0) 74 28 93 85-0
 Fax +49 (0) 74 28 93 85-25
 Internet: www.fluro.de
 E-Mail: info@fluro.de



This is how you can get to us:

