

# data sheet: A1216 - A1219 / A1222 - A1225

Kroepelin GmbH  
Gartenstraße 50  
D-36381 Schlüchtern

Tel.: 06661 86 0  
Fax: 06661 86 39  
Mail: sales@kroepelin.com  
Web: www.kroepelin.com

**Kroepelin**  
Längenmesstechnik

Both applications can be measured by changing the measuring contacts.

## Measurement of H<sub>2</sub>

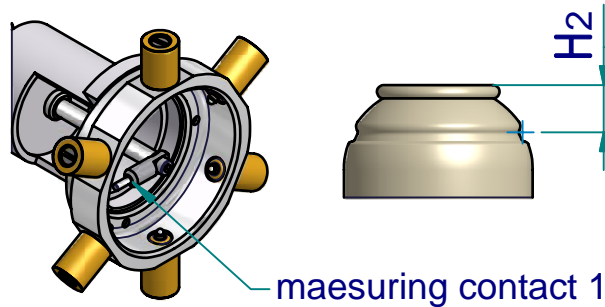

## Measurement of H<sub>Stem</sub>

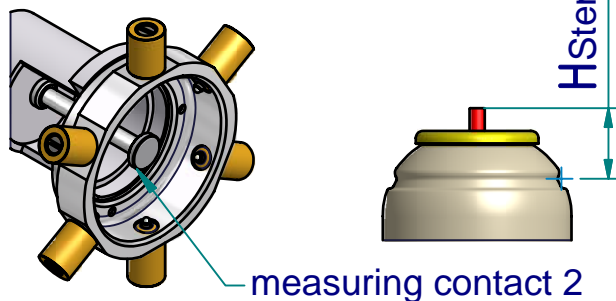

subject to technical alterations

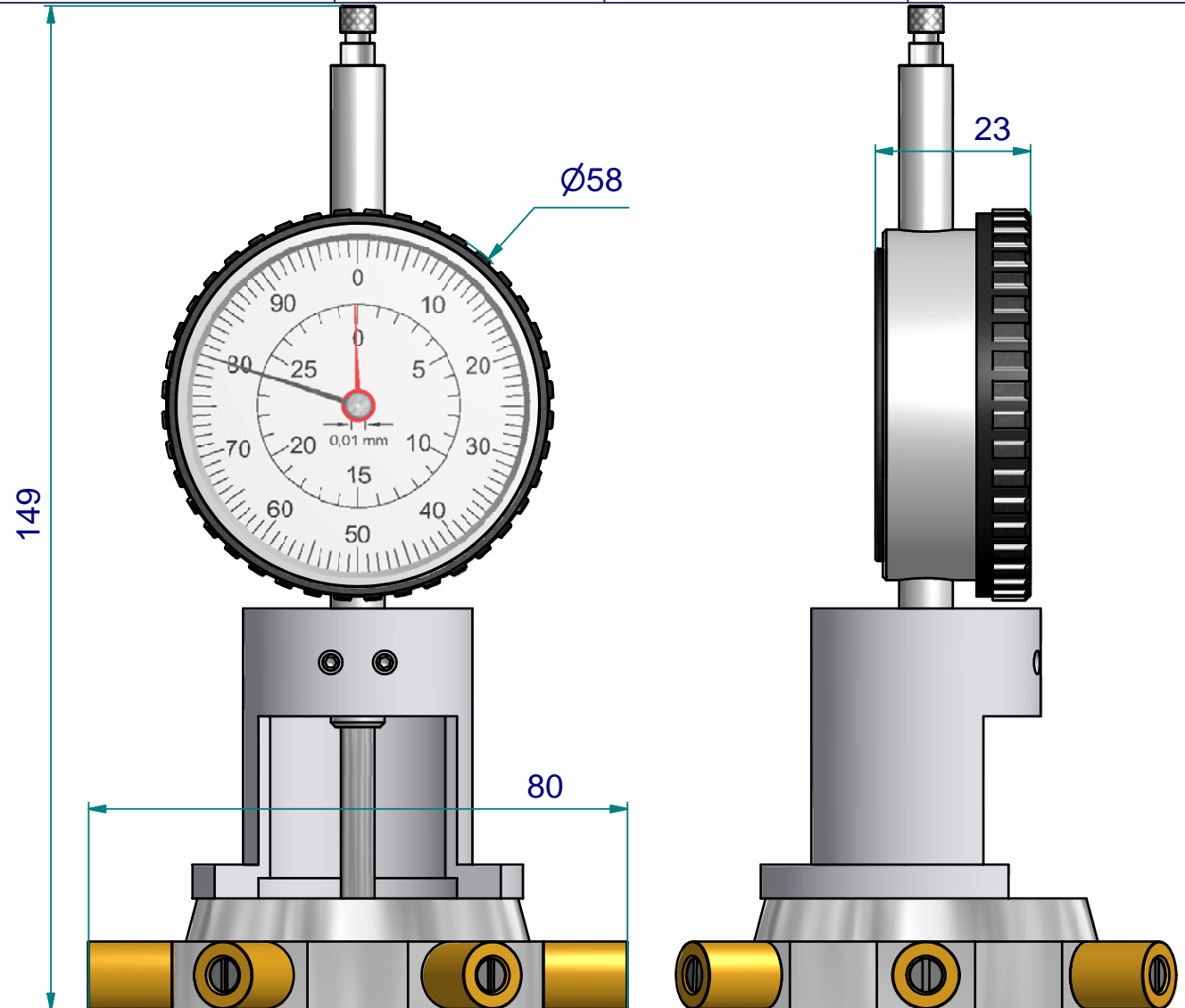

**type:** Aerosol  
**range:** 0-30 mm  
**range of indication:**  
**digital step:**  
**scale interval:** 0,01 mm  
**measuring force:** 0,6 +/- 0,1 N  
**weight:** ca. 700g

acceptable deviations  
VDI/VDE/DGQ 2618 Bl. 12.1/13.1)  
**max. permissible errors "G":** 0,03 mm  
**repeatability "r":** 0,02 mm  
**reference temperature:** 20° C  
**operation temperature:** 10° C - 30° C  
**storage temperature:** -10° C - 50° C

**scale:** 1:1 (1:2)  
**drawing-nr.:** IDW-A1218-DB\_e  
**date of issue:** 23.11.10  
**name:** J.Heuser  
  
**revision status:** 001  
**revision date:** 01.11.10

4

3

2

1

A1216 - A1219 / A1222 - A1225

D

C

B

A

calibration  
H<sub>2</sub>

calibration  
H<sub>Stem</sub>

adjust ring  
(included in delivery)

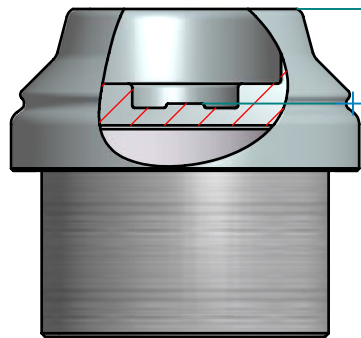

H<sub>2</sub> cal

H<sub>Stem 0</sub>

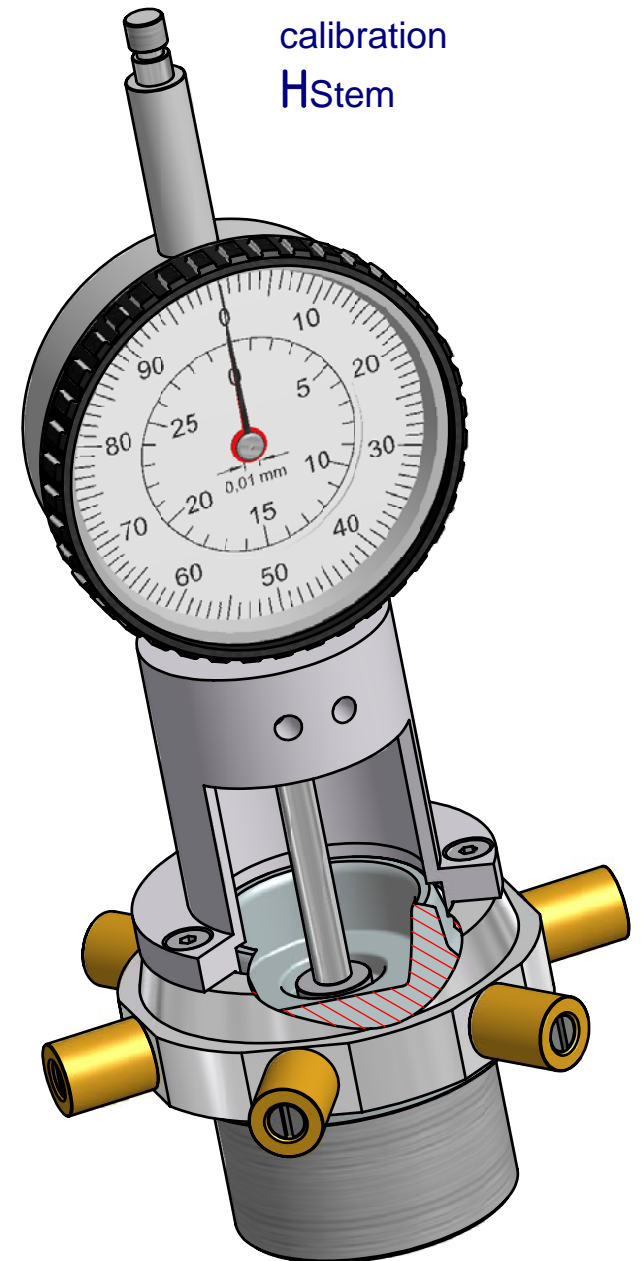
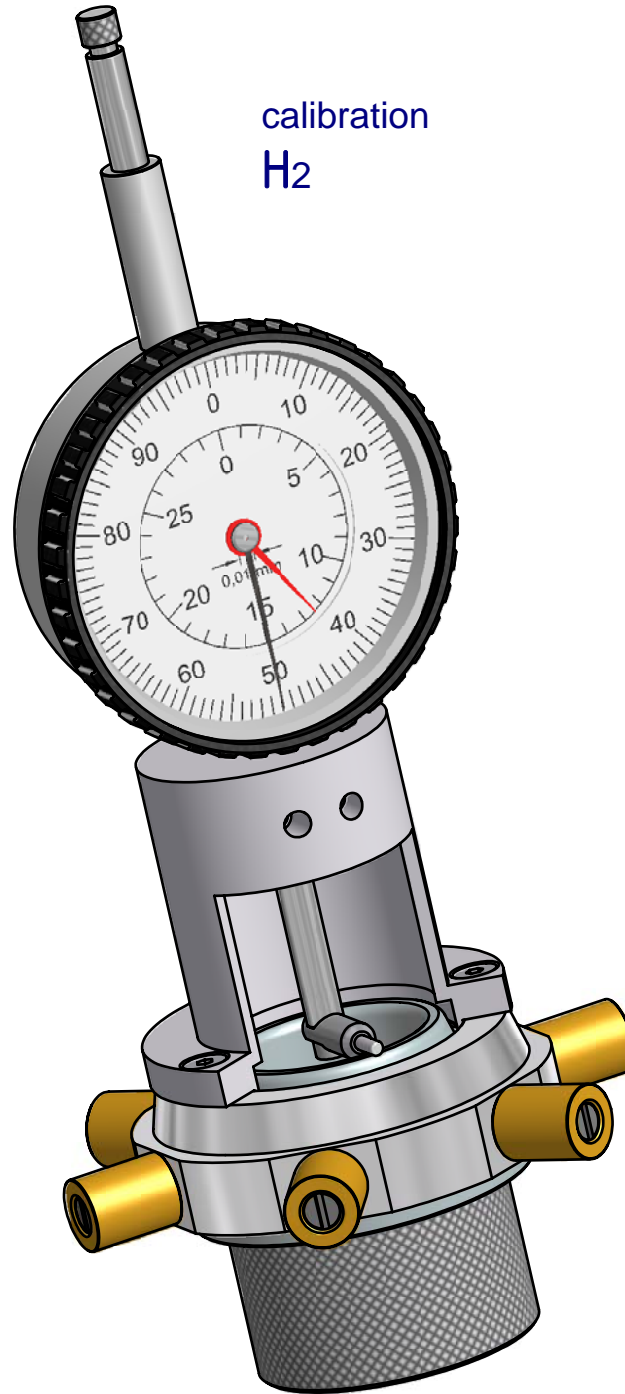

4

3

2

1

A1216 - A1219 / A1222 - A1225

D

measurement  
HStem

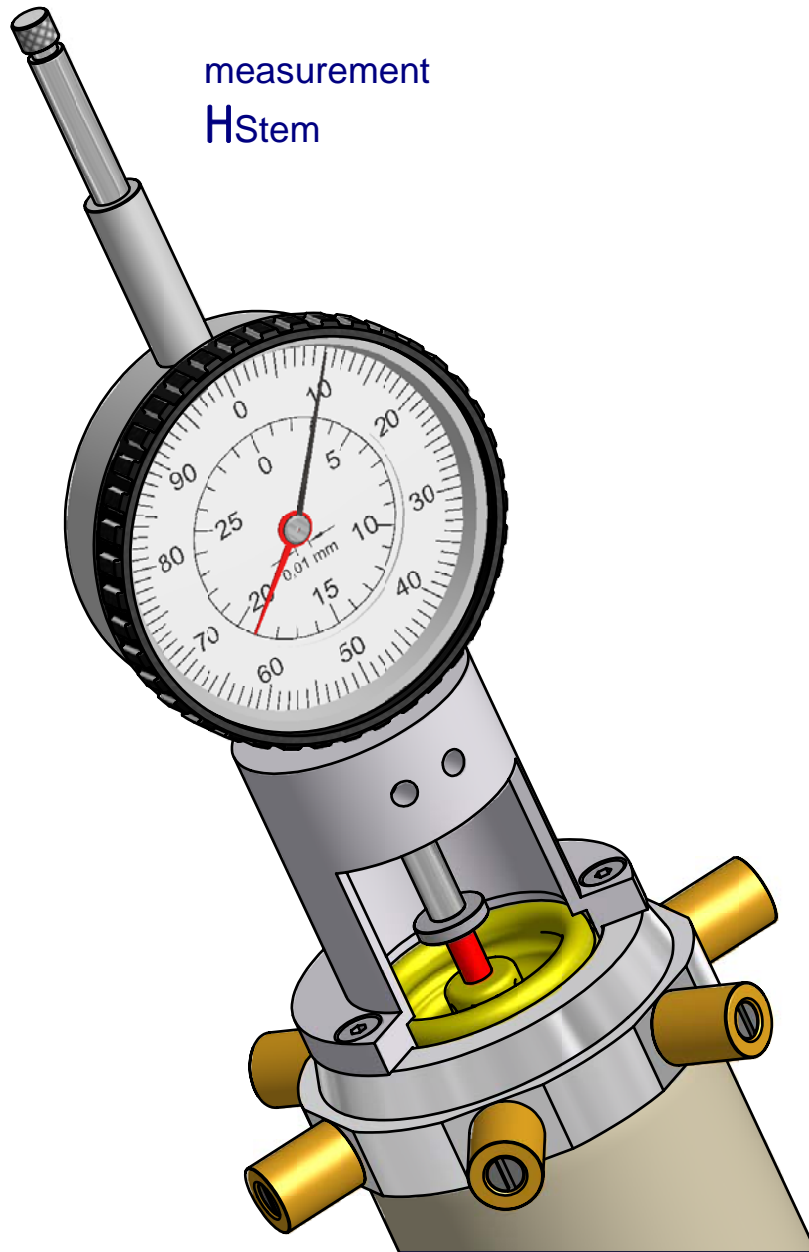

C

measurement  
H<sub>2</sub>

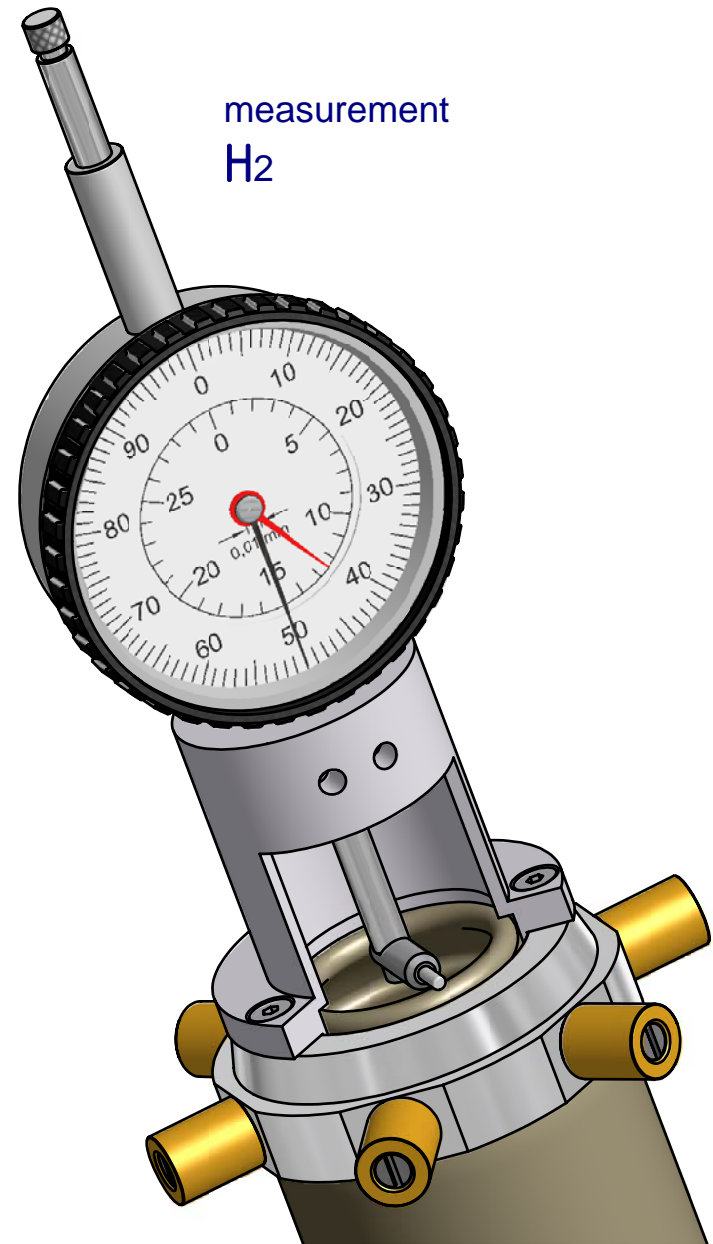

B

A

# A1216 - A1219 / A1222 - A1225

chart of types

The instruments are differentiated through the different dimensions of the adjust ring (1) and of the basis ring (2).

instrument Order-No.	acceptance - diameter $D_a$	height $H_2$	(1) adjusting ring Order-No.	(2) basis ring Order-No.
A 1 2 1 6	4 6 , 3 m m	1 2 , 5 m m	0 8 4 0 - 8 0	0 8 4 0 - 3 0
A 1 2 1 7	4 9 , 3 m m	1 6 , 5 m m	0 8 4 0 - 8 1	0 8 4 0 - 3 1
A 1 2 1 8	4 2 , 6 m m	1 2 , 5 m m	0 8 4 0 - 8 2	0 8 4 0 - 3 2
A 1 2 1 9	4 2 , 6 m m	8 , 5 m m	0 8 4 0 - 8 3	0 8 4 0 - 3 2
A 1 2 2 2	4 2 , 6 m m	1 6 , 0 m m	0 8 4 0 - 8 4	0 8 4 0 - 3 4
A 1 2 2 3	5 0 , 5 m m	1 7 , 4 m m	0 8 4 0 - 8 5	0 8 4 0 - 3 5
A 1 2 2 4	4 5 , 6 5 m m	2 0 , 5 m m	0 8 4 0 - 8 6	0 8 4 0 - 3 6
A 1 2 2 5	4 0 , 8 m m	1 6 , 0 m m	0 8 4 0 - 8 7	0 8 4 0 - 3 7

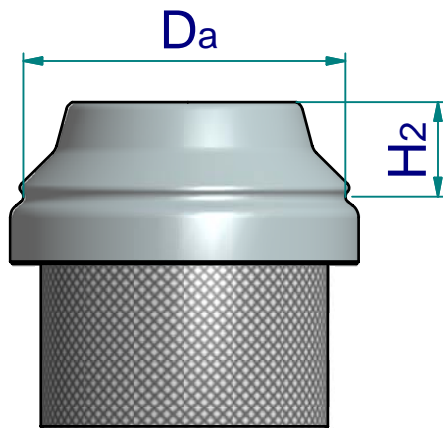

(1) adjust ring

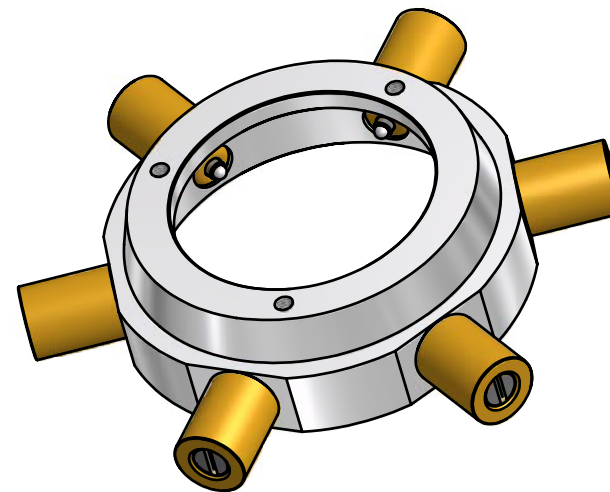

(2) basis ring