



CATENE CHAINS





CATENE CHAINS

**CATALOGO TECNICO GENERALE
GENERAL TECHNICAL CATALOGUE**

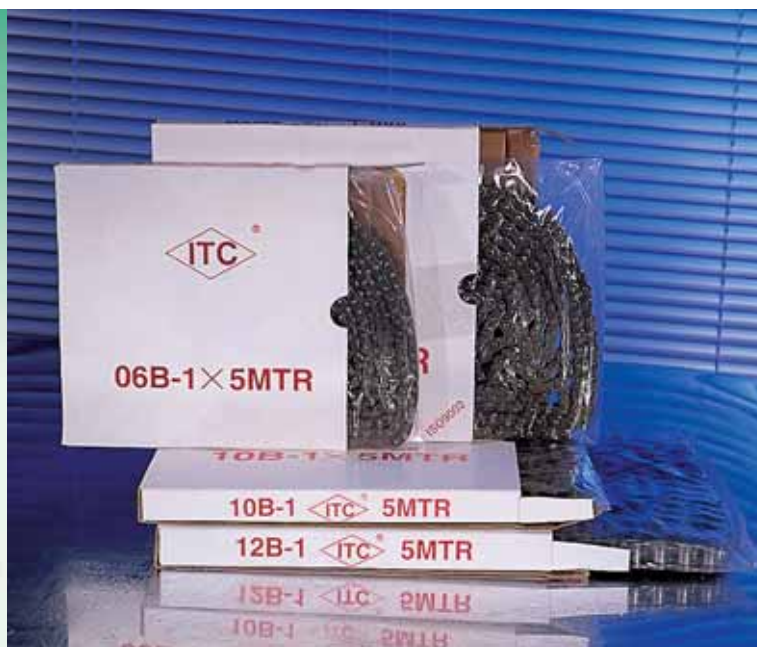

SOMMARIO / CONTENTS**TRASPORTO LEGGERO**
LIGHT TRANSPORT**15 - 68****TRASPORTO PESANTE**
HEAVY TRANSPORT**69 - 73****TRASPORTO ED ACCUMULO**
TRANSPORT AND STORAGE**74 - 78****TRAZIONE E SOLLEVAMENTO**
TRACTION AND LIFTING**79 - 82****AGRICOLTURA**
AGRICULTURAL ROLLER CHAINS**83 - 91****RASCHIANTI**
SCRAPERS**93****PER TRASPORTATORI "A TAPPARELLE"**
FOR FLAT TOP CHAIN TRANSPORTERS**95 - 110**

TRASMISSIONE CON CATENE A RULLI TRANSMISSION WITH ROLLER CHAINS

L'importanza della lubrificazione, è uno dei principali fattori per la determinazione delle prestazioni e durata della trasmissione con catena a rulli.

Una corretta lubrificazione, consente maggiore efficacia nella trasmissione del moto, e se effettuata ad intervalli regolari, ne determinerà una durata maggiore. Di contro, una scorretta manutenzione, pregiudicherà il funzionamento e nonostante l'efficacia del migliore dei progetti, anche la sua più semplice delle funzioni: la durata.

L'usura che si viene a creare fra perno e la bussola, determina la causa che si conclude con l'allungamento della catena.

Per ovviare a questo problema, si è provveduto a creare un interstizio, tra la piastra della maglia interna e la piastra della maglia esterna. Una corretta lubrificazione, provvederà a "colmare" questa specie d'intercapedine, che riceverebbe così l'olio necessario ad una corretta lubrificazione. Il velo d'olio che si verrebbe a creare, nel contatto fra le parti di cui sopra, se debitamente "rabboccato" provvederà ad aumentare la durata della catena stessa, diminuendo al tempo stesso la rumorosità della trasmissione.

*One of the most important factors to determinate performances and life of a transmission with roller chains, is the **lubrication**.*

A good and correct lubrication enables a greater efficacy in motion and when regularly repeated, a longer life. On the other hand, an incorrect upkeep compromises functioning and life.

***The wear** existing between the pin and the sleeve, determinates the cause that ends in chain extension. To avoid this problem, a "space", between the plate of the inner plate and the plate of the outer plate has been created.*

*A correct lubrication helps to **fill this space in**, in this way oil is enough to guarantee a correct working. The veil of oil created by the contact between the above parts, when duly topped up, increases the life and decreases the noisiness of the transmission.*

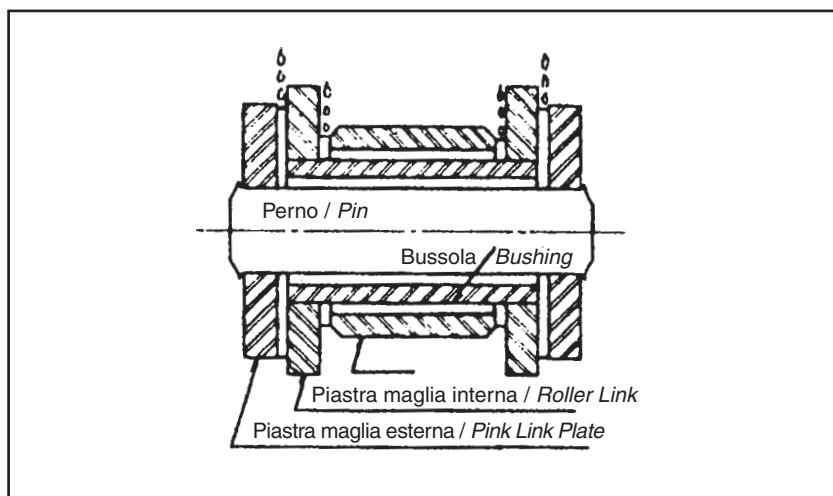

Gli oli consigliabili sono quelli d'elevata qualità. È inutile utilizzare grassi od oli particolarmente ricchi. La caratteristica che fa diventare ottima, una buona lubrificazione, è dettata da una buona viscosità dell'olio impiegato, nonchè dalla temperatura standard dell'ambiente nel quale lavora la catena.

Per questo ulteriore motivo, esistono degli oli, in grado di lavorare a temperature particolarmente elevate. È tuttavia consigliabile, per questo capitolo, affidarsi alle specifiche raffigurate nel riquadro presente in questa introduzione.

Suggested oils are those of high quality, it is useless using grease or oils particularly rich.

A good lubrication becomes excellent when the oil has a good viscosity and when the temperature of surroundings is standard.

For this reason some oils are able to perform with very high temperatures: to have more details, see the specifications expressed in the panel of this introduction.

Temperatura °C <i>Temperature</i>		Lubrificante consigliato <i>Recommended lubricant</i>
Da / From -6	a / to +5	SAE 20
Da / From +5	a / to +38	SAE 30
Da / From +38	a / to +49	SAE 40
Da / From +49	a / to +60	SAE 50

I metodi di lubrificazione, tuttavia, sono indispensabili, ed in quest'ottica, "ITC", ne consiglia alcuni fondamentali.

Lubrificazione manuale.

L'olio viene applicato mediante pennello o nebulizzatore, nell'interstizio esistente fra il rullo della catena ed il perno. Sarà applicato a cicli di circa 8/10 ore, od ad intervalli minori se l'applicazione portasse le parti a seccarsi anticipatamente.

Lubrication methods are essential, for this reason "ITC" advises some of them.

Manual lubrication.

The oil is applied by a brush or a nebulizer inside the space between the roller of the chain and the pin. The application has to be repeated every 8/10 hours, this cycle can be shorter if the application causes advanced drying of the parts.

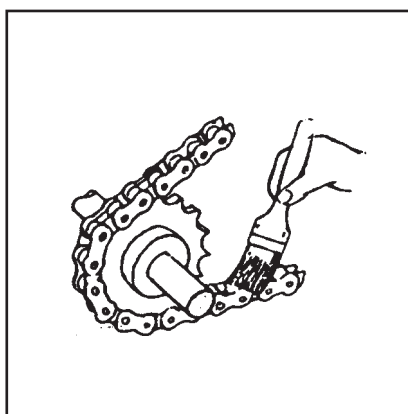

Lubrificazione a goccia.

Può avvenire utilizzando un dispositivo automatico programmabile. Tuttavia quest'applicazione è consigliata qualora la trasmissione non superi la velocità periferica di circa 3 m/sec.

Drip-feed lubrication.

By using an automatic device predisposed to programming. This application is recommended only when the transmission doesn't exceed the peripheral speed of 3 m/sec.

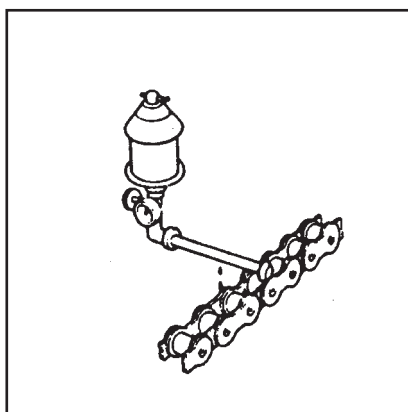

Lubrificazione a bagno d'olio.

È la più semplice, dopo la lubrificazione manuale. La catena, installata all'interno di un carter, nella sua parte inferiore è a contatto con bagno d'olio, il cui livello massimo, non dovrà superare nel suo livello minimo, la mezziera della catena medesima.

La velocità massima consigliata per questo tipo d'applicazione, è di circa 7/8 m/sec.

Bath oil lubrication.

This is the easiest after the manual one. The chain, assembled inside a carter, has its lower part in a bath oil: the maximum level doesn't have to exceed the minimum level of the center line of the chain.

Suggested speed for this kind of chain is about 7/8 m/sec.

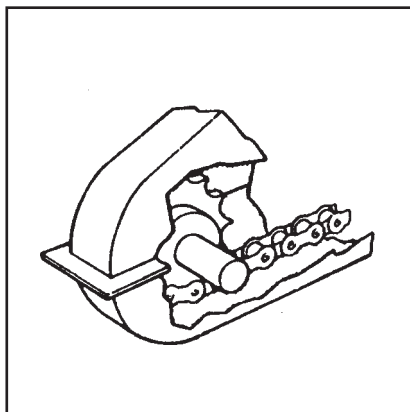
**Lubrificazione forzata.**

Metodo assai indicato per velocità d'esercizio particolarmente elevate (almeno 8-9 m/sec). Mediante una pompa, collegata ad un sistema centrale di lubrificazione, il getto d'olio viene direttamente orientato sulle superfici interne della catena. Il tutto, è preferibile avvenga nel punto più in basso dell'ingranamento.

Pressure lubrication.

This lubrication is suitable for very high speeds (at least 8/9 m/sec). By a pump, that is connected to a central system of lubrication, the oil is directly injected to inner surfaces of chain.

This should preferably happen in the lowest part of the gear.

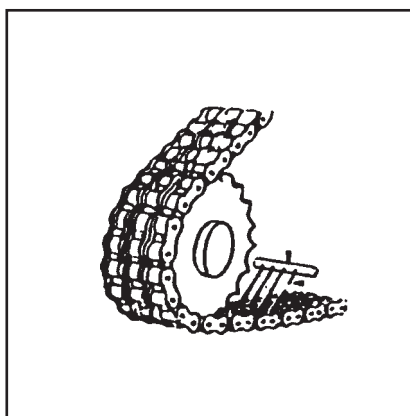

FORMULARIO DI BASE, PER IL CALCOLO DELLE TRASMISSIONI A CATENA

BASIC FORMULARY TO CALCULATE TRANSMISSIONS WITH CHAIN

La determinazione dello sforzo motore, che si viene a creare nei trasportatori e negli elevatori a catena, sono da sempre oggetto di studio specifico, per una giusta determinazione e progettazione della trasmissione con catene a rulli. Sollecitazioni, torsioni varie e flessioni, sono il problema iniziale da riscontrare e se possibile da neutralizzare, già in fase di progettazione.

Qui di seguito, elenchiamo il significato di simboli e lettere, impiegati nelle formule sotto riportate:

α = angolo d'inclinazione dell'elevatore o del trasportatore

C = trazione aggiuntiva necessaria allo scorrimento di tapparelle o tazze

F = coefficiente d'attrito radente, tra catene e guide (vedere tabella)

RF = coefficiente d'attrito volvente (vedere tabella)

$F1$ = coefficiente d'attrito radente tra il materiale da trasportare, sabbia, polvere di vetro, carboni, ecc. ed i canali dei trasportatore

L = lunghezza dei ramo dei trasportatore o dell'elevatore tra il centro dell'albero della ruota comando e quella denominata "rinvio", espressa in metri

P = è lo sforzo periferico espresso in kg. Agisce sulla circonferenza primitiva del sistema volvente (ruote) sforzo o spunto, che dev'essere superato per la messa in moto del meccanismo.

$P1$ = è lo sforzo periferico totale, corrispondente a V , agente sulla circonferenza primitiva della ruota (pignone o puleggia di comando), maggiorato di " C " e delle resistenze passive della trasmissione, precisamente del:

10% per gli attriti degli assi di comando e di rinvio

15% per ogni coppia d'ingranaggi di riduzione

50% se la riduzione è costituita da un riduttore a vite ad elica

Q = è il peso della catena, tapparelle, piastre, tazze, per metro lineare

q = è il peso del materiale, per metro di trasportatore (sabbia, polveri, carbone, ecc.)

N = potenza espressa in HP occorrente = $\frac{P1 \times V''}{75}$

la potenza necessaria ottenuta sarà poi, eventualmente maggiorata a seconda delle casualità, per tener conto dei sovraccarichi in partenza, ecc.

$Q1$ = potenza d'elevazione o portata in tonn./h
 $3,6 \times g \frac{P \times V''}{d} e p = \frac{d Q1}{3,6 \times g \times V''}$

g = grado di riempimento tazze = 0,7/0,8 per materiali polverosi, e 0,4/0,5 per materiali di pezzatura grossa o media

d = distanza, tra una tazza e l'altra, espressa in metri

The identification of engine stress, which is present both in transporters and in chain elevators, must be studied in order to project and develop transmission with roller chains. Strains, torsions and bends, if present, have to be neutralized during design.

Below, meaning of letters and symbols used in the formula:

α = angle of inclination of transporter or elevator
 C = additional traction for flat-top chains and cups sliding

F = coefficient of sliding friction, between chains and guides (see table)

RF = coefficient of rolling friction (see table)

$F1$ = coefficient of sliding friction between goods to transport (sand, dust of glass, carbons...) and races of transporter.

L = length of transporter or elevator, between the center of controlling wheel and center of "returning" wheel, expressed in mts.

P = peripheral stress expressed in kg. It works on wheels pitch line: this stress has to be surpassed to start the mechanism

$P1$ = total peripheral stress, equal to V , working on wheel pitch line (sprocket or driving pulley) increased by " C " and by passive resistances of transmission. In detail:

10% for friction of return and control axles

15% for each couple of reduction gear

50% if reduction derives from a worm reduction unit or a propeller reduction unit

Q = weight of chain, flat top chains, plates, cups, for linear meter.

q = weight of material, for meter of transporter (sand, dusts, carbon...)

N = power in HP = $\frac{P1 \times V''}{75}$ the power obtained can be uprated in some cases: initial over loads for example.

$Q1$ = elevation power or capacity load in tonn/h
 $3,6 \times g \frac{P \times V''}{d} e p = \frac{d Q1}{3,6 \times g \times V''}$

g = level of cups filling = 0,7/0,8 for dusting materials and 0,4/0,5 for medium or big size materials

d = distance, between one cup and the other, expressed in meters

$V'' =$ Velocità espressa in m/sec, è = $0,105 \times R \times n$; oppure:

$$\frac{(\pi D n)}{60}$$

$R_p =$ raggio primitivo della ruota di comando espressa in metri

$n =$ numeri di giri/minuto, della ruota comando

$p =$ peso in kg dei materiali che ogni tazza può contenere (considerandola piena) senza cioè tenere conto del calcolo del grado di riempimento "g"

coefficienti di attrito radente:

$F = 0,33$	fra metallo e metallo
$F_1 = 0,59$	fra metallo e carbone
$= 0,33$	fra metallo ed antracite
$= 0,53$	fra metallo e cenere (scorie umide)
$= 0,60$	fra metallo e sabbie
$= 0,59$	fra metallo e calcare
$= 0,33$	fra metallo e grano

coefficienti di attrito volvente:

$$RF = X \times \frac{d}{D} + \frac{2y}{D}$$

Dove:

$X = 0,33$ fra metallo e metallo (non lubrificato)

$X = 0,20$ fra metallo e metallo (lubrificato)

$D =$ diametro del rullo, espresso in mm.

$d =$ diametro del perno o della bussola intorno ai quali ruota il rullo (in mm.)

$y =$ mm. 0,75 fra metallo e metallo in condizioni medie

Valori di C:

Per elevatori verticali 0,15 ÷ 0,40 P

Per trasportatori inclinati 0,05 ÷ 0,15 P

Per trasportatori orizzontali 0,05 ÷ 0,10 P

Tensione nelle catenarie

Nel caso di un elevatore verticale a catene semplici, lo sforzo di tensione sarà uguale a quello rappresentato dallo sforzo motore P.

Ovviamente, nel caso di catenaria doppia, lo sforzo di tensione, in ogni catena, corrisponderà alla metà di quanto sopra indicato.

Nel caso di trasportatori orizzontali, lo sforzo di tensione sulle catene, sarà uguale allo sforzo di trazione nel caso della catena semplice, oppure corrisponderà alla metà di tale sforzo, nel caso di catena doppia.

Nel caso invece di trasportatori inclinati, si calcolerà lo sforzo della catena come somma degli sforzi prodotti dalla quota di peso del tratto portante e della quota del peso trasportato, purchè l'inclinazione sia sufficiente affinché il tratto di ritorno possa scendere per semplice gravità. Se detta inclinazione fosse insufficiente, ed il tratto di ritorno debba essere forzato a scendere dalla ruota, allora si dovrà tener conto anche di questo sforzo.

Sforzo motore. Elevatori verticali

$$1) P = (q + Q) \times L$$

$V'' =$ speed expressed in m/sec is = $0,105 \times R \times n$; or:

$$\frac{(\pi D n)}{60}$$

$R_p =$ primitive radius of controlling wheel, expressed in m

$n =$ number of revolutions per minute, of controlling wheel

$p =$ weight in kg of materials that every cup can contain (when full), without "g" degree of filling up

coefficients of grazing friction:

$F = 0,33$	between steel and steel
$F_1 = 0,59$	between steel and carbon
$= 0,33$	between steel and anthracite
$= 0,53$	between steel and ash (damp slags)
$= 0,60$	between steel and sands
$= 0,59$	between steel and limestone
$= 0,33$	between steel and wheat

coefficients of rolling friction:

$$RF = X \times \frac{d}{D} + \frac{2y}{D}$$

Where:

$X = 0,33$ between steel and steel (not lubricated)

$X = 0,20$ between steel and steel (lubricated)

$D =$ roller diam. expressed in mm

$d =$ diameter of pin or sleeve, around which rotates the roller (in mm)

$y =$ mm. 0,75 between steel and steel in medium conditions

C values:

For vertical elevators 0,15 ÷ 0,40 P

For slanting conveyors 0,05 ÷ 0,15 P

For horizontal conveyors 0,05 ÷ 0,10 P

Strech in catenary

In a vertical elevator with single strand chains, tension stress is equal to "P" stress engine. When the catenary is double, tension stress in every chain, is half of what above indicated. In horizontal conveyors, tension stress on chains is the same as the one of single strand chain or half of this stress if the chain is double.

In sloping conveyors the stress is in this way calculated: the sum of stress produced from the weight of bearing section and from transported weight. The inclination has to be sufficient and the returning way has to go down by simple gravity.

When this inclination is not enough and the returning section is forced to go down from the wheel, in this case we have to note this stress as well.

Engine stress. Vertical elevators

$$1) P = (q + Q) \times L$$

Ecco alcuni esempi:

ESEMPIO N. 1

Elevatori verticali:

Elevatore a tazze per carbone coke pezzatura media peso specifico circa kg 400 m³. Portata richiesta tonn 4,8 ora = 12 m³. Interasse dell'elevatore mt 10.

Fissati:

g = 0,5
d = mt 0,330
v = mt 1"
n = 40 a 1'
Rp = mt 0,250
Q = kg 5 (peso per mt di catena tazze, ganci, ect.)
q = kg 1,300 peso per mt dei materiale elevato

Il sistema di tensione è a vite, ma costruito razionalmente. 1 coppia di ingranaggi di riduzione con rendimento e = 0,85.

Assi montati su cuscinetti a sfere.

Calcolo portata:

$Q_1 = 3,6 \text{ g} \frac{p}{d} v''$ e quindi: $4,8 = 3,6 \text{ g} \frac{p}{d} \times l = 4,8 =$

$$3,6 \times 0,5 \times \frac{p}{0,330} \times l =$$

da cui:

$$p = \frac{d Q_1}{3,6 \times g \times v''} = \frac{0,330 \times 4,8}{3,6 \times 0,5 \times l} = \frac{1,58}{1,8}$$

= kg 0,880 (peso di ogni tazza teoricamente piena).

Infatti:

$$Q_1 = 3,6 \times 0,5 \times \frac{0,880}{0,330} \times l = 4,8 \text{ tonn/ora.}$$

Controllo della portata:

Per L = 10 mt = a 31,5 tazze a kg 0,880 cad.
= (x g = 0,5) = 0,440 kg cad.

Quindi N. 31,5 tazze x kg 0,440 = kg 13,325 per 10 mt di L.

Siccome la velocità è di 1 mt" ne consegue che si eleveranno in 10 " kg 13,325 di materiale, e quindi in 1" = = kg 1,3325, e in un'ora kg 1,3325 x 3660," = kg 4,800.

Calcolo della potenza occorrente:

$$P = (q + Q) \times L$$

$$P1 = P + C + \text{resistenze passive}$$

$$P = (q + Q) \times L = (1,300 + 5) \times 10 = \text{kg } 65 \sim$$

$$P1 = 65 + C + (\text{resistenze passive}) = (65 + 0,2 P) + 0,15 = (P + C) = 78 + (0,15 \times 78) = \text{kg } 90.$$

Conseguentemente:

$$N = \frac{P_1 \times v''}{75} = \frac{90 \times l}{75} = 1,2 \text{ HP potenza effettiva da applicarsi.}$$

ESEMPIO N. 2

Trasportatore orizzontale a tapparelle o a nastro che portano il materiale. Abbiamo da trascinare sopra di un piano lungo mt 10 a mezzo di catene con rulli di scorrimento non lubrificati (F = 0,33) del diametro di mm 100 e ruotanti intorno a degli assi di mm 38, un peso di kg 2000, dei quali kg 800 sono rappresentati dal peso della catena ed accessori (0) e kg 1200 dal carico (q).

Some examples:

EXAMPLE No 1

Vertical elevators:

Cups elevator for coke coal, medium size, specific weight kg 400 m³ more or less. Capacity 4,8 ton per hour = 12 m³. Distance between centers of elevator 10 mt.

Fixed:

g = 0,5
d = mt 0,330
v = mt 1"
n = 40 a 1'
Rp = mt 0,250
Q = 5 kg (per cups chain mt, hooks, etc)
q = 1,300 kg per mt of raised material

Tension system is by screw, but rationally manufactured. 1 pair of reduction gears with efficiency e = 0,85. Axed assembled on roller bearings.

Calculation of capacity:

$$Q_1 = 3,6 \text{ g} \frac{p}{d} v'' \text{ therefore: } 4,8 = 3,6 \text{ g} \frac{p}{d} \times l = 4,8 =$$

$$3,6 \times 0,5 \times \frac{p}{0,330} \times l =$$

from where:

$$p = \frac{d Q_1}{3,6 \times g \times v''} = \frac{0,330 \times 4,8}{3,6 \times 0,5 \times l} = \frac{1,58}{1,8}$$

= 0,880 kg (weight of every cup, full).

Infact:

$$Q_1 = 3,6 \times 0,5 \times \frac{0,880}{0,330} \times l = 4,8 \text{ tonn/hour.}$$

Check of capacity:

For L = 10 mt = a 31,5 cups of kg 0,880 cad.
= (x g = 0,5) = 0,440 kg each.

Therefore No 31,5 cups for kg 0,440 = kg 13,325 for 10 mt of L.

Speed is 1 mt", therefore in 10", kg 13,325 of materials will be raised in 1h 1" = 1,3325, in 1h kg 1,3325 x 3660," = kg 4,800.

Calculation of necessary power:

$$P = (q + Q) \times L$$

$$P1 = P + C + \text{passive resistances}$$

$$P = (q + Q) \times L = (1,300 + 5) \times 10 = \text{kg } 65 \sim$$

$$P1 = 65 + C + (\text{passive resistances}) = (65 + 0,2 P) + 0,15 = (P + C) = 78 + (0,15 \times 78) = \text{kg } 90.$$

Therefore:

$$N = \frac{P_1 \times v''}{75} = \frac{90 \times l}{75} = 1,2 \text{ HP effective power to apply.}$$

EXAMPLE No 2

Horizontal flat top chain conveyors or orizontal belt conveyor to transport the stuff. A weight of 2000 kg has to be trasported on a 10 mt. level: 800 kg are the weight of the chain and its accessory (o), the other 1200 kg. are the weight of the load (q). This level works thanks to chains with not lubricated sliding rollers (F = 0,33), of 100 mm diameter that rolls round mm 38 axles.

Applichiamo la formula: $P = (2 \times Q + q) \times (L \times RF) =$

dove $RF = X \times \frac{d}{D} + \frac{2 \times y}{D} = 0,33 \times \frac{38}{100} + \frac{2 \times 0,75}{100} = 0,1606$

$$P = (2 \times 80 + 120) \times (10 \times 0,1606)$$

$$P = (160 + 120) \times (1,606)$$

$$P = 280 \times 1,606 = \text{kg } 449.$$

Lo sforzo motore totale di trascinamento P_1 sarà eguale a P maggiorato come abbiamo visto precedentemente delle resistenze passive.

La potenza N da applicarsi, $N = \frac{P_1 \times v''}{75}$

La potenza ottenuta sarà maggiorata a seconda dei casi, (lunghezza del trasportatore, natura del carico e del sistema di carico) sino ad una volta e mezzo per tenere conto dell'eventuale maggiore sforzo per avviamento sotto carico.

ESEMPIO N.3

Trasportatore inclinato a tapparelle portanti il materiale. Distanza fra i centri degli assi di comando e di rinvio mt 50. Inclinazione 23° .

Il peso Q del trasportatore a vuoto è, per mt 1 di kg 136. Il peso q del materiale da trasportare è per mt 1 di kg 297. Le catene hanno dei rulli lubrificati del diametro di mm 152.

I detti rulli ruotano attorno a dei perni del diametro di mm 38.

Quindi:

$$L = 50 \text{ mt}; \alpha = 23^\circ; \text{sen } 23^\circ = 0,39; \text{cos } 23^\circ = 0,92.$$

$$Q \text{ kg } 136; q = \text{kg } 297.$$

$$RF = 0,20 \times \frac{38}{152} + \frac{2 \times 0,75}{152} = 0,06.$$

Abbiamo tenuto $X = 0,20$ per rulli lubrificati.

Applichiamo la formula:

$$P = L (Q + q) \times [(\text{cos } \alpha \times RF) + \text{sen } \alpha] + (Q \times L) [(\text{cos } \alpha \times RF) - \text{sen } \alpha].$$

$$P = 50 \times (136 + 297) \times (0,92 \times 0,06) + 0,39 + (136 \times 50) \times (0,92 \times 0,06) - 0,39.$$

$$P = 21.650 \times (0,445) + 6.800 \times (-0,335).$$

$P = 9.634 - 2278 = 7356 \text{ kg}$ che è lo sforzo periferico agente sulla circonferenza primitiva delle ruote di comando. Lo sforzo motore così determinato dovrà essere aumentato delle resistenze passive a seconda di quanto visti precedentemente, per ottenere P_1 .

La potenza N da applicare in HP sarà: $= \frac{P_1 \times v''}{75}$

Bisognerà inoltre maggiorare la potenza così ottenuta, a seconda dei casi, sino ad una volta e mezzo per tenere conto delle eventuali partenze sotto carico. Precisiamo per questo esempio che lo sforzo torcente o sforzo periferico sarà dunque in kg 7356. Mentre la tensione totale sulle catene kg 9634 ($P + (L \times q) \times \text{sen } \alpha$) ossia ($7356 + (50 \times 136) \times 0,39$). Quella flettente per il calcolo degli assi sarà = a kg 11912 ossia $9634 + 2278$. Anche per i calcoli dei trasportatori precedenti bisognerà procedere come sopra, sempre facendo attenzione, se il tratto di ritorno scende per semplice gravità o meno. Nell'esempio sopra elencato abbiamo aggiunto la tensione delle catene, appunto anche questo sforzo dato che l'inclinazione non era sufficiente a fare scendere il tratto di ritorno per semplice gravità.

The formula: $P = (2 \times Q + q) \times (L \times RF) =$ must be used

where $RF = X \times \frac{d}{D} + \frac{2 \times y}{D} = 0,33 \times \frac{38}{100} + \frac{2 \times 0,75}{100} = 0,1606$

$$P = (2 \times 80 + 120) \times (10 \times 0,1606)$$

$$P = (160 + 120) \times (1,606)$$

$$P = 280 \times 1,606 = \text{kg } 449.$$

P_1 total stress engine of dragging is equal to P increased by passive resistances.

N. power to apply, $N = \frac{P_1 \times v''}{75}$

The detained power will be increased, case by case, (length of conveyor, kind of load and kind of loading system) up to 1 time and half to include possible greater stress in case of starting under load.

EXAMPLE No 3

Sliding flat top chain conveyor transporting material. Distance among centers of control axles and return 50 mt., inclination 23° .

The weight Q of an empty conveyor is for 1 mt of 136 kg. The weight q of stuff to transport is for 1 mt of 297 kg. Chains have lubricated roller of 152 mm. diameter. These rollers rotate round 38 mm. diam. pins.

Therefore:

$$L = 50 \text{ mt}; \alpha = 23^\circ; \text{sen } 23^\circ = 0,39; \text{cos } 23^\circ = 0,92.$$

$$Q \text{ kg } 136; q = \text{kg } 297.$$

$$RF = 0,20 \times \frac{38}{152} + \frac{2 \times 0,75}{152} = 0,06.$$

Where $X = 0,20$ for lubricated rollers.

The following formula has to be applied:

$$P = L (Q + q) \times [(\text{cos } \alpha \times RF) + \text{sen } \alpha] + (Q \times L) [(\text{cos } \alpha \times RF) - \text{sen } \alpha].$$

$$P = 50 \times (136 + 297) \times (0,92 \times 0,06) + 0,39 + (136 \times 50) \times (0,92 \times 0,06) - 0,39.$$

$$P = 21.650 \times (0,445) + 6.800 \times (-0,335).$$

$P = 9.634 - 2278 = 7356 \text{ kg}$ which is the peripheral stress acting on control wheels pitch line. The obtained engine stress has to be increased by passive resistances, as seen before, to get P_1 .

N power to apply in HP, will be: $= \frac{P_1 \times v''}{75}$

Moreover the obtained power will be increased, case by case, up to 1 time and half to include possible starting under load. For this example, the twisting stress or peripheral stress is in kg 7356. Total stretch on chains is 9634 kg. ($P + (L \times q) \times \text{sine } \alpha$) that is ($7356 + (50 \times 136) \times 0,39$).

The bending tension of axles will be = 11912 kg whereas $9634 + 2278$.

For calculations of previous conveyors, we had to proceed as above, important is to pay particular attention to way of returning section: if this descends for gravity or other. In our example; in fact, we had to add a further stress: the chains tension: the inclination wasn't enough to enable the returning section to descend for simple gravity.

GLI ATTACCHI "ITC" ED IL LORO MONTAGGIO

"ITC" ATTACHMENTS AND THEIR ASSEMBLING

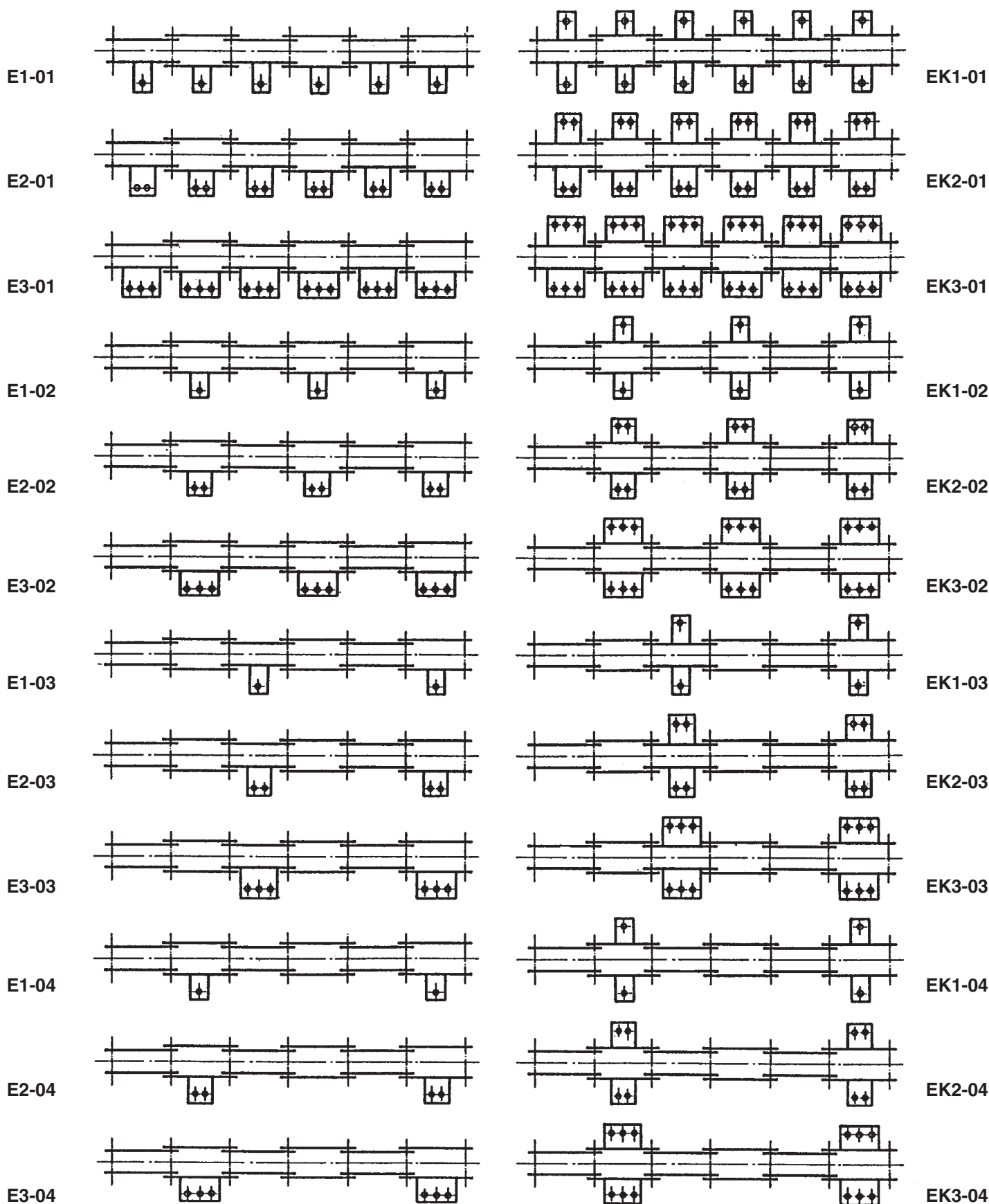

GLI ATTACCHI "ITC" ED IL LORO MONTAGGIO

"ITC" ATTACHMENTS AND THEIR ASSEMBLING

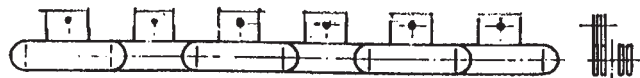

EM 35-01

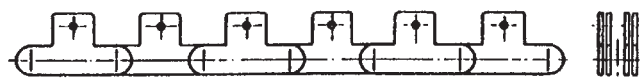

EM 1-01



EM 35/2-01

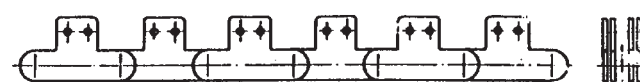

EM 2-01



EM 35-02



EM 1-02



EM 35/2-02

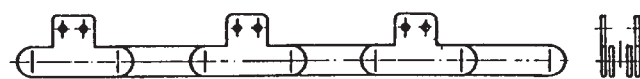

EM 2-02

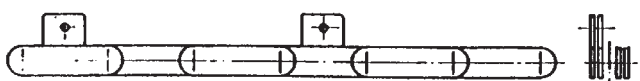

EM 35-03

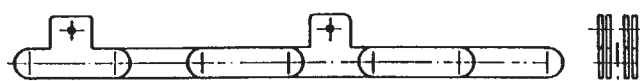

EM 1-03

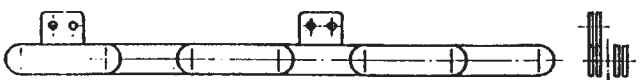

EM 35/2-03

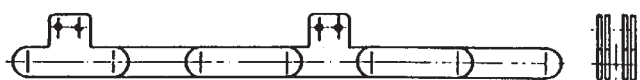

EM 2-03



EM 35-04



EM 1-04



EM 35/2-04

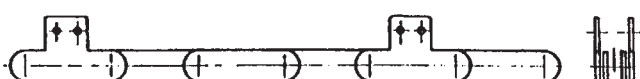

EM 2-04

TRASPORTO LEGGERO / LIGHT TRANSPORT

Ecco qui di seguito elencate, le normative basilari, osservate durante i processi produttivi. Sono fra i più alti esempi di standard qualitativi che fanno di ITC, un marchio d'altissima affidabilità e qualità.

MATERIALI:

- Catene standard al carbonio: tutti i componenti delle catene, subiscono un trattamento termico. Le parti assoggettate ad usura, quali perni e bussole, ad esempio, vengono ulteriormente indurite, con trattamenti di cementazione e tempra ad induzione, in atmosfera controllata, e se il caso lo richiedesse, su alcune di esse, verrebbe attuata anche una cromizzazione. Il controllo di laboratorio, garantisce l'efficacia totale di tutti questi processi di trattamenti protettivi.
- Altre tipologie di catene, subiscono trattamenti superficiali di differente potere protettivo:
 - Zincatura o zincocromatura
 - Tropicalizzazione
 - Nichelatura
 - Trattamenti galvanici speciali
- Catene in acciaio Inox (AISI 304 L)
Per la massima resistenza all'attacco di agenti chimici (anticorrosione).

PRESTIRAGGIO O PRECARICO:

Tutte le catene **ITC**, facenti parte della linea “**TRASPORTO LEGGERO**”, vengono precaricate e rodiate, secondo predeterminati criteri tecnomeccanici, per assicurare una corretta applicazione in ogni campo lavorativo, inducendo alle catenarie, particolare resa, contro usura, danneggiamenti ed allungamenti.

SPEZZONI E COMPOSIZIONI VARIE:

Per le applicazioni particolareggiate, richiedenti speciali impieghi, con tratti (rami) di catenarie con lunghi sviluppi e necessarie tolleranze sul totale dei medesimo, **ITC** fornisce catene spezzonate e/o composte, secondo le richieste dell'Utilizzatore, eseguendo oltre che l'operazione suppletiva di composizione dello spezzone, anche adeguati controlli sugli sviluppi stessi, contrassegnandone le zone di connessione, onde agevolare l'operazione di montaggio.

MANUTENZIONE E LUBRIFICAZIONE:

Tutte le catene **ITC**, della linea “**TRASPORTO LEGGERO**”, vengono sottoposte a lubrificazione di carattere Standard, al momento del confezionamento ed imballaggio. Lubrificazioni specifiche, con olii e grassi particolari, possono venire eseguiti (a richiesta), con utilizzo di lubrificanti particolarmente adatti all'usura (Bisolfuro di molibdeno), alle alte temperature (220-240°C).

CATENE SPECIALI SU SPECIFICHE DEL CLIENTE:

ITC produce qualsiasi tipologia di catena, destinata a qualsivoglia comparto produttivo. Ogni tipo d'applicazione o problematica, viene risolta a livello produttivo, dai vari centri di produzione, evidenziati nelle fotografie, raffigurate nella prima parte di questo catalogo. A seguito di eventuali ulteriori accordi, **ITC** può produrre catene d'ogni tipo e formato, anche in regime d'**ESCLUSIVA**.

We would like to remind you, general and basic rules that are followed during production process: qualitative standards are the highest, in order to grant all our customers a reliable brand.

MATERIALS:

- *Standard carbon chains: all chains components, are thermally treated. Part usually more exposed to wear (sleeves and pins for example) are even more hardened with casehardening and induction hardening operations. These treatments take place in a controlled atmosphere and if necessary a further chromizing operation could occur. A laboratory control guarantees the total efficacy of all these protective operations.*
- *Other chains are superficially treated with different protective operations:*
 - *galvanizing or zinc-chromium plating*
 - *tropicalization*
 - *nickel-plating*
 - *special galvanic treatments*
- *Stainless steel chains (AISI 304 L)
For the highest resistance against chemical agents (anticorrosion)*

PRE-STRETCHING OR PRE-LOADING:

All ITC chains, belonging to “LIGHT TRANSPORT” are pre-loaded and broken in, in accordance with technical-mechanics rules which assure a correct application in every field of working. In this way all chains have a great resistance against wear, elongations and damages.

CUT DOWN SIZES AND DIFFERENT COMPOSITIONS:

For special applications, where very long chains and particular tolerances are presents, ITC can supply you with cut down size chains and/ or chains as per customers requirements. Infact besides cutting the chains as per request, ITC executes all controls on them and indicates the connection parts, to facilitate mounting operation.

UPKEEP AND LUBRICATION:

All ITC chains belonging to “LIGHT TRANSPORT” are previously treated with standard lubrication, during packing operation. Special lubrications with particular oils and grease, can be, under request, executed: lubricants suitable for high temperatures (220-240°C) and against wear (bisulphide of molybdenum) can be used.

SPECIAL CHAINS AS PER CUSTOMER'S REQUIREMENT:

*ITC produces all types of chains, for all types of productive compartment. Any kind of application or problem is solved during productive level from different production centers, that are showed with pictures in the first part of this catalogue. If further agreements are presents, ITC can produce any type of chain also with **EXCLUSIVITY**.*

TRASPORTO LEGGERO / LIGHT TRANSPORT**CATENE A RULLI “SERIE ISO” (Norme europee)**
“ISO SERIES” ROLLER CHAINS (European rules)

Questa denominazione, raggruppa quelle catene a rulli, abitualmente costruite secondo precise normative, adottate dall'unificazione di sistemi tecnologici e di misurazione, di alcuni Paesi europei, fra i quali l'Italia, la Francia, la Germania ed il Regno Unito.

L'unificazione di questi sistemi (ISO/R 606-1982/DIN 8187), consente la totale eliminazione di divergenze costruttivo-dimensionali, fino ad ora esistenti, fra le catene a rulli costruiti nei vari Paesi europei, con l'ottenimento di una coerente e vantaggiosa equivalenza, facilitandone al tempo stesso una logica e meno costosa intercambiabilità. Le catene a rulli della “SERIE ISO” sono quelle con il maggior impiego in Europa, per le trasmissioni di potenza. Queste catene della “SERIE ISO” sono costruite, quindi disponibili da standard, con 1, 2, 3 ed anche 4 file di rulli.

This name includes all roller chains that are normally manufactured in accordance with accurate rules accepted and recognized by some European countries, such as Italy, France, Germany and U.K. The unification of these technological and measuring systems (ISO/R 606-1982/DIN 8187), eliminates any manufacturing difference previously existing among roller chains constructed in different European countries.

In this way the product is interchangeable and equivalent. “ISO SERIES” chains are the most used in Europe for power transmission: these can be standard, single-double-triples strands or even with 4 strands of rollers.

Es.: catena ad 1 fila di rulli (semplice)

Example: single strand roller chain



Es.: catena a 2 file di rulli (doppia)

Example: double strands roller chain

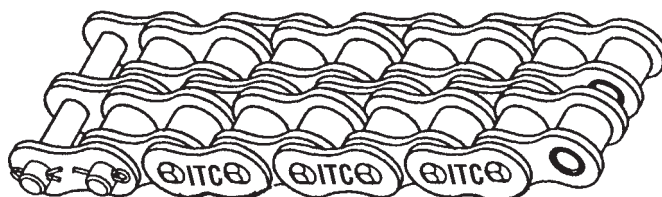
**CATENE A RULLI “SERIE AMERICANA” (ANSI-ASA)**
“AMERICAN SERIES” ROLLER CHAINS (ANSI-ASA)

Sono costruite secondo l'unificazione Americana, denominata (ANSI B 29.1) e, si propone, come alternativa alle corrispondenti della “Serie ISO” sopra riportate. Per facilitarne i criteri di scelta, vengono abitualmente elencate e raffigurate separatamente da quelle della “Serie ISO”, sebbene il loro campo applicativo è pressoché identico a queste, col vantaggio però, rispetto alla “Serie ISO”, derivante da una maggiore resistenza alla fatica, dovuta alla loro caratteristica progettuale. Caratteristica che ha reso il sistema unificato “ANSI B 29.1”, largamente adottato anche in Europa.

Per facilitarne l'appellativo, denomineremo le catene di questa unificazione Americana, con la sigla “ASA”. Le catene a rulli ITC della serie “ASA”, normalmente sono disponibili, come per la “Serie ISO”, ad 1, a 2, 3 ed anche 4 file di rulli.

Manufactured in accordance with the American unification, they are an alternative to “ISO series” above named. To make their choice easier, these chains are separately indicated even if their application field is almost the same as “ISO series”: the main difference is their higher endurance to stress, coming from a planning characteristic. Thanks to this characteristic the “ANSI B 29.1” system, is widely used in Europe too.

We call this chains “ASA”, and the “ITC” chains of “ASA” series are the same as above: standard, single-double-triple strands or even with 4 strands of rollers.

TRASPORTO LEGGERO / LIGHT TRANSPORT

I prodotti "ITC" sono da sempre in costante perfezionamento.

Da sempre "ITC" rivolge particolare attenzione verso investimenti, tendenti a valorizzare la qualità e l'affidabilità dei suoi prodotti, a totale garanzia di un corretto funzionamento.

Tutto questo ha consentito ad "ITC" di perfezionare piani di sviluppo e di progettazione dei propri prodotti, migliorandone i già elevati standard qualitativi, ampiamente riconosciuti dall'elevato numero di utilizzatori, sparsi in tutto il mondo.

Processo produttivo, controllo dimensionale e funzionale, lubrificazione e collaudo, e per finire confezionamento e relativo imballaggio, sono un tutt'uno, che s'identifica nell'**ALTA QUALITÀ** oramai raggiunta da "ITC", che ha di recente ottenuto la certificazione "ISO 9002" rispondente ai più rigidi canoni di controllo.

The "ITC" products have always been in continuous improvement, "ITC" attaches particular importance to investments, in order to improve and develop the quality and reliability of its products for a total safe working. In this way "ITC" is constantly perfecting development designs and projects for its products, improving therefore the already high qualitative standards, widely known from many users all around the world.

Productive process, dimensional and functional control, lubrication, acceptance test, and packing are carefully carried and to obtain high quality in which "ITC" identify it self.

"ITC" has recently obtained the "ISO 9002" quality system certification, to guarantee all the customers a product manufactured in accordance with the strictest rules.

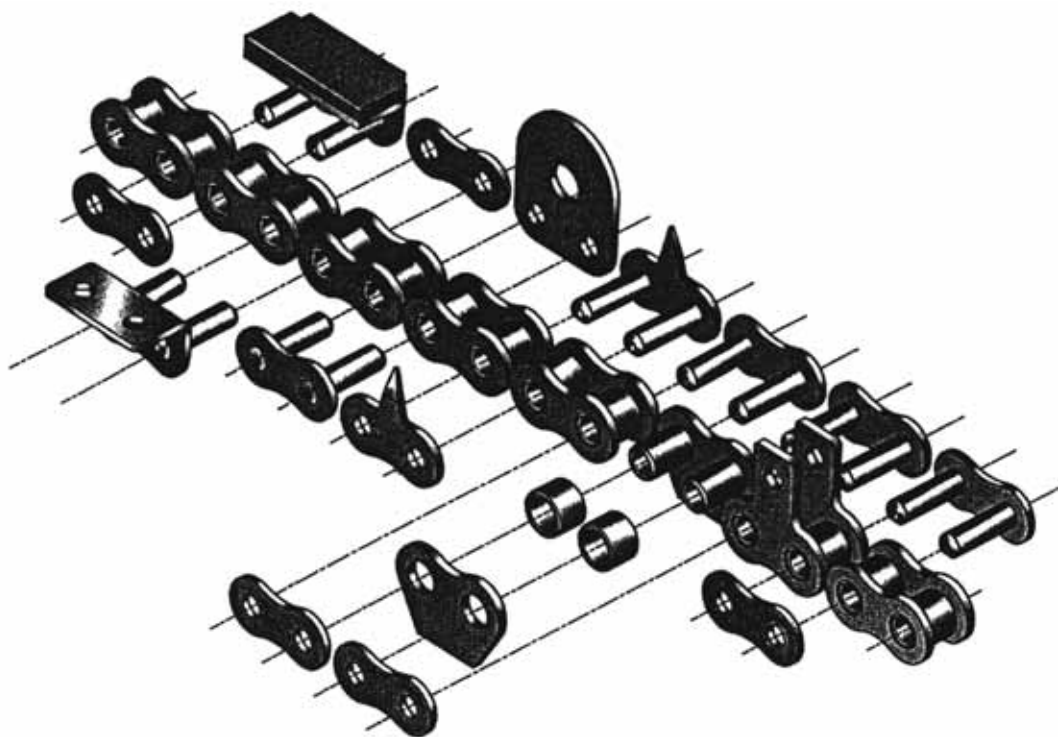

TRASPORTO LEGGERO / LIGHT TRANSPORT

**MODALITÀ D'IDENTIFICAZIONE DI UNA CATENA A RULLI
"ITC" CON ATTACCHI
IDENTIFICATION OF AN "ITC" ROLLER CHAIN
WITH ATTACHMENTS**

Gli attacchi sotto raffigurati, possono essere assemblati, su di 1 solo lato, oppure sui 2 lati della catena "ITC". È inoltre possibile identificare questi attacchi, utilizzando le designazioni sotto riportate:

The following attachments can be assembled on one side or on both sides of "ITC" chain. To identify these attachments the following designations can be used.

Attacchi da 1 solo lato / <i>One side attachments</i>	E1	E2	EM35	EM35-2	Etc.
Attacchi sui 2 lati / <i>Both sides attachments</i>	EK1	EK2	EM1	EM2	Etc.

E1 **EK1**

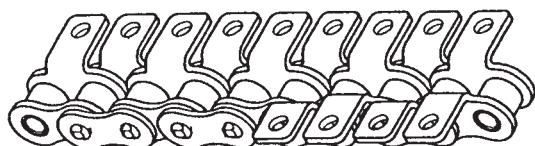

E2 **EK2**

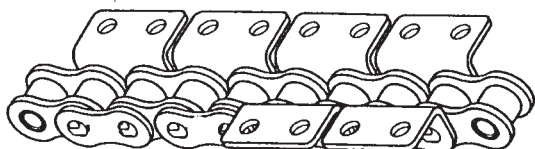

EM35

EM1

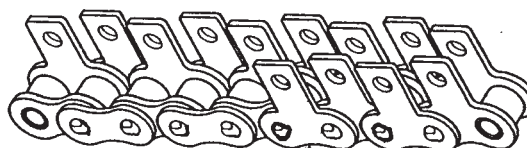

EM35-2

EM2



Quando però l'attacco, non è un'aletta, ma bensì un perno sporgente, la sigla d'identificazione muta come da suggerimento sotto riportato:

ED1 = ovvero quando l'attacco (in questo caso perno sporgente) è costituito da 1 pezzo per ogni maglia.

ED2 = ovvero quando l'attacco (in questo caso "perno sporgente") è costituito da 2 pezzi per ogni maglia.

When the attachments is not a "attachment linkplates" but a extending pin, the designations are the following:

ED1 = the attachment (extending pin) is formed by 1 pcs for each link.

ED2 = the attachment (in this case "projecting pin"), is formed by 2 pcs for each link.

ED1

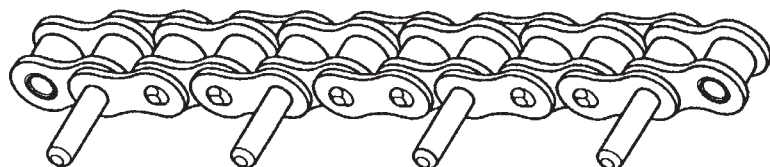

ED2

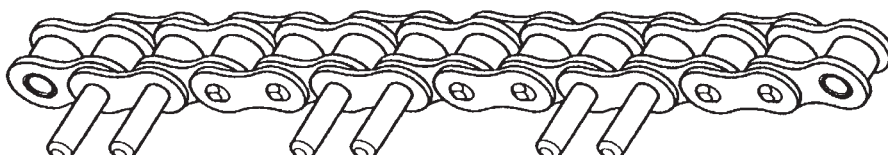

TRASPORTO LEGGERO / LIGHT TRANSPORT**PARTI STACCATE
DETAILED DESCRIPTION**

Maglia interna
Roller link



Giunto con copiglia
Connecting link with split pin

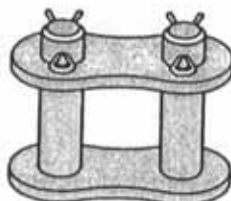

Giunto con molletta
Connecting link with spring clip

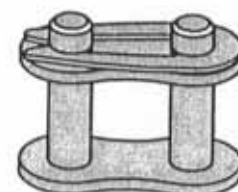

Maglia esterna
Pin link

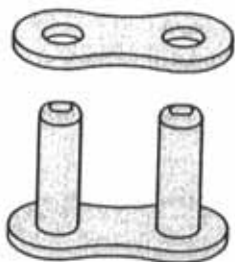

Falsa maglia con copiglia
Offset link with split pin

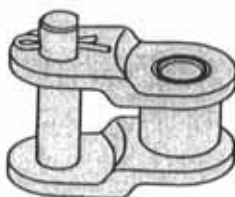

Falsa maglia a 3 rulli
3 rollers offset link

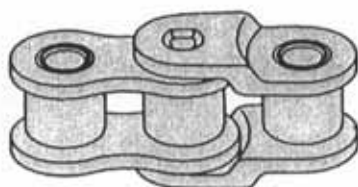

Molletta
Spring clip

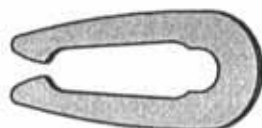

Perno
Pin



Copiglia
Split pin



TRASPORTO LEGGERO / LIGHT TRANSPORT

CATENE A RULLI SEMPLICI
SINGLE STRAND ROLLER CHAINS

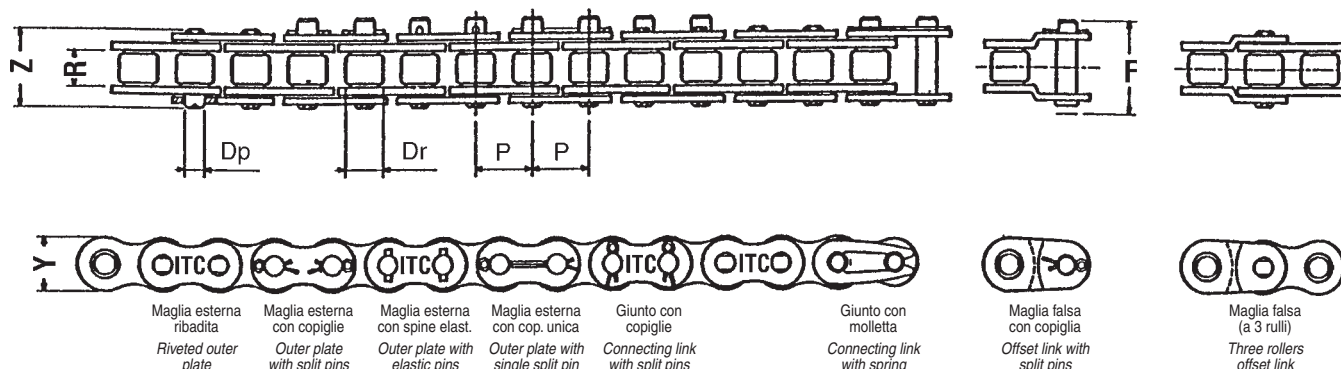

SERIE EUROPEA / EUROPEAN SERIES

ISO N°	Passo Pitch P mm	Diam. rullo max. Max roller diam. Dr mm	Largh. int. min. Width between plates R mm	Diam. perno max Max pin diam. Dp mm	Altezza piastra max Inner plate depth Y mm	Largh. catena ribad. max Width over connecting pins Z mm	Ingombro catena max Width over bearing pins F mm	Superf. di lavoro Working surface mm ²	Carico di rottura medio Medium breaking load N	Peso approx. Approx. weight Kg/m	
03 B-1	P5	5,00	3,2	2,5	1,49	4,1	7,4	9,9	6	2.100	0,08
04 B-1	P6	6,00	4,00	2,8	1,85	5,00	7,4	9,9	8	2.950	0,14
05 B-1	P8	8,00	5,00	3,00	2,31	7,11	8,3	13	11	4.650	0,16
* 06 B-1	3/8	9,525	6,35	5,72	3,28	8,26	12,8	19	28	9.310	0,39
08 B-1	1/2	12,70	8,51	7,75	4,45	11,81	16,5	24	50	17.670	0,69
10 B-1	5/8	15,875	10,16	9,65	5,08	14,73	19,1	27	69	23.275	0,88
12 B-1	3/4	19,05	12,07	11,68	5,72	16,13	22,5	30	89	27.930	1,21
16 B-1	1"	25,40	15,88	17,02	8,28	21,08	34,6	46	210	60.180	2,62
20 B-1	1"1/4	31,75	19,05	19,56	10,19	26,42	41,2	50	295	93.650	3,39
24 B-1	1"1/2	38,10	25,40	25,40	14,63	33,40	53,4	65	550	158.500	6,62
28 B-1	1"3/4	44,45	27,94	30,99	15,90	37,08	65,1	78	740	197.000	8,40
32 B-1	2"	50,80	29,21	30,99	17,81	42,29	65,0	78	810	265.300	9,00
-	2"1/4	57,15	34,30	34,30	20,51	50,50	73,8	87	1040	302.500	13,50
40 B-1	2"1/2	63,50	39,37	38,10	22,89	52,96	79,9	102	1290	378.000	15,15
48 B-1	3"	76,20	48,26	45,72	29,24	63,88	99,0	116	2050	559.000	24,65

SERIE AMERICANA / AMERICAN SERIES

ASA N°	ISO N°	Passo Pitch P mm	Diam. rullo max. Max roller diam. Dr mm	Largh. int. min. Width between plates R mm	Diam. perno max Max pin diam. Dp mm	Altezza piastra max Inner plate depth Y mm	Largh. catena ribad. max Width over connecting pins Z mm	Ingombro catena max Width over bearing pins F mm	Superf. di lavoro Working surface mm ²	Carico di rottura medio Medium breaking load N	Peso approx. Approx. weight Kg/m
25-1	04C-1	6,35	3,30	3,18	2,31	6,02	8,3	13	11	3.895	0,13
□ 35-1	06C-1	9,525	5,08	4,77	3,58	9,05	12,5	17	27	9.310	0,33
□ 40-1	08A-1	12,70	7,95	7,85	3,98	12,07	16,5	23	44	16.300	0,60
50-1	10A-1	15,875	10,16	9,40	5,09	15,09	20,5	28	70	24.700	1,01
60-1	12A-1	19,05	11,91	12,57	5,96	18,08	25,8	33	105	35.400	1,43
80-1	16A-1	25,40	15,88	15,75	7,94	24,13	33,5	40	180	61.500	2,57
100-1	20A-1	31,75	19,05	18,90	9,54	30,18	40,2	48	260	101.000	3,87
120-1	24A-1	38,10	22,23	25,22	11,11	36,20	50,4	60	390	144.500	5,65
140-1	28A-1	44,45	25,40	25,22	12,71	42,24	54,2	65	470	194.100	7,44
160-1	32A-1	50,80	28,58	31,55	14,29	48,26	64,5	77	645	245.000	9,74
200-1	40A-1	63,50	39,68	37,85	19,85	60,33	78,3	94	1.090	402.000	16,00
240-1	48A-1	76,20	47,63	47,35	23,81	72,39	95,5	115	1.610	552.000	24,00

* CON PIASTRE A PROFILO DIRITTO / STRAIGHT SIDE PLATES

□ CATENE A BUSSOLA / BUSH CHAINS

TRASPORTO LEGGERO / LIGHT TRANSPORT

**CATENE A RULLI DOPPIE
DOUBLE STRAND ROLLER CHAINS**

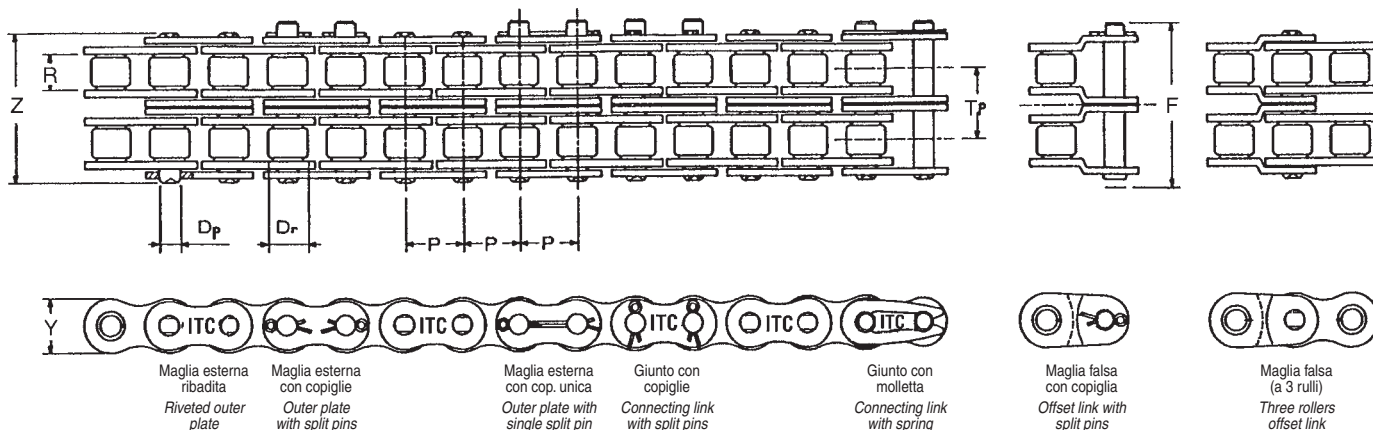

SERIE EUROPEA / EUROPEAN SERIES

ISO N°	Passo Pitch	Diam. rullo max. Max roller diam. Dr mm	Largh. Int. min. Width between plates R mm	Diam. perno max Max pin diam. Dp mm	Altezza piastra max Inner plate depth Y mm	Passo trasv. Transverse pitch Tp mm	Largh. catena ribad. max Width over connecting pins Z mm	Ingombro catena max Max width over bearing pins F mm	Superf. di lavoro Working surface mm²	Carico di rottura medio Medium breaking load N	Peso approx. Approx. weight Kg/m
	P mm										
04 B-2	6,00	4,00	2,8	1,85	5,0	5,5	13,3	16,2	14	5.800	0,23
05 B-2	8,00	5,00	3,00	2,31	7,11	5,64	14,0	20,2	21	8.600	0,31
* 06 B-2	9,525	6,35	5,72	3,28	8,26	10,24	22,9	29,5	56	18.650	0,74
08 B-2	12,70	8,51	7,75	4,45	11,81	13,92	30,4	38,2	100	35.100	1,36
10 B-2	15,875	10,16	9,65	5,08	14,73	16,59	35,8	44,0	137	49.000	1,73
12 B-2	19,05	12,07	11,68	5,72	16,13	19,46	42,0	51,2	178	66.000	2,40
16 B-2	25,40	15,88	17,02	8,28	21,08	31,88	68,0	78,8	420	127.500	5,21
20 B-2	31,75	19,05	19,56	10,19	26,42	36,45	78,5	90,7	590	190.000	6,73
24 B-2	38,10	25,40	25,40	14,63	33,40	48,36	101,8	115,0	1.100	299.000	13,18
28 B-2	44,45	27,94	30,99	15,90	37,08	59,56	124,7	139,5	1.480	414.500	16,74
32 B-2	50,80	29,21	30,99	17,81	42,29	58,55	125,0	140,8	1.620	558.000	17,93
40 B-2	63,50	39,37	38,10	22,89	52,96	72,29	153,5	173,9	2.580	805.000	30,23
48 B-2	76,20	48,26	45,72	29,24	63,88	91,21	190,4	211,4	4.100	1.177.000	49,22

SERIE AMERICANA / AMERICAN SERIES

ASA N°	ISO N°	Passo Pitch P mm	Diam. rullo max. Max roller diam. Dr mm	Largh. Int. min. Width between plates R mm	Diam. perno max Max pin diam. Dp mm	Altezza piastra max Inner plate depth Y mm	Passo trasv. Transverse pitch Tp mm	Largh. catena ribad. max Width over connecting pins Z mm	Ingombro catena max Max width over bearing pins F mm	Superf. di lavoro Working surface mm²	Carico di rottura medio Medium breaking load N	Peso approx. Approx. weight Kg/m
□ 25-2	04C-2	6,35	3,30	3,18	2,31	6,02	6,40	14,6	19,4	22	8.200	0,25
□ 35-2	06C-2	9,525	5,08	4,77	3,58	9,05	10,13	22,1	28,7	53	19.600	0,66
40-2	08A-2	12,70	7,95	7,85	3,98	12,07	14,38	30,9	38,6	88	34.300	1,20
50-2	10A-2	15,875	10,16	9,40	5,09	15,09	18,11	38,4	46,6	140	52.000	2,00
60-2	12A-2	19,05	11,91	12,57	5,96	18,08	22,70	48,8	58,0	210	74.500	2,84
80-2	16A-2	25,40	15,88	15,75	7,94	24,13	29,29	62,7	73,5	360	129.400	5,09
100-2	20A-2	31,75	19,05	18,90	9,54	30,18	35,76	76,5	88,7	520	211.800	7,68
120-2	24A-2	38,10	22,23	25,22	11,11	36,20	45,44	96,0	109,2	780	302.000	11,22
140-2	28A-2	44,45	25,40	25,22	12,71	42,24	48,87	103,5	118,3	940	407.900	14,74
160-2	32A-2	50,80	28,58	31,55	14,29	48,26	58,55	123,5	139,3	1.290	513.800	19,31
200-2	40A-2	63,50	39,68	37,85	19,85	60,33	71,55	150,4	170,8	2.180	843.200	31,76
240-2	48A-2	76,20	47,63	47,35	23,81	72,39	87,83	183,4	204,4	3.220	1.157.100	47,70

* CON PIASTRE A PROFILO DIRITTO / STRAIGHT SIDE PLATES

□ CATENE A BUSSOLA / BUSH CHAIN

TRASPORTO LEGGERO / LIGHT TRANSPORT

**CATENE A RULLI TRIPLE
TRIPLE STRAND ROLLER CHAINS**

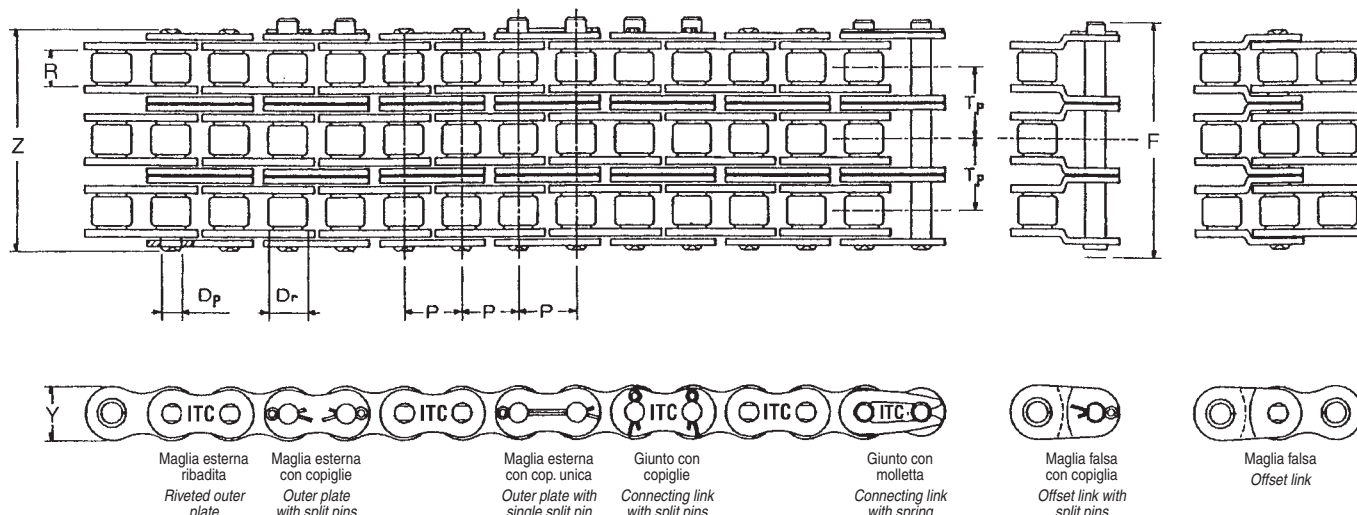

SERIE EUROPEA / EUROPEAN SERIES

ISO N°	Passo Pitch P mm	Diam. rullo max. Max roller diam. Dr mm	Largh. int. min. Width between plates R mm	Diam. perno max Max pin diam. Dp mm	Altezza piastra max Inner plate depth Y mm	Passo trasv. Transverse pitch Tp mm	Largh. catena ribad. max Width over connecting pins Z mm	Ingombro catena max Max width over bearing pins F mm	Superf. di lavoro Working surface mm ²	Carico di rottura medio Medium breaking load N	Peso approx. Approx. weight Kg/m
05 B-3	8,00	5,00	3,00	2,31	7,11	5,64	19,9	23,0	32	10.200	0,53
* 06 B-3	9,525	6,35	5,72	3,28	8,26	10,24	33,2	39,8	84	26.450	1,13
08 B-3	12,70	8,51	7,75	4,45	11,81	13,92	44,3	52,1	156	51.950	2,05
10 B-3	15,875	10,16	9,65	5,08	14,73	16,59	52,3	60,5	206	73.550	2,60
12 B-3	19,05	12,07	11,68	5,72	16,13	19,46	61,5	70,7	267	88.250	3,59
16 B-3	25,40	15,88	17,02	8,28	21,08	31,88	99,9	110,7	630	176.500	7,80
20 B-3	31,75	19,05	19,56	10,19	26,42	36,45	115,0	127,2	885	284.700	10,07
24 B-3	38,10	25,40	25,40	14,63	33,40	48,36	150,2	163,2	1.650	439.250	19,74
28 B-3	44,45	27,94	30,99	15,90	37,08	59,56	184,3	199,1	2.220	558.950	25,08
32 B-3	50,80	29,21	30,99	17,81	42,29	58,55	183,0	198,8	2.430	750.500	26,86
40 B-3	63,50	39,37	38,10	22,89	52,96	72,29	226,0	246,4	3.870	1.147.350	45,13
48 B-3	76,20	48,26	45,72	29,24	63,88	91,21	281,6	302,6	6.150	1.765.150	73,79

SERIE AMERICANA / AMERICAN SERIES

ASA N°	ISO N°	Passo Pitch P mm	Diam. rullo max. Max roller diam. Dr mm	Largh. int. min. Width between plates R mm	Diam. perno max Max pin diam. Dp mm	Altezza piastra max Inner plate depth Y mm	Passo trasv. Transverse pitch Tp mm	Largh. catena ribad. max Width over connecting pins Z mm	Ingombro catena max Max width over bearing pins F mm	Superf. di lavoro Working surface mm ²	Carico di rottura medio Medium breaking load N	Peso approx. Approx. weight Kg/m
□ 35-3	06C-3	9,525	5,08	4,77	3,58	9,05	10,13	32,2	38,9	80	29.400	0,99
40-3	08A-3	12,70	7,95	7,85	3,98	12,07	14,38	45,3	53,1	132	51.450	1,80
50-3	10A-3	15,875	10,16	9,40	5,09	15,09	18,11	56,4	64,5	210	78.000	3,00
60-3	12A-3	19,05	11,91	12,57	5,96	18,08	22,70	71,7	80,8	315	111.800	4,25
80-3	16A-3	25,40	15,88	15,75	7,94	24,13	29,29	91,7	102,5	540	194.150	7,61
100-3	20A-3	31,75	19,05	18,90	9,54	30,18	35,76	112,5	124,7	780	317.750	11,49
120-3	24A-3	38,10	22,23	25,22	11,11	36,20	45,44	141,7	154,9	1.170	453.100	16,79
140-3	28A-3	44,45	25,40	25,22	12,71	42,24	48,87	152,4	167,2	1.410	611.900	22,04
160-3	32A-3	50,80	28,58	31,55	14,29	48,26	58,55	182,5	198,3	1.935	770.800	28,88
200-3	40A-3	63,50	39,68	37,85	19,85	60,33	71,55	222,5	242,9	3.270	1.265.000	47,52
240-3	48A-3	76,20	47,63	47,35	23,81	72,39	87,83	271,3	292,3	4.830	1.735.750	71,40

* CON PIASTRE A PROFILO DIRITTO / STRAIGHT SIDE PLATES

□ CATENE A BUSSOLA / BUSH CHAINS

TRASPORTO LEGGERO / LIGHT TRANSPORT

CATENE A RULLI ROLLER CHAINS

CATENE PER BICICLETTE E CICLOMOTORI
CHAINS FOR BICYCLES AND MOTOR CYCLES

Nota: Tutte le dimensioni indicate, sono espresse in mm.
Note: All dimensions are expressed in mm.

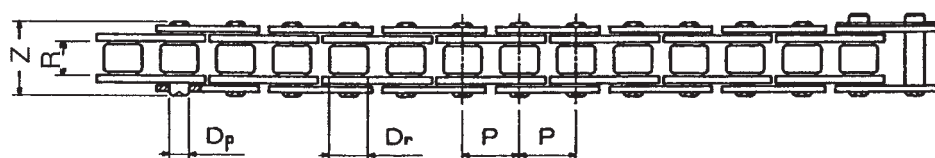

Maglia esterna
ribadita
Riveted outer
plate



Giunto con
molletta
Connecting link
with spring clip



Maglia falsa
(a 3 rulli)
3 rollers
offset link

APPELLATIVO TYPE	ISO N°	Passo Pitch	Diam. rullo max. Max roller diam.	Largh. int. min. Width between plates	Diam. perno max Max pin diam.	Altezza piastra max Inner plate depth	Largh. catena ribad. max Width over connecting pins	Ingombro catena max Width over bearing pins	Superf. di lavoro Working surface	Carico di rottura medio Medium breaking load	Peso approx Approx. weight
		P mm	Dr mm	R mm	Dp mm	Y mm	Z mm	F mm	mm ²	N	Kg/m
1/2x3/32	082	12,70	7,75	2,38	3,66	9,91	8,1	10,6	16	9.410	0,26
1/2x1/8	081	12,70	7,75	3,30	3,68	9,91	9,31	12,3	20	9.410	0,29
1/2x3/16	083	12,70	7,75	4,88	4,09	10,30	12,9	15,9	33	11.365	0,43
1/2x3/16 RINF.	084	12,70	7,75	4,88	4,09	11,15	14,6	17,6	36	15.100	0,51
1/2x1/4 (ASA 41)	085	12,70	7,75	6,25	3,58	9,91	13,7	17,7	32	11.360	0,47
	-	12,70	8,51	5,21	4,45	11,81	14,5	22	40	17.900	0,60
	-	15,875	10,16	6,48	5,08	14,73	17,5	26	54	23.565	0,80

TRASPORTO LEGGERO / LIGHT TRANSPORT

CATENE A RULLI, PER CURVE (serie SIDE BOW) (SIDE BOW series) ROLLER CHAINS

Si tratta di catene a rulli; snodabili nei piani verticale ed orizzontale.

Comunemente utilizzate come catene per trasporto, nel caso si debbano eseguire particolari percorsi curvilinei, fino a raggiungere curve di 180°, od anche, per la motorizzazione di rulli per trasportatori con tappeti a percorso curvilineo.

Su richiesta, si possono fornire catene con attacchi speciali.

These are untied roller chains on both vertical and horizontal surface. Normally used as chains for transport and especially requested when curvilinear ways are present, these chains can reach 180° curves.

They are also suitable for the motorization of rollers for conveyors with curvilinear way.

Under request, chains with special attachments can be supplied.

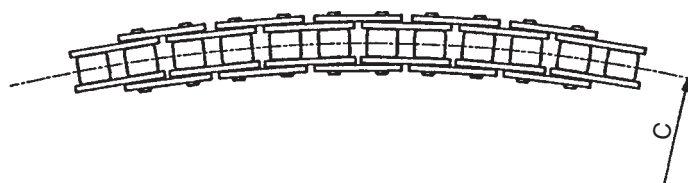
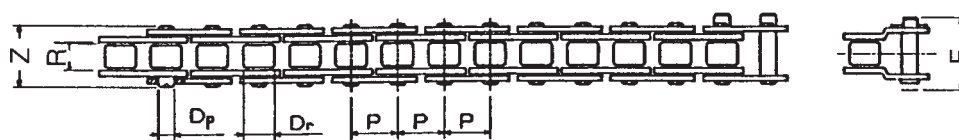

TIPO DI CATENA TYPE OF CHAIN	Carico rottura Breaking load kg. ca.	Peso per metro Weight per mt. kg. ca.	P	R	Dr	F	Raggio minimo di curvatura Min. radius of curvature C
			millimetri / mm				
ASA 35 SB	820	0,30	9,525 = 3/8"	4,9	5,08	17	255
ASA 40 SB	1100	0,60	12,7 = 1/2"	7,95	7,95	23	360
ASA 50 SB	2100	1,00	15,875 = 5/8"	9,5	10,16	28	410
ASA 60 SB	2750	1,40	19,05 = 3/4"	12,7	11,9	33	550
ASA 80 SB	6100	2,40	25,4 = 1"	15,88	15,88	35,5	915
C 2050 SB	2100	0,70	31,75 = 1 1/4"	9,5	10,16	28	770

TRASPORTO LEGGERO / LIGHT TRANSPORT

CATENE A RULLI, CON O-RING ROLLER CHAINS WITH O-RING

Negli impieghi critici, laddove la lubrificazione richiesta è di vitale importanza, il sistema di sigillatura delle parti sottoposte ad usura, fra perni e bussola, è salvaguardato dall'adozione della guarnizione ad anello "O-Ring". Tale applicazione si rende necessaria nel caso in cui, non sia possibile attivare la lubrificazione tradizionale.

Where uses are critic and lubrication is very important, the sealing system of the parts under wear and tear (between pins and sleeve) is protected by using the "O-Ring" seal. This application is necessary when the traditional lubrication cannot be performed.

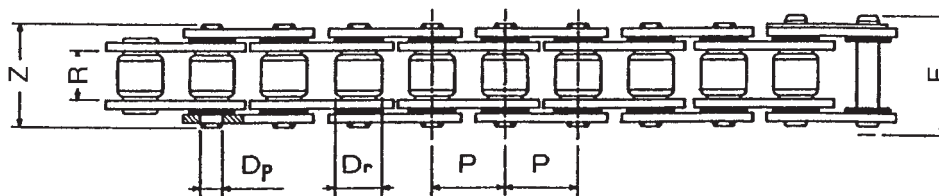
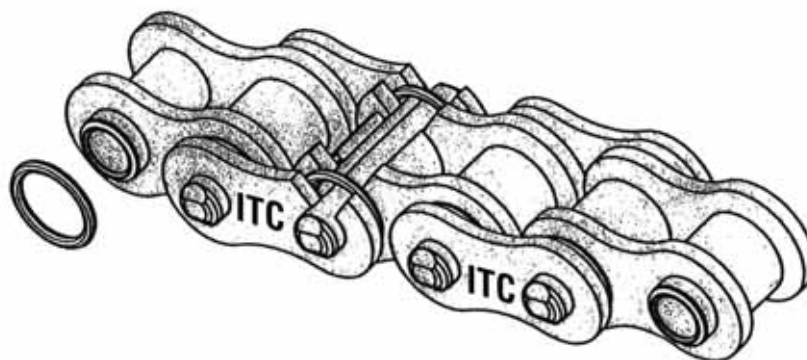

Maglia esterna
ribadita
Riveted outer
plate

Giunto con
molletta
Connecting link
with spring

ISO N°	Passo Pitch P mm	Diam. rullo max. Max roller diam. Dr mm	Largh. int. min. Width between plates R mm	Diam. perno max Max pin diam. Dp mm	Altezza piastra max Inner plate depth Y mm	Largh. catena ribad. max Width over connecting pins Z mm	Ingombro catena max Width over bearing pins F mm	Superf. di lavoro Working surface mm ²	Carico di rottura medio Medium breaking load N	Peso approx Approx. weight Kg/m
1/2' OR	12,70	8,51	7,75	4,45	12,00	20,30	24	52	21.150	0,79
5/8' OR	15,875	10,16	6,48	5,31	14,90	21,20	25	74	30.200	1,12
5/8' OR	15,875	10,16	9,65	5,31	14,90	24,50	28	90	30.200	1,22
3/4' OR	19,05	11,91	12,58	5,96	18,08	27,60	34	118	35.750	1,58

AISI 304 L

GRADO DI RESISTENZA ALLA CORROSIONE

CORROSION RESISTANCE GUIDE

AGENTE CORROSIVO CORROSIVE AGENT	CONCENTRAZIONE CONCENTRATION %	TEMPERATURA TEMPERATURE °C	304 L
ACETO / VINEGAR		20	A
ACIDO ACETICO / ACETIC ACID	5-100	20	A
ACIDO BUTIRRICO / BUTYRIC ACID	50	Bollente / Boiling	C
ACIDO CITRICO / CITRIC ACID	5-10	20-65	A
ACIDO CROMICO / CHROMIC ACID	5	20-65	A
ACIDO CLORIDRICO / HYDROCHLORIC ACID	15	Bollente / Boiling	A
ACIDO FORMICO / FORMIC ACID	5	20	E
ACIDO FOSFORICO / PHOSPHORIC ACID	10	20	A
	10	Bollente / Boiling	C
ACIDO LATTICO / LACTIC ACID	10	20	A
	10	50	B
	1	20	A
	5-10	20	C
	5	20	A
	5	65	B
	10	20	A
	10	Bollente / Boiling	B
	5-50	20	A
ACIDO NITRICO / NITRIC ACID	50	Bollente / Boiling	A
	100	Bollente / Boiling	D
ACIDO OLEICO / OLEIC ACID	100	20	B
	5	20	A
	5	Bollente / Boiling	E
ACIDO SOLFORICO / SULPHURIC ACID	50	20	D
	50	Bollente / Boiling	E
	100	20	A
	100	Bollente / Boiling	D
ACIDO TARTARICO / TARTAR ACID	10	20-65	A
ACQUA DOLCE / WATER			A
ACQUA MARINA / SEA WATER			A
ALCOOL ETILICO / ETHYL ALCOHOL		20 - Bollente / Boiling	A
ALCOOL METILICO / METHYL ALCOHOL		20	A
AMMONIACA / ACQUA AMMONIA		65	C
		20	A
BENZINA / GASOLINE		20	A
BIRRA / BEER			A
CAFFÈ / COFFEE		Bollente / Boiling	A
CARBONATO DI SODIO / SODIUM CARBONATE	5	20-65	A
CLOROFORMIO / CHLOROFORM		20	A
CLORURO FERRICO / FERRIC CHLORIDE	1	20	B
	5	20	D
CLORURO DI SODIO / SODIUM CHLORIDE	5-20	20-65	A
CLORURO DI ZINCO / ZINC CHLORIDE	5	20	A
GELATINA / GELATINE			A
GLICERINA / GLYCERINE			A
IDROSSIDO DI CALCIO / HYDROXIDE CALCIUM	10-20	Bollente / Boiling	A
	50	Bollente / Boiling	C
KETCHUP / KETTCHUP		20	A
LATTE / MILK		65	A
MAYONNAISE / MAYONNAISE		20	A
SAPONE / SOAP		20	A
SCIROPPO / SYRUP			A
SOLFATO DI ZINCO / ZINC SULPHATE	5-100	20	A
SUCCHI DI FRUTTA / FRUIT JUICE			A
TISOLFATO DI SODIO / SODIUM THIOSULFATE	5-10	20-65	A
TRICLOROETILENE / TRICHLOROETHYLENE	100	20	C
VERNICI / PAINT			A
VINO / WINE			A
WHISKY / WHISKY			A
ZUCCHERO DI CANNA / CANE SUGAR			A

A: ECCELLENTE / EXCELLENT (Corrosion Rate below 0.0089 mm/month)

B: SODDISFACENTE / SATISFACTORY (Corrosion Rate 0.0089-0.089 mm/month)

C: MARGINALE / MARGINALE (Corrosion Rate 0.089-0.25 mm/month)

D: INSODDISFACENTE / UNSATISFACTORY (Corrosion Rate 0.25-0.89 mm/month)

E: NON RACCOMANDABILE / NOT RECOMMENDABLE (Corrosion Rate over 0.89 mm/month)

CATENE A RULLI IN ACCIAIO "INOX AISI 304" "AISI 304" STAINLESS STEEL ROLLER CHAINS

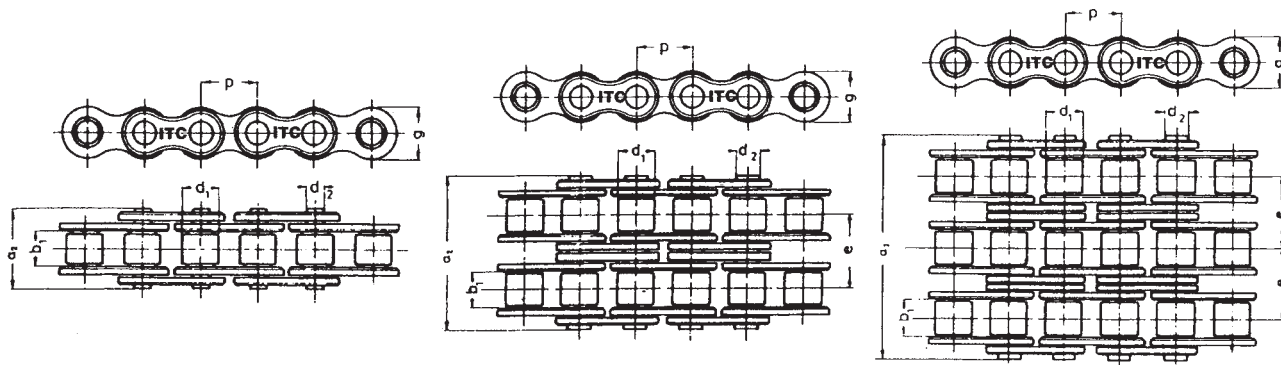

CATENA A RULLI SEMPLICE - DIN 8187 "AISI 304" SINGLE STRAND ROLLER CHAIN - DIN 8187 "AISI 304"

ISO N°	p		b1 mm min.	d2 mm	d1 mm max.	a2 mm max.	g mm max.	F _B min N	q kg/m ≈
	mm	inch							
05B-1	8	-	3,00	2,31	5,00	8,6	7,11	2.400	0,18
06B-1	9,525	3/8"	5,72	3,28	6,35	13,5	8,26	6.000	0,41
08B-1	12,7	1/2"	7,75	4,45	8,51	17,0	11,81	10.000	0,70
10B-1	15,875	5/8"	9,65	5,08	10,16	19,6	14,73	13.000	0,95
12B-1	19,05	3/4"	11,68	5,72	12,07	22,7	16,13	17.000	1,25
16B-1	25,4	1"	17,02	8,28	15,88	36,1	21,08	37.000	2,70

CATENA A RULLI DOPPIA - DIN 8187 "AISI 304" DOUBLE STRAND ROLLER CHAIN - DIN 8187 "AISI 304"

ISO N°	p		b1 mm min.	d2 mm	d1 mm max.	a2 mm max.	g mm max.	e mm	F _B min N	q kg/m ≈
	mm	inch								
06B-2	9,525	3/8"	5,72	3,28	6,35	23,8	8,26	10,24	10.000	0,78
08B-2	12,7	1/2"	7,75	4,45	8,51	31,0	11,81	13,92	20.000	1,35
10B-2	15,875	5/8"	9,65	5,08	10,16	36,2	14,73	16,59	24.000	1,85
12B-2	19,05	3/4"	11,68	5,72	12,07	42,2	16,13	19,46	31.000	2,50
16B-2	25,4	1"	17,02	8,28	15,88	68,0	21,08	31,88	68.000	5,40

CATENA A RULLI TRIPLA - DIN 8187 "AISI 304" TRIPLE STRAND ROLLER CHAIN - DIN 8187 "AISI 304"

ISO N°	p		b1 mm min.	d2 mm	d1 mm max.	a2 mm max.	g mm max.	e mm	F _B min N	q kg/m ≈
	mm	inch								
06B-3	9,525	3/8"	5,72	3,28	6,35	34,0	8,26	10,24	14.000	1,2
08B-3	12,7	1/2"	7,75	4,45	8,51	44,9	11,81	13,92	30.000	2,0
10B-3	15,875	5/8"	9,65	5,08	10,16	52,8	14,73	16,59	38.000	2,8
12B-3	19,05	3/4"	11,68	5,72	12,07	61,7	16,13	19,46	52.000	3,8
16B-3	25,4	1"	17,02	8,28	15,88	99,9	21,08	31,88	99.000	8,0

CATENA A RULLI SEMPLICI - DIN 8188 "AISI" ASA "AISI 304" SINGLE STRAND ROLLER CHAIN - DIN 8188 "AISI" ASA "AISI 304"

ASA N°	p		b1 mm min.	d2 mm	d1 mm max.	a2 mm max.	g mm max.	F _B min N	q kg/m ≈
	mm	inch							
40-1	12,7	1/2"	7,95	3,96	7,92	17,8	12,07	10.000	0,61
50-1	15,875	5/8"	9,53	5,08	10,16	21,8	15,09	14.000	1,01
60-1	19,05	3/4"	12,70	5,94	11,91	26,9	18,08	19.000	1,47
80-1	25,4	1"	15,88	7,92	15,88	33,5	24,13	37.000	2,57

TRASPORTO LEGGERO / LIGHT TRANSPORT

CATENE A RULLI, CON TRATTAMENTO DI NICHELATURA SUPERFICIALE

ROLLER CHAINS, WITH SUPERFICIAL NICHEL-PLATED TREATMENT

Trattasi di catene trattate superficialmente e con caratteristiche di resistenza all'ossidazione ed alla corrosione, assai vicine, come efficacia, alla qualità delle catene INOX, rispetto alle quali però, presentano carichi di rottura e di lavoro, assai più elevate, uguali, per resistenza, a quelle in acciaio legato e/o al carbonio. Dette catene, sono da impiegarsi in condizioni ambientali assai difficili, in presenza di agenti aggressivi, e nei casi in cui, la sollecitazione alla resistenza ad attacchi di liquidi ed acidi, renda necessaria una protezione superficiale dei componenti, pur non alterandone le connotazioni tecno-mecchaniche.

These chains are superficially treated to increase their resistance to corrosion and oxidation, becoming in this way very similar to stainless steel types. The most important difference from those is their greater capacity of standing higher breaking load and loads, quality that usually belong to steel and/or carbon chains. These chains are usually assembled in very difficult working conditions, where aggressive agents are present or when the resistance against acids and liquids involves a superficial protection of components (techno-mechanics characteristics do not change).

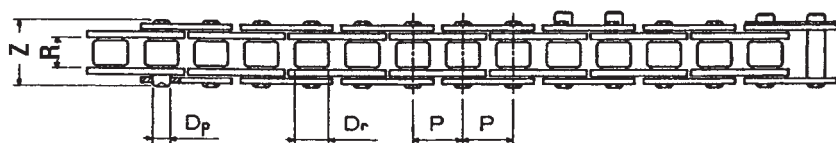

Maglia esterna ribadita
Riveted outer plate

Giunto con copiglie
Connecting link with split pins

Giunto con molletta
Connecting link with spring clip



Maglia falsa con copiglia
Offset link with split pins



Maglia falsa (a 3 rulli)
Three rollers offset link

SERIE EUROPEA / EUROPEAN SERIES

ISO N°	Passo Pitch	Diam. rullo max. Max roller diam.	Largh. Int. min. Width between plates	Diam. perno max Max pin diam.	Altezza piastra max Inner plate depth	Largh. catena ribad. max Width over connecting pins	Ingombro catena max Width over bearing pins	Superf. di lavoro Working surface	Carico di rottura medio Medium breaking load	Peso approx. Approx. weight
	P mm	Dr mm	R mm	Dp mm	Y mm	Z mm	F mm	mm ²	N	Kg/m
06B-1	9,525	6,35	5,72	3,28	8,26	12,8	19	28	9.500	0,39
08B-1	12,70	8,51	7,75	4,45	11,81	16,5	24	50	17.950	0,69
10B-1	15,875	10,16	9,65	5,08	14,73	19,1	27	69	22.900	0,88
12B-1	19,05	12,07	11,68	5,72	16,13	22,5	30	89	27.000	1,21
16B-1	25,40	15,88	17,02	8,28	21,08	34,6	46	210	61.000	2,62

TRASPORTO LEGGERO / LIGHT TRANSPORT

CATENE A RULLI, CON PIASTRE A PROFILO DIRITTO
ROLLER CHAINS WITH STRAIGHT SIDE PLATES

Particolarmente adatte all'utilizzo in applicazioni, laddove si renda necessario trasportare scatole, o cartonati in genere, pallets.
 Dette catene, scorrendo sulle piastre, strisciando, evitano eventuali danneggiamenti alle parti a contatto con essa, dei colli trasportati.

Particularly suitable for pallets, boxes and cardboards transports.
These chains slide on plates, avoiding therefore possible damages of transported packages.

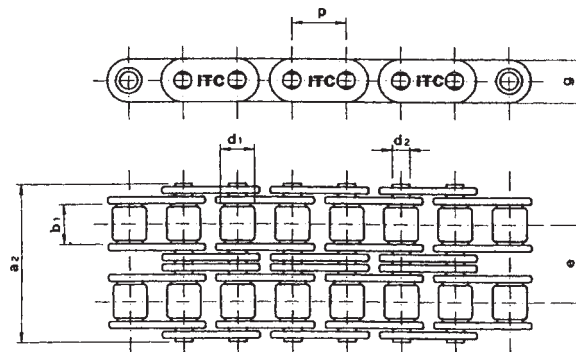
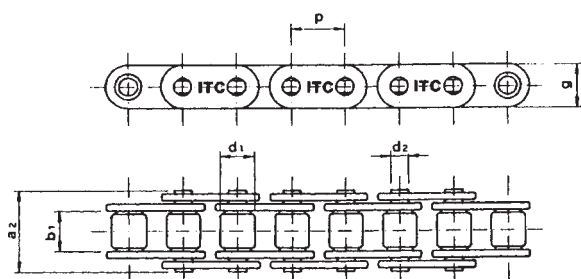

CATENA A RULLI SEMPLICE - DIN 8187
SINGLE STRAND ROLLER CHAIN - DIN 8187

ISO N°	p		b1 mm min.	d2 mm	d1 mm max.	a2 mm max.	g mm max.	F _B min N	q kg/m ≈
	mm	inch							
08B-1	12,7	1/2"	7,75	4,45	8,51	17	11,5	18.900	0,78
10B-1	15,875	5/8"	9,65	5,08	10,16	19,6	13,9	22.700	1,03
12B-1	19,05	3/4"	11,68	5,72	12,07	22,7	16,1	29.500	1,30
16B-1	25,4	1"	17,02	8,28	15,88	36,1	21	58.000	2,90
20B-1	31,75	1" 1/4"	19,59	10,19	19,05	43,2	26,2	95.000	4,15

CATENA A RULLI DOPPIA - DIN 8187
DOUBLE STRAND ROLLER CHAIN - DIN 8187

ISO N°	p		b1 mm min.	d2 mm	d1 mm max.	a2 mm max.	g mm max.	e mm	F _B min N	q kg/m ≈
	mm	inch								
10B-2	15,875	5/8"	9,65	5,08	10,16	36,2	13,9	16,59	45.400	1,95
12B-2	19,05	3/4"	11,68	5,72	12,07	42,2	16,1	19,46	59.000	2,60
16B-2	25,4	1"	17,02	8,28	15,88	68,0	21,0	31,88	110.000	5,70
20B-2	31,75	1" 1/4"	19,59	10,19	19,05	79,7	26,2	35,45	180.000	7,80

TRASPORTO LEGGERO / LIGHT TRANSPORT

ATTACCHI "ED" PER CATENE A RULLI SEMPLICI

"ED" ATTACHMENTS FOR SINGLE STRAND ROLLER CHAINS

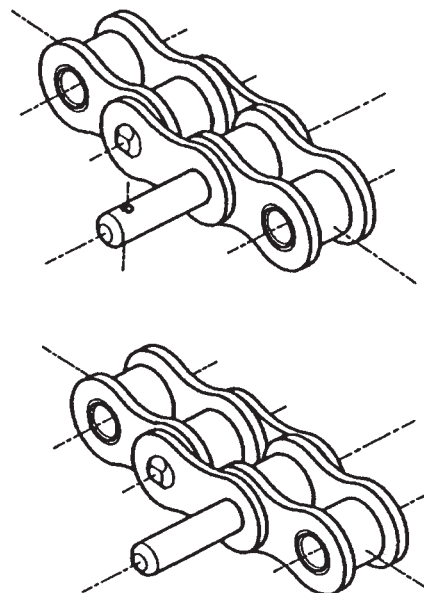
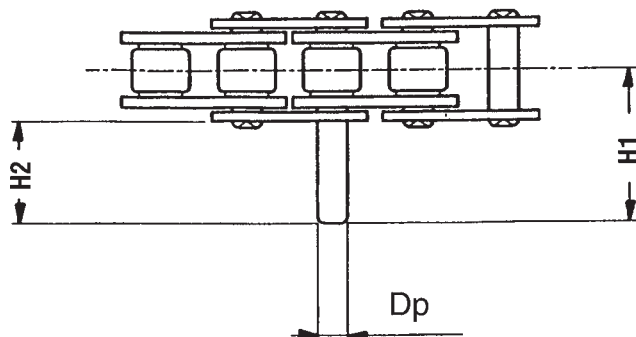
SERIE EUROPEA / EUROPEAN SERIES

ISO N°	Passo Pitch P mm	Diam. perno max Max pin diam. Dp mm	H2 mm	H1 mm
06B *	9,525	3,28	11,0	16,5
08B	12,70	4,45	14,9	22,1
10B	15,875	5,08	17,5	26,1
12B	19,05	5,72	20,7	30,5
16B	25,40	8,28	33,9	49,9

SERIE AMERICANA / AMERICAN SERIES

ISO N°	Passo Pitch P mm	Diam. perno max Max pin diam. Dp mm	H2 mm	H1 mm
A 35	9,525	3,58	9,5	14,7
A 40	12,70	3,98	9,5	16,7
A 50	15,875	5,09	11,9	21,0
A 60	19,05	5,96	14,3	25,8
A 80	25,40	7,94	19,0	33,7
A 100	31,75	9,54	23,8	41,7
A 120	38,10	11,11	28,6	51,4
A 140	44,45	12,71	33,0	57,5
A 160	50,80	17,46	38,1	67,4

* CATENA CON PIASTRE A PROFILO DIRITTO / CHAIN WITH STRAIGHT SIDE PLATES

TRASPORTO LEGGERO / LIGHT TRANSPORT

CATENA A RULLI, A PERNI FORATI

ROLLER CHAIN WITH HOLLOW PINS

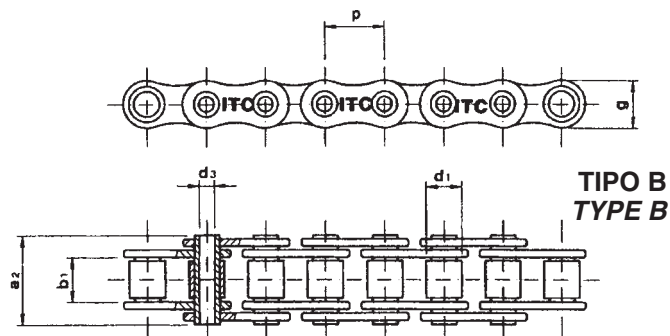
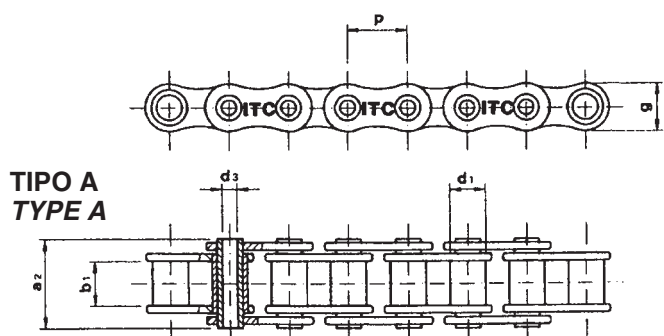

ISO N°	p		b ₁ mm min.	d ₃ mm	d ₁ mm max.	a ₂ mm max.	g mm max.	F _B min N	q kg/m ≈	TIPO TYPE
	mm	inch								
08B-1	12,7	1/2"	7,75	4,5	8,51	16,8	12,2	13.500	0,60	A
10B-1	15,875	5/8"	9,65	5,0	10,16	18,6	14,3	14.500	0,83	A
12B-1	19,05	3/4"	11,68	5,75	12,07	24,0	16,5	18.500	1,05	A
08B-1	12,7	1/2"	7,75	4,40	8,51	17,0	11,7	14.000	0,68	B
10B-1	15,875	5/8"	9,65	5,10	10,16	19,5	14,0	15.000	0,87	B
12B-1	19,05	3/4"	11,68	5,70	12,07	22,5	18,0	21.000	1,10	B
12A-1	19,05	3/4"	12,70	5,97	11,91	25,0	18,0	25.000	1,30	B
16B-1	25,4	1"	17,02	8,10	15,88	36,0	21,0	50.000	2,40	B

TRASPORTO LEGGERO / LIGHT TRANSPORT**CATENE SPECIALI PER MACCHINE TERMOFORMATRICI
SPECIAL CHAINS FOR THERMOFORMING MACHINERIES**

Ideate per il trasporto di films in poliuretano, queste catene (di passo 1/2x5/16), vengono utilizzate nelle macchine per l'imballaggio di prodotti alimentari, riviste, ed imballaggi in genere, laddove venga richiesta la "termo formatura a vuoto".

Di diverso spessore e consistenza può essere il film, o pellicola da trasportare, mentre per quanto concerne i componenti di detta catena, da ricordare che la "catena base" è prevista in Acciaio Nikelato superficialmente, mentre le "pinze" laterali sono previste in Acciaio inossidabile.

Suitable for polyurethan films transport, these chains (their pitch is 1/2x5/16) are utilized in machineries for package of any kind (foods and magazines for example) where "vacuum forming" is required.

The films can have a different thickness or consistence whereas concerning chain components, the "standard chain" has its surface made of nickel-plated steel and its lateral "pliers" made of stainless steel.

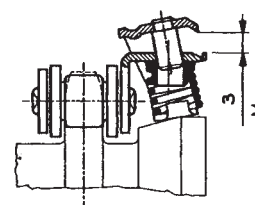
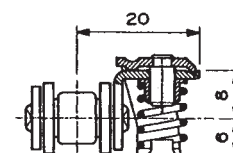
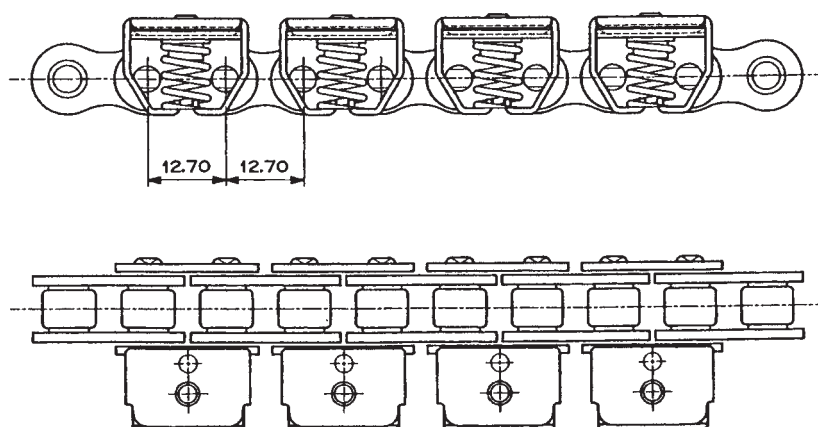
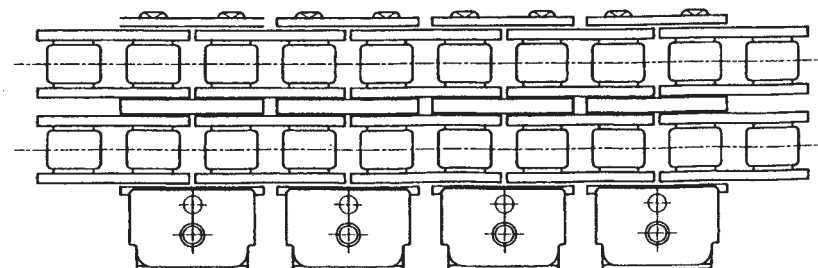
ITC-08B-1 FILM**ITC-08B-2 FILM**

TRASPORTO LEGGERO / LIGHT TRANSPORT

**GLI ATTACCHI STANDARD
STANDARD ATTACHMENTS**

Per catena "ITC" Passo 8 (ISO 05B) - Passo 8 mm.

For "ITC" chain Pitch 8 (ISO 05B) - Pitch 8 mm.

Nota: Tutte le dimensioni indicate, sono espresse in mm.

Note: All dimensions are expressed in mm.

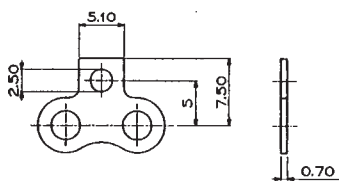
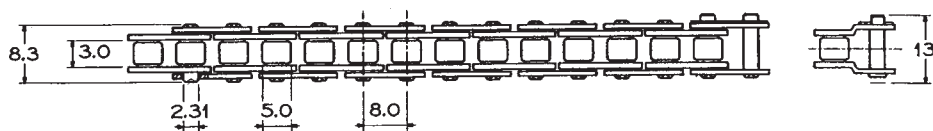

**ATTACCO MAGLIA INTERNA
INNER PLATE ATTACHMENT**

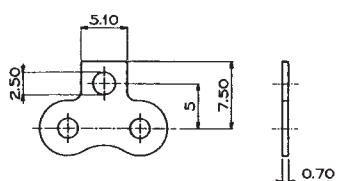

**ATTACCO MAGLIA ESTERNA
OUTER PLATE ATTACHMENT**



EM 35

EM1

TRASPORTO LEGGERO / LIGHT TRANSPORT

**GLI ATTACCHI STANDARD
STANDARD ATTACHMENTS**

Per catena "ITC" 3/8" (ISO 06B) - Passo 9,525 mm.

For "ITC" chain 3/8" (ISO 06B) - Pitch 9,525 mm.

Nota: Tutte le dimensioni indicate, sono espresse in mm.

Note: All dimensions are expressed in mm.

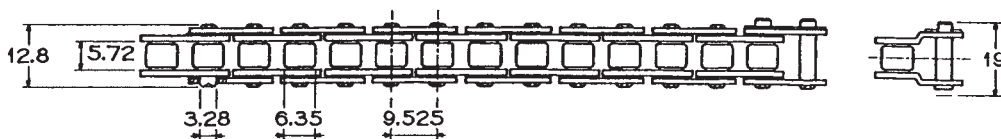

**ATTACCO MAGLIA INTERNA
INNER PLATE ATTACHMENT**

**ATTACCO MAGLIA ESTERNA
OUTER PLATE ATTACHMENT**

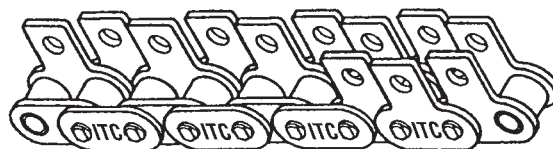

EM 35

EM 1

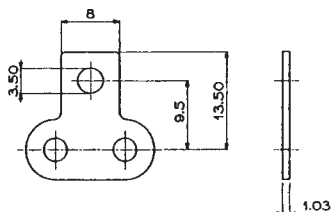
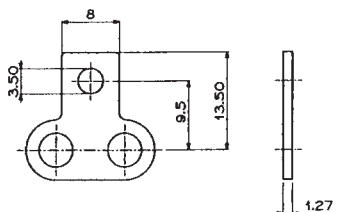

**ATTACCO MAGLIA INTERNA
INNER PLATE ATTACHMENT**

**ATTACCO MAGLIA ESTERNA
OUTER PLATE ATTACHMENT**

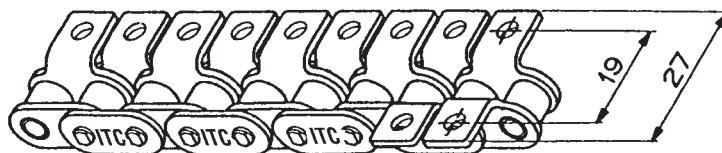

E1

EK1

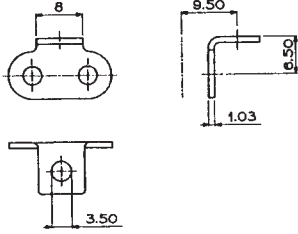
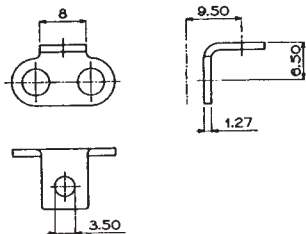

**ATTACCO MAGLIA ESTERNA
OUTER PLATE ATTACHMENT**

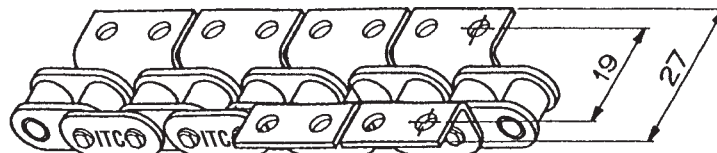

E2

EK2

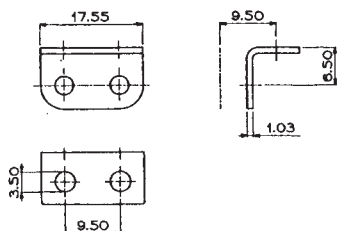

TRASPORTO LEGGERO / LIGHT TRANSPORT

**GLI ATTACCHI STANDARD
STANDARD ATTACHMENTS**

Per catena "ITC" 1/2x5/16" (ISO 08B) - Passo 12,70 mm.

For "ITC" chain 1/2X5/16" (ISO 08B) - Pitch 12,70 mm.

Nota: Tutte le dimensioni indicate, sono espresse in mm.

Note: All dimensions are expressed in mm.

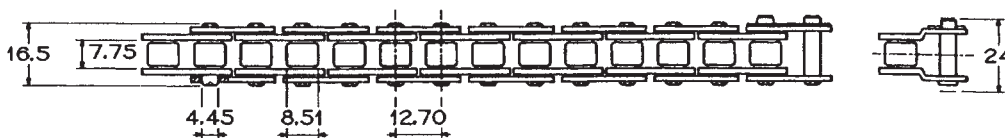

**ATTACCO MAGLIA INTERNA
INNER PLATE ATTACHMENT**

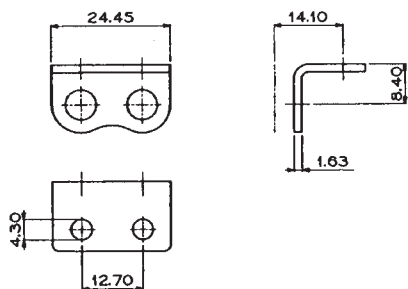

E2

EK2

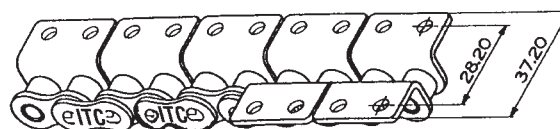

**ATTACCO MAGLIA ESTERNA
OUTER PLATE ATTACHMENT**

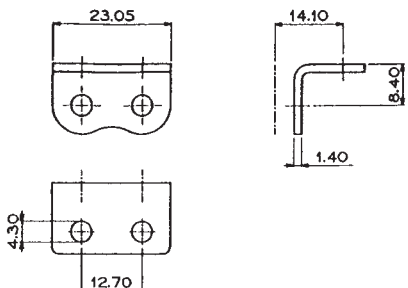

E2

EK2

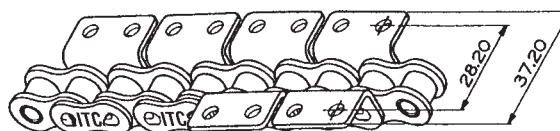

TRASPORTO LEGGERO / LIGHT TRANSPORT

**GLI ATTACCHI STANDARD
STANDARD ATTACHMENTS**

Per catena "ITC" 1/2x5/16" (ISO 08B) - Passo 12,70 mm.

For "ITC" chain 1/2X5/16" (ISO 08B) - Pitch 12,70 mm.

Nota: Tutte le dimensioni indicate, sono espresse in mm.

Note: All dimensions are expressed in mm.

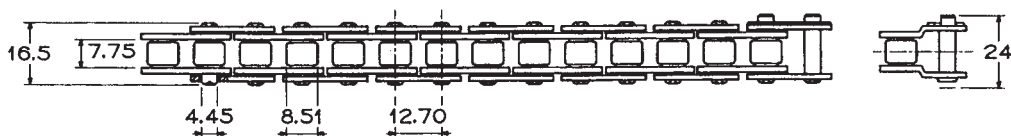

**ATTACCO MAGLIA INTERNA
INNER PLATE ATTACHMENT**



EM35-2

EM2

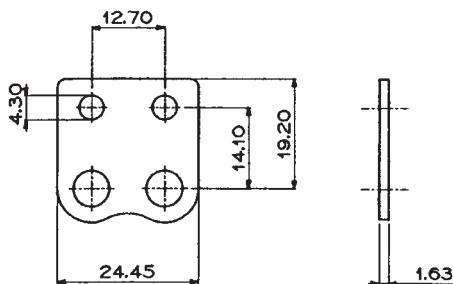

**ATTACCO MAGLIA ESTERNA
OUTER PLATE ATTACHMENT**



EM35-2

EM2

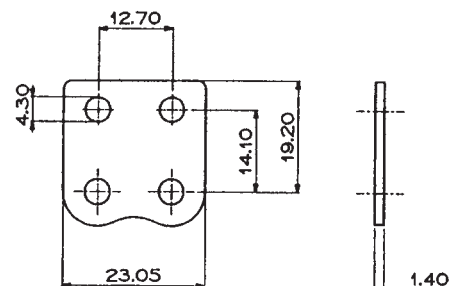

TRASPORTO LEGGERO / LIGHT TRANSPORT

**GLI ATTACCHI STANDARD
STANDARD ATTACHMENTS**

Per catena "ITC" 1/2x5/16" (ISO 08B) - Passo 12,70 mm.

For "ITC" chain 1/2X5/16" (ISO 08B) - Pitch 12,70 mm.

Nota: Tutte le dimensioni indicate, sono espresse in mm.

Note: All dimensions are expressed in mm.

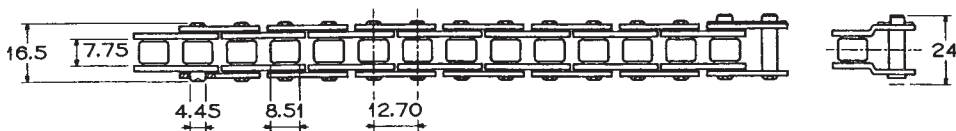

EM35

EM1

ATTACCO MAGLIA INTERNA
INNER PLATE ATTACHMENT

ATTACCO MAGLIA ESTERNA
OUTER PLATE ATTACHMENT

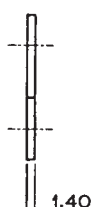
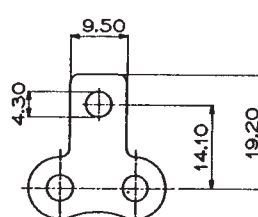
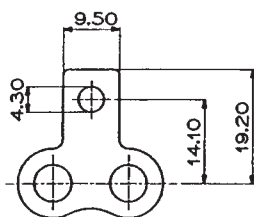

ATTACCO MAGLIA INTERNA
INNER PLATE ATTACHMENT

ATTACCO MAGLIA ESTERNA
OUTER PLATE ATTACHMENT

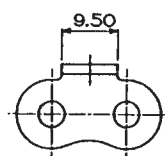
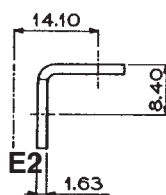
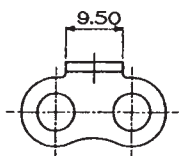

EK2

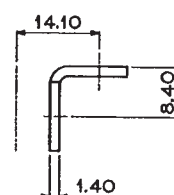

E1

EK1

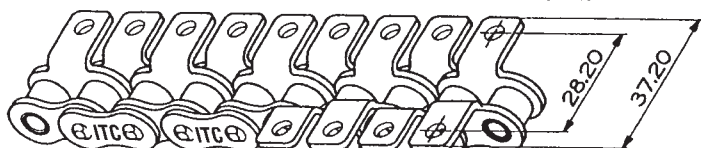
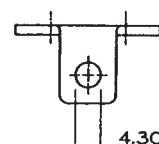
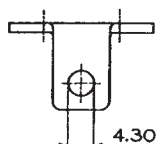

TRASPORTO LEGGERO / LIGHT TRANSPORT

**GLI ATTACCHI STANDARD
STANDARD ATTACHMENTS**

Per catena "ITC" 5/8" (ISO 10B) - Passo 15,875 mm.

For "ITC" chain 5/8" (ISO 10B) - Pitch 15,875 mm.

Nota: Tutte le dimensioni indicate, sono espresse in mm.

Note: All dimensions are expressed in mm.

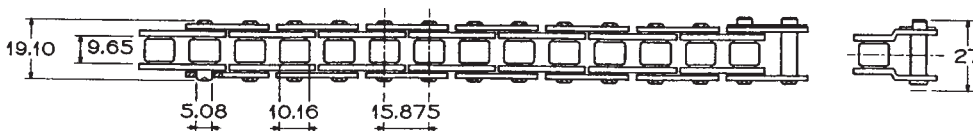

**ATTACCO MAGLIA INTERNA
INNER PLATE ATTACHMENT**

**ATTACCO MAGLIA ESTERNA
OUTER PLATE ATTACHMENT**

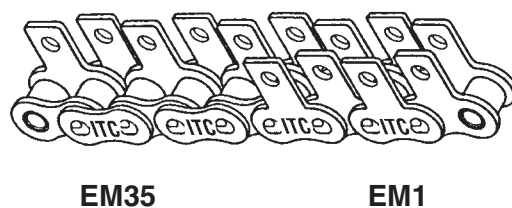
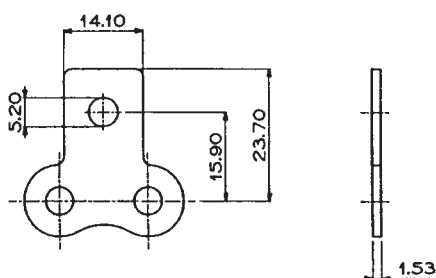
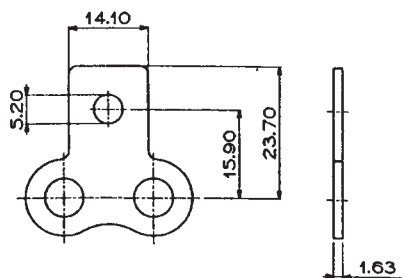

EM35

EM1

**ATTACCO MAGLIA INTERNA
INNER PLATE ATTACHMENT**

**ATTACCO MAGLIA ESTERNA
OUTER PLATE ATTACHMENT**

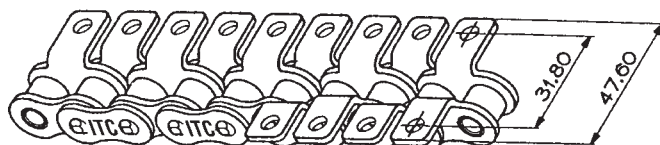
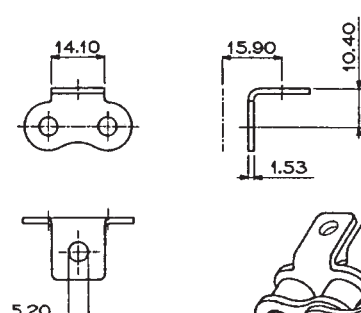
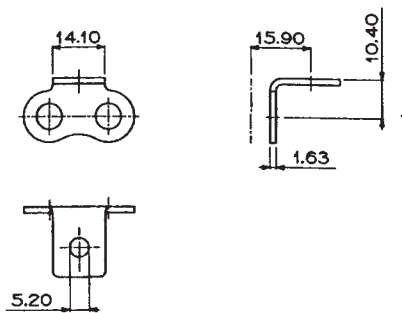

E1

EK1

TRASPORTO LEGGERO / LIGHT TRANSPORT

**GLI ATTACCHI STANDARD
STANDARD ATTACHMENTS**

Per catena "ITC" 5/8" (ISO 10B) - Passo 15,875 mm.

For "ITC" chain 5/8" (ISO 10B) - Pitch 15,875 mm.

Nota: Tutte le dimensioni indicate, sono espresse in mm.

Note: All dimensions are expressed in mm.

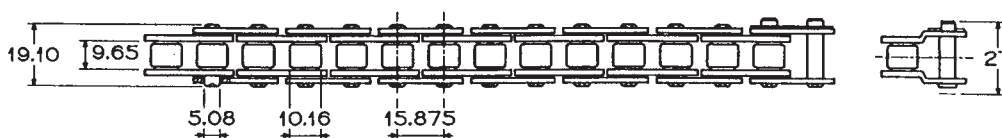

**ATTACCO MAGLIA INTERNA
INNER PLATE ATTACHMENT**

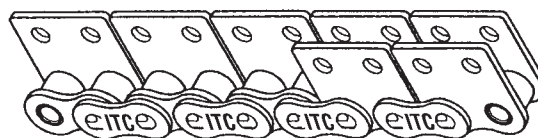
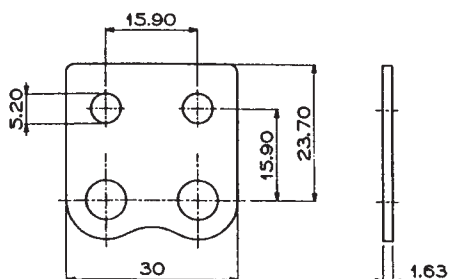

EM35-2

EM2

**ATTACCO MAGLIA ESTERNA
OUTER PLATE ATTACHMENT**

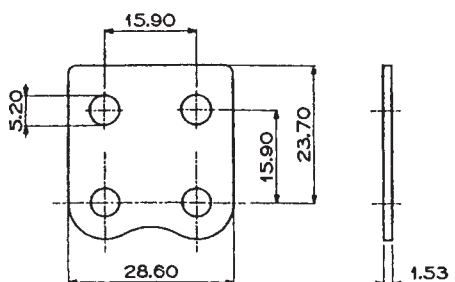

EM35-2

EM2

TRASPORTO LEGGERO / LIGHT TRANSPORT

**GLI ATTACCHI STANDARD
STANDARD ATTACHMENTS**

Per catena "ITC" 5/8" (ISO 10B) - Passo 15,875 mm.

For "ITC" chain 5/8" (ISO 10B) - Pitch 15,875 mm.

Nota: Tutte le dimensioni indicate, sono espresse in mm.

Note: All dimensions are expressed in mm.

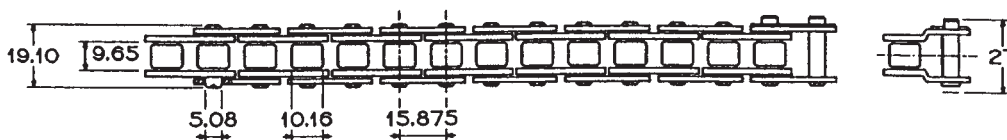

**ATTACCO MAGLIA INTERNA
INNER PLATE ATTACHMENT**

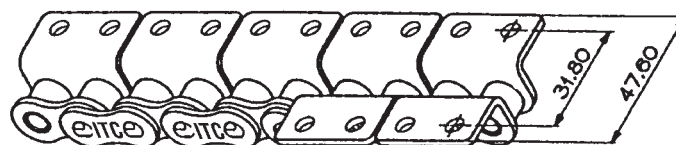
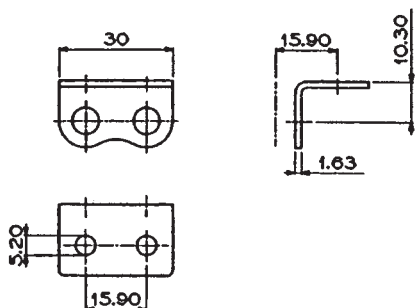

E2

EK2

**ATTACCO MAGLIA ESTERNA
OUTER PLATE ATTACHMENT**

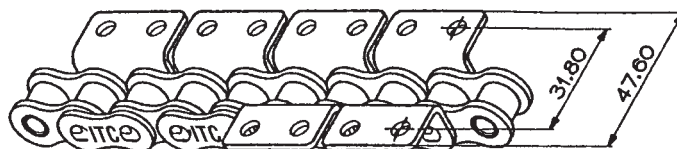
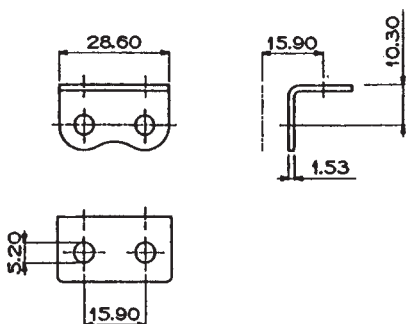

E2

EK2

TRASPORTO LEGGERO / LIGHT TRANSPORT

**GLI ATTACCHI STANDARD
STANDARD ATTACHMENTS**

Per catena "ITC" 3/4" (ISO 12B) - Passo 19,05 mm.

For "ITC" chain 3/4" (ISO 12B) - Pitch 19,05 mm.

Nota: Tutte le dimensioni indicate, sono espresse in mm.

Note: All dimensions are expressed in mm.

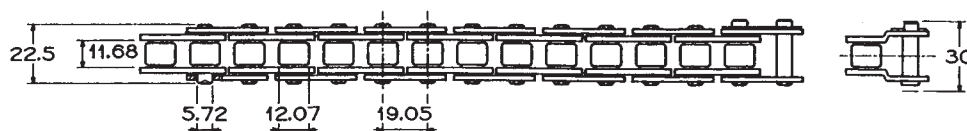

**ATTACCO MAGLIA INTERNA
INNER PLATE ATTACHMENT**

**ATTACCO MAGLIA ESTERNA
OUTER PLATE ATTACHMENT**

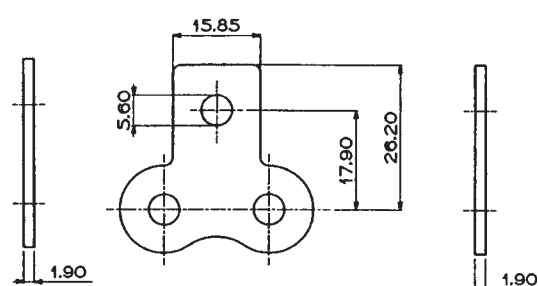
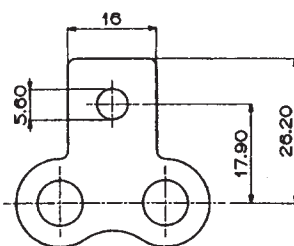

**ATTACCO MAGLIA INTERNA
INNER PLATE ATTACHMENT**

**ATTACCO MAGLIA ESTERNA
OUTER PLATE ATTACHMENT**

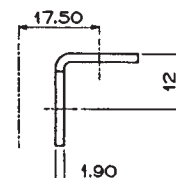
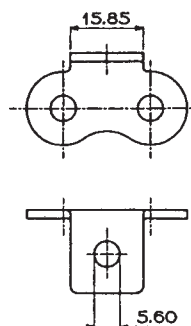
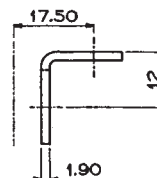
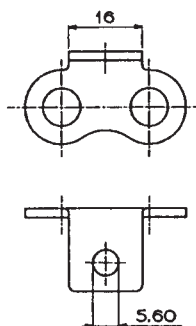
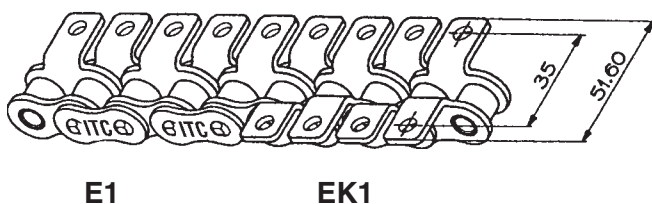

TRASPORTO LEGGERO / LIGHT TRANSPORT

**GLI ATTACCHI STANDARD
STANDARD ATTACHMENTS**

Per catena "ITC" 3/4" (ISO 12B) - Passo 19,05 mm.

For "ITC" chain 3/4" (ISO 12B) - Pitch 19,05 mm.

Nota: Tutte le dimensioni indicate, sono espresse in mm.

Note: All dimensions are expressed in mm.

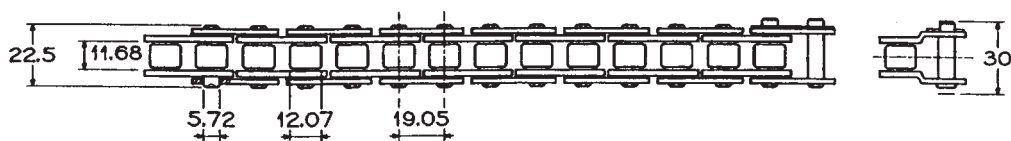

**ATTACCO MAGLIA INTERNA
INNER PLATE ATTACHMENT**

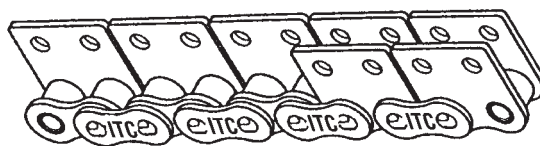
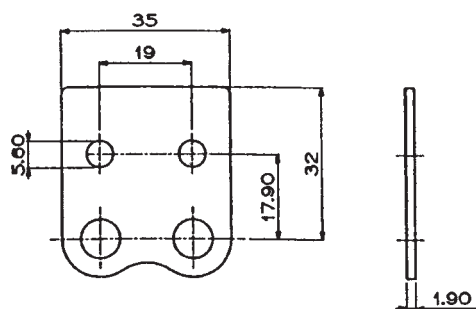

EM35-2

EM2

**ATTACCO MAGLIA ESTERNA
OUTER PLATE ATTACHMENT**

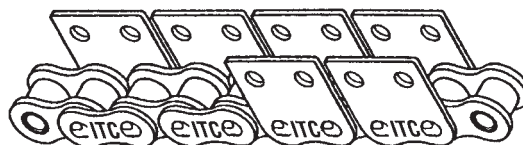
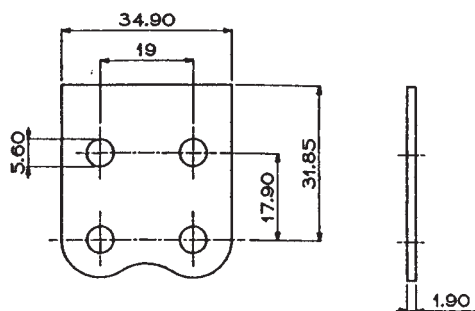

EM35-2

EM2

TRASPORTO LEGGERO / LIGHT TRANSPORT

**GLI ATTACCHI STANDARD
STANDARD ATTACHMENTS**

Per catena "ITC" 3/4" (ISO 12B) - Passo 19,05 mm.

For "ITC" chain 3/4" (ISO 12B) - Pitch 19,05 mm.

Nota: Tutte le dimensioni indicate, sono espresse in mm.

Note: All dimensions are expressed in mm.

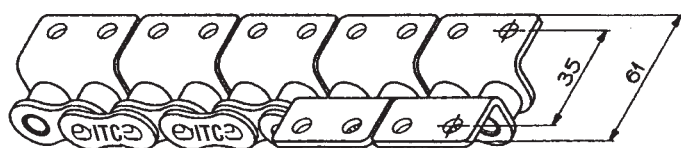
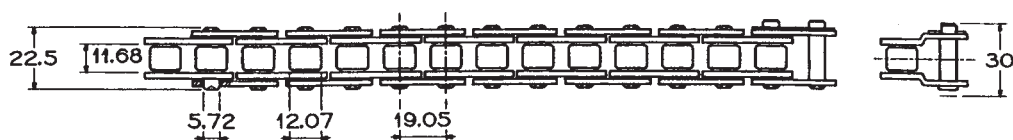

E2

EK2

**ATTACCO MAGLIA INTERNA
INNER PLATE ATTACHMENT**

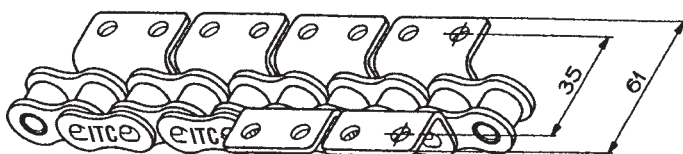
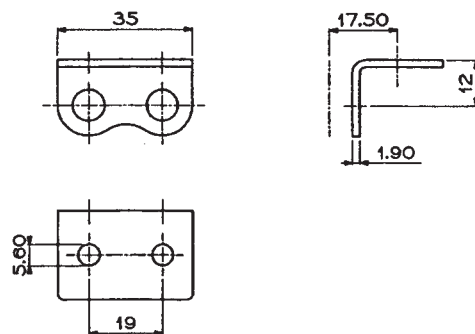

E2

EK2

**ATTACCO MAGLIA ESTERNA
OUTER PLATE ATTACHMENT**

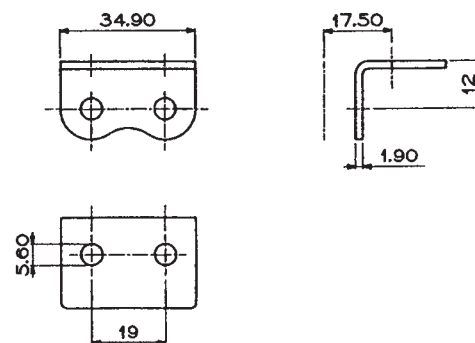

TRASPORTO LEGGERO / LIGHT TRANSPORT

**GLI ATTACCHI STANDARD
STANDARD ATTACHMENTS**

Per catena "ITC" 1" (ISO 16B) - Passo 25,4 mm.

For "ITC" chain 1" (ISO 16B) - Pitch 25,4 mm.

Nota: Tutte le dimensioni indicate, sono espresse in mm.

Note: All dimensions are expressed in mm.

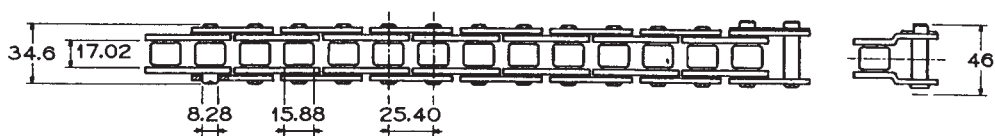

**ATTACCO MAGLIA INTERNA
INNER PLATE ATTACHMENT**

**ATTACCO MAGLIA ESTERNA
OUTER PLATE ATTACHMENT**

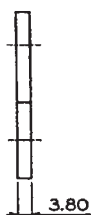
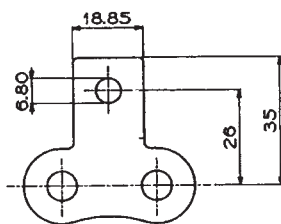
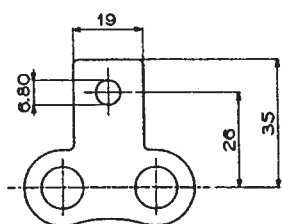

EM35

EM1

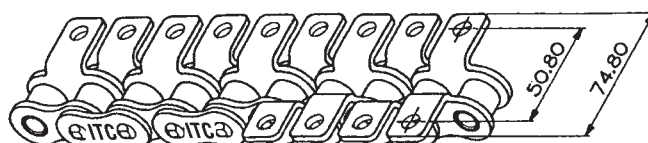
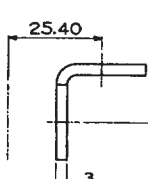
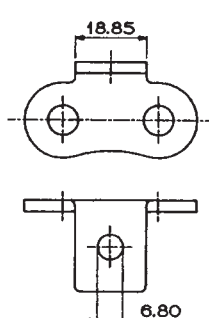
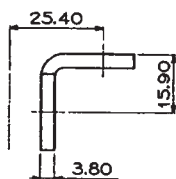
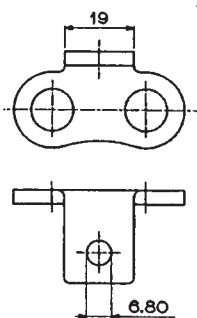

E1

EK1

TRASPORTO LEGGERO / LIGHT TRANSPORT

**GLI ATTACCHI STANDARD
STANDARD ATTACHMENTS**

Per catena "ITC" 1" (ISO 16B) - Passo 25,4 mm.

For "ITC" chain 1" (ISO 16B) - Pitch 25,4 mm.

Nota: Tutte le dimensioni indicate, sono espresse in mm.

Note: All dimensions are expressed in mm.

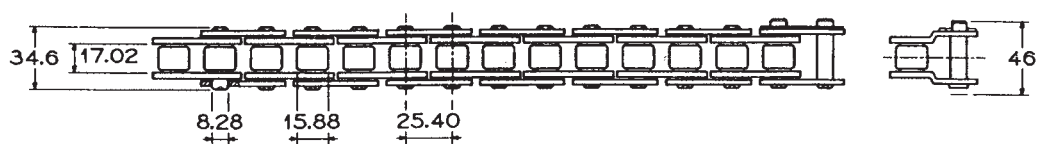

**ATTACCO MAGLIA ESTERNA
OUTER PLATE ATTACHMENT**

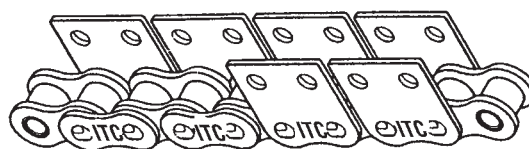
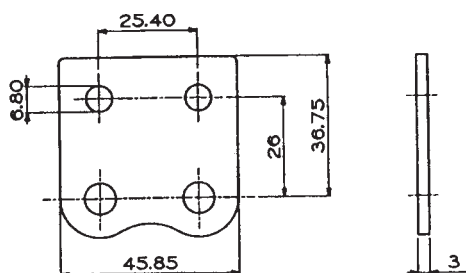

EM35

EM2

**ATTACCO MAGLIA INTERNA
INNER PLATE ATTACHMENT**

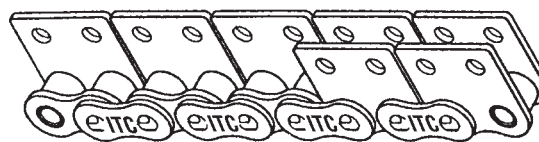
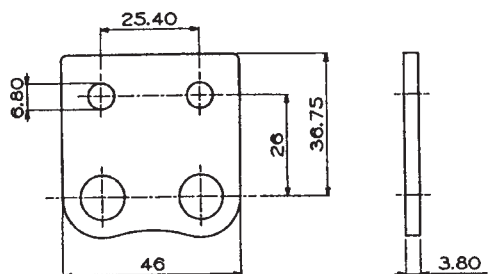

EM35-2

EM2

TRASPORTO LEGGERO / LIGHT TRANSPORT

**GLI ATTACCHI STANDARD
STANDARD ATTACHMENTS**

Per catena "ITC" 1" (ISO 16B) - Passo 25,4 mm.

For "ITC" chain 1" (ISO 16B) - Pitch 25,4 mm.

Nota: Tutte le dimensioni indicate, sono espresse in mm.

Note: All dimensions are expressed in mm.

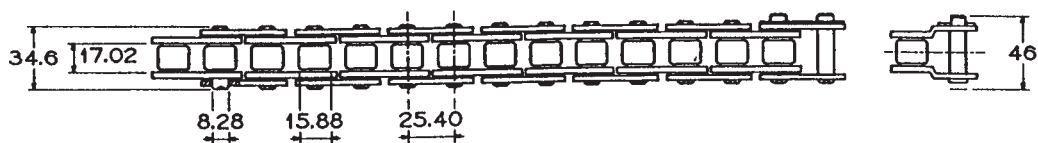

**ATTACCO MAGLIA INTERNA
INNER PLATE ATTACHMENT**

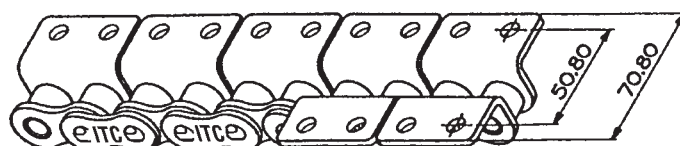
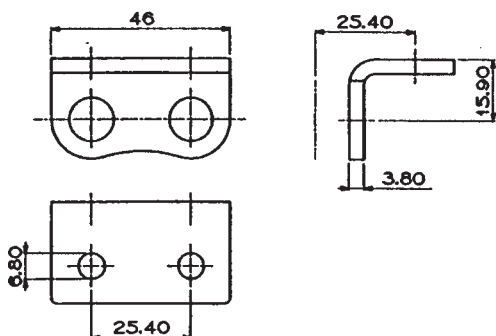

E2

EK2

**ATTACCO MAGLIA ESTERNA
OUTER PLATE ATTACHMENT**

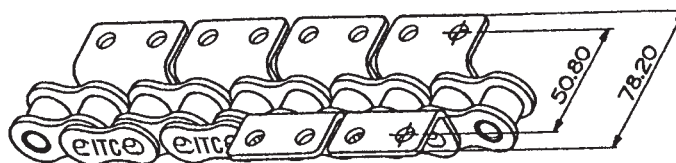
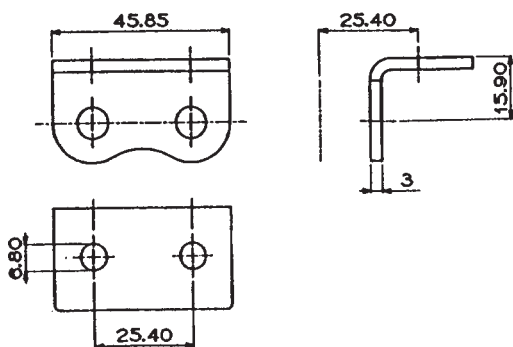

E2

EK2

TRASPORTO LEGGERO / LIGHT TRANSPORT

**GLI ATTACCHI STANDARD
STANDARD ATTACHMENTS**

Per catena "ITC" 1" 1/4 (ISO 20B) - Passo 31,75 mm.

For "ITC" chain 1" 1/4 (ISO 20B) - Pitch 31,75 mm.

Nota: Tutte le dimensioni indicate, sono espresse in mm.

Note: All dimensions are expressed in mm.

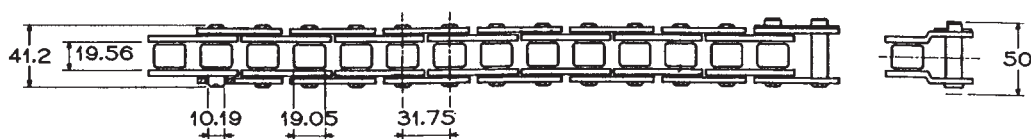

**ATTACCO MAGLIA ESTERNA
OUTER PLATE ATTACHMENT**

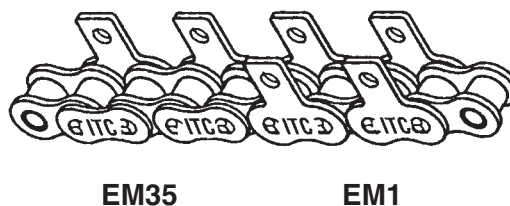
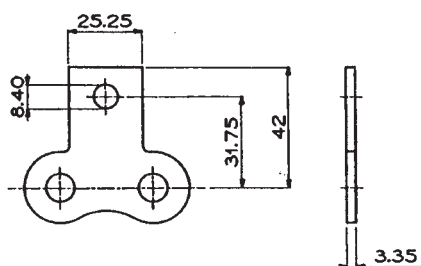

EM35

EM1

**ATTACCO MAGLIA INTERNA
INNER PLATE ATTACHMENT**

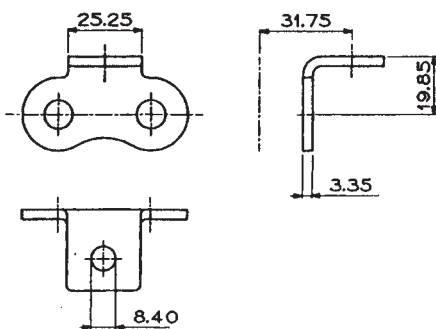

E1

EK1



TRASPORTO LEGGERO / LIGHT TRANSPORT

CATENE CON CAVALLOTTI "ITC" VULCANIZZATI CHAINS WITH "ITC" VULCANIZED BENT - ATTACHMENTS

Il concepimento di queste catene, è dettato soprattutto dalla particolarità dell'impiego nell'industria vetraria, laterizi e del legno, laddove l'esigenza di un appoggio gommato, vulcanizzato su di una catena di base, risolve ampiamente le problematiche inerenti a tali applicazioni.

These chains are suitable for any application requiring a rubbered support, vulcanized on a standard chain. These types are particularly requested in glass industry, tiles and wood factories.

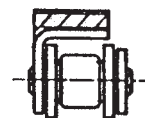

Giunto con molletta
Connecting link with spring

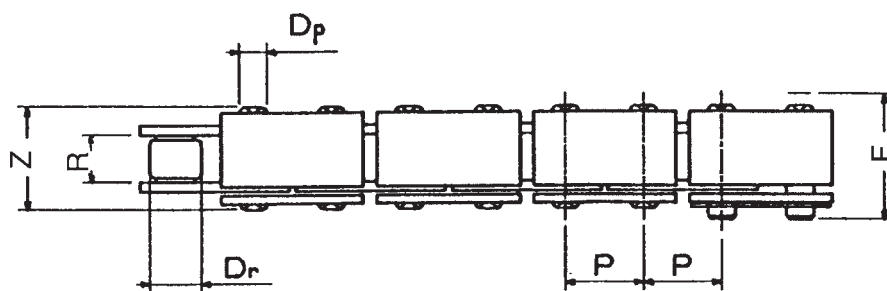

SERIE EUROPEA / EUROPEAN SERIES

Passo Pitch	Diam. rullo max. Max roller diam. Dr mm	Largh. Int. min. Width between inner plates R mm	Diam. perno max Max pin diam. Dp mm	Altezza piastra max Inner plate depth Y mm	Largh. catena ribad. max Width over connecting pins Z mm	Ingombro catena max Width over bearing pins F mm	Superf. di lavoro Working surface mm ²	Carico di rottura medio Medium breaking load N	Peso approx Approx. weight Kg/m
9,525	6,35	5,72	3,28	8,26	12,8	19	28	9.510	0,55
12,70	8,51	7,75	4,45	11,81	16,5	24	50	18.050	0,89
15,875	10,16	6,48	5,08	14,73	15,7	24	52	23.770	0,98

TRASPORTO LEGGERO / LIGHT TRANSPORT

CATENE CON CAVALLOTTI "ITC" VULCANIZZATI
CHAINS WITH "ITC" VULCANIZED BENT - ATTACHMENTS

Per talune applicazioni, e sostanzialmente per le catene a doppia fila di rulli, il cavallotto, può essere fornito, senza il piattello vulcanizzato in gomma.

For some applications, mainly concerning double strand roller chains, bent attachment can be supplied without vulcanized cup in rubber.

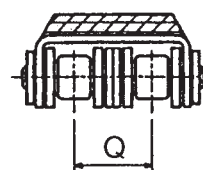

Giunto con molletta
 Connecting link with spring

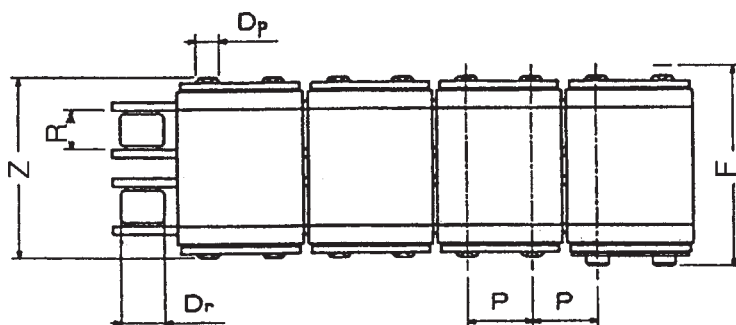

SERIE EUROPEA / EUROPEAN SERIES

Passo Pitch	Diam. rullo max. Max roller diam.	Largh. Int. min. Width between inner plates	Diam. perno max Max pin diam.	Altezza piastra max Inner plate depth	Largh. catena ribad. max Width over connecting pins	Ingombro catena max Width over bearing pins	Superf. di lavoro Working surface	Carico di rottura medio Medium breaking load	Peso approx Approx. weight
P mm	Dr mm	R mm	Dp mm	Y mm	Z mm	F mm	mm ²	N	Kg/m
12,70	8,51	7,75	4,45	11,81	13,92	34,5	100	34.050	2,05
* 12,70	8,51	7,75	4,45	11,81	13,92	34,5	100	34.050	1,95
15,875	10,16	9,65	5,08	14,73	16,59	39,0	137	47.560	2,80
* 15,875	10,16	9,65	5,08	14,73	16,59	39,0	137	47.560	2,64

* Catena con cavallotto, ma senza piattello vulcanizzato / Chain with bent attachment, without vulcanized cup

TRASPORTO LEGGERO / LIGHT TRANSPORT

**CATENE A RULLI “ITC” CON “passo lungo”
“ITC” ROLLER CHAINS WITH “LONG-PITCH”**

Catene di derivazione esecutiva dalle tipologie Europea ed Americana, dalle quali differiscono per le dimensioni del passo, che è doppio, pur mantenendo inalterate le dimensioni dei perni, bussole e rulli integrali, equivalenti alle grandezze corrispondenti.

Solitamente, trovano impiego per la loro semplicità, ed economicità, in trasmissioni aventi interassi particolarmente lunghi, e con carichi e velocità di valore relativamente contenuto.

These chains come from European and American types: pins, sleeves and integral rollers dimensions are identical, whereas the pitch changes, it's in these case double. Usually because of their very low costs and simplicity, are assembled in transmissions having very long distance between centers, low speeds and light loads.

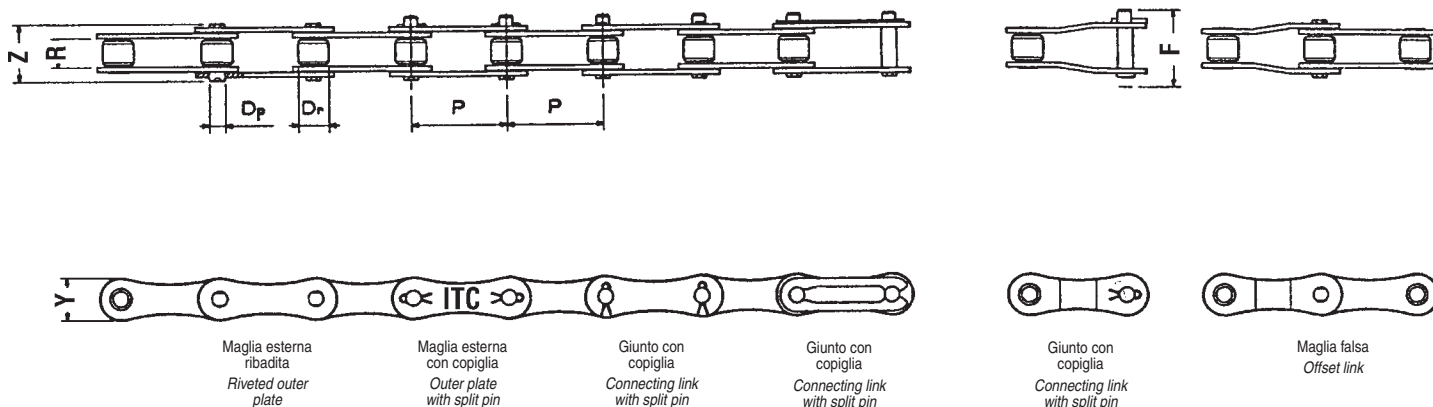

SERIE EUROPEA / EUROPEAN SERIES

ITC N°	ISO N°	Passo	Diam. rullo	Largh. Int.	Diam. perno	Altezza piastra	Largh. catena	Ingombro catena	Superf. di lavoro	Carico di rottura medio	Peso approx.
		Pitch	Max roller diam.	Width between inner plates	Max pin diam.	Inner plate depth	Width over connecting pins	Width over bearing pins			
		P mm	Dr mm	R mm	Dp mm	Y mm	Z mm	F mm	mm ²	N	Kg/m
C2126	208B	25,40	8,51	7,75	4,45	11,81	16,5	24	50	18.050	0,52
C2136	210B	31,75	10,16	9,65	5,08	14,73	19,1	27	69	23.750	0,58

SERIE AMERICANA / AMERICAN SERIES

ITC N°	ISO N°	Passo	Diam. rullo	Largh. Int.	Diam. perno	Altezza piastra	Largh. catena	Ingombro catena	Superf. di lavoro	Carico di rottura medio	Peso approx.
		Pitch	Max roller diam.	Width between inner plates	Max pin diam.	Inner plate depth	Width over connecting pins	Width over bearing pins			
		P mm	Dr mm	R mm	Dp mm	Y mm	Z mm	F mm	mm ²	N	Kg/m
C2050	210A	31,75	10,16	9,40	5,09	15,09	20,5	28	70	25.220	0,65
C2060H	-	38,10	11,91	12,57	5,96	18,08	29,6	36	115	36.100	1,26

TRASPORTO LEGGERO / LIGHT TRANSPORT

CATENE PER TRASPORTO A "PASSO LUNGO" "LONG-PITCH" TRANSPORT CHAINS

Normalmente vengono definite catene a "passo allungato", e vengono abitualmente utilizzate soprattutto nei trasportatori leggeri.

Usually known as "extended pitch" chains, these are habitually assembled in light transports.

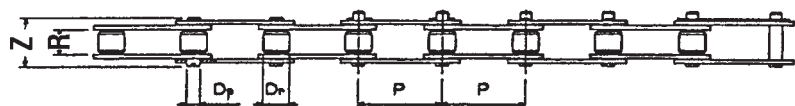

"CON RULLI STANDARD"
"WITH STANDARD ROLLERS"



Maglia esterna ribadita
Riveted outer plate

Maglia esterna con copiglie
Outer plate with split pins

Giunto con copiglie
Connecting link with split pins

Giunto con molletta
Connecting link with spring



Maglia falsa con copiglia
Offset link with split pin



Maglia falsa (3 rulli)
Three rollers offset link

SERIE AMERICANA / AMERICAN SERIES

ITC N°	ISO N°	Passo Pitch	Diam. rullo max. Max roller diam.	Largh. Int. min. Width between inner plates	Diam. perno max Max pin diam.	Altezza piastra max Inner plate depth	Largh. catena ribad. max Width over connecting pins	Ingombro catena max Width over bearing pins	Superf. di lavoro Working surface	Carico di rottura medio Medium breaking load	Peso approx. weight
		P mm	Dr mm	R mm	Dp mm	Y mm	Z mm	F mm	mm ²	N	Kg/m
C2040	C208AS	25,40	7,95	7,85	3,98	12,07	16,05	23	44	16.650	0,50
C2050	C210AS	31,75	9,40	9,40	5,09	15,09	20,5	28	70	25.200	0,85
* C2050H	–	31,75	9,40	9,40	5,09	15,09	23,0	30	74	25.200	0,90
C2060H	–	38,10	12,57	12,57	5,96	18,08	29,6	36	115	36.150	1,49
C2080H	–	50,80	15,75	15,75	7,94	24,13	36,6	43	190	62.800	2,38
C2100H	–	63,50	18,90	18,90	9,54	30,18	43,7	52	275	103.700	3,71
C2120H	–	76,20	25,22	25,22	11,11	36,20	53,8	64	410	146.500	5,35

* Eseguita con piastre rinforzate ed 1 foro centrale di diametro 7 mm. su tutte le piastre
With reinforced plates and 1 central hole of 7 mm diam. on every plates

TRASPORTO LEGGERO / LIGHT TRANSPORT

**GLI ATTACCHI STANDARD
STANDARD ATTACHMENTS**

Per catena "ITC" E2126 - Passo 25,4 mm.

For "ITC" chain E2126 - Pitch 25,4 mm.

Nota: Tutte le dimensioni indicate, sono espresse in mm.

Note: All dimensions are expressed in mm.

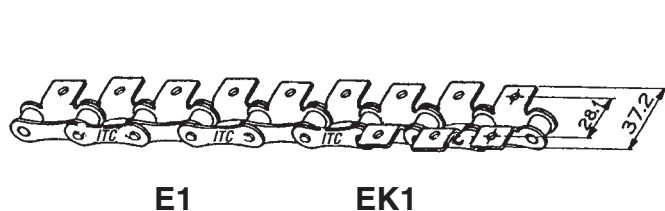
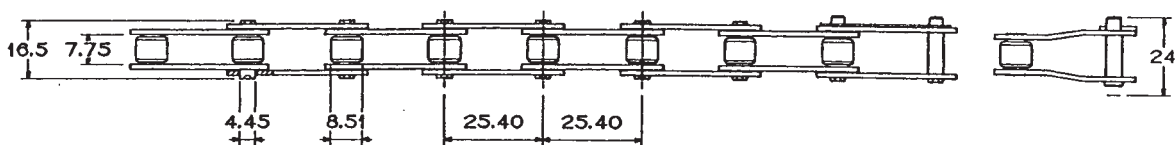

E1

EK1

**ATTACCO MAGLIA ESTERNA
OUTER PLATE ATTACHMENT**

**ATTACCO MAGLIA INTERNA
INNER PLATE ATTACHMENT**

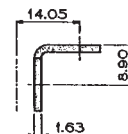
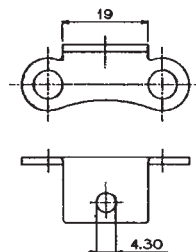
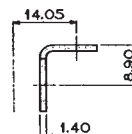
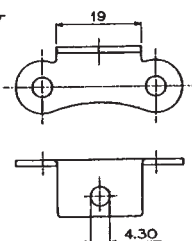

EM35

EM1

**ATTACCO MAGLIA ESTERNA
OUTER PLATE ATTACHMENT**

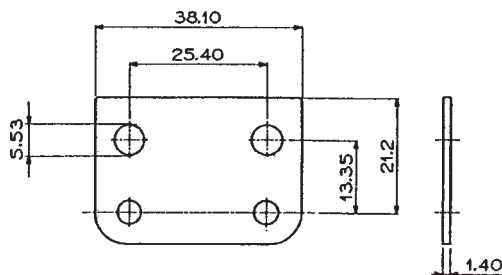

TRASPORTO LEGGERO / LIGHT TRANSPORT

**GLI ATTACCHI STANDARD
STANDARD ATTACHMENTS**

Per catena "ITC" E2136 - Passo 31,75 mm.

For "ITC" chains E2136 - Pitch 25,4 mm.

Nota: Tutte le dimensioni indicate, sono espresse in mm.

Note: All dimensions are expressed in mm.

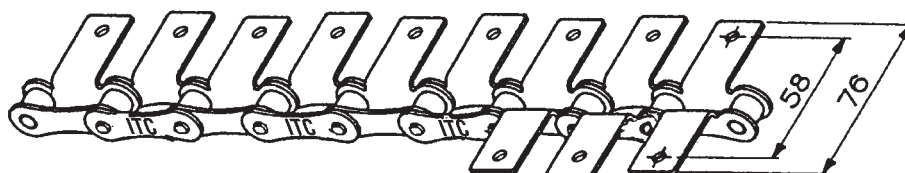
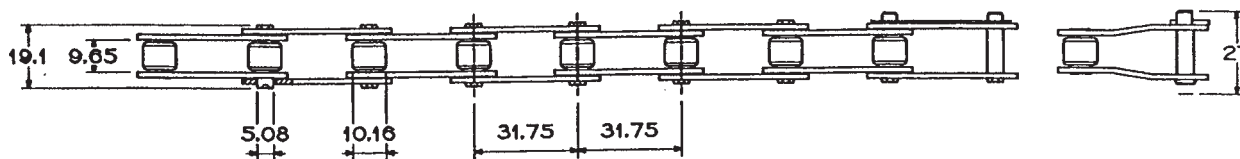

E1

EK1

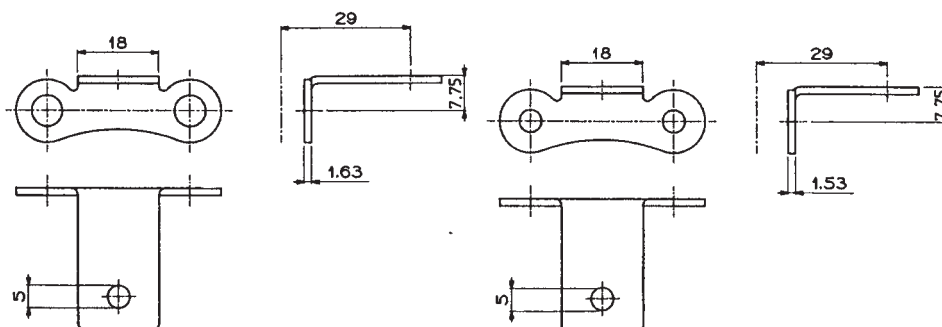

TRASPORTO LEGGERO / LIGHT TRANSPORT

CATENE PER TRASPORTO A "PASSO LUNGO" "LONG-PITCH" TRANSPORT CHAINS

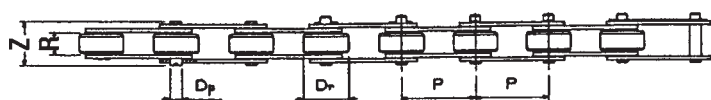

"CON RULLI PORTANTI"
"WITH SUPPORTING ROLLERS"



Maglia esterna
ribadita
Riveted outer
plate

Maglia esterna
con copiglie
Outer plate
with split pins

Giunto con
copiglia
Connecting link
with link split



Maglia falsa
con copiglia
Offset link
with split pin



Maglia falsa
Offset link

SERIE AMERICANA / AMERICAN SERIES

ITC N°	ISO N°	Passo Pitch	Diam. rullo max. Max roller diam.	Largh. Int. min. Width between inner plates	Diam. perno max Max pin diam.	Altezza piastra max Inner plate depth	Largh. catena ribad. max Width over connecting pins	Ingombro catena max Width over bearing pins	Superf. di lavoro Working surface	Carico di rottura medio Medium breaking load	Peso approx Approx. weight
		P mm	Dr mm	R mm	Dp mm	Y mm	Z mm	F mm	mm ²	N	Kg/m
C2042	C208AL	25,40	15,88	7,85	3,98	12,07	16,05	23	44	16.650	0,86
C2052	C210AL	31,75	19,05	9,40	5,09	15,09	20,5	28	70	25.200	1,34
* C2052H	–	31,75	19,05	9,40	5,09	15,09	23,0	30	74	25.200	1,39
C2062H	–	38,10	22,23	12,57	5,96	18,08	29,6	36	115	36.150	2,20
C2082H	–	50,80	28,58	15,75	7,94	24,13	36,6	43	190	62.800	3,42
C2102H	–	63,50	39,67	18,90	9,54	30,18	43,7	52	275	103.700	5,94
C2122H	–	76,20	44,45	25,22	11,11	36,20	53,8	64	410	146.500	8,47

* Eseguita con piastre rinforzate ed 1 foro centrale di diametro 7 mm. su tutte le piastre
With reinforced plates and 1 central hole of 7 mm diam. on every plates

TRASPORTO LEGGERO / LIGHT TRANSPORT

ATTACCHI "ED1" PER CATENE A RULLI A "PASSO LUNGO"

"ED1" ATTACHMENTS FOR "LONG-PITCH" ROLLER CHAINS

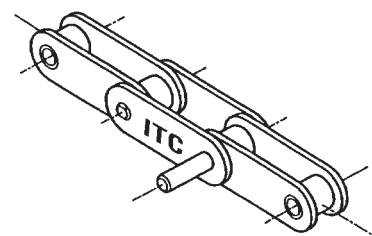
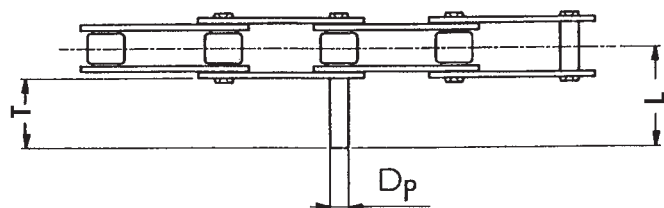

ITC N°	Passo Pitch	Diam. perno max Max pin diam.	T mm	L mm
	P mm	Dp mm		
C2040	25,40	3,98	9,5	16,7
C2042	25,40	3,98	9,5	16,7
C2050	31,75	5,09	11,9	21,0
C2052	31,75	5,09	11,9	21,0
C2050H	31,75	5,09	11,9	21,8
C2052H	31,75	5,09	11,9	21,8
C2060H	38,10	5,96	14,6	27,8
C2062H	38,10	5,96	14,6	27,8
C2080H	50,80	7,94	19,0	35,3
C2082H	50,80	7,94	19,0	35,3
C2100H	63,50	9,54	23,8	43,4
C2102H	63,50	9,54	23,8	43,4
C2020H	76,20	11,11	28,6	52,4
C2122H	76,20	11,11	28,6	52,4

Il perno "ED1", può essere fornito, a richiesta, per esigenze particolari, con dimensioni e lunghezze variabili.

"ED1" pin can be supplied, under request, with different dimensions and lengths.

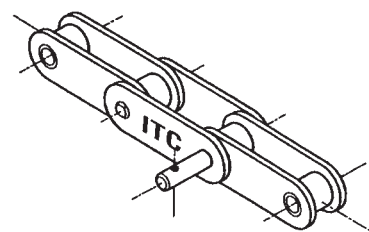

Il perno "ED1", può essere fornito, a richiesta, completo di foro per copiglia, posto nella sua parte sporgente.

"ED1" pin can be supplied, under request, with a hole for split pin inserted in its extending part.

TRASPORTO LEGGERO / LIGHT TRANSPORT

**GLI ATTACCHI STANDARD PER CATENE A "PASSO LUNGO"
STANDARD ATTACHMENTS FOR "LONG-PITCH" CHAINS**

Per catena "ITC" C2040 - Passo 25,4 mm.

For "ITC" chains C2040 - Pitch 25,4 mm.

Nota: Tutte le dimensioni indicate, sono espresse in mm.

Note: All dimensions are expressed in mm.

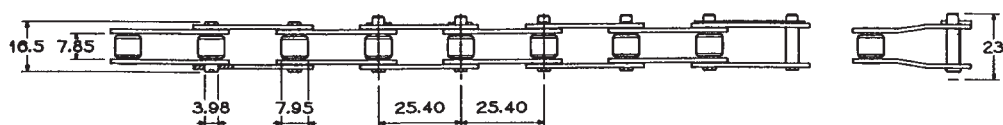

**ATTACCO MAGLIA INTERNA
INNER PLATE ATTACHMENT**

**ATTACCO MAGLIA ESTERNA
OUTER PLATE ATTACHMENT**

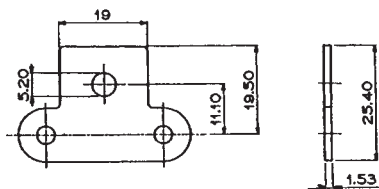
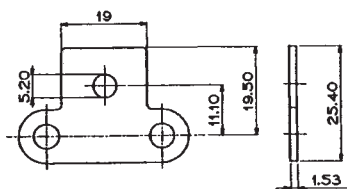

EM35

EM1

**ATTACCO MAGLIA INTERNA
INNER PLATE ATTACHMENT**

**ATTACCO MAGLIA ESTERNA
OUTER PLATE ATTACHMENT**

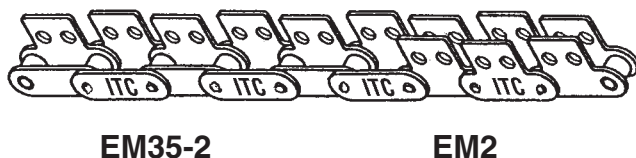
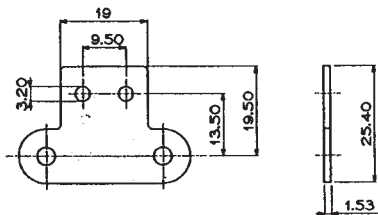
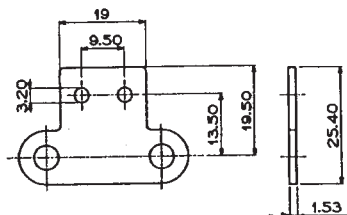

EM35-2

EM2

TRASPORTO LEGGERO / LIGHT TRANSPORT

**GLI ATTACCHI STANDARD PER CATENE A "PASSO LUNGO"
STANDARD ATTACHMENTS FOR "LONG-PITCH" CHAINS**

Per catena "ITC" C2040 - Passo 25,4 mm.

For "ITC" chain C2040 - Pitch 25,4 mm.

Nota: Tutte le dimensioni indicate, sono espresse in mm.

Note: All dimensions are expressed in mm.

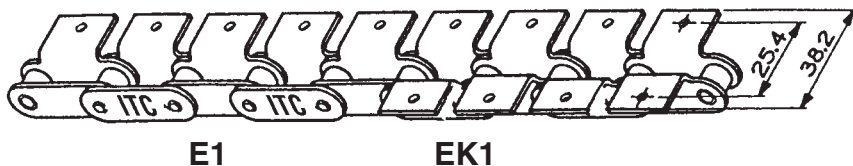

E1

EK1

ATTACCO MAGLIA INTERNA
INNER PLATE ATTACHMENT

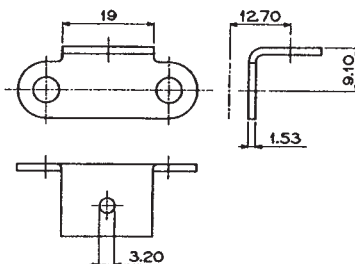

ATTACCO MAGLIA ESTERNA
OUTER PLATE ATTACHMENT

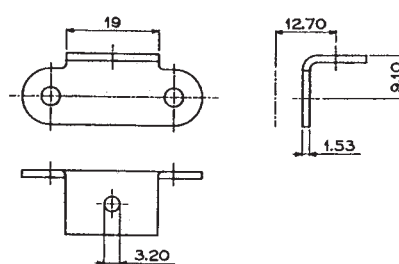

E2

EK2

ATTACCO MAGLIA INTERNA
INNER PLATE ATTACHMENT

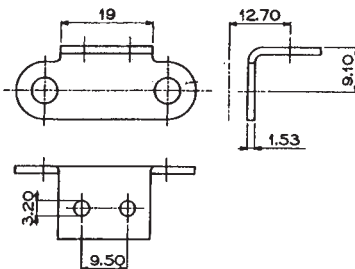

ATTACCO MAGLIA ESTERNA
OUTER PLATE ATTACHMENT

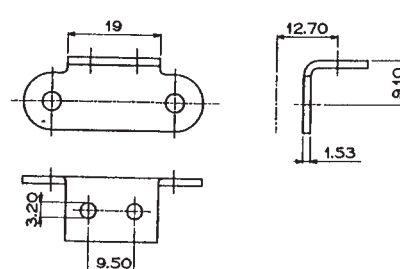

TRASPORTO LEGGERO / LIGHT TRANSPORT

**GLI ATTACCHI STANDARD PER CATENE A "PASSO LUNGO"
STANDARD ATTACHMENTS FOR "LONG-PITCH" CHAINS**

Per catena "ITC" C2050 - Passo 31,75 mm.

For "ITC" chain C2050 - Pitch 31,75 mm.

Nota: Tutte le dimensioni indicate, sono espresse in mm.

Note: All dimensions are expressed in mm.

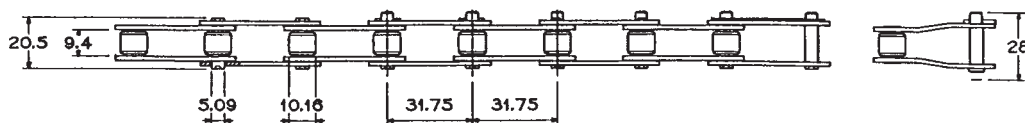

**ATTACCO MAGLIA INTERNA
INNER PLATE ATTACHMENT**

**ATTACCO MAGLIA ESTERNA
OUTER PLATE ATTACHMENT**

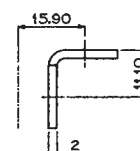
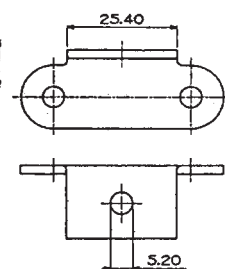
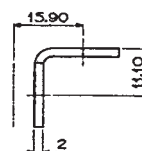
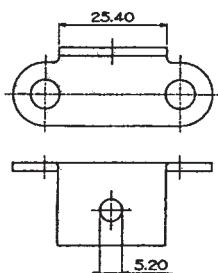
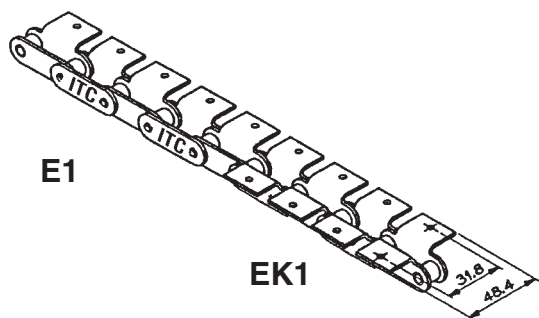

**ATTACCO MAGLIA INTERNA
INNER PLATE ATTACHMENT**

**ATTACCO MAGLIA ESTERNA
OUTER PLATE ATTACHMENT**

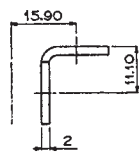
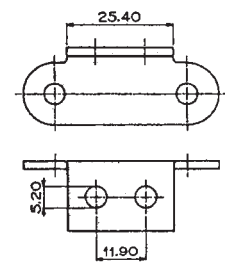
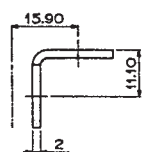
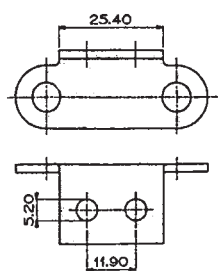
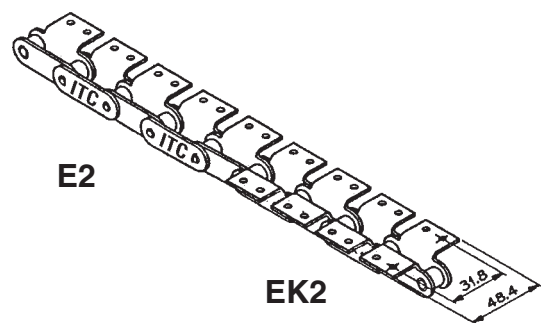

TRASPORTO LEGGERO / LIGHT TRANSPORT

**GLI ATTACCHI STANDARD PER CATENE A "PASSO LUNGO"
STANDARD ATTACHMENTS FOR "LONG-PITCH" CHAINS**

Per catena "ITC" C2050 - Passo 31,75 mm.

For "ITC" chain C2050 - Pitch 31,75 mm.

Nota: Tutte le dimensioni indicate, sono espresse in mm.

Note: All dimensions are expressed in mm.

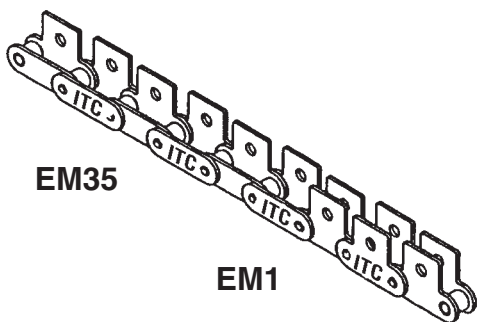
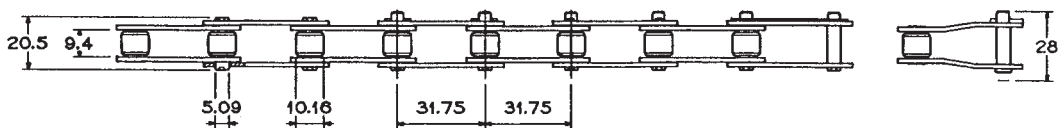

**ATTACCO MAGLIA INTERNA
INNER PLATE ATTACHMENT**

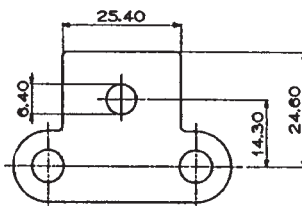

**ATTACCO MAGLIA ESTERNA
OUTER PLATE ATTACHMENT**

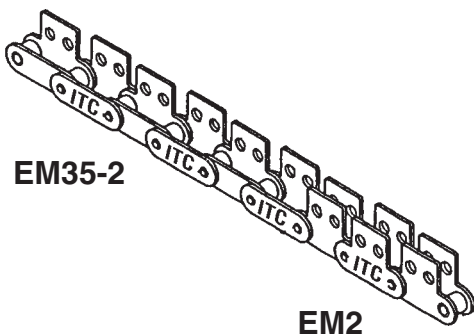
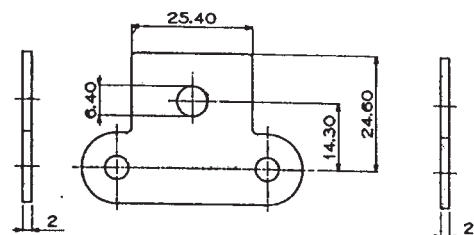

**ATTACCO MAGLIA INTERNA
INNER PLATE ATTACHMENT**

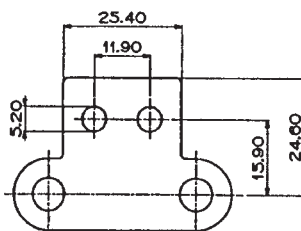

**ATTACCO MAGLIA ESTERNA
OUTER PLATE ATTACHMENT**

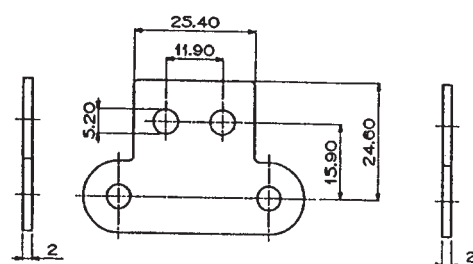

TRASPORTO LEGGERO / LIGHT TRANSPORT

**GLI ATTACCHI STANDARD PER CATENE A "PASSO LUNGO"
STANDARD ATTACHMENTS FOR "LONG-PITCH" CHAINS**

Per catena "ITC" C2060H - Passo 38,10 mm.

For "ITC" chain C2060H - Pitch 38,10 mm.

Nota: Tutte le dimensioni indicate, sono espresse in mm.

Note: All dimensions are expressed in mm.

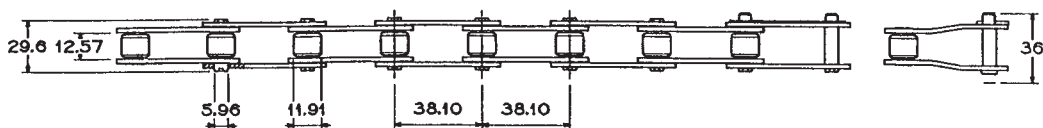

**ATTACCO MAGLIA INTERNA
INNER PLATE ATTACHMENT**

**ATTACCO MAGLIA ESTERNA
OUTER PLATE ATTACHMENT**

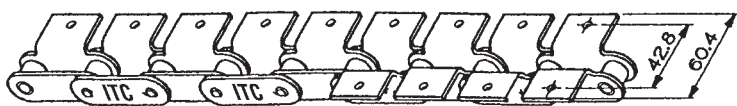
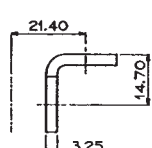
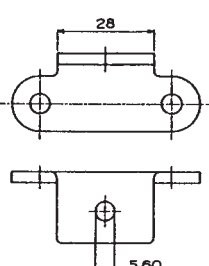
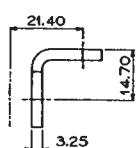
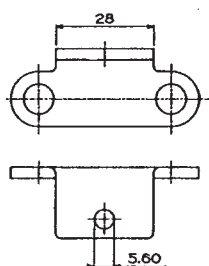

E1

EK1

**ATTACCO MAGLIA INTERNA
INNER PLATE ATTACHMENT**

**ATTACCO MAGLIA ESTERNA
OUTER PLATE ATTACHMENT**

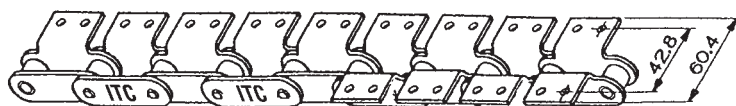
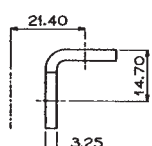
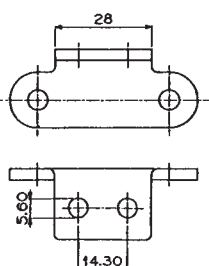
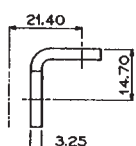
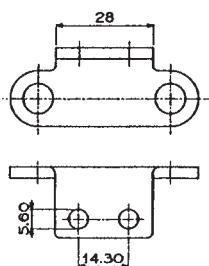

E2

EK2

TRASPORTO LEGGERO / LIGHT TRANSPORT

**GLI ATTACCHI STANDARD PER CATENE A "PASSO LUNGO"
STANDARD ATTACHMENTS FOR "LONG-PITCH" CHAINS**

Per catena "ITC" C2060H - Passo 38,10 mm.

For "ITC" chain C2060H - Pitch 38,10 mm.

Nota: Tutte le dimensioni indicate, sono espresse in mm.

Note: All dimensions are expressed in mm.

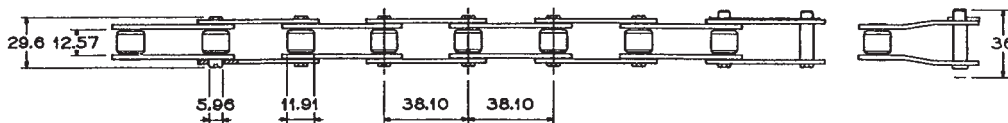

**ATTACCO MAGLIA INTERNA
INNER PLATE ATTACHMENT**

**ATTACCO MAGLIA ESTERNA
OUTER PLATE ATTACHMENT**



EM35

EM1

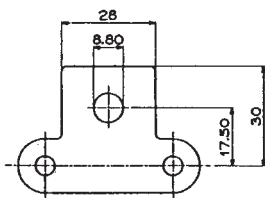
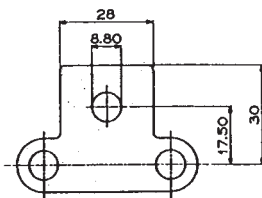

**ATTACCO MAGLIA INTERNA
INNER PLATE ATTACHMENT**

**ATTACCO MAGLIA ESTERNA
OUTER PLATE ATTACHMENT**



EM35-2

EM2

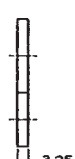
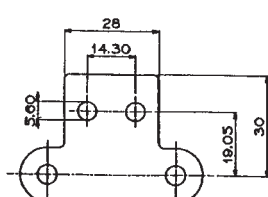
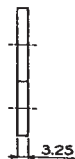
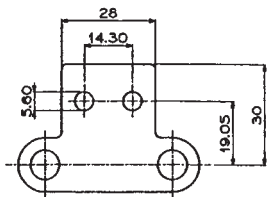

TRASPORTO LEGGERO / LIGHT TRANSPORT

**GLI ATTACCHI STANDARD PER CATENE A "PASSO LUNGO"
STANDARD ATTACHMENTS FOR "LONG-PITCH" CHAINS**

Per catena "ITC" C2080H - Passo 50,80 mm.

For "ITC" chain C2080H - Pitch 50,80 mm.

Nota: Tutte le dimensioni indicate, sono espresse in mm.

Note: All dimensions are expressed in mm.

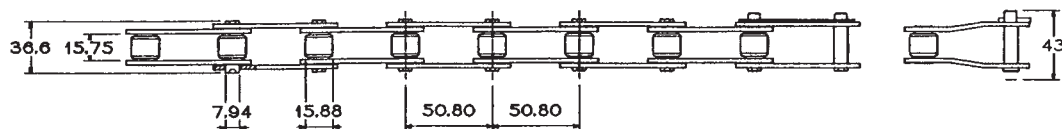

**ATTACCO MAGLIA INTERNA
INNER PLATE ATTACHMENT**

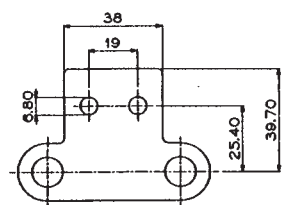

**ATTACCO MAGLIA ESTERNA
OUTER PLATE ATTACHMENT**

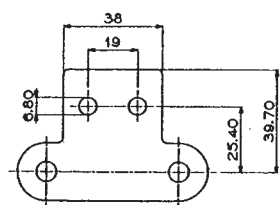

EM35-2

EM2

**ATTACCO MAGLIA INTERNA
INNER PLATE ATTACHMENT**

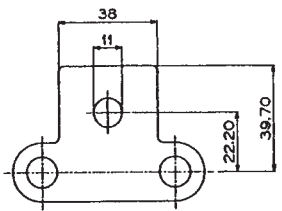

**ATTACCO MAGLIA ESTERNA
OUTER PLATE ATTACHMENT**

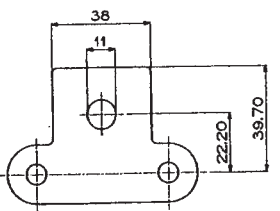

EM35

EM1

TRASPORTO LEGGERO / LIGHT TRANSPORT

**GLI ATTACCHI STANDARD PER CATENE A "PASSO LUNGO"
STANDARD ATTACHMENTS FOR "LONG-PITCH" CHAINS**

Per catena "ITC" C2080H - Passo 50,80 mm.

For "ITC" chain C2080 - Pitch 50,80 mm.

Nota: Tutte le dimensioni indicate, sono espresse in mm.

Note: All dimensions are expressed in mm.

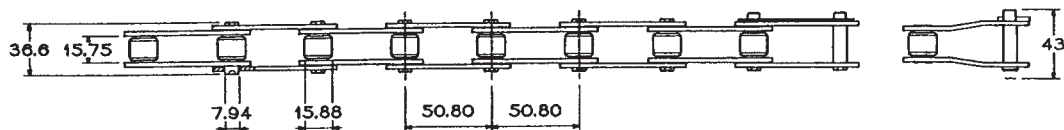

**ATTACCO MAGLIA INTERNA
INNER PLATE ATTACHMENT**

**ATTACCO MAGLIA ESTERNA
OUTER PLATE ATTACHMENT**

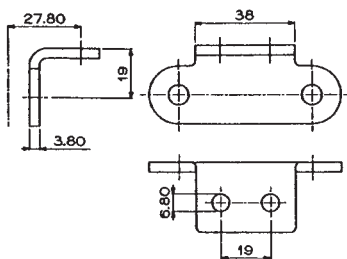
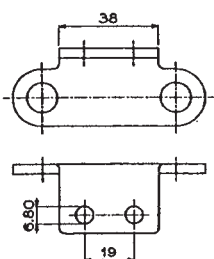

E2

EK2

**ATTACCO MAGLIA INTERNA
INNER PLATE ATTACHMENT**

**ATTACCO MAGLIA ESTERNA
OUTER PLATE ATTACHMENT**

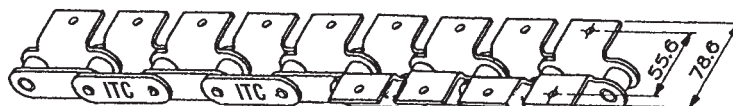
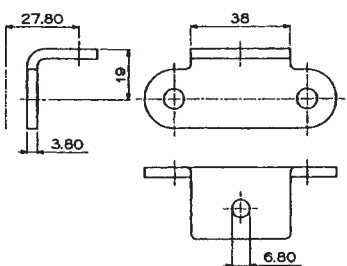
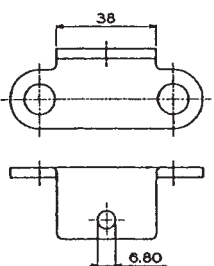

E1

EK1

TRASPORTO LEGGERO / LIGHT TRANSPORT

**GLI ATTACCHI STANDARD PER CATENE A "PASSO LUNGO"
STANDARD ATTACHMENTS FOR "LONG-PITCH" CHAINS**

Per catena "ITC" C2100H - Passo 63,50 mm.

For "ITC" chain C2100H - Pitch 63,50 mm.

Nota: Tutte le dimensioni indicate, sono espresse in mm.

Note: All dimensions are expressed in mm.

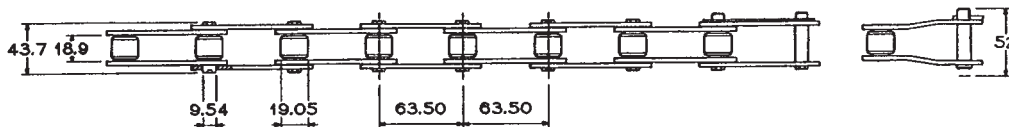

**ATTACCO MAGLIA INTERNA
INNER PLATE ATTACHMENT**

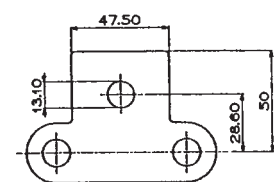

**ATTACCO MAGLIA ESTERNA
OUTER PLATE ATTACHMENT**

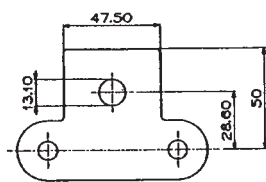

EM35

EM1

**ATTACCO MAGLIA INTERNA
INNER PLATE ATTACHMENT**

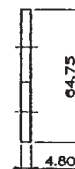
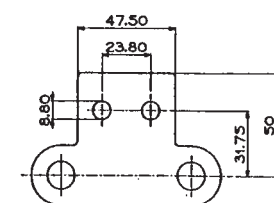

**ATTACCO MAGLIA ESTERNA
OUTER PLATE ATTACHMENT**

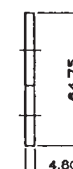
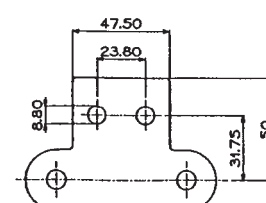

EM35-2

EM2

TRASPORTO LEGGERO / LIGHT TRANSPORT

**GLI ATTACCHI STANDARD PER CATENE A "PASSO LUNGO"
STANDARD ATTACHMENTS FOR "LONG-PITCH" CHAINS**

Per catena "ITC" C2100H - Passo 63,50 mm.

For "ITC" chain C2100H - Pitch 63,50 mm.

Nota: Tutte le dimensioni indicate, sono espresse in mm.

Note: All dimensions are expressed in mm.

**ATTACCO MAGLIA INTERNA
INNER PLATE ATTACHMENT**

**ATTACCO MAGLIA ESTERNA
OUTER PLATE ATTACHMENT**

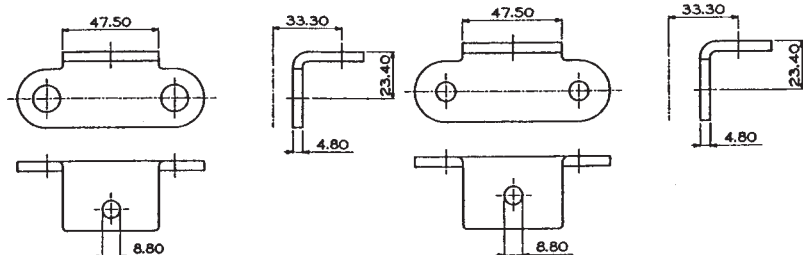

E1

EK1

**ATTACCO MAGLIA INTERNA
INNER PLATE ATTACHMENT**

**ATTACCO MAGLIA ESTERNA
OUTER PLATE ATTACHMENT**

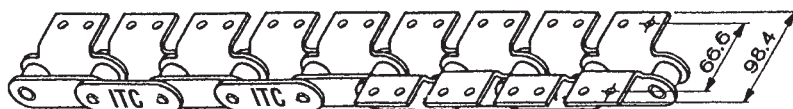
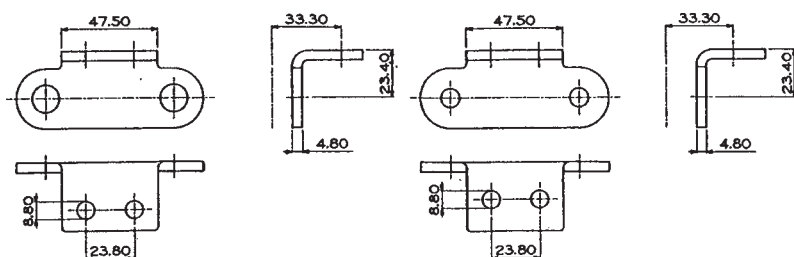

E2

EK2

TRASPORTO LEGGERO / LIGHT TRANSPORT

**GLI ATTACCHI STANDARD PER CATENE A "PASSO LUNGO"
STANDARD ATTACHMENTS FOR "LONG-PITCH" CHAINS**

Per catena "ITC" C2120H - Passo 76,20 mm.

For "ITC" chain C2120H - Pitch 76,20 mm.

Nota: Tutte le dimensioni indicate, sono espresse in mm.

Note: All dimensions are expressed in mm.

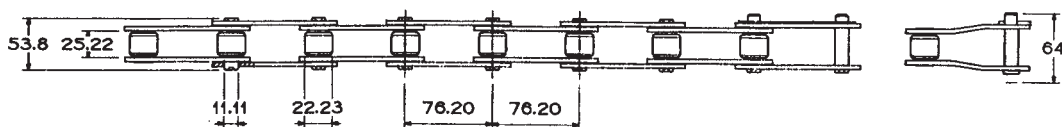

**ATTACCO MAGLIA INTERNA
INNER PLATE ATTACHMENT**

**ATTACCO MAGLIA ESTERNA
OUTER PLATE ATTACHMENT**

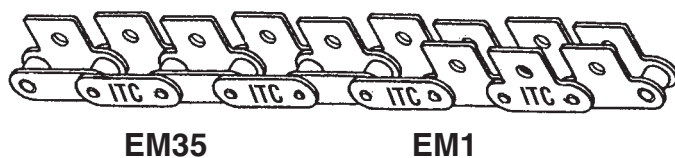
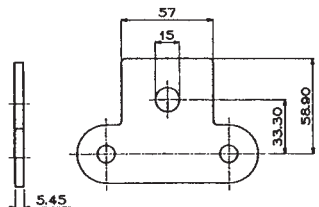
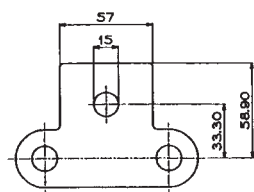

EM35

EM1

**ATTACCO MAGLIA INTERNA
INNER PLATE ATTACHMENT**

**ATTACCO MAGLIA ESTERNA
OUTER PLATE ATTACHMENT**

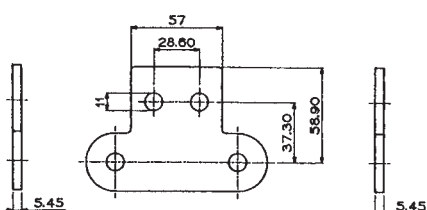
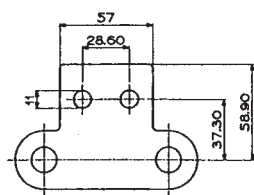

EM35-2

EM2

TRASPORTO LEGGERO / LIGHT TRANSPORT

**GLI ATTACCHI STANDARD PER CATENE A "PASSO LUNGO"
STANDARD ATTACHMENTS FOR "LONG-PITCH" CHAINS**

Per catena "ITC" C2120H - Passo 76,20 mm.

For "ITC" chain C2120H - Pitch 76,20 mm.

Nota: Tutte le dimensioni indicate, sono espresse in mm.

Note: All dimensions are expressed in mm.

**ATTACCO MAGLIA INTERNA
INNER PLATE ATTACHMENT**

**ATTACCO MAGLIA ESTERNA
OUTER PLATE ATTACHMENT**

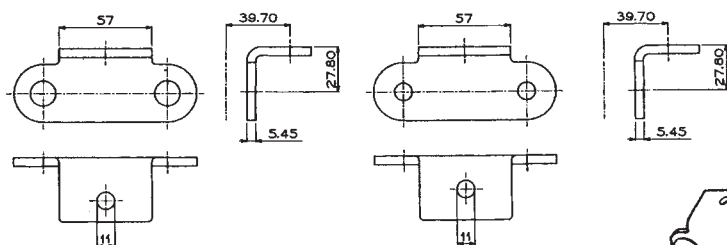

E1

EK1

**ATTACCO MAGLIA INTERNA
INNER PLATE ATTACHMENT**

**ATTACCO MAGLIA ESTERNA
OUTER PLATE ATTACHMENT**

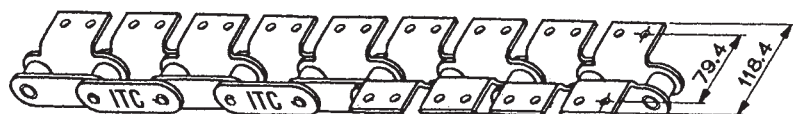
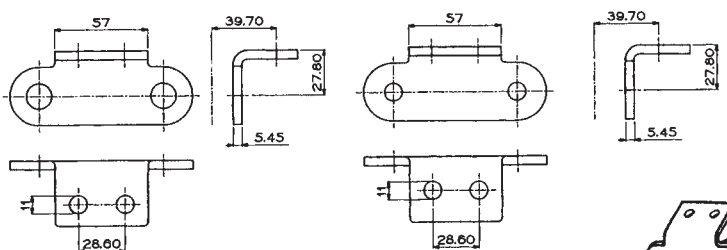

E2

EK2



TRASPORTO LEGGERO / LIGHT TRANSPORT

CATENE A RULLI A “PERNI FORATI” ROLLER CHAIN WITH HOLLOW PINS

Catene costruite col preciso intento d'aiutare l'utilizzatore, nell'adozione di attacchi personalizzati, comodamente adattabili, a queste catene, secondo le normative unificate.

Especially manufactured to help the users in adopting different attachments, easily adaptable in accordance with unified rules.

Nota: Tutte le dimensioni indicate, sono espresse in mm.

Note: All dimensions are expressed in mm.

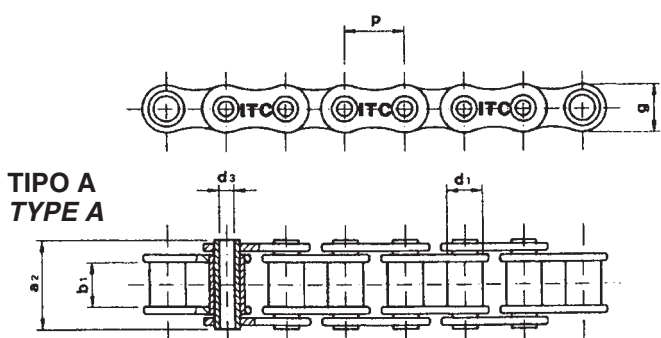

**TIPO A
TYPE A**

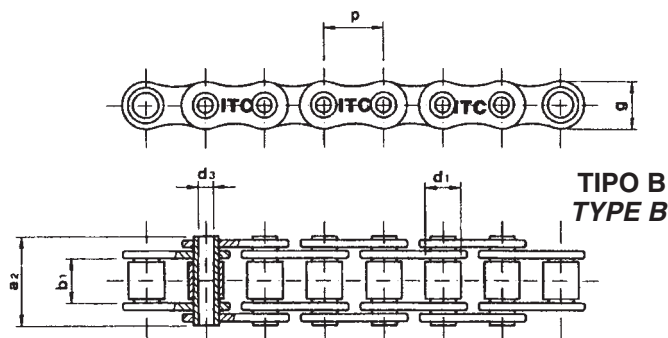

**TIPO B
TYPE B**

ISO N°	p		b1 mm min.	d3 mm	d1 mm max.	a2 mm max.	g mm max.	F _B min N	q kg/m ≈	TIPO TYPE
	mm	inch								
08B-1	12,7	1/2"	7,75	4,5	8,51	16,8	12,2	13.500	0,60	A
10B-1	15,875	5/8"	9,65	5,0	10,16	18,6	14,3	14.500	0,83	A
12B-1	19,05	3/4"	11,68	5,75	12,07	24,0	16,5	18.500	1,05	A
08B-1	12,7	1/2"	7,75	4,40	8,51	17,0	11,7	14.000	0,68	B
10B-1	15,875	5/8"	9,65	5,10	10,16	19,5	14,0	15.000	0,87	B
12B-1	19,05	3/4"	11,68	5,70	12,07	22,5	18,0	21.000	1,10	B
12A-1	19,05	3/4"	12,70	5,97	11,91	25,0	18,0	25.000	1,30	B
16B-1	25,4	1"	17,02	8,10	15,88	36,0	21,0	50.000	2,40	B

TRASPORTO PESANTE / HEAVY TRANSPORT

CATENE NON UNIFICATE NOT UNIFIED CHAINS

CATENE PER TRASPORTATORI CHAINS FOR CONVEYORS

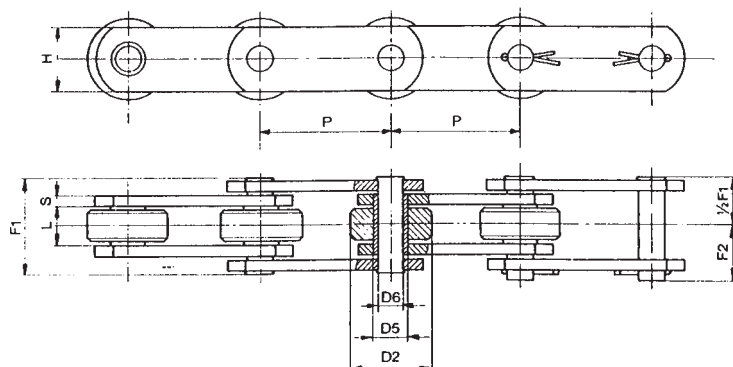

A PERNI PIENI / FULL PINS TYPE

Catena N° Chain N°	P mm	L mm	D2 mm	D5 mm	D6 mm	H mm	S mm	F1 mm	F2 mm	Carico di rottura Medium breaking load N.	Peso catena Weight of chain Kg/m
E 103	50	11,5	25	8,35	5,7	15	2	23,8	14,6	16.000	1,4
E 200	50	11,5	25	8,35	5,7	15	3	27	16,5	18.000	1,7
E 202	69	11,5	25	8,35	5,7	15	3	27	16,5	18.000	1,5
E 203	75	11,5	25	8,35	5,7	20	3	27	16,5	18.000	1,7
E 204	100	11,5	25	8,35	5,7	20	3	27	16,5	18.000	1,4
* E 205	50	11,5	25	8,35	5,7	18	2,5	25,5	15,4	18.000	1,7
• E 205 SS	50	11,5	25	8,35	5,7	18	2,5	25,5	15,4	18.000	1,7
E 206	50	11,5	25	11	8	20	3	28,8	16,5	22.000	1,9
E 206R	50	11,5	25	11	8	20	3	28,8	16,5	45.000	1,9

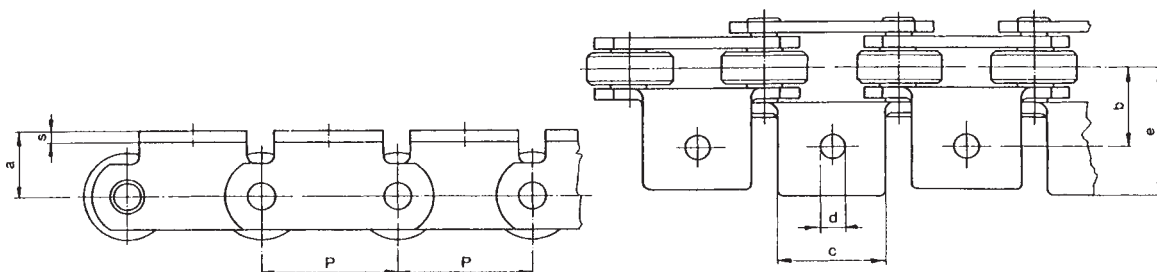

ATTACCHI / ATTACHMENTS

Catena N° Chain N°	P mm	a mm	b mm	c mm	d mm	e mm	s mm	Sovrap. unit. attacco Attachment unitary over weight Kg/m
E 103	50	25	231	41	6,5	32	2	0,023
E 200	50	25	23,5	41	6,5	34	3	0,035
E 202	69	27	24	66	6,5	34	3	0,050
E 203	75	27	34	45,5	6,5	46	3	0,055
▲ E 204	100	27	31	60	7	44	3	0,060
E 205	50	24	22	46	6,5	36	2,5	0,035
E 205 B	50	14	32	46	6,5	45	2,5	0,035
E 205 SS	50	24	22	46	6,5	36	2,5	0,035
E 206	50	24	23	40	6,5	38	3	0,035
E 206R	50	24	23	40	6,5	38	3	0,035

Versioni alternative:

– Rulli in nylon, delrin, etc.

– A perni sporgenti

– Trattamento di zincatura - nichelatura - cadmiatura

* Disponibile anche con perni sporgenti Ø 10x30 mm ogni 100 mm

• Esecuzione in acciaio inossidabile

▲ Attacchi a 3 fori (diametro fori laterali 6,5 mm - interasse fori 35 mm)

Alternative types:

– Nylon rollers, delrin, etc.

– With projecting pins

– Galvanization zinc plating - nichel - plating - cadmiun plating treatment

* Available with projecting pins Ø 10x30 mm each 100 mm

• Stainless steel execution

▲ 3 holes attachments (lateral holes diam. 6,5 mm - distance between centers 35 mm)

TRASPORTO PESANTE / HEAVY TRANSPORT

**CATENE NON UNIFICATE
NOT UNIFIED CHAINS**

**CATENE PER TRASPORTATORI
CHAINS FOR CONVEYORS**

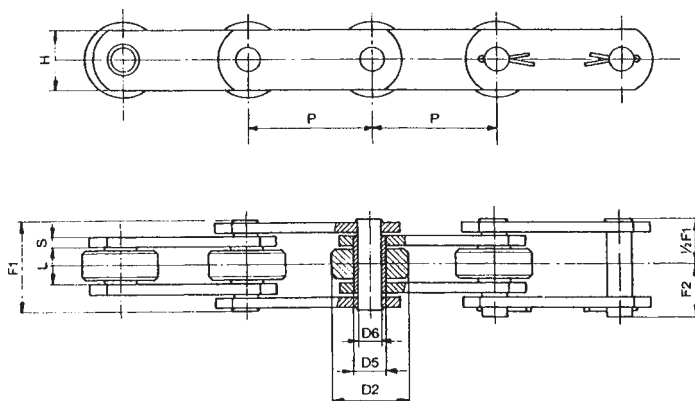

A PERNI PIENI / FULL PINS TYPE

Catena N° Chain N°	P mm	L mm	D2 mm	D5 mm	D6 mm	H mm	S mm	F1 mm	F2 mm	Carico di rottura Medium breaking load N.	Peso catena Weight of chain Kg/m
E 400	50	15	31	13,2	10	23	3	32,6	19,2	35.000	3 *
E 400 SS	50	15	31	13,2	10	23	3	32,6	19,2	30.000	3 **
E 401	75	15	31	13,2	10	25	3	32,6	19,2	35.000	2,8
E 402	100	15	31	13,2	10	25	3	32,6	19,2	35.000	2,3
E 500	50	15	31	13,2	10	25	4	36,6	20,7	45.000	3,9
E 500 R	50	15	31	13,2	10	25	4	36,6	20,7	75.000	3,9
E 501	75	15	31	13,2	10	25	4	36,6	20,7	45.000	3,2
E 502	100	15	31	13,2	10	25	4	36,6	20,7	45.000	2,7
E 503	125	15	31	13,2	10	25	4	36,6	20,7	45.000	2,5
E 504	150	15	31	13,2	10	25	4	36,6	20,7	45.000	2,4
E 701	75	22	40	17	12	35	4	44	25	75.000	5,9
E 703	100	22	40	17	12	35	4	44	25	75.000	4,9
E 704	125	22	40	17	12	35	4	44	25	75.000	4,4
E 705	150	22	60	17	12	35	4	44	25	75.000	4

Versioni alternative:

- Rulli in nylon, delrin, etc.
- A rulli flangiati
- A bussole
- Trattamento di zincatura - nichelatura - cadmiatura
- * Catena a piastre sagomate
- * Esecuzione in acciaio inossidabile
- * Attacchi a 1 foro
- Attacchi a 2 fori
- ▲ Attacchi a 3 fori
- Attacchi saldati

Alternative types:

- Nylon rollers, delrin, etc.
- Flanged rollers
- With sleeves
- Galvanization zinc plating - nichel plating - cadmium plating treatment
- * Chain with shaped plates
- Stainless steel execution
- * 1 hole attachments
- 2 holes attachments
- ▲ 2 holes attachments
- Welded attachments

ATTACCHI / ATTACHMENTS

Catena N° Chain N°	mm	P mm	a mm	b mm	c mm	d mm	d1 mm	e mm	f mm	s mm	Sovrap. unit. attacco Attachment unitary over-weight Kg/m
E 400	* ■	50	32/35	31	60	10	8,5	48,5	25	3	0,080
E 400 B	* ■	50	36,5	31	60	10	8,5	48,5	25	3	0,050
E 400 SS	*	50	35	31	60	10	/	49	/	3	0,080
E 400 SA	*	50	28	31	30	10	/	46	/	3	0,035
E 400 SB	*	50	16,5	42	30	10	/	57	/	3	0,035
E 401	* ■	75	30	28	60	10,5	9	41	30	3	0,060
E 402	▲	100	35	31	70	10	9	47,5	35	3	0,085
E 500	* ■	50	35	32	45	10	8,5	48	25	4	0,070
E 500 B	* ■	50	22	45	45	/	8,5	61	25	4	0,070
E 500 R	■	50	17,5	34	60	10	9	51	30	4	0,070
E 501	▲	75	30	29	60	10	9	43,5	30	4	0,080
E 502	▲	100	35	32	70	10	9	49,2	35	4	0,100
E 503	* ■ ●	125	35	32	70	10	9	56	35	4	0,160
E 504	* ■ ●	150	35	32	100	10	9	56	50	4	0,250
E 701	* ■	75	26	38	50	10	9	70,5	25	4	0,100
E 703	▲	100	40	38	70	10	9	65	35	4	0,140
E 703 B	▲	100	26	38	70	10	9	66	35	4	0,120
E 704	▲	125	26	40	100	10	9	66	70	4	0,150
E 705	* ■ ●	150	26	40	75	10	9	60	50	4	0,180

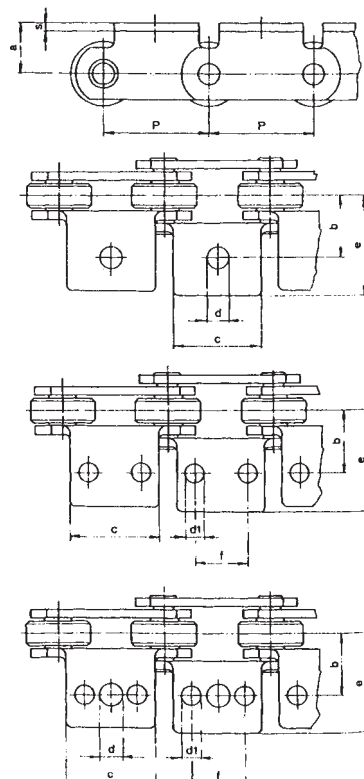

TRASPORTO PESANTE / HEAVY TRANSPORT

CATENE NON UNIFICATE NOT UNIFIED CHAINS

CATENE PER TRASPORTATORI

Nota: Tutte le dimensioni indicate, sono espresse in mm.

CHAINS FOR CONVEYORS

Note: All dimensions are expressed in mm.

A PERNI FORATI

HOLLOW PINS CHAIN

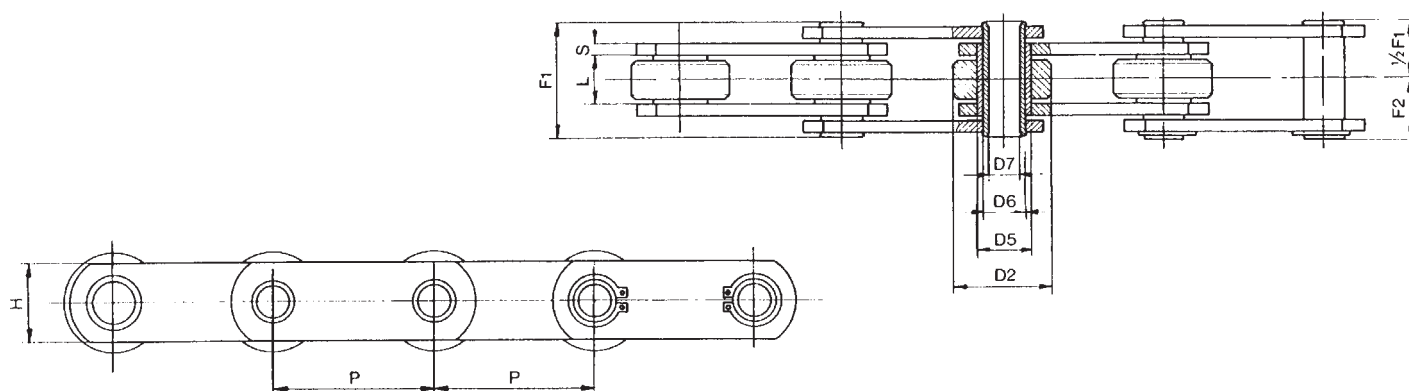

Catena N° Chain N°	P mm	L mm	D2 mm	D5 mm	D6 mm	D7 mm	H mm	S mm	F1 mm	F2 mm	Carico di rottura Medium breaking load N.	Peso catena Weight of chain Kg/m
E 250	50	11,5	25	11	9	6,2	20	2,5	26	14,5	30.000	1,8
E 250 R	50	11,5	25	11	9	6,2	20	2,5	26	14,5	38.000	1,8
• E 250 SS	50	11,5	25	11	9	6,2	20	2,5	26	14,5	25.000	1,8
E 251	75	11,5	25	11	9	6,2	20	2,5	26	14,5	30.000	1,4
E 252	100	11,5	25	11	9	6,2	20	2,5	26	14,5	30.000	1,2
E 400 C	50	15	31	17	14	10,2	25	3	31	17,5	35.000	3
E 500 C	50	15	31	17	14	10,2	25	4	35	19,5	40.000	3,6
E 500 CR	50	15	31	17	14	10,2	25	4	35	19,5	65.000	3,6
E 501 C	75	15	31	17	14	10,2	25	4	35	19,5	40.000	3,1
E 502 C	100	15	31	17	14	10,2	25	4	35	19,5	40.000	2,6
E 503 C	125	15	31	17	14	10,2	25	4	35	19,5	40.000	2,4
E 504 C	150	15	31	17	14	10,2	25	4	35	19,5	40.000	2,3
E 701 C	75	22	40	23	18	12,2	35	4	42	24	60.000	4,6
E 703 C	100	22	40	23	18	12,2	35	4	42	24	60.000	4,6
E 704 C	125	22	40	23	18	12,2	35	4	42	24	60.000	4,2
E 705 C	150	22	40	23	18	12,2	35	4	42	24	60.000	4

Versioni alternative:

– Trattamento di zincatura -
nichelatura - cadmiatura

• Esecuzione in acciaio
inossidabile

Alternative types:

– Galvanization zinc plating -
nichel plating - cadmium
plating treatment

• Stainless steel execution

TRASPORTO PESANTE / HEAVY TRANSPORT

CATENE NON UNIFICATE NOT UNIFIED CHAINS

CATENE PER TRASPORTATORI

Nota: Tutte le dimensioni indicate, sono espresse in mm.

CHAINS FOR CONVEYORS

Note: All dimensions are expressed in mm.

A PIASTRE DISASSATE - NON UNIFICATE

MISALIGNED PLATES - NOT STANDARD

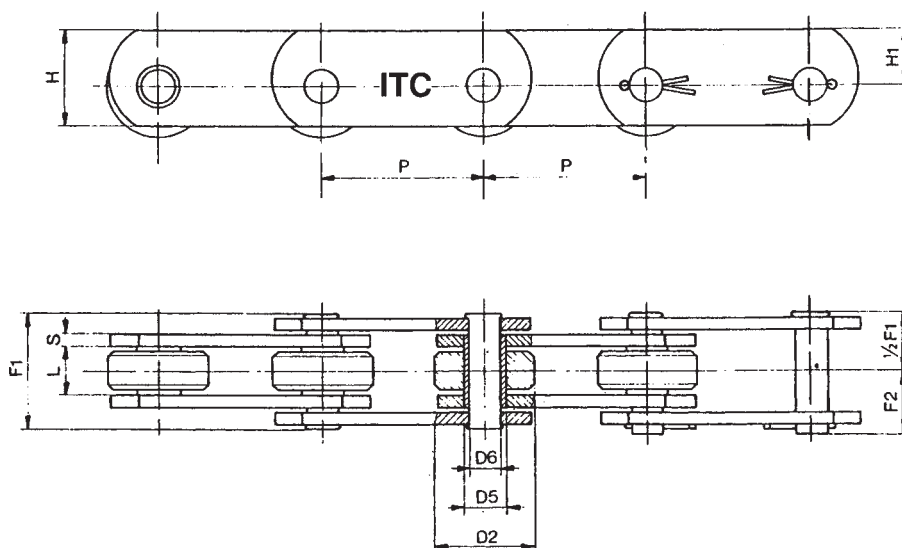

Catena N° Chain N°	P mm	L mm	D2 mm	D5 mm	D6 mm	H mm	H1 mm	S mm	F1 mm	F2 mm	Carico di rottura Medium breaking load N.	Peso catena Weight of chain Kg/m
E 350	50	11,5	18	8,35	5,7	17,5	10	2,5	25,5	15,4	20.000	1,25
E 351	50	11,5	25	8,35	5,7	25	16,5	2	23,8	14,6	20.000	2
E 352	50	15	31	13,2	10	30	17,5	4	36,6	20,7	60.000	4,5
E 353	75	15	31	13,2	10	30	17,5	4	36,6	20,7	60.000	3,8
E 354	100	15	31	13,2	10	30	17,5	4	36,6	20,7	60.000	3,5

Versioni alternative:

- Trattamento di zincatura - nichelatura - cadmiatura

Alternative types:

- Galvanization zinc plating - nichel plating - cadmium plating treatment

CATENE PER ACCUMULO / STORAGE CHAINS

CATENE A RULLI SEMPLICI CON RULLO SUPERIORE FOLLE SINGLE STRAND ROLLER CHAINS WITH IDLE UPPER ROLLER

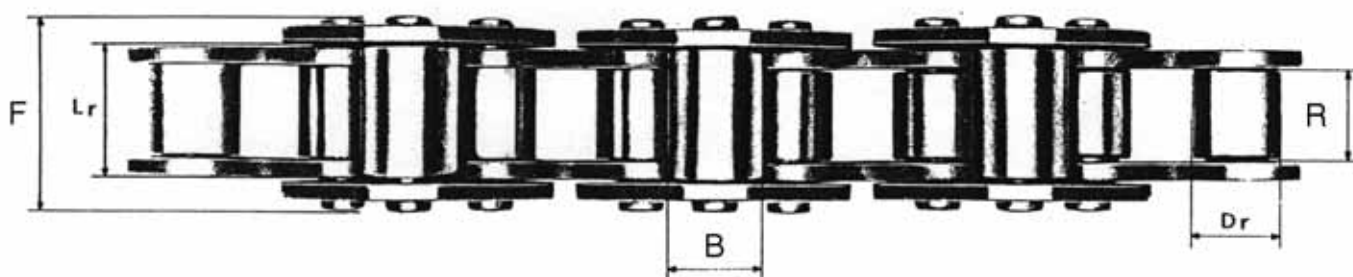
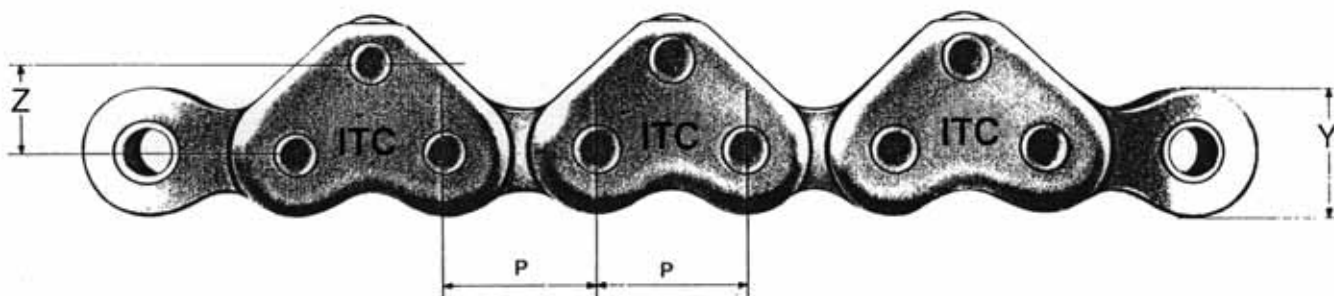

Codice Ref.	Passo Pitch P mm	Largh. interna Width between inner plates R mm	Diam. rullo Roller diameter Dr mm	Altezza piastra Inner plate depth Y mm	Ingombro perno Width over bearing pins F mm	Diam. rullo folle Diameter of idle roller B mm	Larghezza rullo folle Width of idle roller Lr mm	Interasse verticale Vertical distance between centers Z mm	Carico medio di rottura Medium breaking load Kg
E 16-ACC	25,40	17,02	15,88	23,5	35,0	30	24	26	6.500
E 20-ACC	31,75	19,56	19,05	27,2	42,0	20	28	19	8.500

CATENE PER ACCUMULO / STORAGE CHAINS

**CATENE A RULLI SEMPLICI CON RULLO SUPERIORE FOLLE
SINGLE STRAND ROLLER CHAINS WITH IDLE UPPER ROLLER**

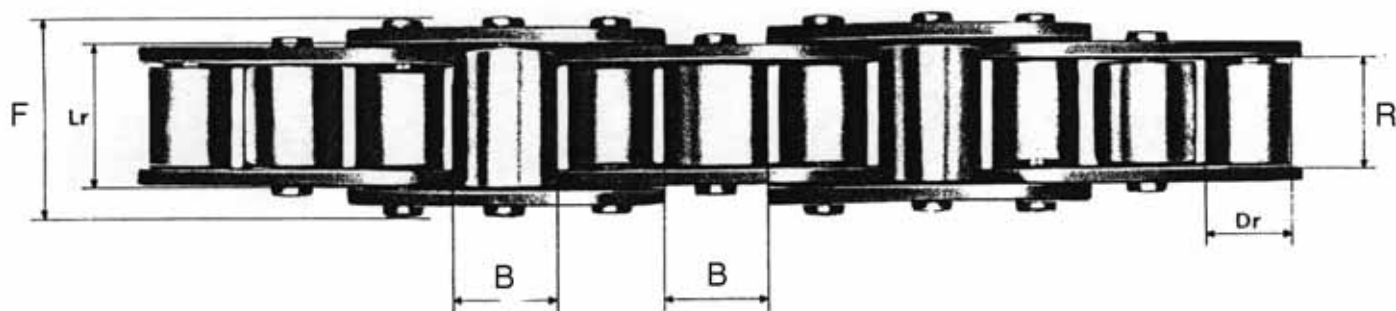
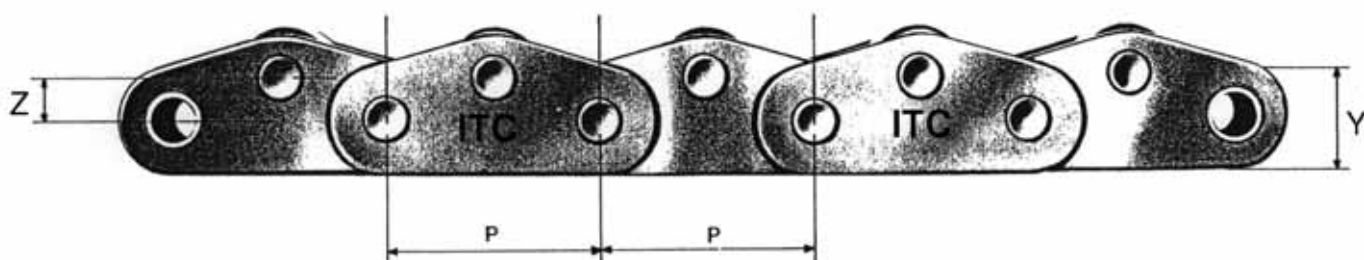

Codice Ref.	Passo Pitch P mm	Largh. interna Width between inner plates R mm	Diam. rullo Roller diameter Dr mm	Altezza piastra Inner plate depth Y mm	Ingombro perno Width over bearing pins F mm	Diam. rullo folle Diameter of idle roller B mm	Larghezza rullo folle Width of idle roller Lr mm	Interasse verticale Vertical distance between centers Z mm	Carico medio di rottura Medium breaking load Kg
E 50-ACC	50	26	20	25	47	24	33	10	4.200

CATENE PER ACCUMULO / STORAGE CHAINS

**CATENE A RULLI SEMPLICI CON RULLO SUPERIORE FOLLE
SINGLE STRAND ROLLER CHAINS WITH IDLE UPPER ROLLER**

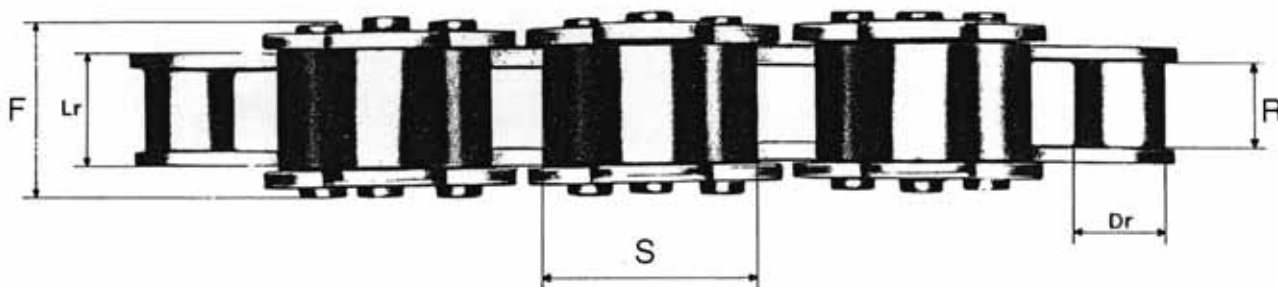
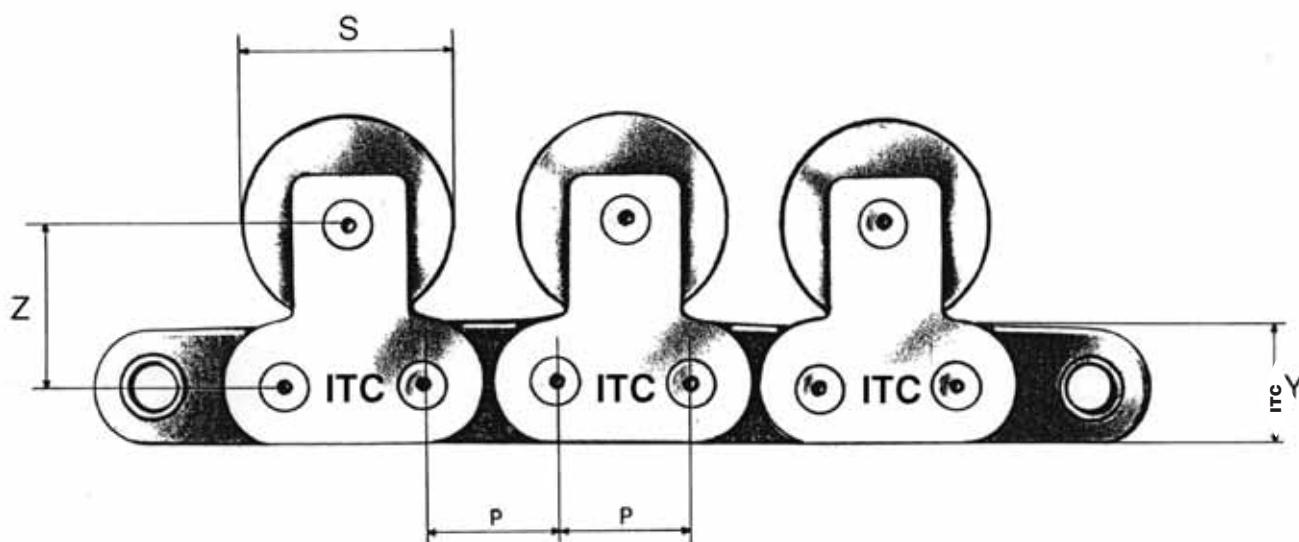

Codice Ref.	Passo Pitch P mm	Largh. interna Width between inner plates R mm	Diam. rullo Roller diameter Dr mm	Altezza piastra Inner plate depth Y mm	Ingombro perno Width over bearing pins F mm	Diam. rullo folle Diameter of idle roller B mm	Larghezza rullo folle Width of idle roller Lr mm	Interasse verticale Vertical distance between centers Z mm	Carico medio di rottura Medium breaking load Kg
E 6-ACC	9,525	5,72	6,35	8,26	13,50	12	8,3	10,2	1.000
E 8-ACC	12,70	7,75	8,51	11,90	16,50	15	10,7	14,5	1.900
E 10-ACC	15,875	9,65	10,16	14,73	19,60	20	13,2	18,8	2.500
E 12-ACC	19,05	11,68	12,07	17,50	22,70	20	15,5	19,5	3.000
E 16-ACC	25,40	17,02	15,88	23,20	36,10	23	24,0	23,6	6.500

CATENE PER ACCUMULO / STORAGE CHAINS

CATENE A RULLI TRIPLA, CON RULLO CENTRALE FOLLE TRIPLE STRAND CHAINS, WITH CENTRAL IDLE ROLLER

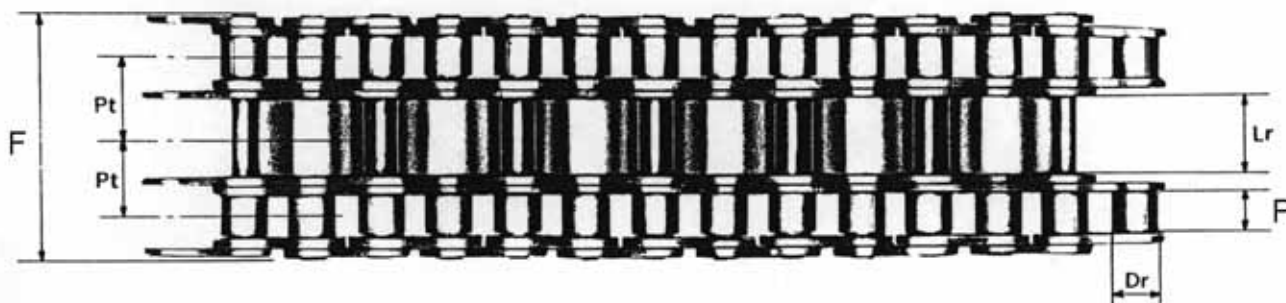
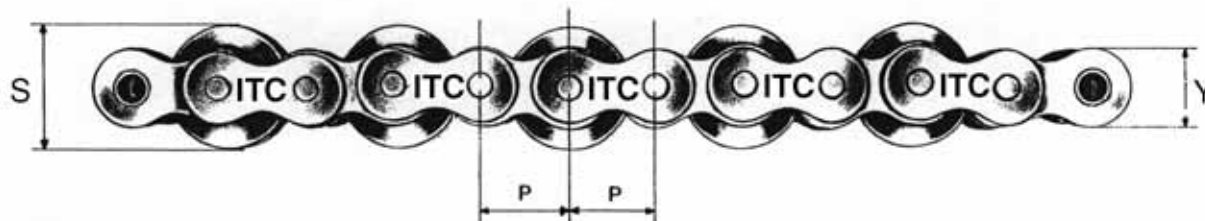

Codice Ref.	Passo Pitch	Largh. interna Width between inner plates R	Diam. rullo Roller diameter Dr	Altezza piastra Inner plate depth Y	Passo trasvers. Transverse pitch Pt	Diam. rullo folle Diameter of idle roller F	Larghezza rullo folle Width of idle roller Lr	Interasse verticale Vertical distance between centers S	Carico medio di rottura Medium breaking load Kg
	P mm	R mm	Dr mm	Y mm	Pt mm	F mm	Lr mm	S mm	Kg
ET 6-ACC	9,525	5,72	6,35	8,26	10,24	34	12	9,0	1.900
ET 8-ACC	12,70	7,75	8,51	11,90	13,92	45	17	13,5	3.600
ET 10-ACC	15,875	9,65	10,16	14,73	16,59	54	23	16,3	5.000
ET 12-ACC	19,05	11,68	12,07	17,50	19,46	62	28	18,6	6.000
ET 16-ACC	25,40	17,02	15,88	21,00	31,88	99	35	32,0	13.200
ET 24-ACC	38,10	25,40	25,40	35,80	48,36	152	45	47,0	29.000

CATENE PER ACCUMULO / STORAGE CHAINS

CATENE PER TRASPORTATORI, CON TRE RULLI FOLLI
CONVEYORS CHAINS, WITH THREE IDLE ROLLERS

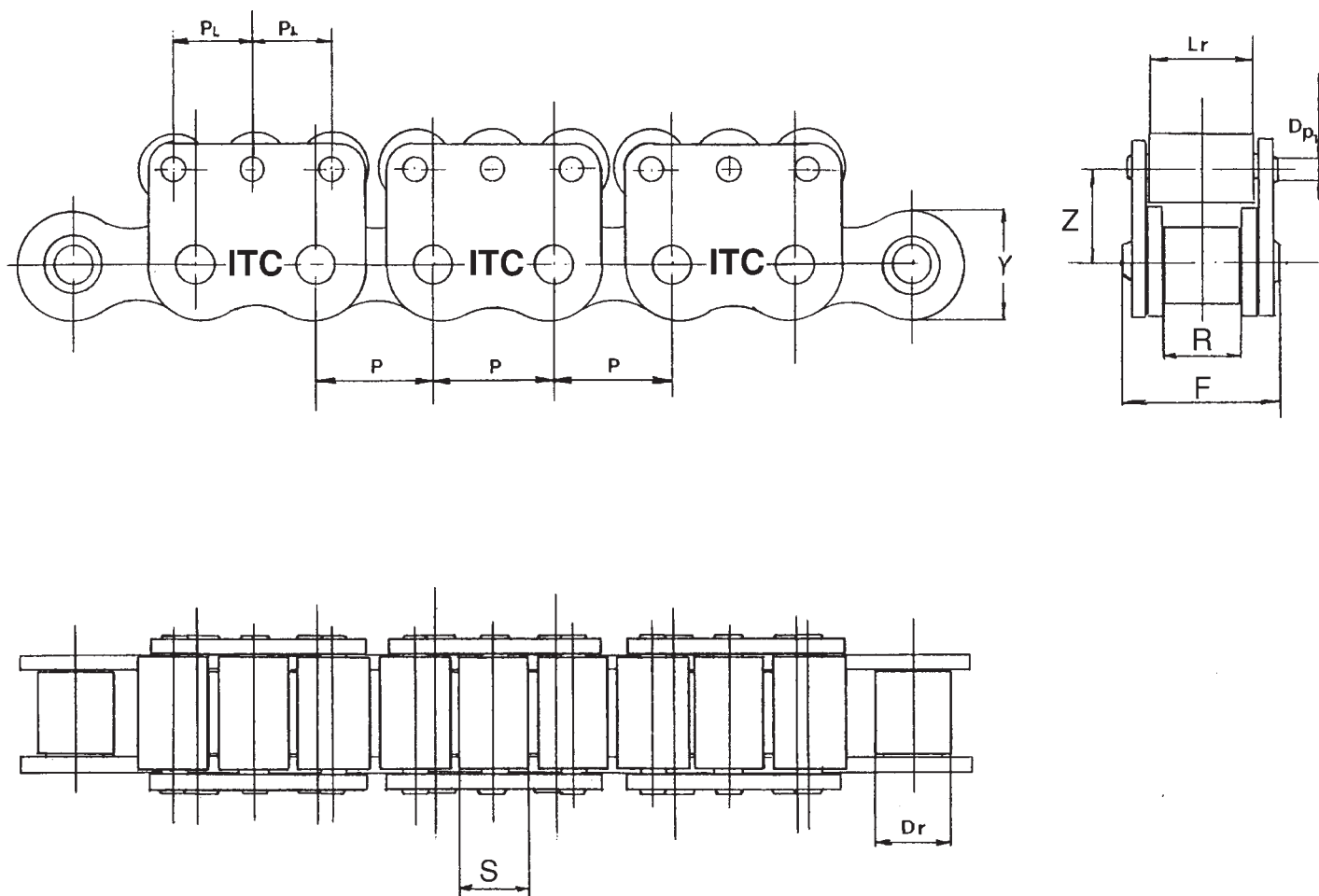

Codice Ref.	Passo Pitch P mm	Largh. interna Width between inner plates R mm	Diam. rullo Roller diameter Dr mm	Altezza piastra Inner plate depth Y mm	Ingombro perno Width over bearing pins F mm	Diam. rullo folle Diameter of idle roller S mm	Largh. rullo folle Width of idle roller Lr mm	Interasse verticale Vertical distance between centers Z mm	Interasse longitud. Longitudinal distance between centers Pl mm	Diam. perno sup. Upper pin diameter Dp1 mm	Carico medio di rottura Medium breaking load Kg
E 316-ACC	25,4	17,02	15,88	23,5	35	15	24	19,9	16,5	5,05	6.500



TRAZIONE / TRACTION

CATENE FLEYER A PIASTRE MULTIPLE FLEYER CHAINS WITH MULTIPLE PLATES

Nota: Tutte le dimensioni indicate, sono espresse in mm.

Note: All dimensions are expressed in mm.

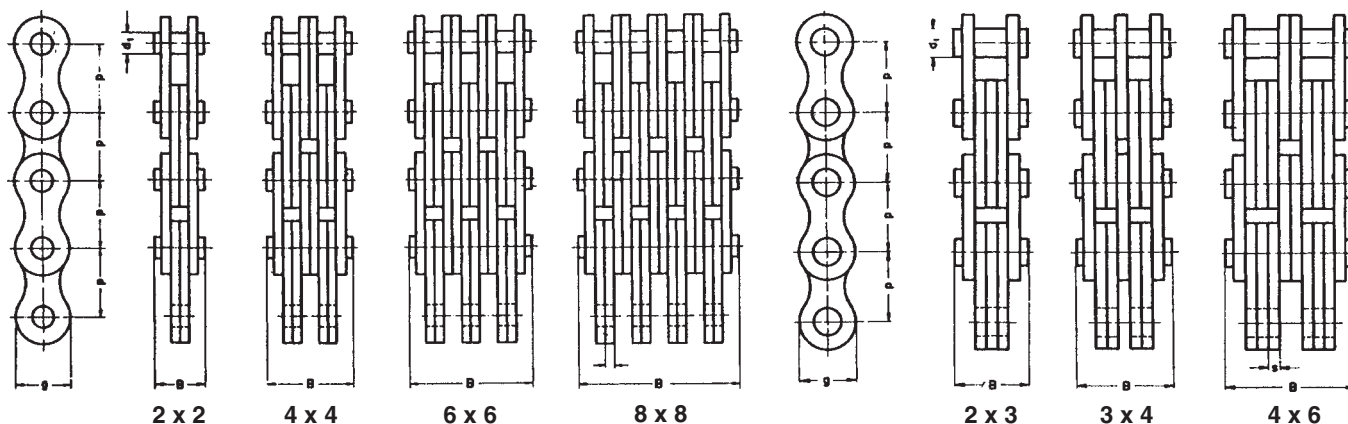

Catena tipo Type	Passo Pitch P Pollici / Inches mm	Composizione piastre Lacing	Diam. perno Max pin diam. d ₁ max mm	Altezza piastre Max plate depth g max. mm	Spessore piastre Plate thickness s mm	Larghezza catena Max chain width B mm	Superficie di lavoro Working surface cm ²	Carico di rottura minimo Min. breaking load N	Peso Weight kg/m
Catene Fleyer, serie americana (AL) / Fleyer chains american series (AL)									
AL 422		2 x 2				8,1	0,12	14.100	0,35
AL 444	1/2	4 x 4	3,96	10,2	1,5	14,5	0,23	28.200	0,67
AL 466		6 x 6				20,9	0,35	42.300	1,0
AL 522		2 x 2				10,5	0,2	22.000	0,63
AL 544	5/8	4 x 4	5,08	12,8	2,0	18,7	0,4	44.000	1,2
AL 566		6 x 6				27,1	0,6	66.000	1,75
AL 622		2 x 2				12,6	0,28	37.000	0,93
AL 644		4 x 4				22,5	0,57	63.600	1,6
AL 666	3/4	6 x 6	5,94	14,8	2,4	32,0	0,85	95.400	2,5
AL 688		8 x 8				43,0	1,14	127.200	3,3
AL 844		4 x 4				30,8	1,01	113.400	3,3
AL 866	1	6 x 6	7,92	20,5	3,05	44,4	1,52	170.000	4,9
AL 1044		4 x 4				37,3	1,52	177.000	4,9
AL 1066	1 1/4	6 x 6	9,53	25,7	4,0	54,0	2,29	265.500	7,3
AL 1266		6 x 6				63,3	3,12	381.000	10,5
AL 1288	1 1/2	8 x 8	11,1	29,4	4,7	83,0	4,17	508.000	14,0
AL 1466	1 3/4	6 x 6	12,7	36,0	5,5	74,5	4,2	558.000	13,0
AL 1666	2	6 x 6	14,27	41,2	6,3	85,0	5,39	642.000	18,0

TRAZIONE / TRACTION

CATENE FLEYER A PIASTRE MULTIPLE

FLEYER CHAINS WITH MULTIPLE PLATES

Nota: Tutte le dimensioni indicate, sono espresse in mm.

Note: All dimensions are expressed in mm.

Catena tipo Type	Riferimento Ref. DIN	Passo Pitch P		Composizione piastre Lacing	Diam. perno Max pin diam. d, max mm	Altezza piastre Max plate depth g max. mm	Spessore piastre Plate thickness s mm	Larghezza catena Max chain width B mm	Superficie di lavoro Working surface cm ²	Carico di rottura minimo Min. breaking load N	Peso Weight kg/m
		Pollici / Inches	mm								
Catene Fleyer, serie americana (BL) / Fleyer chains american series (BL)											
BL 423	LH 0823			2 x 3				12,4	0,3	22.200	0,65
BL 434	LH 0834			3 x 4				16,7	0,41	33.300	0,9
BL 444	LH 0844	1/2	12,7	4 x 4	5,08	11,6	1,95	18,7	0,41	44.400	1,02
BL 446	LH 0846			4 x 6				22,8	0,61	44.400	1,26
BL 466	LH 0866			6 x 6				27,1	0,61	66.600	1,51
BL 523	LH 1023			2 x 3				14,8	0,43	32.600	0,9
BL 534	LH 1034			3 x 4				19,9	0,57	48.900	1,32
BL 544	LH 1044	5/8	15,875	4 x 4	5,94	14,6	2,35	22,5	0,57	65.200	1,51
BL 546	LH 1046			4 x 6				27,4	0,86	65.200	1,86
BL 566	LH 1066			6 x 6				32,0	0,86	97.800	2,24
BL 623	LH 1223			2 x 3				19,7	0,76	48.900	1,76
BL 634	LH 1234			3 x 4				26,4	1,0	73.400	2,43
BL 644	LH 1244	3/4	19,05	4 x 4	7,92	17,8	3,1	29,5	1,0	97.800	2,76
BL 646	LH 1246			4 x 6				35,9	1,5	97.800	3,43
BL 666	LH 1266			6 x 6				42,4	1,5	146.700	4,1
BL 823	LH 1623			2 x 3				24,6	1,11	84.500	3,0
BL 834	LH 1634			3 x 4				33,1	1,48	126.700	4,15
BL 844	LH 1644	1	25,4	4 x 4	9,53	23,6	4,0	37,4	1,48	169.000	4,72
BL 846	LH 1646			4 x 6				45,5	2,22	169.000	5,86
BL 866	LH 1666			6 x 6				54,0	2,22	253.500	7,0
BL 1023	LH 2023			2 x 3				28,6	1,56	115.700	4,35
BL 1034	LH 2034			3 x 4				38,7	2,09	173.600	6,05
BL 1044	LH 2044	1 1/4	31,75	4 x 4	11,1	29,2	4,7	43,6	2,09	231.400	6,9
BL 1046	LH 2046			4 x 6				53,3	3,12	231.400	8,5
BL 1066	LH 2066			6 x 6				63,3	3,12	347.200	10,25
BL 1223	LH 2423			2 x 3				33,6	2,1	151.200	5,8
BL 1234	LH 2434			3 x 4				45,5	2,79	226.800	8,0
BL 1244	LH 2444	1 1/2	38,1	3 x 4	12,7	34,4	5,5	51,2	2,79	302.400	9,1
BL 1246	LH 2446			4 x 6				62,7	4,2	302.400	11,4
BL 1266	LH 2466			6 x 6				74,5	4,2	453.600	13,6
BL 1288	LH 2488			8 x 8				97,8	5,4	604.800	17,9
BL 1423	LH 2823			2 x 3				38,2	2,7	191.300	7,9
BL 1434	LH 2834			3 x 4				51,7	3,6	286.900	11,0
BL 1444	LH 2844	1 3/4	44,45	4 x 4	14,27	40,8	6,3	58,2	3,6	382.600	12,6
BL 1446	LH 2846			4 x 6				71,5	5,4	382.600	15,7
BL 1466	LH 2866			6 x 6				85,0	5,4	642.000	18,8
BL 1623	LH 3223			2 x 3				42,1	3,8	289.100	9,0
BL 1634	LH 3234			3 x 4				57,0	5,0	433.600	12,5
BL 1646	LH 3246	2	50,8	4 x 6	17,46	47,9	7,0	78,9	7,6	578.200	17,8
BL 1666	LH 3266			6 x 6				93,8	7,6	867.200	21,3
BL 1688	LH 3288			8 x 8				123,3	10,0	1.156.400	28,3

TRAZIONE / TRACTION

CATENE FLEYER A PIASTRE MULTIPLE

FLEYER CHAINS WITH MULTIPLE PLATES

Nota: Tutte le dimensioni indicate, sono espresse in mm.

Note: All dimensions are expressed in mm.

Catena tipo Type	Riferimento Ref. DIN	Passo Pitch P		Composizione piastre Lacing	Diam. perno Max. pin diam. d ₁ max mm	Altezza piastre Max. plate depth g max. mm	Spessore piastre Plate thickness s mm	Larghezza catena Pin len B mm	Superficie di lavoro Working surface cm ²	Carico di rottura minimo Min. breaking load N	Peso Weight kg/m
		Pollici / Inches	mm								
Catene Fleyer, serie europea / Fleyer chains, european series											
UF 922	–			2 x 2				8,0		12.000	0,20
UF 944	–	3/8	9,52	4 x 4	3,60	7,0	1,30	12,8		23.000	0,40
UF 966	–			6 x 6				18,5		35.000	0,60
UF 988	–			8 x 8				24,0		46.000	0,80
UF 1222	LL 0822			2 x 2						7,9	
F12-44	LL 0844	1/2	12,7	4 x 4	4,45	10,2	1,4	16,1	0,28	36.400	0,82
F12-66	LL 0866			6 x 6				23,4	0,42	54.600	1,2
UF 1288	–			8 x 8				25,9		72.000	1,50
UF 1522	LL 1022			2 x 2					8,9		25.000
F15-44	LL 1044	5/8	15,875	4 x 4	5,08	12,8	1,63	14,9	0,32	45.400	0,94
F15-66	LL 1066			6 x 6				21,4	0,48	68.100	1,4
UF 1588	–			8 x 8				29,3		100.000	1,90
UF 1922	LL 1222			2 x 2					10,5		28.000
UF 1944	LL 1244	3/4	19,05	4 x 4	5,72	16,8	1,75	15,5		60.000	1,30
UF 1966	LL 1266			6 x 6				23,6		92.000	1,95
UF 1988	–			8 x 8				31,5		122.000	2,60
UF 2522	LL 1622			2 x 2					16,0		65.000
F25-44	LL 1644	1	25,4	4 x 4	8,28	20,5	3,05	29,1	0,99	116.000	2,8
F25-66	LL 1666			6 x 6				41,7	1,49	174.000	4,2
F25-88	LL 1688			8 x 8				54,8	1,98	232.000	5,2
F31-44	LL 2044			4 x 4							33,3
F31-66	LL 2066	1 1/4	31,75	6 x 6	10,19	25,7	3,5	48,2	2,12	285.000	6,3
F31-88	LL 2088			8 x 8				63,2	2,83	380.000	8,4
F38-44	LL 2444	4 x 4				46,9	2,91	340.000	8,2		
F38-66	LL 2466	1 1/2	38,1	6 x 6	14,63	33,0	5,0	68,3	4,37	510.000	12,0
F38-88	LL 2488			8 x 8				89,7	5,82	680.000	16,3
F44-22	LL 2822	2 x 2				29,4	1,9	200.000	4,8		
F44-44	LL 2844	1 3/4	44,45	4 x 4	15,9	36,0	6,0	54,7	3,8	400.000	9,5
F44-66	LL 2866			6 x 6				80,2	5,7	600.000	14,1
F50-22	LL 3222	2 x 2				31,8	2,24	260.000	6,2		
F50-44	LL 3244	2	50,8	4 x 4	17,81	41,2	6,3	59,1	4,47	520.000	11,9
F50-66	LL 3266			6 x 6				85,4	6,71	780.000	17,8
F50-88	LL 3288			8 x 8				112,0	8,94	1.040.000	23,8
F63-22	LL 4022			2 x 2							39,5
F63-44	LL 4044	2 1/2	63,5	4 x 4	22,89	48,0	8,0	73,1	7,3	720.000	17,9
F63-66	LL 4066			6 x 6				106,5	10,94	1.080.000	26,6
F76-44	LL 4844	4 x 4				91,2	11,66	1.120.000	29,6		
F76-66	LL 4866	3	76,2	6 x 6	29,24	62,0	10,0	131,0	17,5	1.680.000	44,0
F 1016	–			5/8				15,875	2 x 2	5,08	12,8
F 1316	–	–	20,637	2 x 2	7,13	18,4	3,0	23,1	0,48	57.500	1,5

TRAZIONE / TRACTION

ATTACCHI PER CATENE FLEYER/PIASTRE INTERNE ATTACHMENTS FOR FLEYER CHAINS/INNER PLATES

Nota: Tutte le dimensioni indicate, sono espresse in mm.

Note: All dimensions are expressed in mm.

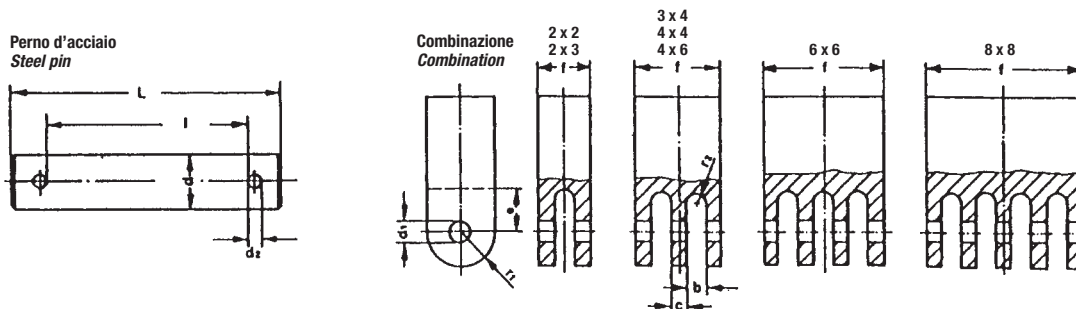

**PERNI D'ATTACCO PER CATENE FLEYER
ATTACHMENT PINS FOR FLEYER CHAINS**

Catena Tipo Type	L max. mm	l min. mm	d max. mm	d ₂ mm
BL422/AL522	15,00	9,00		
BL423	17,40	9,3		
BL434	23,00	18,00		
BL444/AL544	25,00	19,00	5,08	1,6
BL446	28,50	22,50		
BL466/AL566	33,50	27,50		
BL488/AL588	41,80	35,80		
BL522	17,00	10,05		
BL523	19,00	12,00		
BL534	23,00	17,5		
BL544/AL644	29,00	22,5	5,94	2,0
BL546	33,50	27,10		
BL566/AL666	36,50	28,90		
BL588/AL688	49,30	43,10		
BL623	25,50	17,50		
BL634	32,50	23,50		
BL644/AL844	34,50	26,00	7,92	3,2
BL646	42,00	33,50		
BL666/AL866	53,50	43,00		
BL688	67,00	56,20		
BL823	35,50	26,00		
BL834	40,70	30,00		
BL844/AL1044	47,80	37,10	9,53	3,2
BL846	52,00	41,50		
BL866/AL1066	64,00	54,00		
BL888/AL1088	76,00	65,00		
BL1023	36,50	25,00		
BL1034	46,50	35,00		
BL1044/AL1244	52,00	41,00	11,10	4,0
BL1046	63,00	52,00		
BL1066/AL1266	75,50	62,50		
BL1088/AL1288	95,00	82,00		
BL1223	42,00	29,00		
BL1234	53,00	40,00		
BL1244/AL1444	59,00	45,50	12,7	4,0
BL1246	71,00	56,00		
BL1266/AL1466	82,00	68,00		
BL1288/AL1488	111,00	99,00		
BL1423	46,00	32,00		
BL1434	59,50	45,00		
BL1444	69,50	55,00	14,27	4,0
BL1446	79,00	65,00		
BL1466	98,00	85,00		
BL1623	55,80	38,00		
BL1634	71,00	52,00		
BL1644	78,00	61,00	17,46	5,0
BL1646	93,00	76,00		
BL1666	109,00	92,00		
BL1688	139,50	120,00		

**DIMENSIONI CONSIGLIATE PER PETTINE
(MATERIALE 590 N/MM²)
SUGGESTED DIMENSIONS FOR CHASER
(MATERIAL 590 N/MM²)**

f max. mm	b min. mm	c max. mm	d ₁ mm	e min. mm	r ₁ max. mm	r ₂ max. mm
10,7	4,2	—				2,0
12,6	6,4	—				3,0
16,9	4,2	2,0				2,0
18,9	4,2	4,0	5,15	9,0	6,5	2,0
22,9	6,4	4,0				3,0
26,9	4,2	4,0				2,0
35,4	4,2	4,0				2,0
12,7	5,0	—				2,0
14,9	7,5	—				3,0
19,9	5,0	2,4				2,0
22,4	5,0	4,8	6,0	11,0	8,0	2,0
26,9	7,5	4,8				3,0
31,9	5,0	4,8				2,0
42,4	5,0	4,8				2,0
19,9	10,3	—				5,0
26,9	6,8	3,2				3,0
29,9	6,8	6,4				3,0
36,9	10,3	6,4	8,0	14,0	9,5	5,0
42,9	6,8	6,4				3,0
56,4	6,8	6,4				3,0
24,9	12,8	—				6,0
32,9	8,5	4,0				4,0
36,9	8,5	8,0				4,0
45,9	12,8	8,0	9,6	18,0	12,5	6,0
52,9	8,5	8,0				4,0
69,4	8,5	8,0				4,0
29,8	15,1	—				7,0
39,0	10,0	4,7				5,0
44,0	10,0	9,4				5,0
54,0	15,1	9,4	11,2	22,0	15,0	7,0
63,0	10,0	9,4				5,0
79,7	10,0	9,4				5,0
34,3	17,7	—				8,0
46,0	11,8	5,5				5,0
49,0	11,8	11,0				5,0
63,3	17,7	11,0	12,8	26,0	19,0	8,0
75,1	11,8	11,0				5,0
98,4	11,8	11,0				5,0
38,5	20,1	—				10,0
52,0	13,4	6,3				6,0
58,4	13,4	12,6				10,0
71,5	20,1	12,6	14,35	31,0	22,0	10,0
84,9	13,4	12,6				10,0
42,8	22,5	—				10,0
57,7	15,0	7,1				7,0
65,4	15,0	14,2				7,0
79,6	22,5	14,2	17,5	34,0	25,0	10,0
94,3	15,0	14,2				7,0
123,7	15,0	14,2				7,0

AGRICOLTURA / AGRICULTURE

CATENE A RULLI “SERIE AMERICANA RINFORZATA” (ANSI H) “AMERICAN REINFORCED SERIES” ROLLER CHAINS (ANSI H)

Derivate dalle catene a rulli “Serie Americana”, sono distinguibili da queste, esclusivamente per lo spessore delle piastre.

Lo spessore delle piastre delle catene sotto raffigurate, fa sì che quest’ultime, vengano preferite all’impiego di trasmissioni con carichi a strappi, assai valide per l’impiego agricolo, nelle fresatrici ad esempio.

Non si tratta di catene con unificazione ISO.

The thickness of plates, marks the difference for these reinforced chains from the “American series” from which they derive. The thickness of chain plates, indicated below, grants a greater adaptability in transmissions with tearing loads: they are particularly used in agricultural sector, milling machines. These chains are not ISO unified.

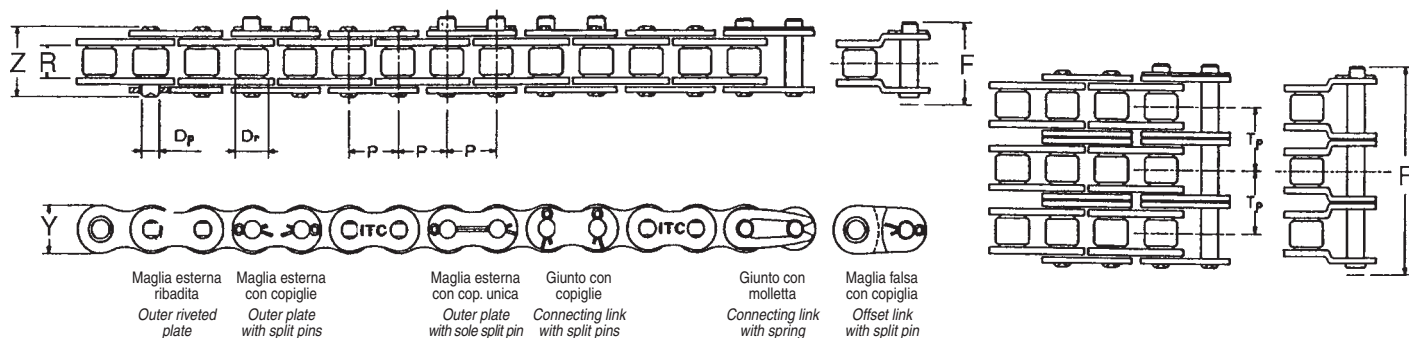

SERIE AMERICANA RINFORZATA (ANSI H) / REINFORCED AMERICAN SERIES (ANSI H)

	ANSI B29-1	Passo Pitch P mm	Diam. rullo max. Max. roller diam. Dr mm	Largh. Int. min. Width between inner plates R mm	Diam. perno max. Max. pin diam. Dp mm	Altezza piastra max. Inner plate depth Y mm	Passo trasv. Transverse pitch Tp mm	Largh. catena ribad. max. Max. width over connecting pins Z mm	Ingombro catena max. Max. width over bearing pins F mm	Superf. di lavoro Working surface mm ²	Carico di rottura medio Medium breaking load N	Peso approx. Approx. weight Kg/m
A 60H	60 H	19,05	11,91	12,70	5,94	18,08	26,30	29,50	38,7	115	36.100	1,70
A 60H-2		19,05	11,91	12,70	5,94	18,08	26,30	55,5	64,7	230	72.300	3,40
A 80H	80 H	25,40	15,88	15,88	7,92	24,13	32,80	36,5	47,3	190	62.700	2,98
A 80H-2		25,40	15,88	15,88	7,92	24,13	32,80	69,5	80,3	380	125.500	5,91
A 80H-3		25,40	15,88	15,88	7,92	24,13	32,80	102,3	113,1	570	188.000	8,84
A 100H	100 H	31,75	19,05	19,05	9,53	30,18	39,35	44,0	56,2	275	103.000	4,35
A 100H-2		31,75	19,05	19,05	9,53	30,18	39,35	83,0	95,2	550	205.600	8,64
A 100H-3		31,75	19,05	19,05	9,53	30,18	39,35	122,5	134,7	325	309.000	12,93
A 120H	120 H	38,10	25,40	25,40	11,10	36,20	49,20	54,0	67,2	410	146.700	6,50
A 120H-2		38,10	25,40	25,40	11,10	36,20	49,20	103,2	116,2	820	293.000	12,88
A 120H-3		38,10	25,40	25,40	11,10	36,20	49,20	152,4	165,5	1230	439.000	19,26
A 140H	140 H	44,45	25,40	25,40	12,70	42,24	52,60	58,0	72,8	495	197.800	8,20
A 140H-2		44,45	25,40	25,40	12,70	42,24	52,60	110,5	125,3	990	396.000	16,70
A 140H-3		44,45	25,40	25,40	12,70	42,24	52,60	163,0	177,8	1485	594.000	24,40
A 160H	160 H	50,80	31,75	31,75	14,27	48,26	61,80	68,0	83,8	665	249.200	10,41
A 160H-2		50,80	31,75	31,75	14,27	48,26	61,80	129,8	145,6	1330	498.500	20,65
A 160H-3		50,80	31,75	31,75	14,27	48,26	61,80	192,0	207,8	1995	747.000	30,89
A 200H	200 H	63,50	38,10	38,10	19,84	60,33	78,30	84,9	101,4	1130	409.000	18,12

AGRICOLTURA / AGRICULTURE

SERIE AGRICOLA EUROPA (ISO) EUROPEAN AGRICULTURAL SERIES (ISO)

Nota: Tutte le dimensioni indicate, sono espresse in mm.

Note: All dimensions are expressed in mm.

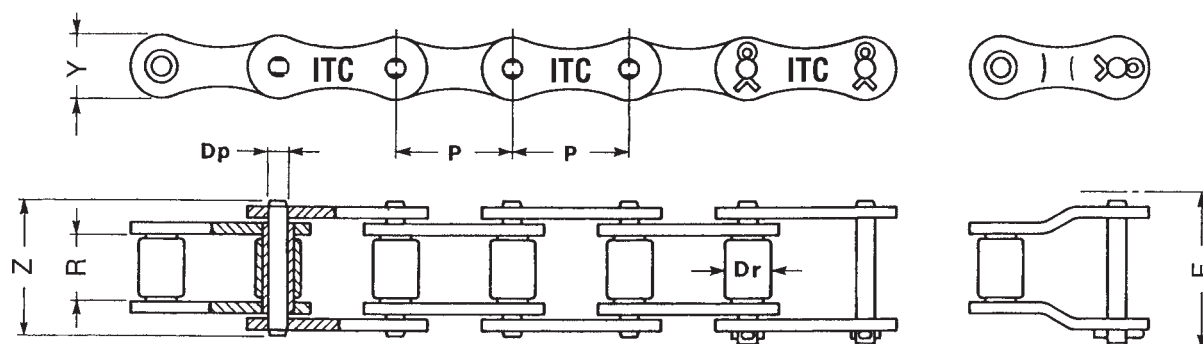

CATENE ANCO / ANCO CHAINS

ISO N°	Passo Pitch P mm	Diam. rullo max. Max. roller diam. Dr mm	Largh. Int. min. Width between inner plates R mm	Diam. perno max Max. pin diam. Dp mm	Altezza piastra max Inner plate depth Y mm	Largh. perno ribad. Width over riveted pin Z mm	Ingombro catena max Max. width over bearing pins F mm	Superf. di lavoro Working surface mm ²	Carico di rottura medio Medium breaking load N	Peso approx Approx. weight Kg/m
S 32	29,21	11,43	15,88	4,47	13,50	26,6	31,8	90	20.800	0,75
S 42	34,93	14,27	19,05	7,01	19,80	34,0	39,4	177	42.700	1,60
S 45	41,40	15,24	22,23	5,74	17,30	37,7	43,2	163	33.270	1,46
S 51	38,10	15,24	16,00	5,74	17,30	31,5	35,0	120	33.270	1,10
S 52	38,10	15,24	22,23	5,74	17,30	37,7	43,2	163	33.270	1,56
S 55	41,40	17,78	22,23	5,74	17,30	37,7	43,2	163	33.270	1,65
S 62	41,91	19,05	25,40	5,74	17,30	40,4	45,7	182	33.270	1,87
S 77	58,34	18,26	22,23	8,92	26,20	43,2	52,1	277	84.400	2,60
S 88	66,27	22,86	28,58	8,92	26,20	50,8	58,4	334	84.400	3,25

AGRICOLTURA / AGRICULTURE

**SERIE AGRICOLA EUROPA (ISO)
EUROPEAN AGRICULTURAL SERIES (ISO)**

Nota: Tutte le dimensioni indicate, sono espresse in mm.

Note: All dimensions are expressed in mm.

**ATTACCHI PER TRASPORTATORI MIETITREBBIA
ATTACHMENTS FOR COMBINE HARVESTER CONVEYORS**

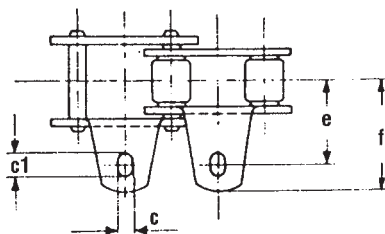
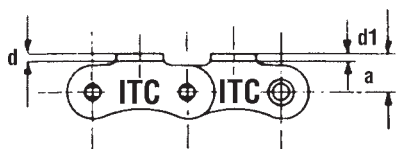

E1

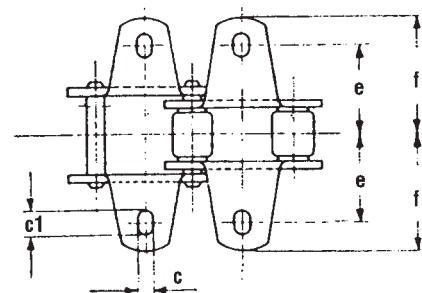

EK1

PER CATENA N° FOR CHAIN N°	Passo Pitch	a mm	c mm	c1 mm	d mm	d1 mm	e mm	f mm
	P mm							
S 32	29,21	8,6	5,3	8,0	1,70	1,70	21,5	30,5
S 42	34,93	14,0	8,3	12,5	2,50	2,50	27,0	37,5
S 45	41,40	11,4	8,5	11,7	2,50	2,50	27,0	37,5
S 51	38,10	11,4	8,5	10,1	2,50	2,50	24,9	34,0
S 52	38,10	11,4	8,5	10,1	2,50	2,50	29,4	38,8
S 55	41,40	11,4	8,5	11,7	2,50	2,50	27,0	37,5
S 62	41,91	11,4	8,5	15,0	2,50	2,50	33,3	47,7
S 77	58,34	20,8	8,5	11,7	4,00	4,00	38,1	50,9
S 88	66,27	20,8	8,5	10,1	4,00	4,00	48,4	59,8

AGRICOLTURA / AGRICULTURE

**SERIE AGRICOLA EUROPA (ISO)
EUROPEAN AGRICULTURAL SERIES (ISO)**

Nota: Tutte le dimensioni indicate, sono espresse in mm.

Note: All dimensions are expressed in mm.

**ATTACCHI PER ELEVATORI, MIETITREBBIA
ATTACHMENTS FOR COMBINE HARVESTER, ELEVATORS**

Tipo EM-35 EM-1 / Type EM-35 EM-1

PER CATENA N° FOR CHAIN N°	Passo Pitch		c ¹ mm	d mm	d ¹ mm	e mm	f mm	Sovrappeso unitario approx. Approx. unitary over weight	
	P mm	c mm						attacco/attachment M-35 Kg	attacco/attachment M-1 Kg
S 32	29,21	5,3	8,0	1,70	1,70	17,5	26,2	0,005	0,010
S 42	34,93	8,3	12,5	2,50	2,50	23,6	34,3	0,009	0,018
S 45	41,40	8,5	11,7	2,50	2,50	19,8	30,2	0,011	0,022
S 51	38,10	8,5	10,1	2,50	2,50	19,8	31,8	0,010	0,020
S 52	38,10	8,5	10,1	2,50	2,50	22,1	31,8	0,010	0,020
S 55	41,40	8,5	11,7	2,50	2,50	19,8	30,2	0,011	0,022
S 62	41,91	8,5	15,0	2,50	2,50	24,6	38,6	0,013	0,026
S 77	58,34	8,5	11,7	4,00	4,00	36,3	50,0	0,020	0,040
S 88	66,27	8,5	10,1	4,00	4,00	43,7	55,6	0,024	0,044

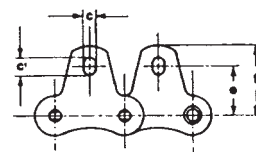

EM - 35

EM - 1

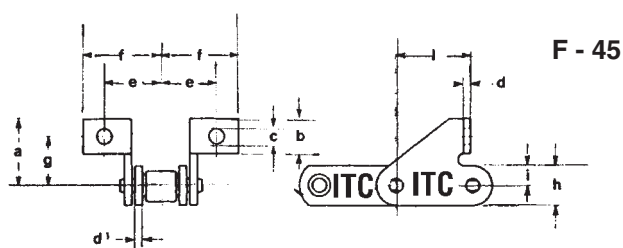
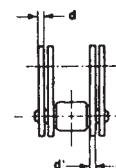
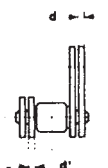

F - 45

Tipo F-45 / Type F-45

PER CATENA N° FOR CHAIN N°	Tipo di attacco Type of attachment	Passo Pitch													Sovrappeso unitario approx. attacco Approx. unitary over weight attachment F-1 Kg
		P mm	a mm	b mm	c mm	d mm	d ¹ mm	e mm	f mm	g mm	h mm	i mm	l mm		
CA 39	F 45	38,40	34,50	21,00	8,40	2,50	2,50	25,75	34,90	24,00	17,20	8,60	37,50	0,036	

AGRICOLTURA / AGRICULTURE

**SERIE AGRICOLA EUROPA (ISO)
EUROPEAN AGRICULTURAL SERIES (ISO)**

Nota: Tutte le dimensioni indicate, sono espresse in mm.

Note: All dimensions are expressed in mm.

**ATTACCHI PER ELEVATORI, MIETITREBBIA
ATTACHMENTS FOR COMBINE HARVESTER, ELEVATORS**

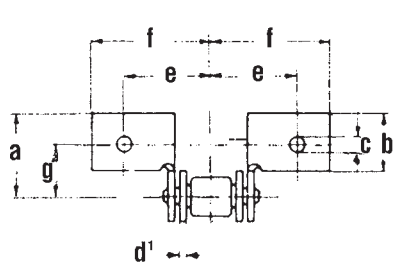

F-1 F-81

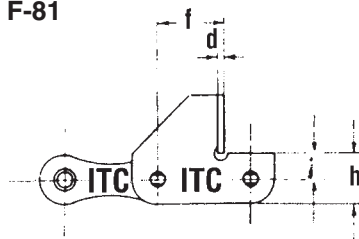

F-100**

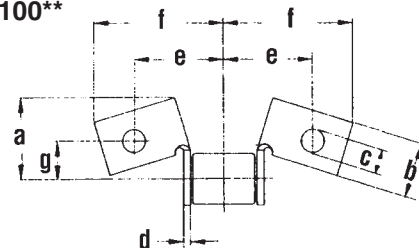

Tipo F-1 F-81 F-100 / Type F-1 F-81 F-100

PER CATENA N° FOR CHAIN N°	Tipo di attacco Type of attachment	Passo Pitch P mm	a mm	b mm	c mm	d mm	d' mm	e mm	f mm	g mm	h mm	i mm	l mm
S 45	F 1	41,40	29,0	19,0	6,5	2,5	2,5	31,0	44,6	19,0	19,0	10,0	31,9
S 51	F 1	38,10	29,0	19,0	6,5	2,5	2,5	27,2	34,9	19,0	19,0	10,0	28,7
S 52	F 1	38,10	29,0	19,0	6,5	2,5	2,5	31,0	44,6	19,0	19,0	10,0	28,7
S 55	F 1	41,40	29,0	19,0	6,5	2,5	2,5	31,0	44,6	19,0	19,0	10,0	31,9
S 62	F 1	41,91	29,0	19,0	6,5	2,5	2,5	32,0	46,1	19,0	19,0	10,0	32,4
S 55	F 81	41,4	29,0	19,0	6,5	2,5	2,5	29,0	44,6	20,0	19,0	10,0	31,9
S 55	F 100	41,4	29,0	19,0	6,5	2,5	-	31,0	44,6	19,0	-	10,0	-

** Attacco F-100 disponibile solo su maglia interna
F-100 attachment available only on inner plate.

AGRICOLTURA / AGRICULTURE

**SERIE AGRICOLA AMERICANA
EUROPEAN AGRICULTURAL SERIES (ASA)**

Nota: Tutte le dimensioni indicate, sono espresse in mm.

Note: All dimensions are expressed in mm.

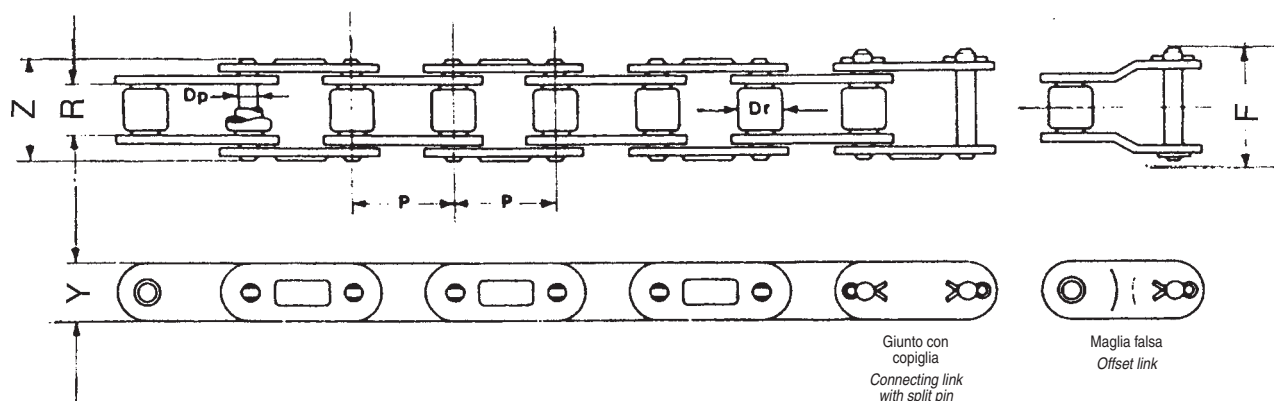

CATENE CA / CA CHAINS

		Passo Pitch P mm	Diam. rullo max. Max. roller diam. Dr mm	Largh. Int. min. Width between inner plates R mm	Diam. perno max Max. pin diam. Dp mm	Altezza piastra max Inner plate depth Y mm	Largh. perno ribad. Width over riveted pin Z mm	Ingombro catena max Max. width over bearing pins F mm	Superf. di lavoro Working surface mm ²	Carico di rottura medio Medium breaking load N	Peso netto al m Approx. weight Kg/m
CA 555	-	41,40	16,81	12,70	7,14	19,30	29,60	34,30	135	47.530	193
CA 550	-	41,40	16,66	20,00	7,14	19,30	34,90	40,40	180	37.900	1,93
CA 550 R	-	41,40	16,81	19,80	7,18	19,30	36,25	41,80	189	55.870	2,00
CA 620 •	-	42,01	17,68	25,00	7,14	20,05	45,2	48,50	234	58.200	2,34
CA 2063 H	-	38,10	11,89	12,70	5,95	19,30	29,40	34,20	114	36.100	1,65

AGRICOLTURA / AGRICULTURE

**SERIE AGRICOLA EUROPEA (ISO)
EUROPEAN AGRICULTURAL SERIES (ISO)**

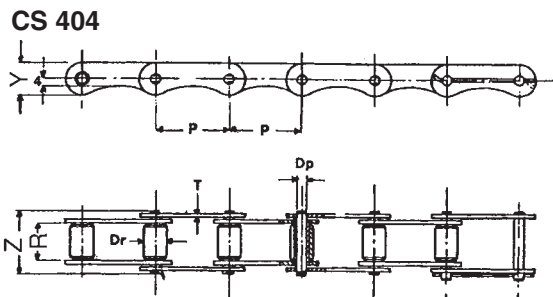
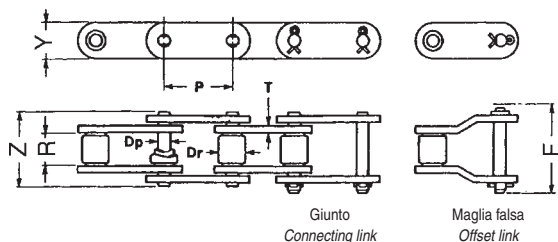

TIPO DIN STANDARD E SPECIALI / DIN TYPE - STANDARD AND SPECIALS

	ISO N°	Passo Pitch P mm	Diam. rullo max. Max. roller diam. Dr mm	Largh. Int. min. Width between inner plates R mm	Diam. perno max Max. pin diam. Dp mm	Altezza piastra max Inner plate depth Y mm	Spessore piastra max Max. thickness plate T mm	Largh. perno ribad. Width over riveted pin Z mm	Ingombro catena max Max. width over bearing pins F mm	Superf. di lavoro Working surface mm ²	Carico di rottura medio Medium breaking load N	Peso netto al m Net weight per mt Kg/m
CA 39	-	38,40	15,88	19,00	6,92	17,20	2,50	33,10	38,30	166	34.200	1,70
CA 622 •	-	38,40	21,00	19,00	6,92	17,20	2,50	33,10	38,30	166	34.200	2,00
CA 623 •	-	38,40	21,00	19,00	6,92	17,20	3,00	34,10	39,50	166	34.200	2,10
CA 624	-	38,40	15,88	19,00	8,27	20,50	3,00	34,40	44,20	207	45.600	1,90
CA 2801	-	30,00	15,88	19,00	8,27	20,50	3,00	34,40	44,20	207	59.000	2,00
CS 404	-	40,00	12,07	21,50	6,00	18,00	3,00	37,40	43,27	165	39.000	1,60

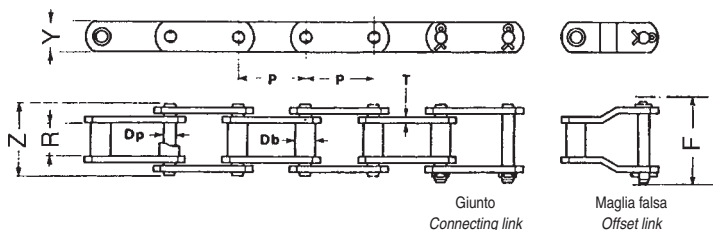

TIPO A BUSSOLE / SLEEVES TYPE

	ISO N°	Passo Pitch P mm	Diam. bussola Sleeve diam. Db mm	Largh. Int. min. Width between inner plates R mm	Diam. perno max Max. pin diam. Dp mm	Altezza piastra max Inner plate depth Y mm	Spessore piastra max Max. thickness plate T mm	Largh. perno ribad. Width over riveted pin Z mm	Ingombro catena max Max. width over bearing pins F mm	Superf. di lavoro Working surface mm ²	Carico di rottura medio Medium breaking load N	Peso netto al m Net weight per mt Kg/m
CA 395	-	38,40	10,38	19,00	6,92	17,20	2,50	33,10	38,30	166	34.200	1,50

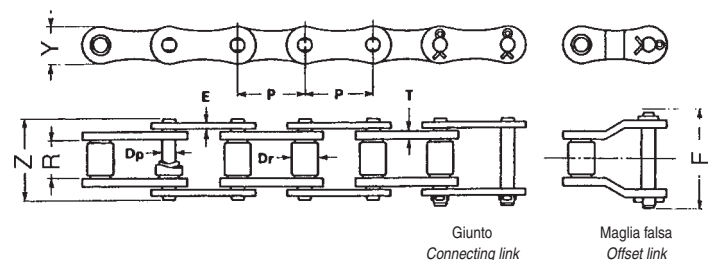

TIPO RINFORZATO / REINFORCED TYPE

	ISO N°	Passo Pitch P mm	Diam. rullo max. Max. roller diam. Dr mm	Largh. Int. min. Width between inner plates R mm	Diam. perno max Max. pin diam. Dp mm	Altezza piastra max Inner plate depth Y mm	Spessore piastra max Max. thickness plate T mm	Largh. perno ribad. Width over riveted pin Z mm	Ingombro catena max Max. width over bearing pins F mm	Superf. di lavoro Working surface mm ²	Carico di rottura medio Medium breaking load N	Peso netto al m Net weight per mt Kg/m
CA 642	-	41,40	15,88	19,00	8,27	22,20	3,00	34,40	44,20	207	56.200	1,90
CA 643	-	41,40	15,88	22,20	8,27	22,20	4,00	41,00	48,30	252	69.500	2,40
CA 644 •	-	41,40	19,05	22,20	8,27	22,20	4,00	41,00	48,30	252	69.500	2,80
CA 645	-	41,40	17,78	22,20	8,27	22,20	4,00	41,00	48,30	252	69.500	2,60

• Catena costruita solo su richiesta / Manufactured under request only

AGRICOLTURA / AGRICULTURE

**ATTACCHI SPECIALI
SPECIAL ATTACHMENTS**

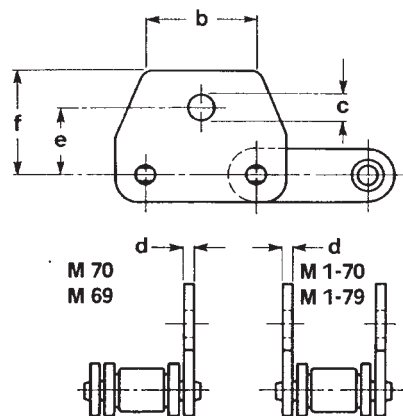
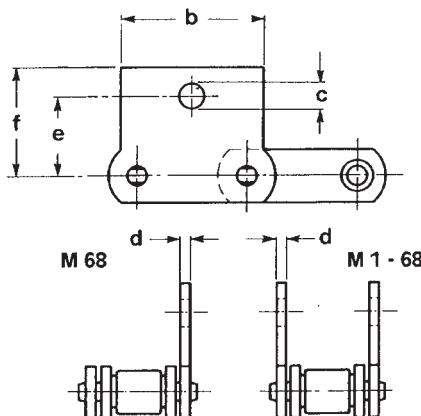
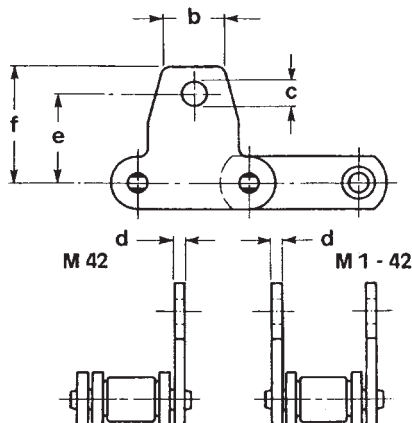

	Tipo di attacco Type of attachment	Passo Pitch			c' mm	d mm	e mm	f mm	Sovrappeso unitario approx. Approx. unitary over weight	
		P mm	b mm	c mm					attacco attachment M Kg	attacco attachment M1 Kg
CA 39	M 42 : M 1- 42	38,40	20,00	8,50	—	2,50	27,70	39,50	0,015	0,030
CA 39	M 69 : M 1- 69	38,40	40,00	10,30	—	2,50	28,00	41,60	0,048	0,096
CA 395	M 42 : M 1- 42	38,40	20,00	8,50	—	2,50	27,70	39,50	0,015	0,030
CA 395	M 69 : M 1- 69	38,40	40,00	10,30	—	2,50	28,00	41,60	0,048	0,096
CA 623	M 68 : M 1- 68	38,40	47,00	8,50	—	3,00	23,50	32,50	0,017	0,034
CA 624	M 70 : M 1- 70	38,40	40,00	10,30	—	3,00	25,00	39,60	0,053	0,106
CA 643	M103 : M 1-103	41,40	40,00	8,50	11,25	3,10	21,50	39,20	0,060	0,120

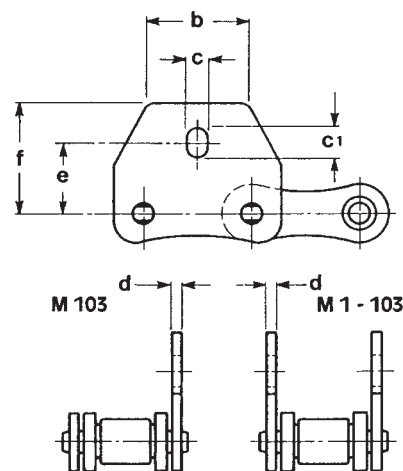

PIASTRA SPECIALE SALVAPERNO / SPECIAL PLATE PIN SAVER

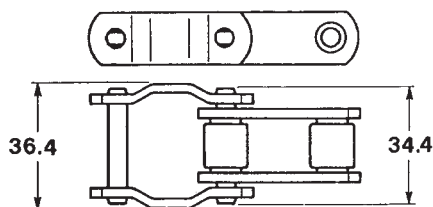

K 108
APPLICABILE SULLE CATENE
CA 600 e CA 624

K 108
TO USE WITH CA 600 AND
CA 624 CHAINS

CATENA PER RACCOGLITORE, CARRELLI AUTOCARICANTI / CHAIN FOR SELF LOADING AGRICULTURAL TRAILERS

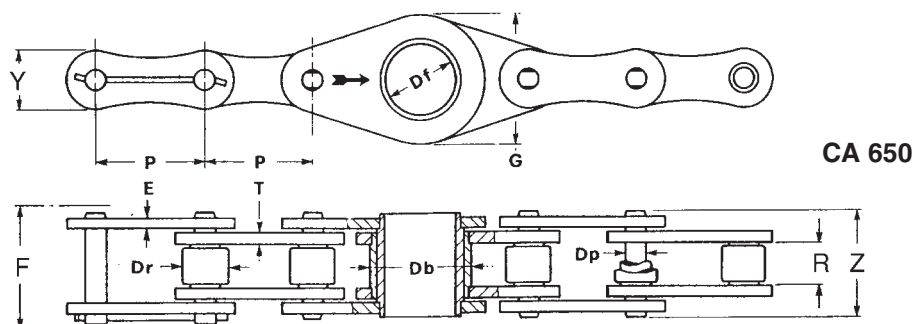

ISO N°	Passo Pitch P mm	Diam. rullo max Max. roller diam. Db mm	Largh. int. min. Width between inner plates R mm	Diam. perno max Max. pin diam. Dp mm	Diam. foro perno Diam. hole of pin Df mm	Diametro bussola Sleeve diam. Db mm	Altezza piastra libera Free plate depth G mm	Altezza piastra max Inner plate depth Y mm	Spess. piastra int. Inner plates thickness T mm	Spess. piastra est. Outer plates thickness E mm	Largh. perno ribad. Width over riveted pin Z mm	Ingombro catena max Max. width over bearing pins F mm	Superf. di lavoro Working surface mm ²	Carico di rottura medio Medium breaking load N	Peso netto al m Net weight per mt Kg/m
CA 650	50,80	19,05	19,05	9,52	35,00	48,00	63	26,70	4,00	4,00	40,20	46,80	260	97.800	3,62

AGRICOLTURA / AGRICULTURE

**CATENE A PERNI FORATI PER TRASPORTATORI AGRICOLI
HOLLOW PIN CHAINS FOR AGRICULTURAL CONVEYORS**

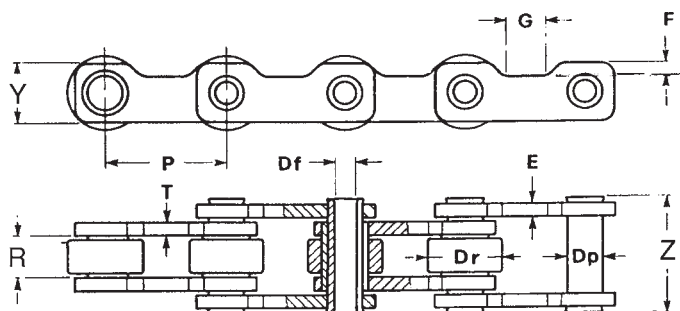

CA 732 - CA 734

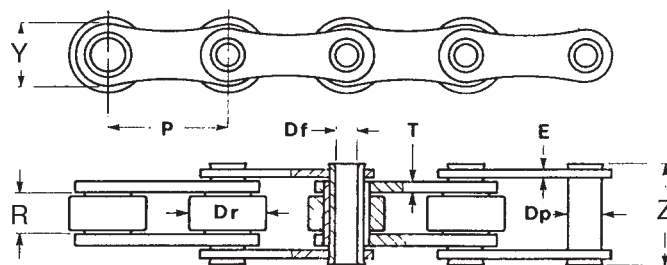

CA 733

	ISO N°	Passo	Diam. rullo max	Largh. Int. min.	Diam. perno max	Diam. foro perno	Largh. piano	Prof. piano	Altezza piastra max	Spess. piastra int.	Spess. piastra est.	Largh. perno ribad.	Superf. di lavoro	Carico di rottura medio	Peso netto al m
		Pitch	Max. roller diam.	Width between inner plates	Max. pin diam.	Diam. hole of pin	Plane depth	Plane depth	Inner plate depth	Inner plates thickness	Outer plates thickness	Width over riveted pin	Working surface	Medium breaking load	Net weight per mt
		P mm	Dr mm	R mm	Dp mm	Df mm	G mm	F mm	Y mm	T mm	E mm	Z mm	mm ²	N	Kg/m
CA 732	-	50,80	31,75	15,70	15,50	10,30	16,00	6,00	27,20	4,00	4,00	35,20	367	67.700	3,73
CA 733	-	50,80	31,75	15,70	15,50	10,30	-	-	27,20	3,70	3,25	34,00	352	53.250	2,99
CA 734	-	50,80	31,75	15,70	15,50	10,30	16,00	6,00	27,20	4,80	4,80	38,40	392	82.740	4,08



CATENE RASCHIANTI / SCRAPING CHAINS

CATENE PER TRASPORTATORI RASCHIANTI SERIE EUROPEA ISO/1977 CHAINS FOR SCRAPING CONVEYORS EUROPEAN SERIES ISO/1977

Catena N° Chain N°	P mm	L mm	D5 mm	D6 mm	H mm	S mm	g mm	F3 mm	Carico di rottura	Peso catena
									Breaking load	Weight of chain
									Kg	* Kg-m
EMR 56	100	24	15	10	30	4	20	•	5.600	2,8
EMR 56	125	24	15	10	30	4	20	•	5.600	2,6
EMR 80	100	28	18	12	35	5	25	•	8.000	4,3
EMR 80	125	28	18	12	35	5	25	•	8.000	4
EMR 80	160	28	18	12	35	5	25	•	8.000	3,7
EMR 112	100	32	21	15	40	6	35	•	11.200	6,2
EMR 112	125	32	21	15	40	6	35	•	11.200	5,7
EMR 112	160	32	21	15	40	6	35	•	11.200	5,3
EMR 160	100	37	25	18	50	7	40	•	16.000	9,7
EMR 160	125	37	25	18	50	7	40	•	16.000	8,9
EMR 160	160	37	25	18	50	7	40	•	16.000	8,2
EMR 224	125	43	30	21	60	8	44	•	22.400	13
EMR 224	160	43	30	21	60	8	44	•	22.400	12
EMR 224	200	43	30	21	60	8	44	•	22.400	11
EMR 315	160	48	36	25	70	10	50	•	31.500	18,3
EMR 315	200	48	36	25	70	10	50	•	31.500	16,7
EMR 315	250	48	36	25	70	10	50	•	31.500	15,6

Versioni alternative:

- Coppigliata da 1 o 2 lati
- Esecuzione fori su pale raschianti
- Acciaio inossidabile

- Dimensioni libere

- * Senza pale raschianti

Alternative types:

- Split pin on one side or both
- With holes on scraping shovel
- Stainless steel

- Free dimensions

- * Without scraping shovel

Ruote dentate su richiesta.

Gears available under request.

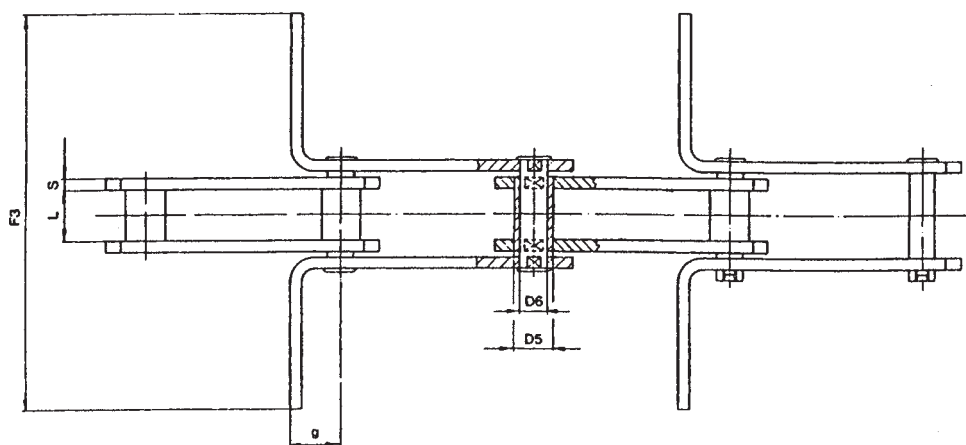
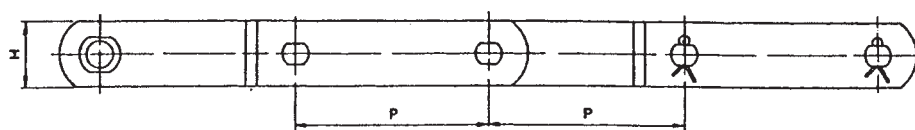



CATENE TOP LINE / TOP LINE CHAINS

RETTILINEE CON TAPPARELLE IN ACCIAIO "STRAIGHT LINE TOP" "STRAIGHT LINE TOP" WITH STEEL FLAT-TOP CHAINS

In funzione del tipo d'applicazione, le catene della linea "Straight line top" sono fornibili in materiali diversi. Per la resistenza più elevata all'usura, è preferibile la versione in Acciaio al carbonio bonificato (es. settori vetrario, ceramico e generalmente nei trasporti interni). Per particolari esigenze di resistenza all'usura, per impieghi ancor più probanti (percorsi abrasivi e velocità di scorrimento particolarmente elevate) è consigliata la versione in Acciaio carbo nitrato. Per l'industria dell'imbottigliamento invece è consigliata la versione in Acciaio inox ferritico, mentre per la massima resistenza a corrosione, è possibile fornire la versione in Acciaio inossidabile austenitico.

"Straight line top" chains can be supplied with different materials as per type of application. To obtain a higher resistance against wear the "hardened and tempered", carbon steel type should be used (ex. glass sector, tiles sector and inner transports). To even more heavy applications and to even more resistance against wear (very high sliding speeds and abrasive ways) the carbonitride steel carbon version is recommended. For bottling industry the ferritic stainless steel type should be used, whereas for maximum resistance against corrosion the austenitic stainless steel has to be mounted.

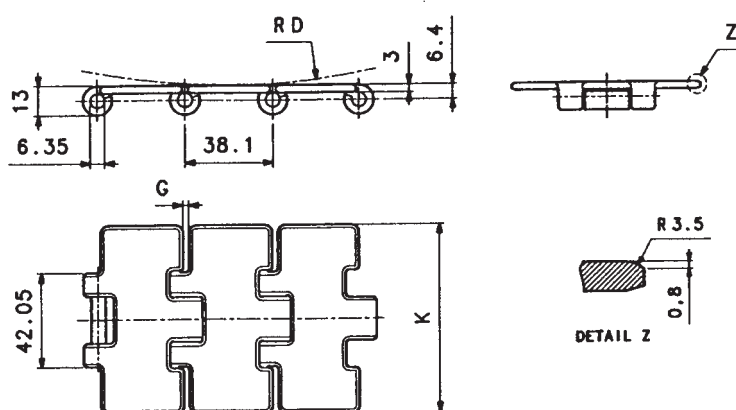

Materiale Material	Denominazione Ref.	Rif. ISO 4348 ISO Ref.	Carico rottura medio Medium breaking load Rm N	Carico snervamento medio Medium yield point Rp 0.2 N	Durezza a cuore Hardness HRC	Durezza superficiale Superficial hardness HRC	Larghezza tapparelle Flat top chain width K mm	G mm	RD mm	Peso per unità di lunghezza Weight per unit of length Kg/m
ACCIAIO AL CARBONIO BONIFICATO HARDENED AND TEMPERED CARBON STEEL	ES 815 K 2 ¹ / ₄	—	14.800	11.600	43	43	57.1	1.8	150	2.18
	ES 815 K 2 ² / ₃	—	14.800	11.600	43	43	66.7	1.8	150	2.40
	ES 815 K 3 ¹ / ₄	C13S	14.800	11.600	43	43	82.6	1.8	150	2.73
	ES 815 K 3 ¹ / ₂	C14S	14.800	11.600	43	43	88.9	1.8	150	3.00
	ES 815 K 4	C16S	14.800	11.600	43	43	101.6	1.8	150	3.20
	ES 815 K 4 ¹ / ₂	C18S	14.800	11.600	43	43	114.3	1.8	150	3.48
	ES 815 K 6	C24S	14.800	11.600	43	43	152.4	1.8	150	4.38
ACCIAIO CARBONITRURATO CARBONITRIDED STEEL	ES 815 K 7 ¹ / ₂	C30S	14.800	11.600	43	43	190.5	1.8	150	5.27
	SH 815 K 3 ¹ / ₄	C13S	11.700	9.200	40	60 *	82.6	1.8	150	2.73
	SH 815 K 4 ¹ / ₂	C18S	11.700	9.00	40	60 *	114.3	1.8	150	3.48

* Durezza 90 HR 15N equivalenti a 60 HRC / Hardness 90 HR 15N equivalent to 60 HRC

Larghezze non indicate in tabella solo su richiesta / Width not indicated above available only under request

Fornite in confezione da 80 passi (3,048 m)

Supplied with 80 pitch (3,048 m) boxes

CATENE TOP LINE / TOP LINE CHAINS

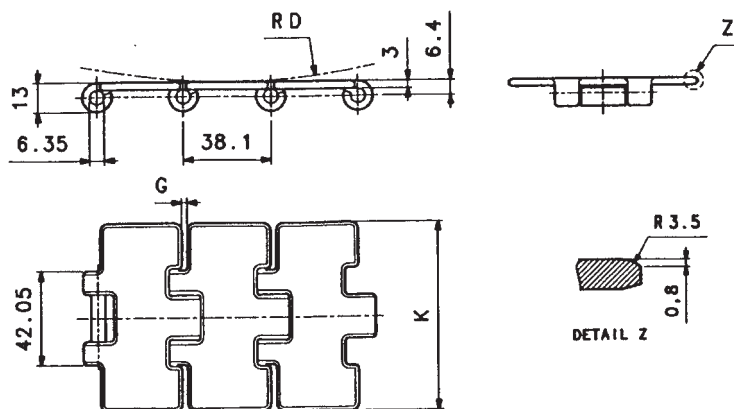
RETTILINEE CON TAPPARELLE IN ACCIAIO "STRAIGHT LINE TOP"
"STRAIGHT LINE TOP" WITH STEEL FLAT-TOP CHAINS

E815 (ACCIAIO INOSSIDABILE) / E815 (STAINLESS STEEL)

Materiale Material	Denominazione Ref.	Rif. ISO 4348 ISO Ref.	Carico rottura medio Medium breaking load Rm N	Carico snervamento medio Medium yield point Rp 0,2 N	Durezza Hardness HRC	Rugosità Roughness Ra µm	Larghezza tapparelle Flat top chains width K mm	G mm	RD mm	Peso per unità di lunghezza Weight for unit of lenght Kg/m
ACCIAIO INOSSIDABILE FERRITICO FERRITIC STAINLESS STEEL	ESS 815-4 K 3/4	C13S	7.300	5.500	20	0.6	82.6	1.8	150	2.73
	ESSM 815-4 K 3/4	-	10.000	5.500	20	0.6	82.6	2.8	75	2.70
"SPECIAL"	E 815 K 2 1/4	-	10.000	7.800	32	0.3	57.1	1.8	150	2.18
	E 815 K 2 5/8	-	10.000	7.800	32	0.3	66.7	1.8	150	2.40
	E 815 K 3 1/4	C13S	10.000	7.800	32	0.3	82.6	1.8	150	2.73
	E 815 K 3 1/2	C14S	10.000	7.800	32	0.3	88.9	1.8	150	3.00
	E 815 K 4	C15S	10.000	7.800	32	0.3	101.6	1.8	150	3.20
	E 815 K 4 1/2	C18S	10.000	7.800	32	0.3	114.3	1.8	150	3.48
	E 815 K 6	C24S	10.000	7.800	32	0.3	152.4	1.8	150	4.38
	E 815 K 7 1/2	C30S	10.000	7.800	32	0.3	190.5	1.8	150	5.27
ACCIAIO INOSSIDABILE AUSTENITICO AUSTENITIC STAINLESS STEEL	ESS 815 K 2 1/4	-	9.700	5.300	-	0.6	57.1	1.8	150	2.18
	ESS 815 K 2 5/8	-	9.700	5.300	-	0.6	66.7	1.8	150	2.40
	ESS 815 K 3 1/4	C13S	9.700	5.300	-	0.6	82.6	1.8	150	2.73
	ESS 815 K 3 1/2	C14S	9.700	5.300	-	0.6	88.9	1.8	150	3.00
	ESS 815 K 4	C15S	9.700	5.300	-	0.6	101.6	1.8	150	3.20
	ESS 815 K 4 1/2	C18S	9.700	5.300	-	0.6	114.3	1.8	150	3.48
	ESS 815 K 6	C24S	9.700	5.300	-	0.6	152.4	1.8	150	4.38
	ESS 815 K 7 1/2	C30S	9.700	5.300	-	0.6	190.5	1.8	150	5.27

- Per tutte le catene in acciaio inossidabile il carico di snervamento allo 0,2% è tale da garantire l'appartenenza al grado 1 della specifica ISO 4348 (il carico di snervamento è la caratteristica più importante ai fini della resistenza ai sovraccarichi). Larghezze non indicate in tabella solo su richiesta.

- For all stainless steel chains, the 0,2% yield point grants the first grade of ISO 4348 requirements (yield point is the most important characteristic against over-loads). Width not indicated above, available only under request.

Fornite in confezione da 80 passi (3,048 m).
Supplied with 80 pitch (3,048) boxes.

CATENE TOP LINE / TOP LINE CHAINS

RETTILINEE CON TAPPARELLE IN ACCIAIO "STRAIGHT LINE TOP"
 "STRAIGHT LINE TOP" WITH STEEL FLAT-TOP CHAINS

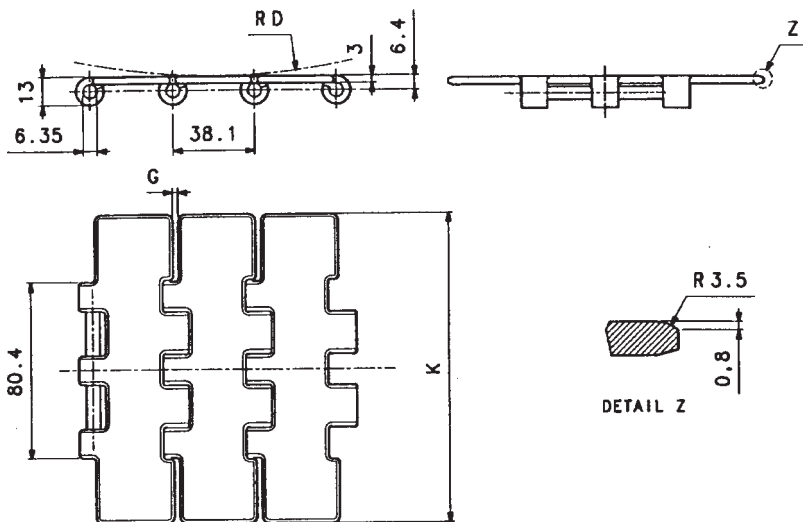

E2815 (DOPPIA CERNIERA) / E2815 (DOUBLE HINGE)

Materiale Material	Denominazione Ref.	Rif. ISO 4348 ISO Ref.	Carico rottura medio Medium breaking load Rm N	Carico snervamento medio Medium yield point Rp 0,2 N	Durezza Hardness HRC	Larghezza tapparelle Flat top chains width K mm	G mm	RD mm	Peso per unità di lunghezza Weight for unit of length Kg/m
ACCIAIO AL CARBONIO CARBON STEEL	ES 2815	K170*	28.000	17.000	43	170.5	1.8	150	5.40
	ES 2815	K 7½	C30D	28.000	17.000	43	190.5	1.8	5.90
ACCIAIO INOSSIDABILE FERRITICO FERRITIC STAINLESS STEEL	ESS 2815-4	K170	13.300	9.600	20	170.5	1.8	150	5.40
	ESS 2815-4	K 7½	C30D	13.300	9.600	20	190.5	1.8	5.90
ACCIAIO INOSSIDABILE AUSTENITICO AUSTENITIC STAINLESS STEEL	ESS 2815	K170	18.000	10.000	-	170.5	1.8	150	5.40
	ESS 2815	K 7½	C30D	18.000	10.000	-	190.5	1.8	5.90

* Su richiesta.

Larghezze non indicate in tabella solo su richiesta.

Under request.

Width not indicated above, available only under request.

Fornite in confezione da 80 passi (3,048 m)
 Supplied with 80 pitch (3,048 m) boxes

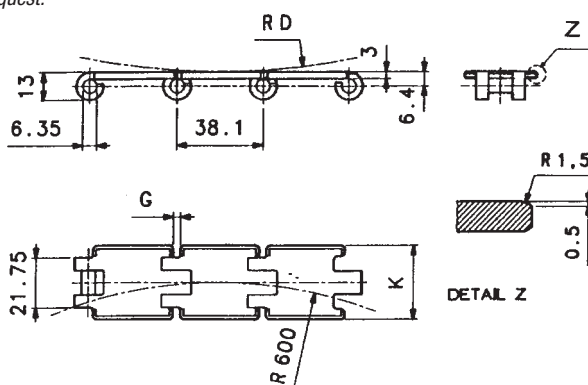

E803

Materiale Material	Denominazione Ref.	Rif. ISO 4348 ISO Ref.	Carico rottura medio Medium breaking load Rm N	Carico snervamento medio Medium yield point Rp 0,2 N	Durezza Hardness HRC	Larghezza tapparelle Flat top chains width K mm	G mm	RD mm	Peso per unità di lunghezza Weight for unit of length Kg/m
"SPECIAL"	E 803 K1¼	-	4.900	3.800	32	31.8	2.8	75	1.1

Fornite in confezione da 80 passi (3,048 m)
 Supplied with 80 pitch (3,048 m) boxes

CATENE TOP LINE / TOP LINE CHAINS

RETTILINEE CON TAPPARELLE IN ACCIAIO "STRAIGHT LINE TOP" "STRAIGHT LINE TOP" WITH STEEL FLAT-TOP CHAINS

Le catene a rulli con tapparelle in acciaio, garantiscono elevate capacità di carico e scorrevolezza. Sono particolarmente indicate dove le caratteristiche principali dell'applicazione sono carichi elevati e velocità. La versione "E844", differisce dalla "E1864" per il diverso montaggio delle tapparelle: saldate sulla E844 e fissa montata a scatto sulla E1864 e perciò sostituibile.

Roller chains with steel flat-top chains, grant great load ability and smoothness: they are particularly suitable for applications where very high rotation speeds and heavy loads must be stood. "E844" version is different from the "E1864", because of a different assembling of flat-top chains: in fact they are welded on E844 whereas they are assembled by release on 1844, which are therefore replaceable.

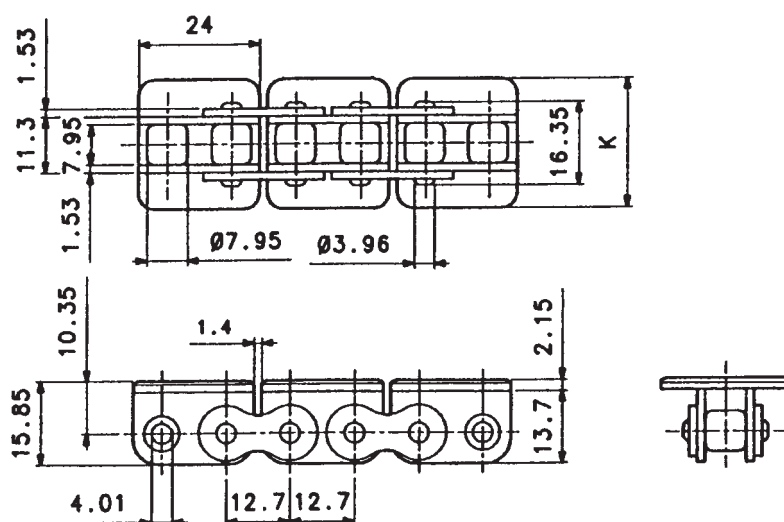

E844

Materiale catena base Standard chain material	Materiale tapparelle Flat-top chains material	Denominazione Ref.	Carico rottura medio Medium breaking load	Larghezza tapparelle Flat top chains width	Peso per unità di lunghezza Weight for unit of length
			Rm N	K mm	Kg/m
ACCIAIO AL CARBONIO CARBON STEEL	ACCIAIO AL CARBONIO CARBON STEEL	E 844 K 1	16.150	25.4	1.18
		E 844 K 1½	16.150	38.1	1.33
		E 844 K 3¼	16.150	82.6	2.00
ACCIAIO AL CARBONIO CARBON STEEL	ACCIAIO INOX STAINLESS STEEL	E A 844 K 1	16.150	25.4	1.18
		E A 844 K 1½	16.150	38.1	1.33
		E A 844 K 3¼	16.150	82.6	2.00
ACCIAIO INOX STAINLESS STEEL	ACCIAIO INOX STAINLESS STEEL	E SS 844 K 1	11.000	25.4	1.18
		E SS 844 K 1½	11.000	38.1	1.33
		E SS 844 K 3¼	11.000	82.6	2.00

Fornite in confezione da 240 passi (3,048 m).
Supplied with 240 pitch (3,048) boxes.

CATENE TOP LINE / TOP LINE CHAINS

**RETTILINEE CON TAPPARELLE IN ACCIAIO “STRAIGHT LINE TOP”
“STRAIGHT LINE TOP” WITH STEEL FLAT-TOP CHAINS**

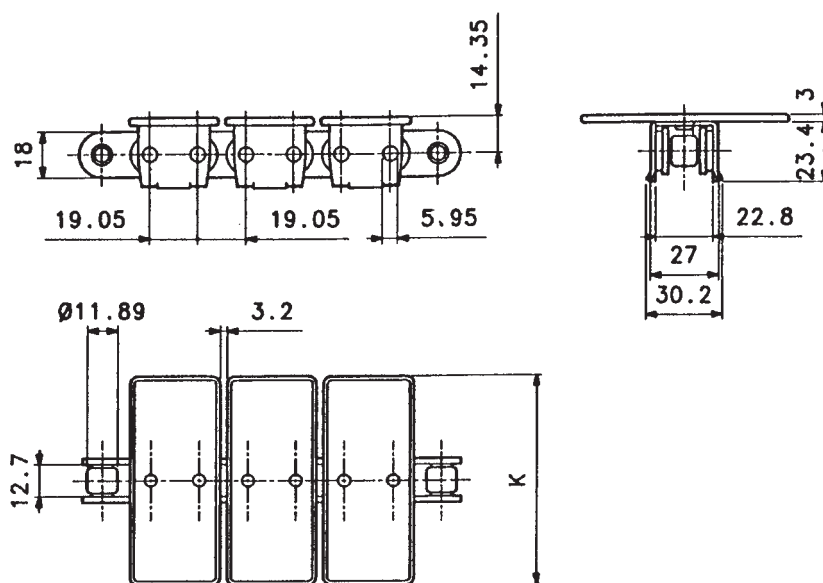

E1864

Materiale catena base Standard chain material	Materiale tapparelle Flat-top chains material	Denominazione Ref.	Carico rottura medio Medium breaking load	Larghezza tapparelle Flat top chains width	Peso per unità di lunghezza Weight for unit of length
			Rm N	K mm	Kg/m
ACCIAIO AL CARBONIO CARBON STEEL	ACCIAIO AL CARBONIO CARBON STEEL	E 1864 K 3 ¹ / ₄	35.000	82.6	4.20
		E 1864 K 4 ¹ / ₂	35.000	114.3	4.80
		E 1864 K 6	35.000	152.4	5.70
		E 1864 K 7 ¹ / ₂	35.000	190.5	6.40
ACCIAIO AL CARBONIO CARBON STEEL	ACCIAIO INOX STAINLESS STEEL	E A 1864 K 3 ¹ / ₄	35.000	82.6	4.20
		E A 1864 K 4 ¹ / ₂	35.000	114.3	4.80
		E A 1864 K 6	35.000	152.4	5.70
		E A 1864 K 7 ¹ / ₂	35.000	190.5	6.40
ACCIAIO INOX STAINLESS STEEL	ACCIAIO INOX STAINLESS STEEL	E SS 1864 K 3 ¹ / ₄	25.000	82.6	4.20
		E SS 1864 K 4 ¹ / ₂	25.000	114.3	4.80
		E SS 1864 K 6	25.000	152.4	5.70
		E SS 1864 K 7 ¹ / ₂	25.000	190.5	6.40

Fornite in confezione da 160 passi (3,048 m).
Supplied with 160 pitch (3,048) boxes.

CATENE TOP LINE / TOP LINE CHAINS

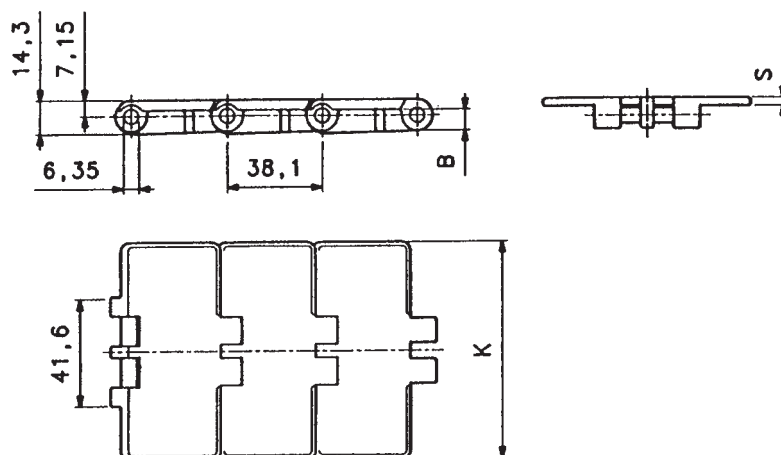
RETTILINEE CON TAPPARELLE IN RESINA "STRAIGHT LINE TOP"
"STRAIGHT LINE TOP" WITH RESIN FLAT-TOP CHAINS

E820

Materiale Material	Denominazione Ref.	Carico rottura medio Medium breaking load	Larghezza tapparelle Width of flat-top chain	S mm	B mm	Peso per unità di lunghezza Weight for unit of length
		Rm N	K mm			Kg/m
RESINA ACETALICA GRIGIA GRAY ACETALIC RESIN	E 820 K 3 ¹ / ₄	4.600	82.6	4.0	9.5	0.84
	E 820 K 4	4.600	101.6	4.0	9.5	0.95
	E 820 K 4 ¹ / ₂	4.600	114.3	4.0	9.5	1.02
	E 820 K 6	4.600	152.4	4.0	9.5	1.25
	E 820 K 7 ¹ / ₂	4.600	190.5	4.0	9.5	1.47
RESINA ACETALICA ELF MARRONE CHIARO LIGHT BROWN ELF ACETALIC RESIN	ELF 820 K 3 ¹ / ₄	4.600	82.6	4.0	9.5	0.84
	ELF 820 K 4	4.600	101.6	4.0	9.5	0.95
	ELF 820 K 4 ¹ / ₂	4.600	114.3	4.0	9.5	1.02
	ELF 820 K 6	4.600	152.4	4.0	9.5	1.25
	ELF 820 K 7 ¹ / ₂	4.600	190.5	4.0	9.5	1.47

E831 (SPESSORE PIASTRA MAGGIORATO) / E831 (INCREASED THICKNESS OF PLATE)

Materiale Material	Denominazione Ref.	Carico rottura medio Medium breaking load	Larghezza tapparelle Width of flat-top chain	S mm	B mm	Peso per unità di lunghezza Weight for unit of length
		Rm N	K mm			Kg/m
RESINA ACETALICA ELF MARRONE CHIARO LIGHT BROWN ELF ACETALIC RESIN	ELF 831 K 3 ¹ / ₄	4.600	82.6	4.8	8.7	1.00
	ELF 831 K 4 ¹ / ₂	4.600	114.3	4.8	8.7	1.24
	ELF 831 K 7 ¹ / ₂	4.600	190.5	4.8	8.7	1.76

Fornite in confezione da 80 passi (3,048 m).
Supplied with 80 pitch (3,048 m) boxes.

CATENE TOP LINE / TOP LINE CHAINS

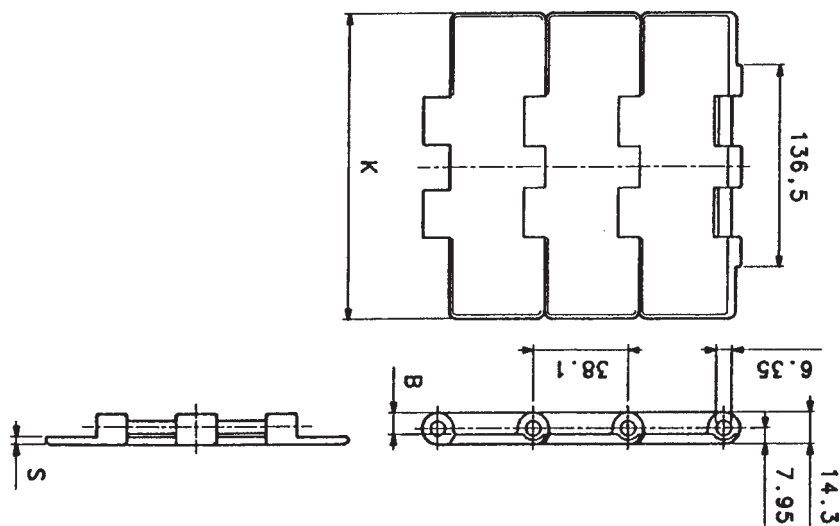
RETTILINEE CON TAPPARELLE IN RESINA "STRAIGHT LINE TOP"
"STRAIGHT LINE TOP" WITH RESIN FLAT-TOP CHAINS

E821

Materiale Material	Denominazione Ref.	Carico rottura medio Medium breaking load	Larghezza tapparelle Width of flat-top chain	S mm	B mm	Peso per unità di lunghezza Weight for unit of length
		Rm N	K mm			Kg/m
RESINA ACETALICA GRIGIA GRAY ACETALIC RESIN	E 821 K 7½	8.500	190.5	4.8	9.5	2.46
	E 821 K 10	8.500	254.0	4.8	9.5	2.98
	E 821 K 12	8.500	304.8	4.8	9.5	3.34
RESINA ACETALICA ELF MARRONE CHIARO LIGHT BROWN ELF ACETALIC RESIN	ELF 821 K 7½	8.500	190.5	4.8	9.5	2.46
	ELF 821 K 10	8.500	254.0	4.8	9.5	2.98
	ELF 821 K 12	8.500	304.8	4.8	9.5	3.34

Fornite in confezione da 80 passi (3,048 m).
Supplied with 80 pitch (3,048 m) boxes.

CATENE TOP LINE / TOP LINE CHAINS

**RETTILINEE CON TAPPARELLE IN RESINA "STRAIGHT LINE TOP"
"STRAIGHT LINE TOP" WITH RESIN FLAT-TOP CHAINS**

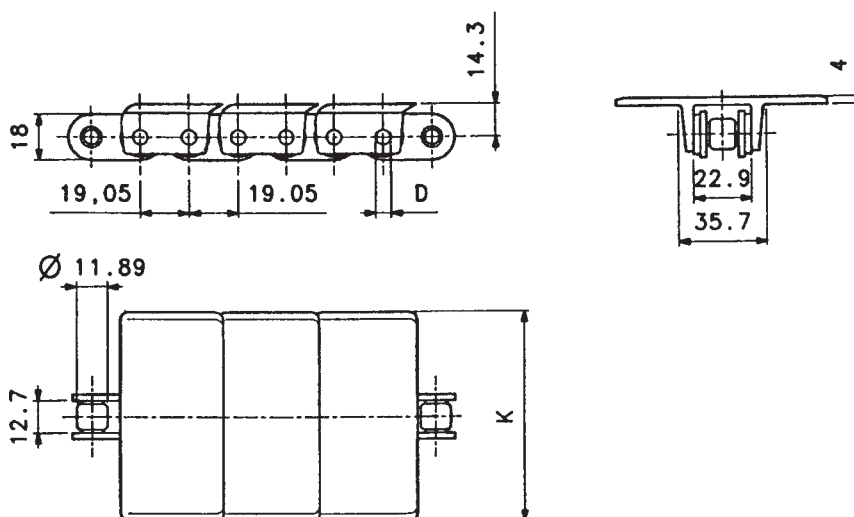

E863

Materiale catena base Material for standard chain	Denominazione Ref.				Carico rottura medio Medium breaking load Rm N	Larghezza tapparelle Width of flat-top chain K mm	Diametro perno Pin diam. D mm	Peso per unità di lunghezza Weight for unit of length Kg/m
	Resina acetilica grigia Grey acetalic resin	Resina acetilica ELF marrone chiaro Light brown ELF acetalic resin						
ACCIAIO AL CARBONIO CARBON STEEL	E 863	K 3 1/4	ELF 863	K 3 1/4	35.000	82.6	5.94	2.10
	E 863	K 4 1/2	ELF 863	K 4 1/2	35.000	114.3	5.94	2.33
	E 863	K 6	ELF 863	K 6	35.000	152.4	5.94	2.53
	E 863	K 7 1/2	ELF 863	K 7 1/2	35.000	190.5	5.94	2.68
ACCIAIO INOX STAINLESS STEEL	E 863 SS	K 3 1/4	ELF 863 SS	K 3 1/4	25.000	82.6	5.94	2.10
	E 863 SS	K 4 1/2	ELF 863 SS	K 4 1/2	25.000	114.3	5.94	2.33
	E 863 SS	K 6	ELF 863 SS	K 6	25.000	152.4	5.94	2.53
	E 863 SS	K 7 1/2	ELF 863 SS	K 7 1/2	25.000	190.5	5.94	2.68

Fornite in confezione da 160 passi (3,048 m).
Supplied with 160 pitch (3,048 m) boxes.

E963 (CATENA BASE SIDE-BOW) / E963 (SIDE BOW CHAIN)

Materiale catena base Material for standard chain	Denominazione Ref.				Carico rottura medio Medium breaking load Rm N	Larghezza tapparelle Width of flat-top chain K mm	Diametro perno Pin diam. D mm	Peso per unità di lunghezza Weight for unit of length Kg/m
	Resina acetilica grigia Grey acetalic resin	Resina acetilica ELF marrone chiaro Light brown ELF acetalic resin						
ACCIAIO AL CARBONIO CARBON STEEL	E 963	K 3 1/4	ELF 963	K 3 1/4	25.200	82.6	5.08	2.02
	E 963	K 4 1/2	ELF 963	K 4 1/2	25.200	114.3	5.08	2.25
	E 963	K 6	ELF 963	K 6	25.200	152.4	5.08	2.45
	E 963	K 7 1/2	ELF 963	K 7 1/2	25.200	190.5	5.08	2.60
ACCIAIO INOX STAINLESS STEEL	E 963 SS	K 3 1/4	ELF 963 SS	K 3 1/4	18.200	82.6	5.08	2.02
	E 963 SS	K 4 1/2	ELF 963 SS	K 4 1/2	18.200	114.3	5.08	2.25
	E 963 SS	K 6	ELF 963 SS	K 6	18.200	152.4	5.08	2.45
	E 963 SS	K 7 1/2	ELF 963 SS	K 7 1/2	18.200	190.5	5.08	2.60

Fornite in confezione da 160 passi (3,048 m).
Supplied with 160 pitch (3,048 m) boxes.

CATENE TOP LINE / TOP LINE CHAINS

**CURVILINEE CON TAPPARELLE IN ACCIAIO “CURVE TOP”
“CURVE TOP” WITH STEEL FLAT-TOP CHAINS**

La proverbiale duttilità delle catene in acciaio della linea “CURVE TOP” per percorsi curvilinei, garantisce la massima funzionabilità, anche nelle applicazioni meno propizie, risolvendo ampliamenti, problemi d’ingombro e collocazione all’interno di vari reparti produttivi.

Anche in questo caso, variegata è la possibilità di utilizzare diversi tipi di materiale, la cui scelta è, ovviamente, finalizzata alle varie tipologie d’applicazione. Qui di seguito evidenziamo le varie opportunità della gamma “ITC-CURVE TOP”.

“Curve top” steel chains are specially suitable for curvilinear ways and for particular applications where encumbrance and placing problems are present.

Once again there is a possibility of choosing different types of material: this is obviously determined by application field.

Here we enumerate the type of “ITC CURVE TOP”.

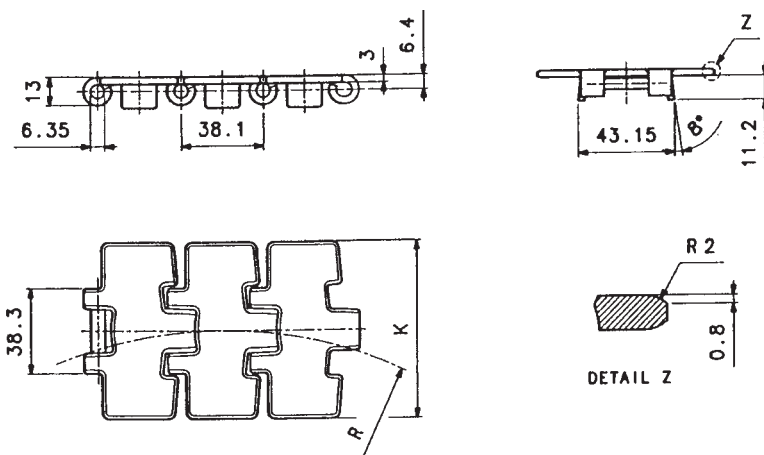

E981

Materiale Material	Denominazione Ref.	Carico rottura medio Medium breaking load	Carico snervamento medio Medium yield point	Durezza Hardness	Larghezza tapparelle Width of flat-top chain	Raggio curvatura laterale Side flex radius	Peso per unità di lunghezza Weight for unity of length
		Rm N	Rp 0,2 N	HRC	K mm	R mm	Kg/m
“SPECIAL”	E 981 K 3¼	9.120	7.600	32	82.6	457.2	3.0
	E 981 K 4½	9.120	7.600	32	114.3	609.6	3.7
	E 981 K 7½	9.120	7.600	32	190.5	609.6	5.5

Fornite in confezione da 80 passi (3,048 m).
Supplied with 80 pitch (3,048 m) boxes.

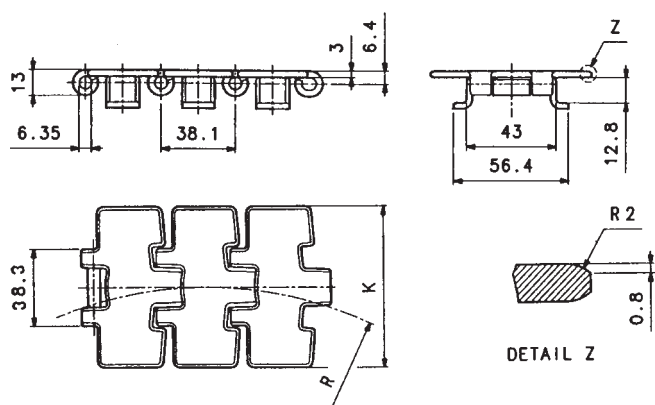

E981 T

Materiale Material	Denominazione Ref.	Carico rottura medio Medium breaking load	Carico snervamento medio Medium yield point	Durezza Hardness	Larghezza tapparelle Width of flat-top chain	Raggio curvatura laterale Side flex radius	Peso per unità di lunghezza Weight for unity of length
		Rm N	Rp 0,2 N	HRC	K mm	R mm	Kg/m
“SPECIAL”	E 981 T K 3¼	9.120	7.600	32	82.6	457.2	3.2
	E 981 T K 4½	9.120	7.600	32	114.3	609.6	3.9
	E 981 T K 7½	9.120	7.600	32	190.5	609.6	5.7

Fornite in confezione da 80 passi (3,048 m).
Supplied with 80 pitch (3,048 m) boxes.

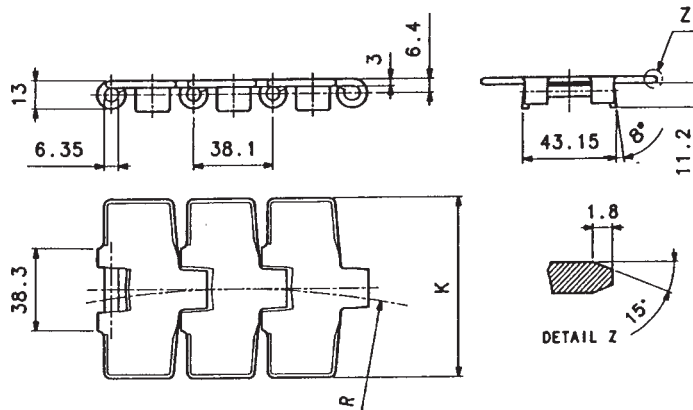

CATENE TOP LINE / TOP LINE CHAINS

CURVILINEE CON TAPPARELLE IN ACCIAIO "CURVE TOP"
"CURVE TOP" WITH STEEL FLAT-TOP CHAINS

E881

Materiale Material	Denominazione Ref.	Carico rottura medio Medium breaking load	Carico snervamento medio Medium yield point	Durezza Hardness	Larghezza tapparelle Width of flat-top chain	Raggio curvatura laterale Side flex radius	Peso per unità di lunghezza Weight for unity of length
		Rm N	Rp 0,2 N	HRC	K mm	R mm	Kg/m
ACCIAIO AL CARBONIO CARBON STEEL	ES 881 K 3 ¹ / ₄	13.900	11.000	43	82.6	457.2	3.0
	ES 881 K 4 ¹ / ₂	13.900	11.000	43	114.3	609.6	3.7
	ES 881 K 7 ¹ / ₂	13.900	11.000	43	190.5	609.6	5.5
ACCIAIO INOX AUSTENITICO AUSTENITIC STAINLESS STEEL	ESS 881 K 3 ¹ / ₄	8.800	5.300	–	82.6	457.2	3.0
	ESS 881 K 4 ¹ / ₂	8.800	5.300	–	114.3	609.6	3.7
	ESS 881 K 7 ¹ / ₂	8.800	5.300	–	190.5	609.6	5.5

Fornite in confezione da 80 passi (3,048 m).
Supplied with 80 pitch (3,048 m) boxes.

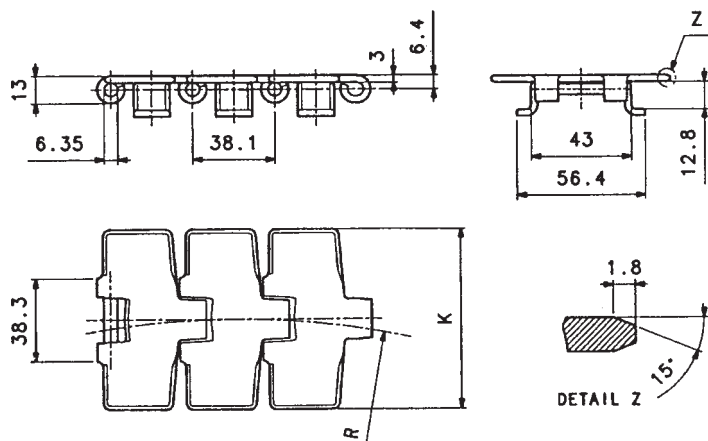

E881 T

Materiale Material	Denominazione Ref.	Carico rottura medio Medium breaking load	Carico snervamento medio Medium yield point	Durezza Hardness	Larghezza tapparelle Width of flat-top chain	Raggio curvatura laterale Side flex radius	Peso per unità di lunghezza Weight for unity of length
		Rm N	Rp 0,2 N	HRC	K mm	R mm	Kg/m
ACCIAIO AL CARBONIO CARBON STEEL	ES 881T K 3 ¹ / ₄	13.900	11.000	43	82.6	457.2	3.2
	ES 881T K 4 ¹ / ₂	13.900	11.000	43	114.3	609.6	3.9
	ES 881T K 7 ¹ / ₂	13.900	11.000	43	190.5	609.6	5.7
ACCIAIO INOX AUSTENITICO AUSTENITIC STAINLESS STEEL	ESS 881T K 3 ¹ / ₄	8.800	5.300	–	82.6	457.2	3.2
	ESS 881T K 4 ¹ / ₂	8.800	5.300	–	114.3	609.6	3.9
	ESS 881T K 7 ¹ / ₂	8.800	5.300	–	190.5	609.6	5.7

Fornite in confezione da 80 passi (3,048 m).
Supplied with 80 pitch (3,048 m) boxes.

CATENE TOP LINE / TOP LINE CHAINS

CURVILINEE CON TAPPARELLE MAGNETICHE IN ACCIAIO
“CURVE TOP”

“CURVE TOP” WITH MAGNETIC STEEL FLAT-TOP CHAINS

Le catene della serie 981 MGN, costruite in materiale speciale, sono particolarmente indicate per essere utilizzate nei trasportatori curvilinei, laddove sono richiesti avvolgimenti ed ancoraggi magnetici.

Consentono, fra l'altro, d'essere sollevate dalla guida di scorrimento, per l'esecuzione della pulizia, o per semplici esplorazioni, senza doverne eseguire lo smontaggio.

Chains of 981 MGN, series are made of special materials and particularly suitable for winding and magnetic attachments. They can be lifted from their guide to be cleaned or when an exploration without dismounting is necessary.

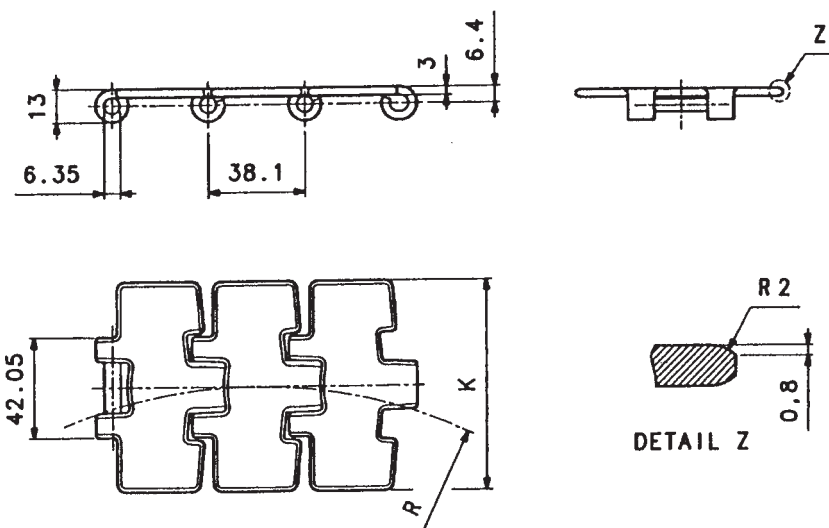

E981 M

Materiale Material	Denominazione Ref.	Carico rottura medio Medium breaking load	Carico snervamento medio Medium yield point	Durezza Hardness	Larghezza tapparelle Width of flat-top chain	Raggio curvatura laterale Side flex radius	Peso per unità di lunghezza Weight for unity of length
		Rm N	Rp 0,2 N	HRC	K mm	R mm	Kg/m
"SPECIAL"	981 M K 3 $\frac{1}{4}$	10.100	7.890	32	82.6	457	2.5
	981 M K 4 $\frac{1}{2}$	10.100	7.890	32	114.3	457	3.2
	981 M K 7 $\frac{1}{2}$	10.100	7.890	32	190.5	457	5.0

Fornite in confezione da 80 passi (3,048 m).
Supplied with 80 pitch (3,048 m) boxes.

CATENE TOP LINE / TOP LINE CHAINS

**CURVILINEE CON TAPPARELLE IN RESINA "CURVE TOP"
"CURVE TOP" WITH RESIN FLAT-TOP CHAINS**

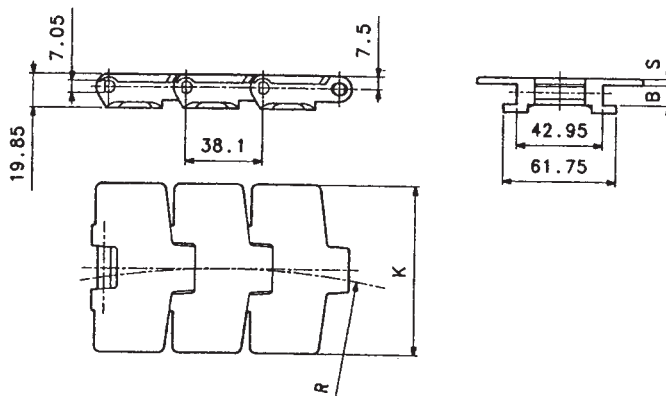

E880 T

Materiale Material	Denominazione Ref.	Carico rottura medio Medium breaking load	Larghezza tapparelle Width of flat top chains	S mm	B mm	Raggio curvatura laterale Side flex radius	Peso per unità di lunghezza Weight for unity of length
		Rm N	K mm			R mm	Kg/m
RESINA ACETALICA ELF MARRONE CHIARO ELF LIGHT BROWN ACETATE RESIN	ELF 880 T K 3¼	6.500	82.6	4.0	11.8	457.2	0.91
	ELF 880 T K 4½	6.500	114.3	4.0	11.8	609.6	1.09

Tutti i perni sono in acciaio inox austenitico
All pins are in austenitic stainless steel

Fornite in confezione da 80 passi (3,048 m).
Supplied with 80 pitch (3,048 m) boxes.

E879 T (SPESSORE PIASTRA MAGGIORATO) / E879 T (OVERSIZE PLATE'S THICKNESS)

Materiale Material	Denominazione Ref.	Carico rottura medio Medium breaking load	Larghezza tapparelle Width of flat top chains	S mm	B mm	Raggio curvatura laterale Side flex radius	Peso per unità di lunghezza Weight for unity of length
		Rm N	K mm			R mm	Kg/m
RESINA ACETALICA ELF MARRONE CHIARO ELF LIGHT BROWN ACETATE RESIN	ELF 879 T K 3¼	6.500	82.6	4.8	11.0	457.2	0.98
	ELF 879 T K 4½	6.500	114.3	4.8	11.0	609.6	1.14

Tutti i perni sono in acciaio inox austenitico
All pins are in austenitic stainless steel

Fornite in confezione da 80 passi (3,048 m).
Supplied with 80 pitch (3,048 m) boxes.

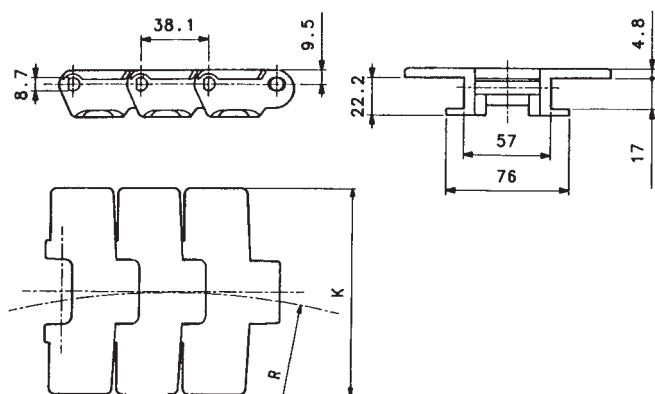

882 T (CATENA RINFORZATA) / 882 T (REINFORCED CHAIN)

Materiale Material	Denominazione Ref.	Carico rottura medio Medium breaking load	Larghezza tapparelle Width of flat top chains	Raggio curvatura laterale Side flex radius	Peso per unità di lunghezza Weight for unity of length
		Rm N	K mm		R mm
RESINA ACETALICA ELF MARRONE CHIARO ELF LIGHT BROWN ACETATE RESIN	ELF 882T K 4¼	11.550	114.3	609.6	1.98
	ELF 882T K 7½	11.550	190.5	609.6	2.43
	ELF 882T K 10	11.550	254.0	609.6	2.87
	ELF 882T K 12	11.550	304.8	609.6	3.41

Tutti i perni sono in acciaio inox austenitico
All pins are in austenitic stainless steel

Fornite in confezione da 80 passi (3,048 m).
Supplied with 80 pitch (3,048 m) boxes.

CATENE TOP LINE / TOP LINE CHAINS

CURVILINEE CARDANICHE IN RESINA "CURVE TOP" "CURVE TOP" CARDANIC RESIN CHAINS

Le caratteristiche più evidenti delle catene cardaniche "TOP LINE", sono la flessibilità, e la multidirezionalità. Concepite per curvare sia sul piano verticale che in quello orizzontale, permettono una elevata varietà di configurazioni.

La compattezza del raggio di curvatura, consente di progettare trasportatori particolarmente compatti, permettendo altresì, la costruzione di rami particolarmente tortuosi e ricchi di curve in serie, diminuendone al tempo stesso l'attrito.

"TOP LINE" cardanic chains have as their most important characteristic the flexibility and multi-direction. Especially studied for bending both on vertical and horizontal surface, they enable a great variety of configurations the compactness of sidelfax radius, enables the creation of very close conveyors.

Thanks to this, friction is reduced by many curves and winding ways.

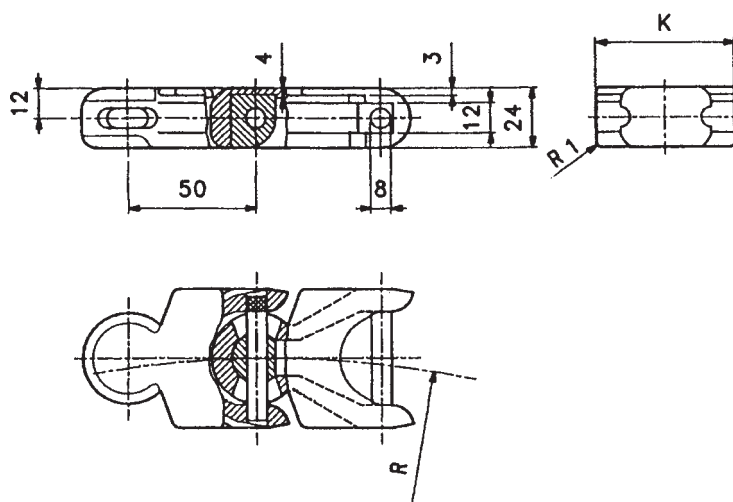

E1700

Materiale perno Pin material	Materiale maglia Plate material	Denominazione Ref.	Carico rottura medio Medium breaking load	Larghezza tapparelle Width of flat top chain	Raggio curvatura laterale Side flex radius	Peso per unità di lunghezza Weight for unit of lenght
			Rm N	K mm	R mm	Kg/m
ACCIAIO ZINCATO / ACCIAIO INOX ZINC PLATED / STAINLESS STEEL	RESINA ACETALICA BIANCA WHITE ACETALIC RESIN	EB 1700	10.300	55.0	140.0	1.27
		EC 1700	10.300	55.0	140.0	1.27
ACCIAIO ZINCATO / ACCIAIO INOX ZINC PLATED / STAINLESS STEEL	RESINA ACETALICA ELF MARRONE CHIARO ELF LIGHT BROWN ACETALIC RESIN	ELF E 1700	8.700	55.0	140.0	1.27
		ELF EA 1700	8.700	55.0	140.0	1.27

CATENE TOP LINE / TOP LINE CHAINS

**CURVILINEE CON TAPPARELLE IN RESINA "CURVE TOP"
"CURVE TOP" WITH RESIN FLAT-TOP CHAINS**

Con la scorrevolezza e planarità delle tapparelle in resina "TOP LINE", è possibile la progettazione di trasportatori con lunghi sviluppi e velocità periferiche, maggiori rispetto a quelli utilizzando normali catene a semplici tapparelle cernierate.

Thanks to the smoothness and flatness of "TOP LINE" resin flat-top chains, it is possible to project conveyors with longer dimensions and higher peripheral speeds, than normal flat-top chains.

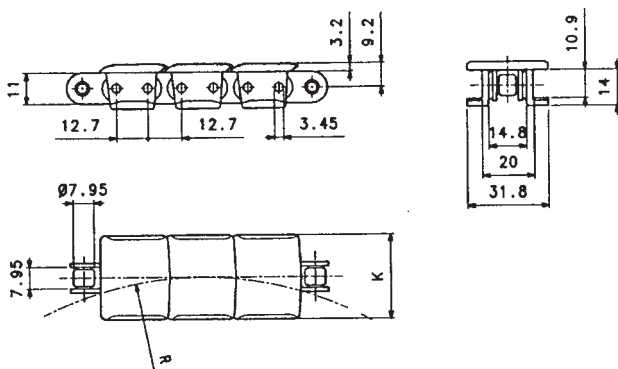

E1843 T

Materiale catena base Standard chain material	Denominazione Ref.		Carico rottura medio Medium breaking load Rm N	Larghezza tapparelle Width of flat-top chains K mm	Raggio curvatura laterale Side flex radius R mm	Peso per unità di lunghezza Weight for unit of length Kg/m
	Resina acetilica ELF speciale marrone chiaro Special ELF acetalic resin light brown					
ACCIAIO AL CARBONIO CARBON STEEL	ELF 1843 T	K1 1/4	10.000	31.8	355.6	0.75
ACCIAIO INOX STAINLESS STEEL	ELF 1843 T SS	K1 1/4	7.200	31.8	355.6	0.75

Fornite in confezione da 240 passi (3,048 m).
Supplied with 240 pitch (3,048 m).

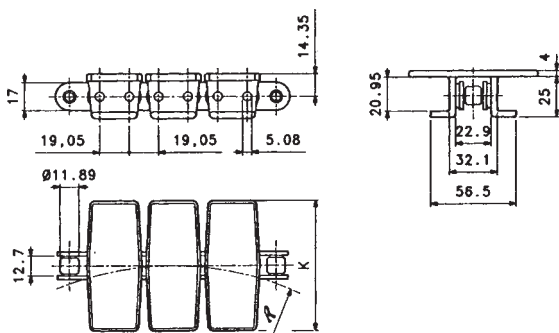

E1873 T

Materiale catena base Standard chain material	Denominazione Ref.				Carico rottura medio Medium breaking load Rm N	Larghezza tapparelle Width of flat-top chains K mm	Raggio curvatura laterale Side flex radius R mm	Peso per unità di lunghezza Weight for unit of length Kg/m
	Resina acetilica grigia Grey acetalic resin		Resina acetilica marrone chiaro Light brown acetalic resin					
ACCIAIO AL CARBONIO CARBON STEEL	E 1873 T	K 3 1/4	ELF 1873 T	K 3 1/4	25.500	82.6	355.6	2.10
	E 1873 T	K 4 1/2	ELF 1873 T	K 4 1/2	25.500	114.3	355.6	2.26
	E 1873 T	K 6	ELF 1873 T	K 6	25.500	152.4	457.2	2.41
	E 1873 T	K 7 1/2	ELF 1873 T	K 7 1/2	25.500	190.5	457.2	2.56
	E 1873 T	K 10	ELF 1873 T	K 10	25.500	254.0	457.2	2.78
	E 1873 T	K 12	ELF 1873 T	K 12	25.500	304.8	609.6	3.00
ACCIAIO INOX STAINLESS STEEL	E 1873 T SS	K 3 1/4	ELF 1873 T SS	K 3 1/4	18.200	82.6	355.6	2.10
	E 1873 T SS	K 4 1/2	ELF 1873 T SS	K 4 1/2	18.200	114.3	355.6	2.26
	E 1873 T SS	K 6	ELF 1873 T SS	K 6	18.200	152.4	457.2	2.41
	E 1873 T SS	K 7 1/2	ELF 1873 T SS	K 7 1/2	18.200	190.5	457.2	2.56
	E 1873 T SS	K 10	ELF 1873 T SS	K 10	18.200	254.0	457.2	2.78
	E 1873 T SS	K 12	ELF 1873 T SS	K 12	18.200	304.8	609.6	3.00

Fornite in confezione da 160 passi (3,048 m).
Supplied with 160 pitch (3,048 m) boxes.

CATENE TOP LINE / TOP LINE CHAINS

CURVILINEE CON TAPPARELLE IN ACCIAIO “CURVE TOP” “CURVE TOP” WITH STEEL FLAT-TOP CHAINS

Le catene a rulli con tapparelle ad elevata capacità di carico e scorrevolezza, garantiscono particolare affidamento anche per la continuità del piano di trasporto. Particolarmente indicate per velocità e carichi elevati, adottano un particolare cavallotto, con sagomatura specifica per facilitare lo scorrimento con assenza d'impuntamenti.

Roller chains supplied with flat-top chains with high loading and smoothnes capacity, are suitable for the continuity of transport plane.

Particularly indicated for high speeds and heavy loads, they are supplied with a special bent-attachment, having a specific shaping to facilitate sliding without lockings.

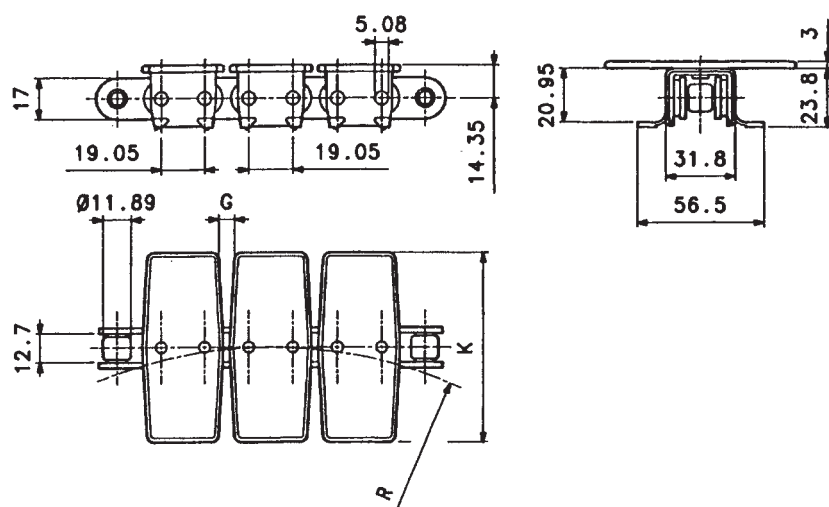

E1874 T

Materiale catena base Standard chain material	Materiale tapparelle Flat-top chains material	Denominazione Ref.	Carico rottura medio Medium breaking load Rm N	Larghezza tapparelle Width of flat-top chains K mm	G mm	Raggio curvatura laterale Sideflex radius R mm	Peso per unità di lunghezza Weight for unit of lenght Kg/m
ACCIAIO AL CARBONIO CARBON STEEL	ACCIAIO AL CARBONIO CARBON STEEL	E 1874 T K 3 ¹ / ₄	25.000	82.6	–	355.6	4.2
		E 1874 T K 4 ¹ / ₂	25.000	114.3	8.2	355.6	4.8
		E 1874 T K 6	25.000	152.4	–	457.2	5.7
		E 1874 T K 7 ¹ / ₂	25.000	190.5	–	609.6	6.4
ACCIAIO AL CARBONIO CARBON STEEL	ACCIAIO INOX STAINLESS STEEL	E A 1874 T K 3 ¹ / ₄	25.000	82.6	–	355.6	4.2
		E A 1874 T K 4 ¹ / ₂	25.000	114.3	–	355.6	4.8
		E A 1874 T K 6	25.000	152.4	8.2	457.2	5.7
		E A 1874 T K 7 ¹ / ₂	25.000	190.5	–	609.6	6.4
ACCIAIO INOX STAINLESS STEEL	ACCIAIO INOX STAINLESS STEEL	E SS 1874 T K 3 ¹ / ₄	18.000	82.6	–	355.6	4.2
		E SS 1874 T K 4 ¹ / ₂	18.000	114.3	8.2	355.6	4.8
		E SS 1874 T K 6	18.000	152.4	–	457.2	5.7
		E SS 1874 T K 7 ¹ / ₂	18.000	190.5	–	609.6	6.4

Fornite in confezione da 160 passi (3,048 m).
Supplied with 160 pitch (3,048 m) boxes.

ACCESSORI / ACCESSORIES**SMONTACATENE
CHAIN BREAKERS****TIPO N° 1**

PER CATENE DA 3/8 A 3/4
CHAIN PITCH 3/8 TO 3/4

**TIPO N° 2**

PER CATENE DA 3/4 A 1"1/4
CHAIN PITCH 3/4 TO 1"1/4





©Copyright **ITC**®

È vietata la riproduzione anche parziale del contenuto di questo Catalogo Tecnico. Non si possono accettare responsabilità per eventuali errori od omissioni. Le misure non sono impegnative. Marchio registrato Italia - UE.

The reproduction, even partial, of the contained concerning this Technical Catalogue, is forbidden. Liability for possible errors and/or omissions are not accepted. Sizes are not binding. TM Registered in Italy - UE.



**CATENE
CHAINS**

1.1.08 ©Copyright 



79992000