

Motori asincroni trifase / Asynchronous three-phase motors
2 Poli / poles
MOTORE / MOTOR

	Motore Motor	Classe energetica Energy class	Grandezza Size	Potenza kW Power kW	Numero di poli Number of poles	Forma costruttiva Version
ES. DESIGNAZIONE EX. DESIGNATION	M	1	063	0.25	2P	B5
ES. CODICE EX. CODE	M	1	063	025	2	B5

Caratteristiche tecniche 2 Poli - 2800 rpm / Technical characteristics 2 Poles - 2800 rpm

Codice code			Tipo Type	Potenza Power	Tensione Voltage	Corrente Current	Classe energetica Energy class	Rendimento Efficiency	Fattore di potenza Power factor	Coppia nominale Rated torque	Coppia spunto / Cn Starting torque / Cn	Peso Weight		
B5	B3	B14		kW	V	A (400V)		%	cos Φ	Cn (Nm)	Cs/Cn	B3 (kg)	B5 (kg)	B14 (kg)
M10560092B5	M10560092B3	M10560092B14	56A	0.09	230/400	0.36	IE1	53	0.72	0.502	2.2	2.6	2.8	2.8
M10560122B5	M10560122B3	M10560122B14	56B	0.12	230/400	0.40	IE1	61	0.72	0.534	2.2	3	3.2	3.2
M10630182B5	M10630182B3	M10630182B14	63A	0.18	230/400	0.55	IE1	63	0.75	0.641	2.2	4	4.2	4.2
M10630252B5	M10630252B3	M10630252B14	63B	0.25	230/400	0.71	IE1	65	0.78	0.884	2.2	4.2	4.5	4.5
M10630372B5	M10630372B3	M10630372B14	63C	0.37	230/400	1.05	IE1	65	0.78	1.264	2.2	4.7	5.2	5.2
M10710372B5	M10710372B3	M10710372B14	71A	0.37	230/400	0.97	IE1	70	0.79	1.262	2.2	5.2	5.5	5.5
M10710552B5	M10710552B3	M10710552B14	71B	0.55	230/400	1.42	IE1	71	0.79	1.869	2.2	6	6.8	6.8
M20800752B5	M20800752B3	M20800752B14	80A	0.75	230/400	1.86	IE2	77.4	0.75	2.51	2.7	9.3	9.4	9.3
M20801102B5	M20801102B3	M20801102B14	80B	1.1	230/400	2.52	IE2	79.6	0.79	3.69	2.7	10.5	10.6	10.5
M20901502B5	M20901502B3	M20901502B14	90S	1.5	230/400	3.17	IE2	81.3	0.84	5.02	2.3	13.5	12.8	12.7
M20902202B5	M20902202B3	M20902202B14	90L	2.2	230/400	4.54	IE2	83.2	0.84	7.38	2.6	16.2	16.2	15.9
M21003002B5	M21003002B3	M21003002B14	100L	3	230/400	5.75	IE2	84.6	0.89	10.05	2.5	23.2	23.3	23.2
M21124002B5	M21124002B3	M21124002B14	112M	4	400/690	7.56	IE2	85.8	0.89	13.13	2.5	27.2	27.3	27.2
M21325502B5	M21325502B3	M21325502B14	132SA	5.5	400/690	10.25	IE2	87	0.89	18.08	2.4	42.6	45.3	42.6
M31327502B5	M31327502B3	M31327502B14	132SB	7.5	400/690	13.65	IE3	90.1	0.88	24.61	2.7	45.4	45.6	45.4

Nota:

I dati tecnici indicati in tabella si riferiscono ad una tensione di alimentazione di 400 V, 50 Hz.

Note:

Technical characteristics are referred to voltage 400 V, 50 Hz.

Motori asincroni trifase / Asynchronous three-phase motors
6 Poli / poles
MOTORE / MOTOR

	Motore Motor	Classe energetica Energy class	Grandezza Size	Potenza kW Power kW	Numero di poli Number of poles	Forma costruttiva Version
DESIGNAZIONE DESIGNATION	M	2	080	0.37	6P	B5
CODICE CODE	M	2	080	037	6	B5

Caratteristiche tecniche 6 Poli - 900 rpm / Technical characteristics 6 Poles - 900 rpm

Codice code			Tipo Type	Potenza Power	Tensione Voltage	Corrente Current	Classe energetica Energy class	Rendimento Efficiency	Fattore di potenza Power factor	Coppia nominale Rated torque	Coppia spunto / Cn Starting torque / Cn	Peso Weight		
B5	B3	B14		kW	V	A (400V)		%	cos Φ	Cn (Nm)	Cs/Cn	B3 (kg)	B5 (kg)	B14 (kg)
M10630126B5	M10630126B3	M10630126B14	63B	0.12	230/400	0.62	IE1	45	0.62	1.18	2	4.5	4.8	4.8
M10710186B5	M10710186B3	M10710186B14	71A	0.18	230/400	0.70	IE1	56	0.66	1.93	1.7	5.6	6.1	6.1
M10710256B5	M10710256B3	M10710256B14	71B	0.25	230/400	0.87	IE1	59	0.7	2.36	2.1	6	6.8	6.8
M10710376B5	M10710376B3	M10710376B14	71C	0.37	230/400	1.27	IE1	61	0.69	3.93	2	6.8	7.6	7.6
M10800376B5	M10800376B3	M10800376B14	80A	0.37	230/400	1.23	IE1	62	0.7	3.9	1.9	8.1	8.9	8.9
M10800556B5	M10800556B3	M10800556B14	80B	0.55	230/400	1.65	IE1	67	0.72	5.84	2	9.6	10.6	10.6
M20900756B5	M20900756B3	M20900756B14	90S	0.75	230/400	1.88	IE2	75.9	0.76	7.66	2.2	12.9	13.2	12.9
M20901106B5	M20901106B3	M20901106B14	90L	1.1	230/400	2.54	IE2	78.1	0.80	11.23	2.3	14.9	15.7	14.9
M21001506B5	M21001506B3	M21001506B14	100L	1.5	230/400	3.31	IE2	79.8	0.82	15.24	2.3	20.7	20.8	20.7
M21122206B5	M21122206B3	M21122206B14	112M	2.2	230/400	4.85	IE2	81.8	0.80	22.35	2.3	33.3	34.5	33.3
M21323006B5	M21323006B3	M21323006B14	132S	3	230/400	6.26	IE2	83.3	0.83	30.48	2.4	38.3	39.5	38.3
M21324006B5	M21324006B3	M21324006B14	132MA	4	400/690	8.12	IE2	84.6	0.84	40.42	2.5	43.3	44.4	43.3
M21325506B5	M21325506B3	M21325506B14	132MB	5.5	400/690	11.26	IE2	86	0.82	55.58	2.3	58.2	59.1	58.2

Nota:

I dati tecnici indicati in tabella si riferiscono ad una tensione di alimentazione di 400 V, 50 Hz.

Note:

Technical characteristics are referred to voltage 400 V, 50 Hz.

Dimensioni d'ingombro / Dimensions

Tipo/ Type	B3 / B5 / B14				
	D	E	F	O	SS
56	Ø9	20	3	10.2	M3
63	Ø11	23	4	12.5	M4
71	Ø14	30	5	16	M5
80	Ø19	40	6	21.5	M6
90S	Ø24	50	8	27	M8
90L	Ø24	50	8	27	M8
100	Ø28	60	8	31	M10
112	Ø28	60	8	31	M10
132S	Ø38	80	10	41	M12
132M/L	Ø38	80	10	41	M12
160M/L	Ø42	110	12	45	M16

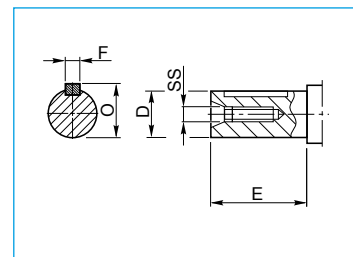
Albero / Shaft

Dimensioni d'ingombro motori IE1 / Dimensions motors IE1

Tipo/ Type	B3							B5					B14					B3 / B5 / B14		
	H	A	AA	AD	B	C	K	M	N	P	T	S	N	M	P	T	S	HD	AC	L
56	56	90	110	156	71	36	5.8X8.8	Ø100	Ø80	Ø120	3	Ø7	Ø50	Ø65	Ø80	2.5	M5	100	Ø117	196
63	63	100	120	171	80	40	7X10	Ø115	Ø95	Ø140	3	Ø10	Ø60	Ø75	Ø90	2.5	M5	108	Ø130	220
71	71	112	132	186	90	45	7X10	Ø130	Ø110	Ø160	3.5	Ø10	Ø70	Ø85	Ø105	2.5	M6	115	Ø147	241
80	80	125	160	213	100	50	10X13	Ø165	Ø130	Ø200	3.5	Ø12	Ø80	Ø100	Ø120	3	M6	133	Ø163	290
90S	90	140	175	229	100	56	10X13	Ø165	Ø130	Ø200	3.5	Ø12	Ø95	Ø115	Ø140	3	M8	139	Ø183	312
90L	90	140	175	229	125	56	10X13	Ø165	Ø130	Ø200	3.5	Ø12	Ø95	Ø115	Ø140	3	M8	139	Ø183	337/367
100	100	160	198	252	140	63	12X15	Ø215	Ø180	Ø250	4	Ø15	Ø110	Ø130	Ø160	3.5	M8	152	Ø205	369
112	112	190	220	279	140	70	12X15	Ø215	Ø180	Ø250	4	Ø15	Ø110	Ø130	Ø160	3.5	M8	167	Ø229	395
132S	132	216	252	318	140	89	12X15	Ø265	Ø230	Ø300	4	Ø15	Ø130	Ø165	Ø200	4	M10	186	Ø265	437
132M/L	132	216	252	318	178	89	12X15	Ø265	Ø230	Ø300	4	Ø15	Ø130	Ø165	Ø200	4	M10	186	Ø265	475/501
160M/L	160	254	290	384	210/254	108	15X19	Ø300	Ø250	Ø350	5	Ø19	Ø180	Ø215	Ø250	4	M12	224	Ø325	640

Nota:
Dimensioni dei motori IE1 e IE2 contattare servizio tecnico SATI

Note:
Dimensions of motors IE1 e IE2, contact the technical department SATI.

B3

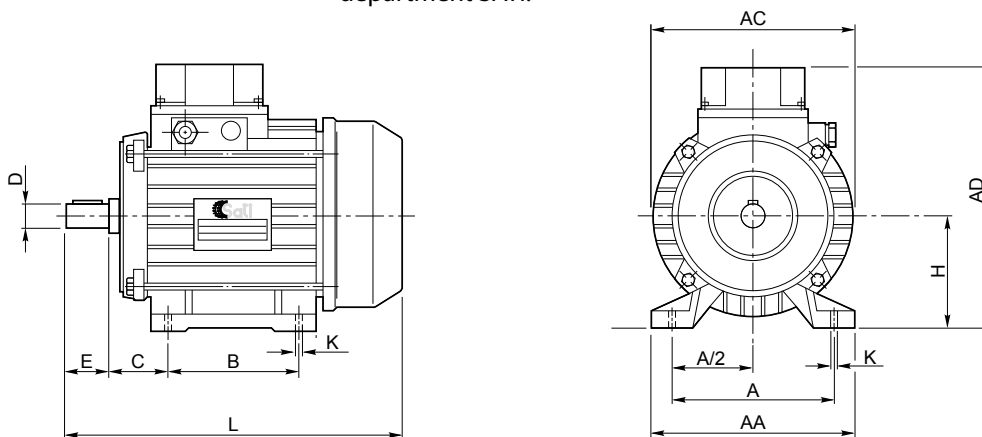

B5

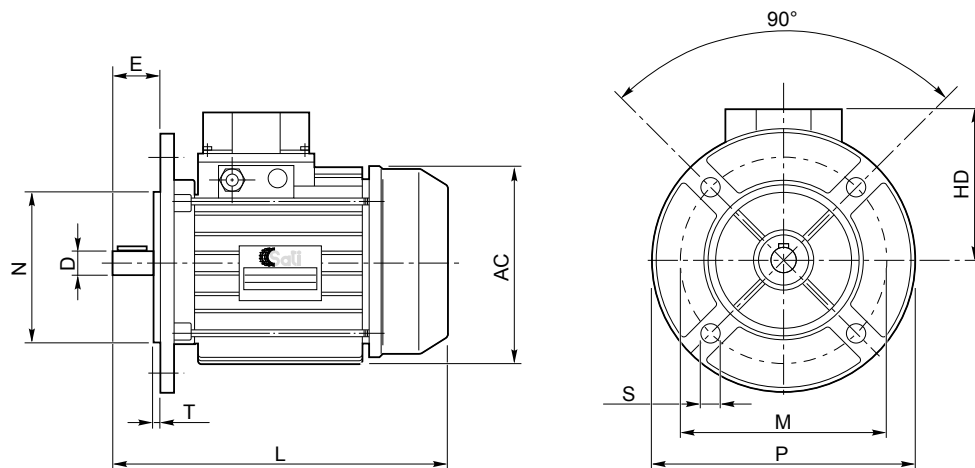

B14

