

Models HSR-M1A and HSR-M1LA

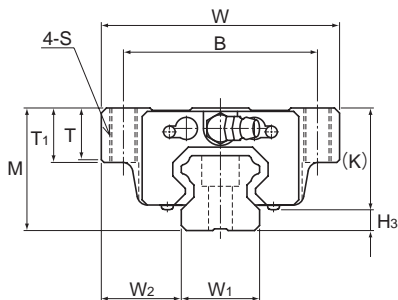

Model No.	Outer dimensions			LM block dimensions										Grease nipple	H ₃
	Height	Width	Length	B	C	S	L ₁	T	T ₁	K	N	E			
	M	W	L												
HSR 15M1A	24	47	59.6	38	30	M5	38.8	6.5	11	19.3	4.3	5.5	PB1021B	3.5	
HSR 20M1A HSR 20M1LA	30	63	76 92	53	40	M6	50.8 66.8	9.5	10	26	5	12	B-M6F	4	
HSR 25M1A HSR 25M1LA	36	70	83.9 103	57	45	M8	59.5 78.6	11	16	30.5	6	12	B-M6F	5.5	
HSR 30M1A HSR 30M1LA	42	90	98.8 121.4	72	52	M10	70.4 93	9	18	35	7	12	B-M6F	7	
HSR 35M1A HSR 35M1LA	48	100	112 137.4	82	62	M10	80.4 105.8	12	21	40.5	8	12	B-M6F	7.5	

Note) The length L of the high temperature type LM Guide model HSR is longer than normal type of model HSR. (Dimension L₁ is the same.)

Model number coding

HSR25 M1 A 2 UU C1 +1240L P T - II

Model number

Type of LM block

Contamination protection accessory symbol (*1)

LM rail length (in mm)

Symbol for LM rail jointed use

Symbol for No. of rails used on the same plane (*4)

Symbol for high temperature type LM Guide

No. of LM blocks used on the same rail

Radial clearance symbol (*2)
Normal (No symbol)
Light preload (C1)
Medium preload (C0)

Accuracy symbol (*3)
Normal grade (No Symbol)/High accuracy grade (H)
Precision grade (P)/Super precision grade (SP)
Ultra precision grade (UP)

(*1) See contamination protection accessory on A-368. (*2) See A-114. (*3) See A-119. (*4) See A-59.

Note) This model number indicates that a single-rail unit constitutes one set. (i.e., required number of sets when 2 rails are used in parallel is 2 at a minimum.)

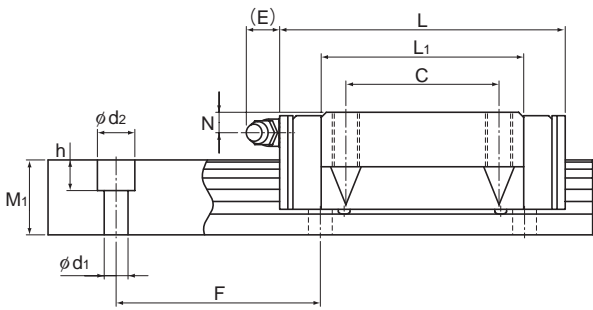

Unit: mm

LM rail dimensions						Basic load rating		Static permissible moment kN-m*					Mass	
Width	Height	Pitch		Length*	C	C ₀	M _A		M _B		M _C	LM block	LM rail	
W ₁ ±0.05	W ₂	M ₁	F	d ₁ × d ₂ × h	Max	kN	kN	1 block	Double blocks	1 block	Double blocks	1 block	kg	kg/m
15	16	15	60	4.5 × 7.5 × 5.3	1240	8.33	13.5	0.0805	0.457	0.0805	0.457	0.0844	0.2	1.5
20	21.5	18	60	6 × 9.5 × 8.5	1500	13.8 21.3	23.8 31.8	0.19 0.323	1.04 1.66	0.19 0.323	1.04 1.66	0.201 0.27	0.35 0.47	2.3
23	23.5	22	60	7 × 11 × 9	1500	19.9 27.2	34.4 45.9	0.307 0.529	1.71 2.74	0.307 0.529	1.71 2.74	0.344 0.459	0.59 0.75	3.3
28	31	26	80	9 × 14 × 12	1500	28 37.3	46.8 62.5	0.524 0.889	2.7 4.37	0.524 0.889	2.7 4.37	0.562 0.751	1.1 1.3	4.8
34	33	29	80	9 × 14 × 12	1500	37.3 50.2	61.1 81.5	0.782 1.32	3.93 6.35	0.782 1.32	3.93 6.35	0.905 1.2	1.6 2	6.6

Note) The maximum length under "Length*" indicates the standard maximum length of an LM rail. (See B-190.)
 Static permissible moment*: 1 block: static permissible moment value with 1 LM block
 Double blocks: static permissible moment value with 2 blocks closely contacting with each other