

Dial gauges – Electronic and Analogue

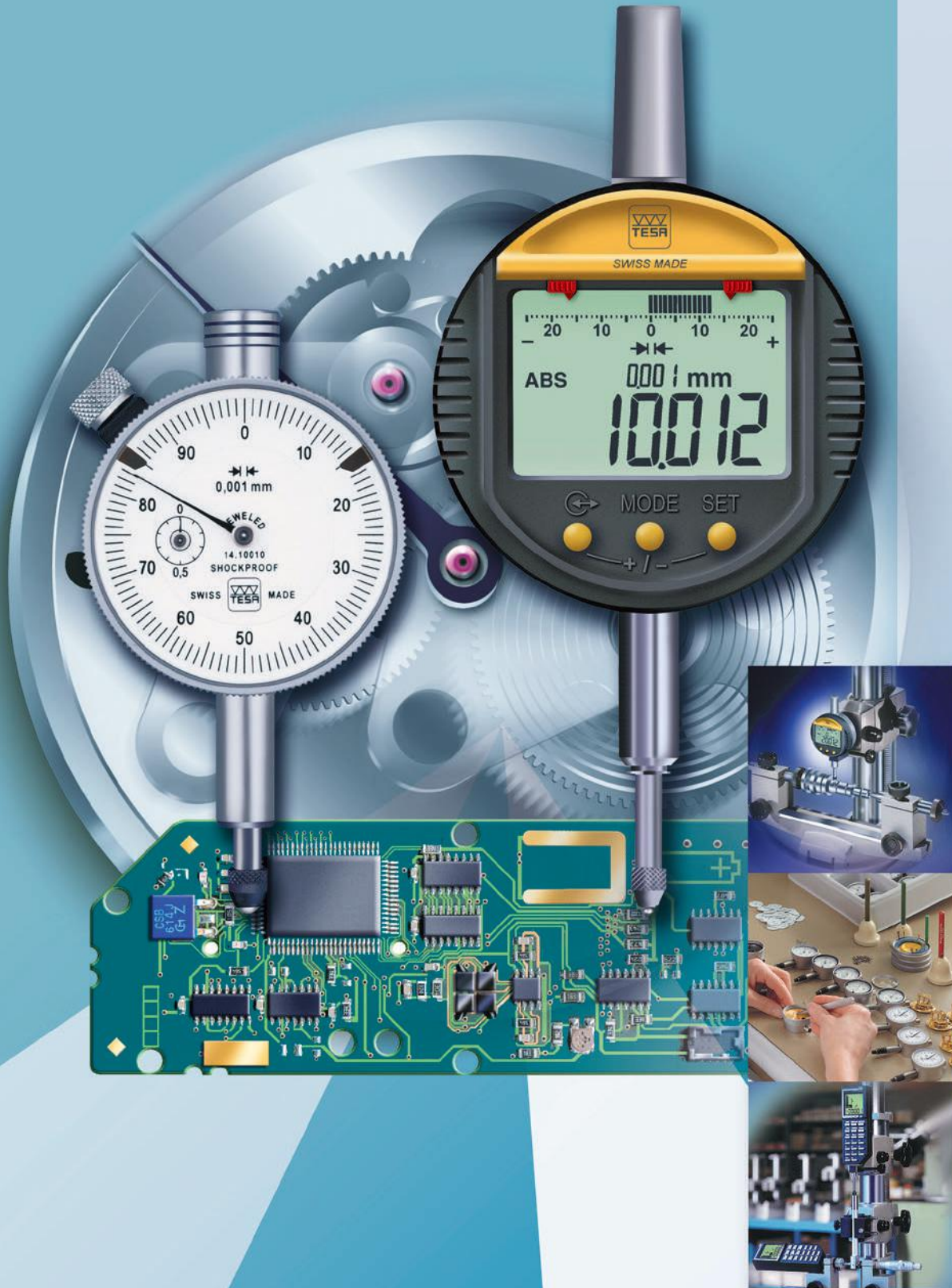

EASY-TO-USE AND VERSATILE

For more than 50 years we have been producing and distributing a wide range of easy-to-use and versatile dial gauges. Our experience allows us to offer a wide choice of different models.

- Electronic indicators with combined analogue/digital display using the most up-to-date technology.
- Mechanical dial gauges equipped with high-precision movements and double-action shockproof mechanisms. Measuring spans up to 100 mm.

CHOICE OF DIAL GAUGE OR ELECTRONIC INDICATOR

- Digital indication provides error-free reading of the measured value. There is no need to read fractions of scale divisions.
- Analogue indication offers the advantage of being able to smoothly adjust the increase or decrease of the dimension to be measured on the workpiece. This type of indication is best suited for dynamic measurements such as determining axial and radial runout errors.
- Electronic indicators provide many additional functions compared to the mechanical models. For more information, refer to the section on electronic indicators.
- The inspection of axial and radial runout errors frequently requires the use of instruments with the lowest hysteresis characteristic. Our electronic indicators, precision dial gauges and dial test indicators meet this requirement.
- In order to significantly reduce the effect of systematic errors, it is recommended to carry out comparative measurements. Only deviations from the nominal dimension will be displayed. High precision, small range electronic indicators are the ideal instruments for these types of measurements.
- These same instruments also enable avoiding major errors in reading millimetres.

STANDARDS AND DEFINITIONS

The international ISO 463:2006 standard replaces national standards dealing with mechanical dial gauges. All the same, new definitions and standard requirements pertaining to measuring procedures, although valid, imply changes in design and metrological characteristics, which cannot be entirely indicated in this catalogue. This standard, is defined in the matrix "Product Specification (GPS) - dimensional measuring instruments". It only defines the requirements for the most important characteristics.

Therefore, all tolerance limits indicated in this catalogue which refer to metrological characteristics are based on our own internal standards.

Electronic indicators and short range precision indicators. Definitions used in this section:



Total permissible error in 1 measuring direction over the entire measuring range within the partial measuring range

in the 2 measuring directions



Repeatability limit



Max. hysteresis

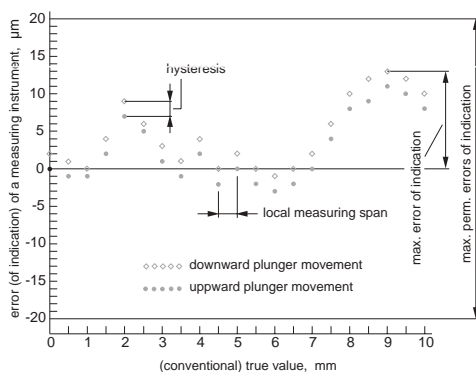

Mechanical dial gauges.

Definitions used in this section for the maximum permissible errors of a metrological characteristic (MPE):



Deviation span (error of indication within the measuring range)

Deviation span (error of indication) within the partial measuring range

Total deviation span (error of indication within the measuring range)



Repeatability limit (reliability) of indication



Hysteresis of indication

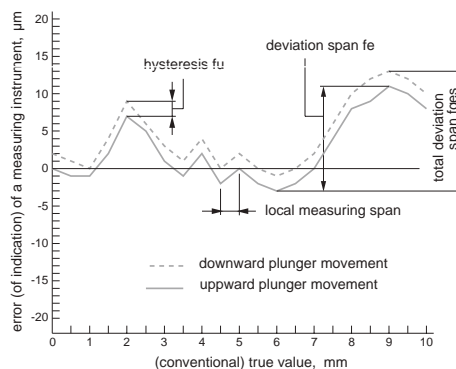

TESA DIGICO 205 / 305

- Dual LC Display, digital and analogue.
- Mechanical tolerance markers.
- Dimensions according to DIN 878.

Main functions

ON/Auto OFF - Data output - Counting sense reversal - Keypad lock.

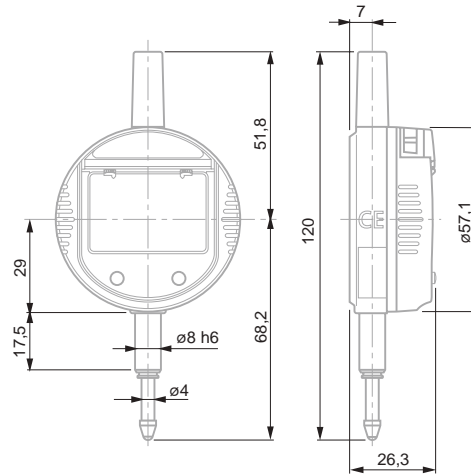

- Resolution 0,01 mm = ±0,25 mm
Resolution to 0,001 mm = ±0,025 mm
- 6-decade LC display field, plus minus sign
- Digit size 10 x 5 mm (H x L)
- Combined analogue and numerical display
- Glass scale with incremental divisions, capacitive
- MI or MIE type: metric/inch conversion
- ≤ 2 N
- ≤ 2 m/s
- Full-metal housing with front face in polyamide. Stainless steel plunger. M2,5 mounting thread for measuring insert.
- RS232, opto-coupled
- 3V lithium battery type CR2032
- 1 year to 2 years
- 10°C to 40°C
- 10°C to 60°C
- ~80 %
- EN 50081-1
EN 50082-1
- 150 g
- Transport case with 1 lithium battery 01961000
- Identification number
- Inspection report with declaration of conformity

No	=						
		mm	in	mm	in	µm	µm
01930230	DIGICO 205 MI	12,5	0.5	0,01	0.0005	20	10
01930231	DIGICO 305 MI	12,5	0.5	0,001	0.00005	8	2



TESA DIGICO 400 / 500

- Measuring modes ABS/REL.
- Dual LC Display, digital and analogue
- Rotation through 270° of display and key functions.
- Mechanical tolerance marks.
- Graphical display of tolerance limits.

Measuring functions and modes

ON - Auto OFF - PRESET mode - Tolerance mode - Data output - Counting sense reversal - Keypad lock - Metric/Inch units - Full RESET.

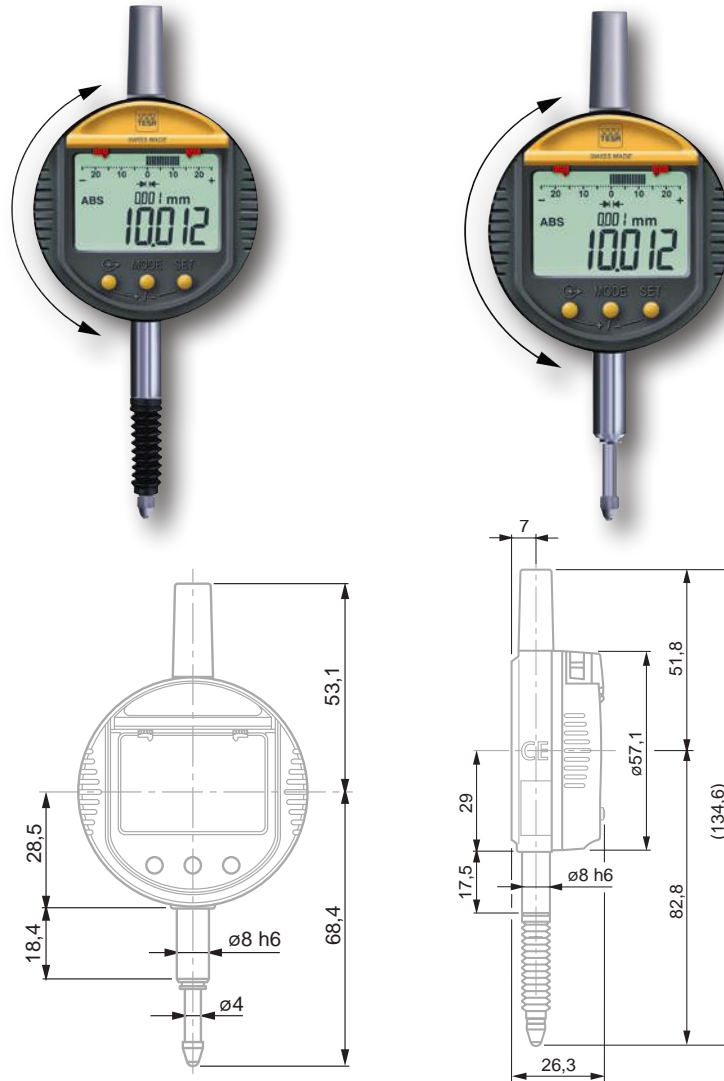

- Resolution 0,01 mm = ±0,25 mm Resolution 0,001 mm = ±0,025 mm
- 6-decade LC display field plus minus sign
- Digit size 10 x 5 (H x L)
- Combined analogue and numerical display
- Glass scale with incremental divisions, capacitive
- Conversion mm/in
- Measuring force: < 2 N
- ≤ 2 m/s
- Full-metal housing, front face in polyamide, Stainless steel plunger, M2,5 mounting thread for measuring insert.
- RS232, opto-coupled
- 3V lithium battery, type CR2032
- 1 year to 2 years
- 10°C to 40°C
- 10°C to 60°C
- 80 %
- EN 50081-1 EN 50082-1
- Shipping case including one lithium battery 01961000
- Identification number
- Inspection report with declaration of conformity

No	=								
01930241	DIGICO 410 MI	25	1	0,01	0.0005	20	10	-	162
01930255	DIGICO 505 MIP, protected	12,5	0.5	0,001	0.00005	4	2	IP62	150



Resolution 0,01 mm
= ± 0,25 mm Resolution
0,001 mm =
± 0,025 mm



6-decade LC display
field plus minus sign



Digit size 10 x 5 mm
(H x L)



Combined analogue
and numerical
display



Glass scale with in-
cremental divisions,
capacitive



Conversion mm/in



Measuring force:
< 2 N



≤ 2 m/s



Full-metal housing
with front face in
polyamide. Stainless
steel plunger.
M2,5 mounting
thread for mea-
suring insert.



RS232,
opto-coupled



3V lithium battery,
type CR2032



1 year to 2 years



10°C to 40°C



-10°C to 60°C



80 %



EN 50081-1
EN 50082-1



Transport case with
1 lithium battery
01961000



Identification
number



Inspection report
with eclaration of
conformity

TESA DIGICO 600

- Measuring modes ABS/REL.
- Dual LC Display.
- Display rotation through 270°. Same goes for the key functions.
- Mechanical tolerance marks.
- Graphical display of tolerance limits.

Measuring functions and modes

ON – Auto OFF – PRESET mode – Tolerance mode – Measured value storage

- Max • Min • Max-Min (TIR) – Data output – Counting sense reversal – Keypad lock – Metric/Inch units – Full RESET.

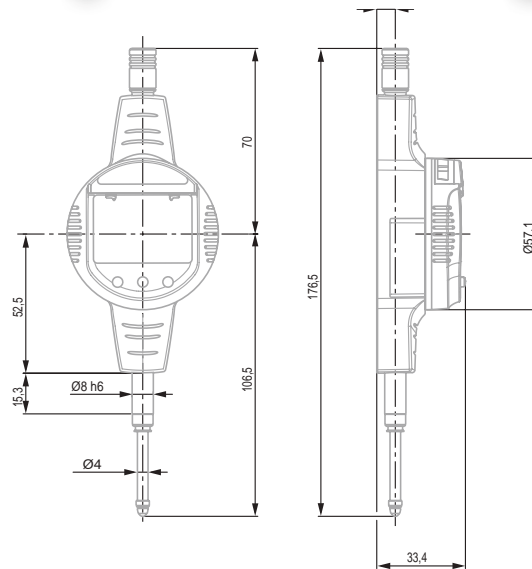

No	=							
01930256	DIGICO 605 MI	12,5	0,5	0,001	0.00005	4	2	150
01930257	DIGICO 610 MI	25	1	0,001	0.00005	5	2	162



TESA DIGICO 705

For use with 2-point contact bore gauges. Allows setting of the dial gauge to the smallest setting ring value.

- Same functions as DIGICO 600.



- Resolution to 0,01 mm = ± 0,25 mm
Resolution 0,001 mm = ± 0,025 mm
- 6-decade LC display field, plus minus sign
- Digit size 10 x 5 mm (H x L)
- Combined analogue and numerical display
- Glass scale with incremental divisions, capacitive
- Conversion mm/in
- Measuring force < 2 N
- ≤ 2 m/s
- Full-metal housing with front face in polyamide. Stainless steel plunger, M2,5 mounting thread for the measuring insert.

01930258	DIGICO 705 MI	12,5	0.5	0,001	0.00005	4	2	150

- RS232, opto-coupled
- 3V lithium battery, type CR2032
- 1 to 2 years
- 10°C to 40°C
- 10°C to 60°C
- 80 %
- EN 50081-1 EN 50082-1
- Transport case with 1 lithium battery 01961000
- Identification number
- Inspection report with declaration of conformity

Accessories for TESA DIGICO 200 – 700

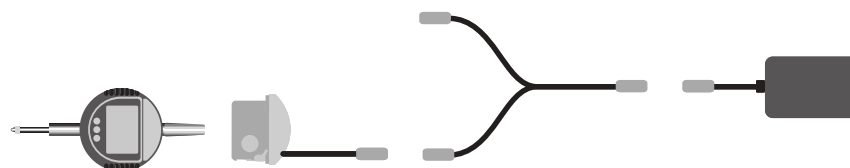

01962002		External power supply
01961000		Lithium battery, 3V, CR2032
04761054		Battery charger 100 ÷ 200 VAC / 50 ÷ 60 Hz, 6,6 Vdc, 750 mAh supplied without power cable
04761055		Cable EU for charger 0471054
04761056		Power cable US for charger 0471054

- Measuring inserts, see chapter "Measuring inserts for dial gauges, axial probes and other hand tools".
- Backs and retraction devices, see chapter "Devices for plunger retraction" and "Backs for Dial Gauges".
- Connectivity, see corresponding chapter.

- According to selected tolerances
- 30,4 mm (DIGICO 1) or 60,4 mm (DIGICO 2)
- 40 mm scale length
- 25 divisions
- According to selected tolerances
- 6 decades plus minus sign
- See table
- 9 x 4,5 mm digit size (H x W)
- LC display with backlight
- Incremental glass scale
- Metric/inch conversion
- DIGICO 1: 2 µm
DIGICO 2: 3 µm
- 1 µm
- 1 µm
- See table for measuring forces
- DIGICO 1: max. 1 m/s
DIGICO 2: max. 2 m/s
- Plunger guided on a plain bearing M2,5 mounting thread for measuring insert.
- RS232
- 3,6 V lithium battery or mains adapter
- ≈ 1000 h with lithium battery
- 0,002%/°C
- 10°C to 40°C
- 10°C to 50°C
- DIGICO case in standard execution: IP54 (IEC 60529)
-
- 290 g (DIGICO 1)
310 g (DIGICO 2)
Moved mass through the plunger:
28 g (DIGICO 1)
27 g (DIGICO 2)
- Supplied in transport packing with 1 lithium battery
01960007
1 lift lever 01960005
- Identification number
- Inspection report with a declaration of conformity

TESA DIGICO 1 / 2

These two indicators are remarkable for their multiple simple functions, long measuring travel and high accuracy.

- Analogue/digital display combined with the possibility of orienting the analogue display in different positions.
- Zero setting at any point within the measuring span.
- Data input via the keypad.
- Counting direction reversible.
- Entry of limit values for classification through displayed symbols. Additional green, red or amber coloured background whenever the instrument is connected to mains.
- Storage of measured values through the functions: "Maximum value", "Minimum value" or "Maximum value minus minimum value".

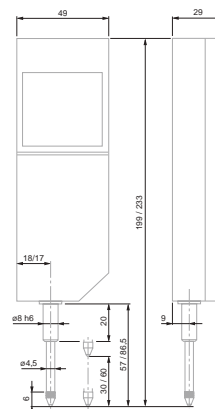

No	=				
		mm	in	mm	in
01930000	DIGICO 1	30	1.18	0,001	0.00005
01930001	DIGICO 2	60	3.36	0,001	0.00005

OPTIONAL ACCESSORIES:

- 04761037 Mains adaptor 230V for DIGICO 1 or 2
- 04761057 Mains adaptor 110V for DIGICO 1 or 2
- 01960007 3.5 V lithium battery, LR6, AA
- 01960005 Bottom mounted lift lever
- 04768000 Hand switch for manually triggering data transfer.
Jack plug connector, 1,8 m
- TESA SPC PRINTER printer
- TESATRONIC TT display units

Force de mesure		
	DIGICO 1	DIGICO 2
Measuring force* close to measuring plunger stop		
- Bottom	0.85 N ± 0.15 N	0.90 N ± 0.20 N
- Top	1.10 N ± 0.20 N	1.45 N ± 0.25 N
Hysteresis*	0.10 N	0.15 N

* Valid with indicator in vertical position, measuring plunger oriented downwards and in static measurement.



TESA DIGICO 12

Designed to operate in a rugged environment, resistant to spray of liquids (IP65)
 – 44 mm dial diameter – Provides the advantages of mechanical precision with digital reading

TESA DIGICO 12 – Standard

- 44 mm dial casing diameter.
- Resistant against cutting oils and coolants (IP65).
- RS232 SIMPLEX data output combined with external power supply.
- Inductive measuring system, patented.
- Choice between absolute "ABS" and relative "REL" measuring modes.
- Digital display.
- Setting of PRESET value (± 130 mm).
- Inverse measuring direction.
- Direct conversion of metric/inch units.
- Automatic shutdown.

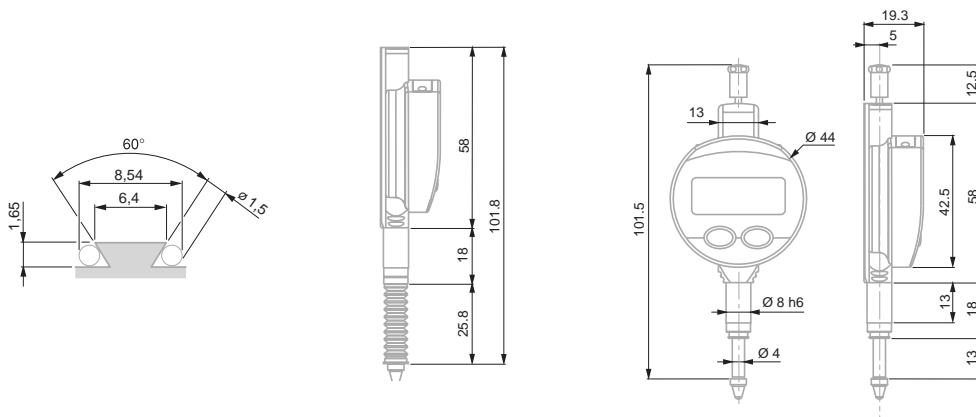

- 5-digit LC display + sign
- Digit height 6 mm
- 20 μ m
- Repeatability: 5 μ m
- 0,5 to 0,9 ($\pm 0,15$) N
- Max. 2 m/sec
- Number of measurements per second: 7
- Zero setting of display
- RS232
- 3 V lithium battery, type CR 3032
- Battery life > 3500 hours
- Working temperature range: 5°C to 40°C
- Protection level: IP65 (CEI 629)
- EN 61326-1
- 70 g
- Supplied in transport packing with 1 lithium battery, type CR 2032 (No 01961000)
- Identification number
- Declaration of conformity
- Models 0,01 mm with report, models 0,001 mm without report

	mm	in	mm	in	Protection bellows	
01930130	12,5	0.5	0,01	0.0005		IP65
01930132	12,5	0.5	0,001	0.00005		IP65
01930131	12,5	0.5	0,01	0.0005	With	IP65
01930133	12,5	0.5	0,001	0.00005	With	IP65

- +
- LCD, 5 digits + sign
- Digit height: 6 mm
- Max. permissible error: 4 µm
- Repeatability limit: 2 µm
- 0,4 to 0,75 (± 0,15) N
- Max. 2 m/sec
- Number of measurements per second: 9
- Zero-setting of display
- RS232
- 3 V lithium battery, type CR 2032
- Battery life: > 4000 hours
- Working temperature range: 5°C to 40°C
- IP65 (CEI 529)
- EN 61326-1
- 70 g
- Supplied in transport packing with 1 lithium battery, type CR 2032 (No 01961000)
- Identification number
- Inspection report with a declaration of conformity

TESA DIGICO 12 – HP

- High precision measuring system.
- Resistant to cutting oils and coolants (IP65).
- Combined analogue/digital display.
- Analogue reading from ±0.025 to ±1.25 mm.
- NOR/MIN/MAX/MAX-MIN measuring modes.
- 44 mm dial casing diameter.
- RS 232 data output combined with external power supply.
- Inductive measuring system, patented.
- Zero-setting of display.
- Direct conversion of metric/inch units.
- Shut down: either automatic or blocked.

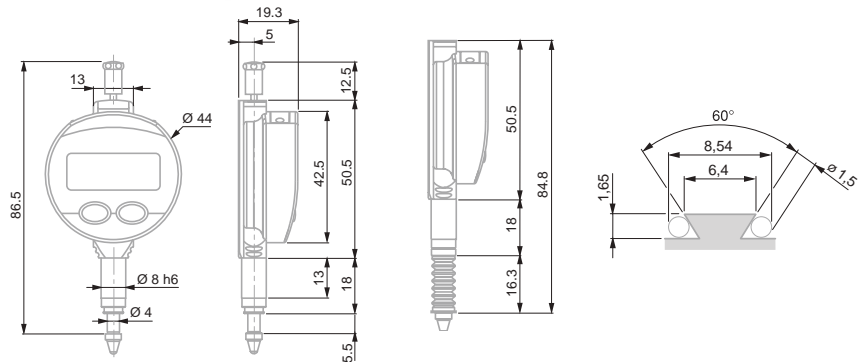

No					Protection bellows	
01930134	5	0.210	0,001	0.00005	Without	IP65
01930135	5	0.210	0,001	0.00005	With	IP65

Accessories for TESA DIGICO 12

No	=
03238013	Mounting lug
01961012	Upper lift lever
01960005	Bottom mounted lift lever
04761060	RS 232 cable with external power supply
01961000	Lithium battery, 3V, CR2032

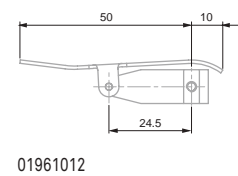
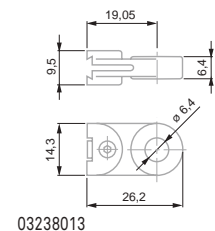

ETALON HP

High precision comparators

ETALON with short measuring travel

The ultimate in high precision.

Remarkably reliable, even when constantly used for series inspection – Specially designed for comparative measurements requiring a very low measurement uncertainty – Measures axial and radial runouts with very low hysteresis.

- Shockproof movement. Lever and gear transmission system. Long dead travel.
- Non-reflecting dial for easy readout.
- Measuring travel limited to less than one revolution of pointer. No possibility of reading errors.
- Fine adjustment with protective knob to prevent accidental displacement of the pointer.



DIN 879-1 Dimensions according to EN ISO 463



Full-metal dial casing. Stainless steel plunger, hardened.



≈1 N



Measuring plunger on ball-bearings



Adjustable tolerance markers. Coupling thread for retraction cable. M2,5 thread for measuring insert



1 measuring insert already mounted, steel ball tip Ø 3.175 mm. 1 retraction cable.



Plastic case



Declaration of conformity

01419051		0,1	0,001	3,0	50 ÷ 0 ÷ 50 ●	62	–
01419052		0,1	0,001	3,0	50 ÷ 0 ÷ 50 ●	62	IP54

Accuracy

	0,001 mm
	Max. perm. errors in one direction throughout the measuring range, G_e 1 μ m
	over any selected local range including 10 scale divisions, G_t 0,7 μ m
	in both measuring directions throughout the total measuring range, G_{ges} 1,2 μ m
	Repeatability limit, r_w 0,5 μ m
	Max. hysteresis, f_u 0,5 μ m

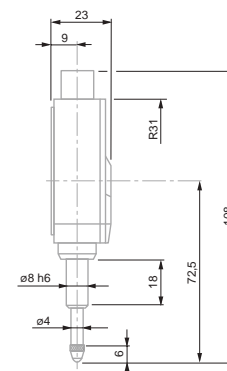

DIAL GAUGES – PREMIUM QUALITY

The TOP quality of our dial gauges guarantee the use of the best and most wear-resistant materials in order to ensure that the most demanding metrological criteria are respected along with a product life that exceeds all other dial gauges

Dial Ø 40 mm – Reading 0,01 mm

Precision dial gauges

These precision dial gauges combine excellent metrological properties with extra-long life.

- Smooth and regular travel, entirely jewel-mounted movement.
- Full-metal dial casing and bezel.
- Shockproof mechanism in both directions of plunger movement.
- Non-reflecting dial.
- Swiss-made.



01410210

353

353E

- EN ISO 463 Factory standard
- Rotating dial. With or without dial lock for standard models
- 0,01 mm
- Full-metal dial casing. Mounting shank and plunger in hardened stainless steel
- See table for tolerance limits
- With or without shockproof mechanism
- Adjustable tolerance markers. Thread M2,5 for measuring insert
- Measuring insert with 3 mm dia. ball tip already mounted
- Cardboard box
- Identification number
- Inspection report with a declaration of conformity

No	=											
		mm	mm	mm	mm							N
01410210	TESA YR	5	5,4	0,01	0,5	0 ÷ 25 ÷ 50	●	●				
01416013	MERCER X185-1	5	5,4	0,01	0,5	0 ÷ 25 ÷ 0	–	●				
01416014	MERCER 186-1	5	5,4	0,01	0,5	0 ÷ 25 ÷ 50	–	●				
01412010	TESA YE	5	5,4	0,01	0,5	0 ÷ 25 ÷ 50	–	–				
353	COMPAC 353	5	5,4	0,01	0,5	0 ÷ 25 ÷ 50	●	–				
353E	COMPAC 353E IP54	5	5,4	0,01	0,5	0 ÷ 25 ÷ 50	●	–				IP54

Permissible limits of a metrological characteristic (MPE/MPL)

		0,01 mm
	Deviation span	12 µm
	Deviation span within partial measuring span 0,10 mm	6 µm
	Total deviation span	14 µm
	Repeatability limit	3 µm
	Max. hysteresis	3 µm
	Measuring force	= 1,4 N
	– IP54 model	= 2 N

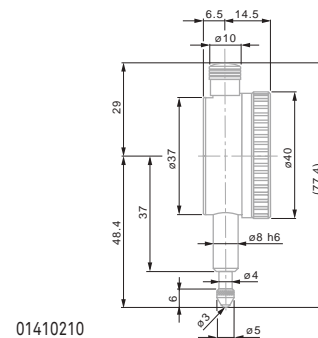

01410210

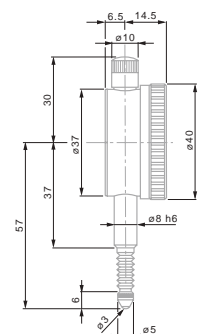

353E



Dial Ø 57 and 58 mm – Reading 0,01 mm

Precision dial gauges



01410610



512K



532E



01416021

No	=												
		mm	mm	mm	mm								
01410610	TESA YR	10	10,5	0,01	1	0 ÷ 50 ÷ 100	●	●					
01410611	TESA YR	10	10,5	0,01	1	0 ÷ 50 ÷ 0	●	●					
01412310	TESA YE	10	10,5	0,01	1	0 ÷ 50 ÷ 100	-	-					
01416021	MERCER 251-1	10	10,5	0,01	1	0 ÷ 50 ÷ 100	-	●					
512K	COMPAC 512K	10	10,5	0,01	1	0 ÷ 50 ÷ 100	-	-					
532	COMPAC 532	10	10,5	0,01	1	0 ÷ 50 ÷ 100	●	-					
532E	COMPAC 532E IP54	10	10,5	0,01	1	0 ÷ 50 ÷ 100	●	-				IP54	
533S	COMPAC 533S limited travel	± 0.5	4	0,01	1,27	50 ÷ 0 ÷ 50	●	-					

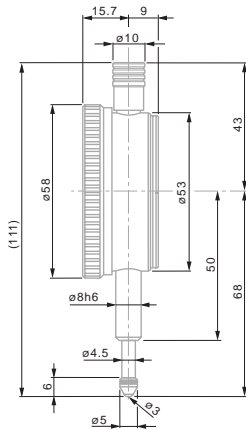

512K

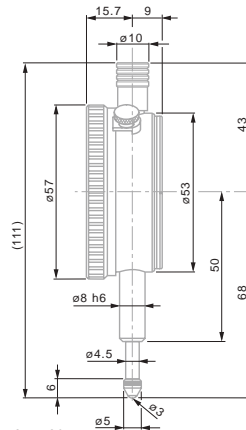

01410610 - 01410611

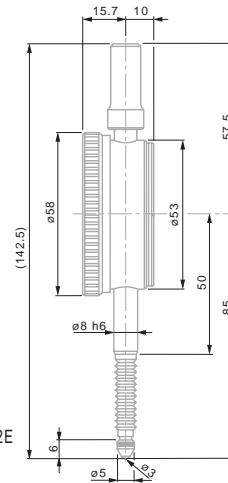

532E

Permissible limits of a metrological characteristic (MPE/MPL)

	± 0,5	10 mm
	7 µm	15 µm
Deviation span within the selected local measuring span 0.10 mm	5 µm	8 µm
Total deviation span	9 µm	17 µm
	3 µm	3 µm
	3 µm	3 µm
	= 1 N -	≤ 1,5 N ≤ 2,2 N



EN ISO 463
Factory standard



Rotating dial. With
or without dial lock
for standard models



0,01 mm



Full-metal dial
casing. Mounting
shank and plunger
in hardened stain-
less steel



See table for
tolerance limits



With or without anti-
shock mechanism



Adjustable tolerance
markers. Thread
M2,5 for measuring
insert



Measuring insert
with Ø 3 mm ball tip
already mounted



Cardboard box



Identification
number



Inspection report
with declaration of
conformity

Dial Ø 58 mm – Reading 0,01 mm – Long travel

Long range precision dial gauges



EN ISO 463
Factory standard

Rotating dial. With
or without dial lock.

0,01 mm

Full-metal dial
casing. Mounting
shank and plunger
in hardened stain-
less steel

See table for
tolerance limits

Adjustable tolerance
markers. Thread
M2,5 for measuring
insert

Measuring insert
with 3 mm ball tip
already mounted

Cardboard box

Identification
number

Inspection report
with declaration of
conformity



712

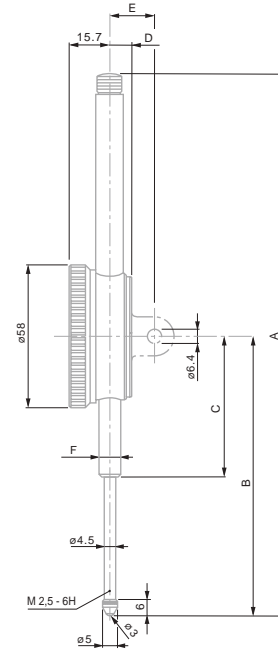

No	=									
		mm	mm	mm	mm	mm				
712	COMPAC 712	30	30,5	0,01	1	0 ÷ 50 ÷ 100	●	–	–	58
722	COMPAC 722	50	50,5	0,01	1	0 ÷ 50 ÷ 100	●	–	–	58
732	COMPAC 732	100	100,5	0,01	1	0 ÷ 50 ÷ 100	●	–	–	58

Dimensions

mm	30 mm	50 mm	100 mm
A	148	228	390
B	88	117,2	211,6
C	50	60	103,6
D	10	9	9
E	20	19	19
F	Ø 8h6	Ø 8h6	Ø 8h6

Permissible limits of a metrological characteristic (MPE/MPL)

	Deviation span	20 µm	25 µm	30 µm
	Total deviation span	25 µm	30 µm	35 µm
	Repeatability limit	3 µm	3 µm	3 µm
	Max. hysteresis	5 µm	5 µm	8 µm
	Measuring force	≤ 2,2 N	≤ 2,5 N	≤ 3,2 N



Dial Ø 82 mm – Reading 0,01 mm

Precision dial gauges



01410910

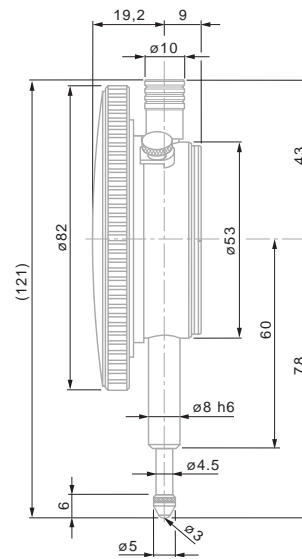

01410910



EN ISO 463
Factory Standard



Rotating dial. With
ot without dial lock



0,01 mm



Full-metal dial ca-
sing. Stainless steel
fixing shank and
plunger, hardened



See table for
tolerance limits



High performance
shock-proof system
in the 2 directions



M2,5 thread for
measuring insert



Measuring insert
with Ø 3 mm ball tip,
already mounted



Cardboard box



Identification
number



Inspection report
with declaration of
conformity

01410910	10	10,5	0,01	0,1	0 ÷ 50 ÷ 100	●	●

Permissible limits of a metrological characteristic (MPE/MPL)

		10 mm
	Deviation span	15 µm
	Deviation span within partial measuring span of 0,10 mm	8 µm
	Total deviation span	17 µm
	Repeatability limit	3 µm
	Max. hysteresis	3 µm
	Measuring force	≤ 1,4 N

Dial Ø 40 mm – Reading 0,002 mm

Precision dial gauges

- EN ISO 463 Factory standard
- Rotating dial
- 0,002 mm
- Full-metal casing. Fixing shank and plunger in hardened stainless steel
- See table for tolerance limits
- Adjustable tolerance markers. Thread M2,5 for measuring insert
- Measuring insert with Ø 3 mm ball tip already mounted
- Cardboard box
- Identification number
- Inspection report with declaration of conformity



355E



365S

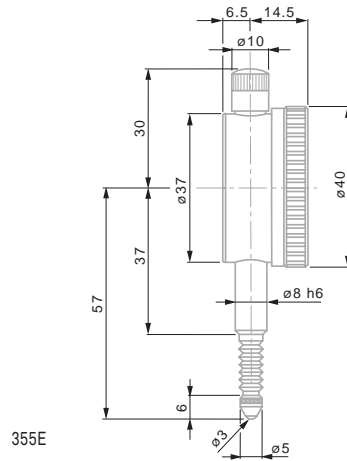

355E

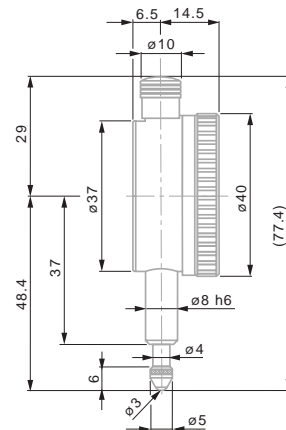

365S

	mm	mm	mm	mm					
355	3	3,3	0,002	0,2	0 ÷ 10 ÷ 20	●	-	40	
355E	3	3,3	0,002	0,2	0 ÷ 10 ÷ 20	●	-	40	IP 54
365S	±0,08	1,5	0,002	0,2	8 ÷ 0 ÷ 8	●	-	40	

Permissible limits of a metrological characteristic (MPE/MPL)

	±0,08 mm	3 mm
Deviation span	2 µm	10 µm
Deviation span within the selected local measuring span 0,10 mm	2 µm	6 µm
Total deviation span	4 µm	12 µm
Repeatability limit	1 µm	1,5 µm
Max. hysteresis	1 µm	2 µm
Measuring force - Model IP54	≤ 1,4 N -	≤ 1,4 N ≤ 1,7 N



Dial Ø 58 mm – Reading 0,002 mm

Precision dial gauges



01416034



555



565S



555E

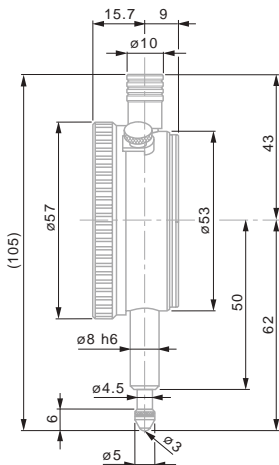

01416034

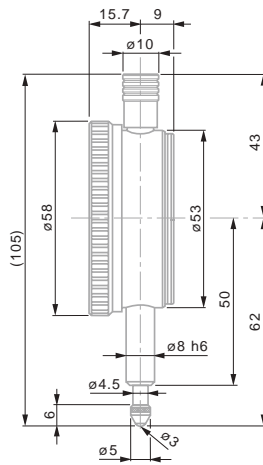

555

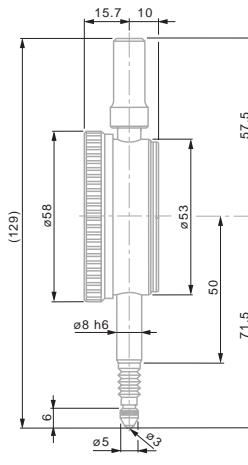

555E



EN ISO 463
Factory standard



Rotating dial. With or without dial lock.



0,002 mm



Full-metal dial casing. Mounting shank and plunger in hardened stainless steel



See table for tolerance limits



Adjustable tolerance markers. Thread M2,5 for measuring insert



Measuring insert with 3 mm ball tip already mounted



Cardboard box



Identification number



Inspection report with declaration of conformity

No	=									
		mm	mm	mm	mm					
01416034	MERCER 253-1	5	5,3	0,002	0,2	0 ÷ 10 ÷ 0	-	●	58	-
555	COMPAC 555	5	5,3	0,002	0,2	0 ÷ 10 ÷ 20	●	-	58	-
555E	COMPAC 555E IP54	5	5,3	0,002	0,2	0 ÷ 10 ÷ 20	●	-	58	IP 54
565S	COMPAC 565S limited travel	±0,08	3,3	0,002	0,2	8 ÷ 0 ÷ 8	●	-	58	-

Permissible limits of a metrological characteristic (MPE/MPL)

	±0,08 mm	5 mm
	4 µm	12 µm
	4 µm	14 µm
	1 µm	2 µm
	1 µm	2 µm
	≤ 1,5 N	≤ 1,5 N
	-	≤ 1,7 N

Dial Ø 40 mm – Reading 0,001 mm

Precision dial gauges



N EN ISO 463
Factory standard

Cardboard box

0,001 mm

Full-metal dial casing. Mounting shank and plunger in hardened stainless steel

See table for tolerance limits

With shock-proof mechanism, in both directions

Adjustable tolerance markers. Thread M2,5 for measuring insert

Measuring insert with 3 mm steel ball tip already mounted

Cardboard box

Identification number

Inspection report with declaration of conformity



01410010



01410120

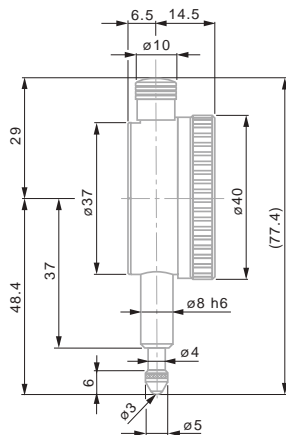

01410010

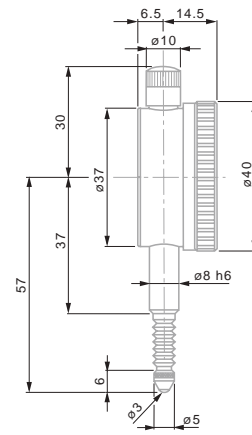

01410120

No	=										
		mm	mm	mm	mm	mm					
01410010	TESA YR	1	1,5	0,001	0,1	40	0 ÷ 50 ÷ 100	●	●	40	–
01412510	TESA YE	1	1,5	0,001	0,1	40	0 ÷ 50 ÷ 100	●	–	40	–
01410120	TESA YR IP54	1	1,5	0,001	0,1	40	0 ÷ 50 ÷ 100	●	–	40	IP 54
367	COMPAC 367	1	1,5	0,001	0,1	40	0 ÷ 5 ÷ 10	●	–	40	–
367E	COMPAC 367E IP54	1	1,5	0,001	0,1	40	0 ÷ 5 ÷ 10	●	–	40	IP 54

Permissible limits of a metrological characteristic (MPE/MPL)

	1 mm	
	Deviation span	4 µm
	Deviation span within the selected local measuring span 0,10 mm	4 µm
	Total deviation span	5 µm
	Repeatability limit	1 µm
	Max. hysteresis	1 µm
	Measuring force	≤ 1,7 N
	– Model IP54	≤ 2 N



Dial Ø 58 mm – Reading 0,001 mm

Precision dial gauges



01412511



556



01412611

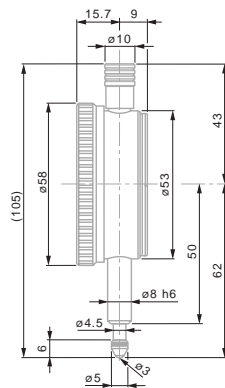

567

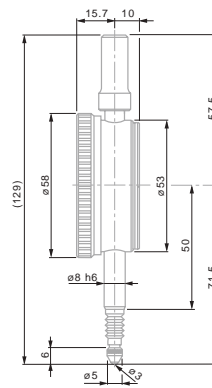

556E

- EN ISO 463
Factory standard
- 0,001 mm
- Full-metal dial casing. Mounting shank and plunger in hardened stainless steel
- See table for tolerance limits
- Effective anti-shock in the 2 directions
- Adjustable tolerance markers. Thread M2,5 for measuring insert
- Measuring insert with 3 mm Ø ball tip, already mounted
- Cardboard box
- Identification number
- Inspection report with declaration of conformity

No	Symbol	mm	mm	mm	mm	mm	mm	mm	mm	mm	mm	mm
01412511	TESA YE	1	1,5	0,001	0,1	58	0 ÷ 50 ÷ 100	●	-			
01412611	TESA YE	5	5,3	0,001	0,2	58	0 ÷ 100 ÷ 200	●	-			
556	COMPAC 556	5	5,3	0,001	0,2	58	0 ÷ 10 ÷ 20	●	-			
567	COMPAC 567	1	3,3	0,001	0,1	58	0 ÷ 5 ÷ 10	●	-			
556E	COMPAC 556E IP54	5	5,3	0,001	0,2	58	0 ÷ 10 ÷ 20	●	-			IP54
01412711	TESA YE IP54	1	1,5	0,001	0,1	58	0 ÷ 50 ÷ 100	●	-			IP54
01410520	TESA YR IP54	1	3,3	0,001	0,1	58	0 ÷ 50 ÷ 100	●	-			IP54

Permissible limits of a metrological characteristic (MPE/MPL)

	1 mm	5 mm
Deviation span	4 µm	12 µm
Deviation span within the selected local measuring span 0,10 mm	4 µm	-
Total deviation span	5 µm	14 µm
Repeatability limit	1 µm	2 µm
Max. hysteresis	1 µm	2 µm
Measuring force	≤ 1,7 N	≤ 1,5 N
- Models IP54	-	≤ 1,7 N

Dial Ø 82 mm – Reading 0,001 mm

Precision dial gauges

- EN ISO 463 Factory standard
- Rotating dial. With or without dial lock.
- 0,001 mm
- Full-metal dial casing. Stainless steel fixing shank and plunger, hardened
- See table for tolerance limites
- High performance anti-shock system in both directions
- M2,5 thread for measuring inserts
- Measuring insert with Ø 3 mm ball tip, already mounted
- Cardboard box
- Identification number
- Inspection report with a declaration of conformity



556G



01410810

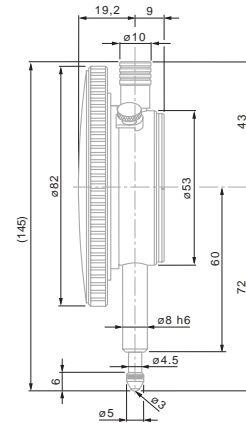

01410810

No	=								
		mm	mm	mm	mm				
01410810	TESA YR	1	3,3	0,001	0,1	0 ÷ 50 ÷ 100	●	●	82
556G	COMPAC 556G	5	5,3	0,001	0,2	0 ÷ 10 ÷ 20	●	-	82

Permissible limits in a metrological characteristic (MPE/MPL)

	1 mm	5 mm
Deviation span	4 µm	12 µm
Deviation span within partial measuring span of 0,10 mm	4 µm	-
Total deviation span	5 µm	14 µm
Repeatability limit	1 µm	2 µm
Max. hysteresis	1 µm	2 µm
Measuring force	≤ 1,7 N	≤ 1,5 N



STANDARD DIAL GAUGES

The Standard product line offers a range of heavy duty and competitively priced dial gauges.

Dial Ø 40 / 58 – Reading 0,1 mm

Precision dial gauges

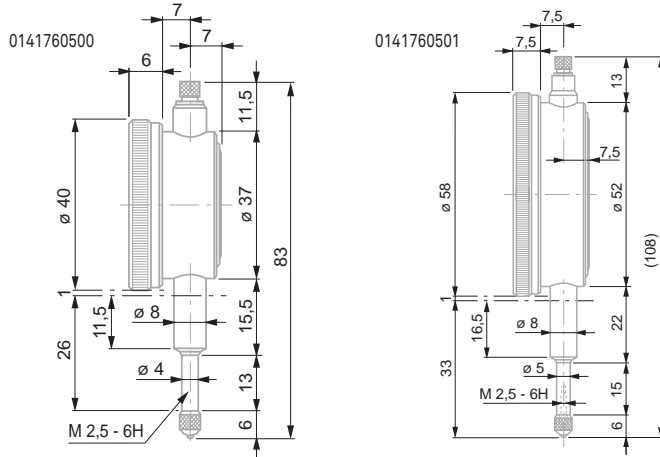

0141760500
0141760501

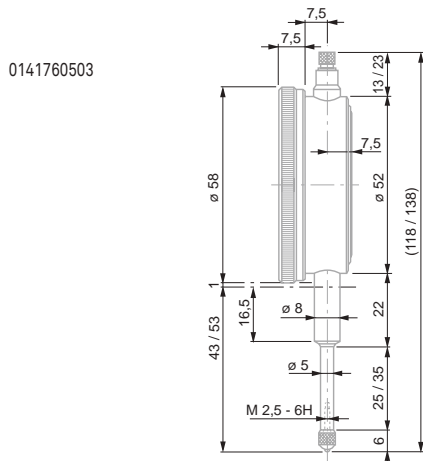

0141760503



EN ISO 463
Factory standard



Rotating dial



0,1 mm

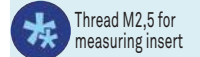
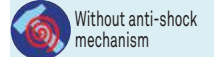

0141760500	10	10,5	0,1	10	0 ÷ 5 ÷ 10	-	≤ 1,0
0141760501	10	10,5	0,1	10	0 ÷ 5 ÷ 10	-	≤ 1,0
0141760503	30	30,5	0,1	10	0 ÷ 5 ÷ 10	-	≤ 1,5

Permissible limits of a metrological characteristic (MPE/MPL)

	10 mm
Deviation span	40 µm
Deviation span within partial measuring span of 0.1 mm	25 µm
Total deviation error	55 µm
Repeatability limit	15 µm
Max. hysteresis	15 µm

Dial Ø 40 mm – Reading 0,01 mm

Precision dial gauges

Model 0141760560 provides excellent value for money.



0141760560



01419047

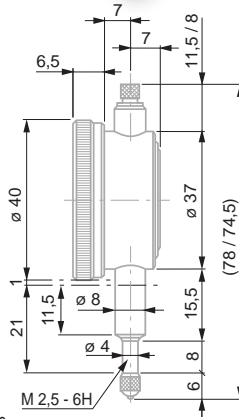

0141760560

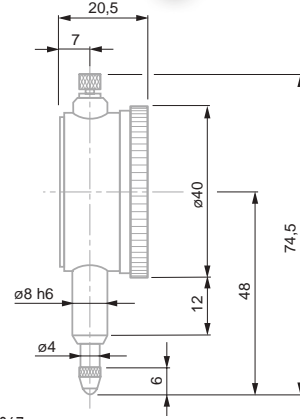

01419047



EN ISO 463
Factory standard

Rotating dial

0,01 mm

Full-metal casing.
Mounting shank and
plunger in hardened
stainless steel

See table for
maximum deviations

With or without anti-
shock mechanism

Adjustable tolerance
markers. Thread
M2,5 for measuring
insert

Measuring insert
with 3,175 mm
Ø ball tip already
mounted

Plastic case or
cardboard box

Identification
number

Inspection report
with declaration of
conformity

				mm	mm	mm	mm		
0141760560 *			ROCH	3	3,4	0,01	0,5	0 ÷ 25 ÷ 50	-
01419047			ETALON	5	-	0,01	0,5	0 ÷ 25 ÷ 50	●

* With extra reverse numbering in red

Permissible limits of a metrological characteristic (MPE/MPL)

	3 mm	5 mm
Deviation span	10 µm	12 µm
Deviation span within the selected partial measuring span of 0,1 mm	5 µm	6 µm
Total deviation span	12 µm	-
Repeatability limit	3 µm	3 µm
Max.hysteresis	3 µm	-
Measuring force	≤ 1,4 N	≈ 1



Dial Ø 58 mm – Reading 0,01 mm – Long travel

Long travel precision dial gauges



0141760635



0141760624



0141761213



0141760661



0141760651

0141760631
0141760635

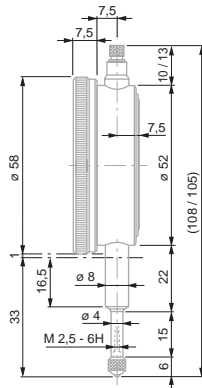

0141761213

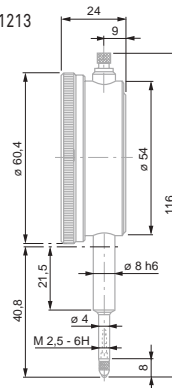

0141760624

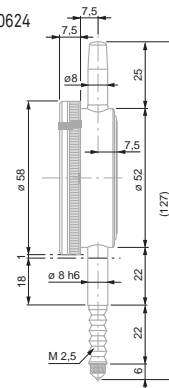

0141760651
0141760653

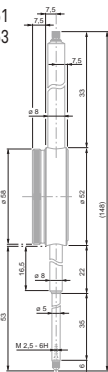

0141760661

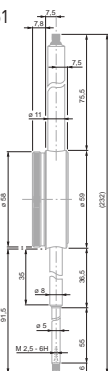

No	Symbol	mm	mm	mm	mm	mm	N	Other
0141760631 *	ROCH	10	10,5	0,01	1	0 ÷ 50 ÷ 100	-	≤ 1,4
0141760635 *	ROCH	10	10,5	0,01	1	0 ÷ 50 ÷ 100	-	≤ 1,4
0141761213 **	ROCH	15	15,5	0,01	1	0 ÷ 50 ÷ 100	●	≤ 1,6
0141760651	ROCH	30	30,5	0,01	1	0 ÷ 50 ÷ 100	-	≤ 1,6
0141760653	ROCH	30	30,5	0,01	1	0 ÷ 50 ÷ 100	●	≤ 2,2
0141760624 *	ROCH IP54	10	10,5	0,01	1	0 ÷ 50 ÷ 100	●	≤ 2 IP54
0141760661	ROCH	50	51	0,01	1	0 ÷ 50 ÷ 100	-	≤ 2,2

* With extra reverse numbering in red

** Ø Dial 60,4 mm

Permissible limits of a metrological characteristic (MPC/MPE)

	10 mm	15 mm	30 mm	50 mm	80 mm
Deviation span	15 µm	20 µm	20 µm	25 µm	30 µm
Deviation span within the selected local measuring span 0,10 mm	5 µm	5 µm	5 µm	5 µm	5 µm
Repeatability limit	3 µm	3 µm	3 µm	3 µm	3 µm



EN ISO 463
Factory standard



Rotating dial



0,01 mm



Full-metal casing.
Mounting shank and
plunger in hardened
stainless steel



See reference table



With or without anti-
shock mechanism



Adjustable tolerance
markers. Model No.
0141760640 with fine
adjust for dial reading
mounted under
protective cap. Thread
M2,5 for measuring
insert



Accuracy: see table
for max. deviations.
If measurements are
carried out with a
downward plunger,
the same must be
mechanically
coupled to the
measuring point
to eliminate all
hysteresis



Measuring insert
with Ø 3,175 mm
steel ball tip,
already mounted.
Exceptions:
Model numbers
0141760631 /
0141761213 with
ruby ball tips.



Plastic case or
cardboard box



Identification
number



Declaration of
conformity

Dial Ø 58 mm – Reading 0,01 mm – Standard and long travel

Precision dial gauges

Standard and long travel models

- EN ISO 463 Factory standard
- Rotating dial
- 0,01 mm
- Full-metal casing. Mounting shank and plunger in hardened stainless steel
- See reference table
- With or without anti-shock mechanism
- Adjustable tolerance markers. Thread M2,5 for measuring insert
- Measuring insert with Ø 3,175 mm steel ball tip, already mounted
- Plastic case or cardboard box
- Identification number
- Declaration of conformity



01419048

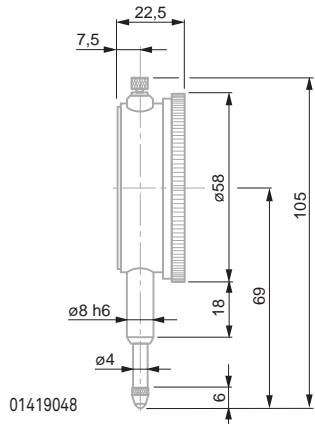

01419048

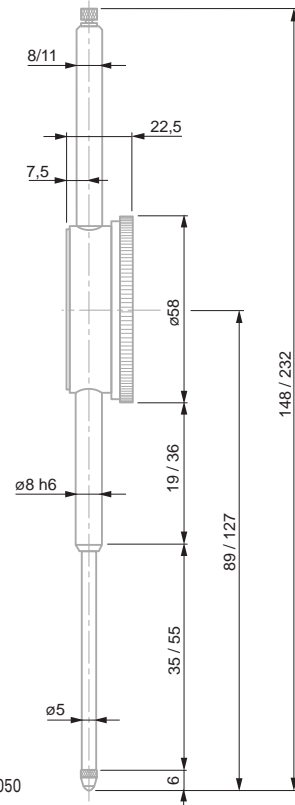

01419050

	mm	mm	mm			N	
01419048	10	0,01	1	0 ÷ 50 ÷ 100	–	≈1	58
01419050	50	0,01	1	0 ÷ 50 ÷ 100	●	1,5 ÷ 2	58

For magnetic or central lug backs, see backs for ROCH and ETALON dial gauges

Permissible limits for a metrological characteristic (MPE/MPL)

	mm	10	50
	Deviation span	µm	15 25
	Deviation span within selected partial measuring span 0,10 mm	µm	8 12
	Repeatability Limit	µm	3 3



DIAL GAUGES – ANALOGUE WITH BACK MOUNTED PLUNGER

Mechanical dial gauges with back mounted plungers differentiate by their concept of presenting a display which is perpendicular to the movement of the measuring stem.

Dial Ø 40 mm – Reading 0,01 or 0,002 mm



CP352S



CP353



CP355

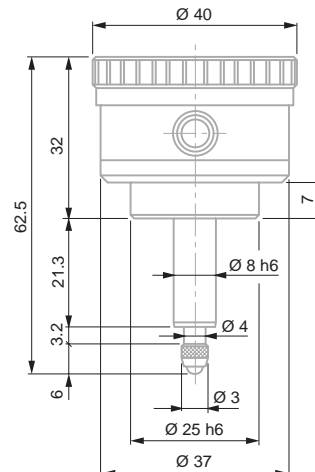

CP353



EN ISO 463
Factory standard



Rotating dial



Full-metal casing.
Mounting shank and
plunger in hardened
stainless steel



See reference table



With anti-shock
mechanism



Adjustable tolerance
markers. Thread
M2,5 for measuring
insert. Fastening
with sleeve Ø 8h6
and 25h6



Measuring insert
with Ø 3 mm steel
ball tip, already
mounted



Cardboard box



Identification
diameter



Inspection report
with declaration of
conformity

		mm	mm	mm	µm	µm	µm	mm	mm	N		
CP 353	COMPAC CP353	3	3,2	0,01	14	3	3	0,5	0 ÷ 25 ÷ 50	0,9		
CP 355	COMPAC CP355	3	3,2	0,002	14	2,2	2,5	0,2	0 ÷ 10 ÷ 20	0,9		
CP 352S	COMPAC CP352S with limited travel	± 0,4	3,2	0,01	9	3	3	(1)	40 ÷ 0 ÷ 40	0,9		

S: Limited range of indication, restricted reading.
The needle makes less than one revolution of the dial, all reading errors due to revolution counter are eliminated.

INSERTS FOR DIAL GAUGES, AXIAL PROBES, ETC. - EXECUTION WITH M2,5 THREAD

Spherical measuring inserts, standard.

No	
03510001	Steel
03510002	Carbide
03560001	Sapphire

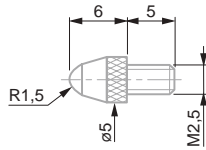

Spherical measuring insert, short

No	
03560007	Carbide

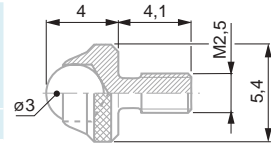

Spherical measuring inserts, long

No	
03560019	Steel
03560020	Carbide
03560021	Ruby

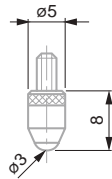

Spherical measuring inserts, R = 0,5 mm.

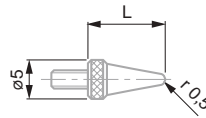

No			L mm
03560035	Steel		5
03560036	Steel		10
03560037	Steel		15
03560038	Steel		20
03560039	Steel		30
03560040	Steel		40

Spherical measuring inserts

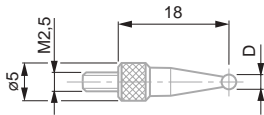

No			D, mm
03560051	Carbide		1
03560052	Carbide		2
03560053	Carbide		3
03560054	Carbide		4
03560055	Carbide		5
03560056	Carbide		6
03560057	Carbide		7
03560058	Carbide		8

Spherical measuring insert with 4 interchangeable pins, R = 1,5 mm

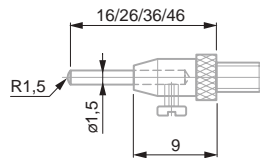

No			L, mm
03510201	Steel		16, 26, 36, 46

Spherical measuring inserts

No	
03510101	Steel
03510102	Carbide

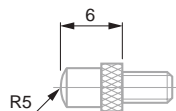

Spherical measuring inserts

No	
03560017	Steel
03560018	Carbide

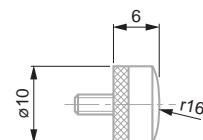

Measuring insert with offset (A)
Pointed measuring face
Lock nut for radial alignment.

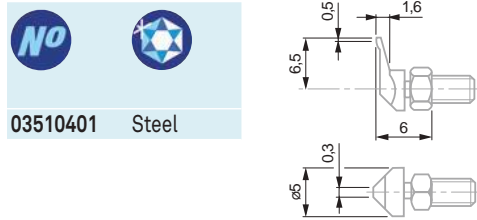

03510401 Steel

Measuring insert with offset (A)
Pointed measuring face
Lock nut for radial alignment.

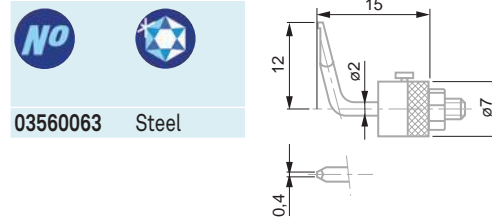

03560063 Steel

Measuring insert with needle contact point

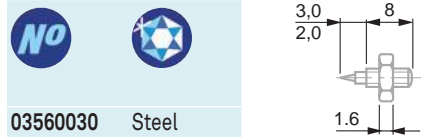

03560030 Steel

Measuring inserts with ball-bearing rollers
Lock nut for radial alignment

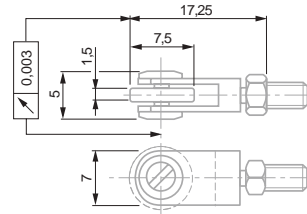

No	Shape	Material
03560010	Cylindrical	Steel
03560011	Domed	Steel

Inserts with a knife blade measuring face
Lock nut for radial alignment

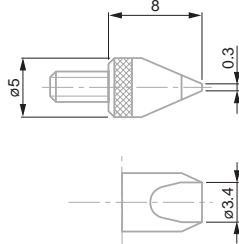

No	Material	B, mm
03560024	Steel	0,3
03560025	Steel	0,3

Inserts with a knife blade steel face
Lock nut for radial alignment

No	L, mm
03560031	5
03560032	10
03560033	15
03560034	20

Insert with a cylindrical measuring face
Lock nut for radial alignment

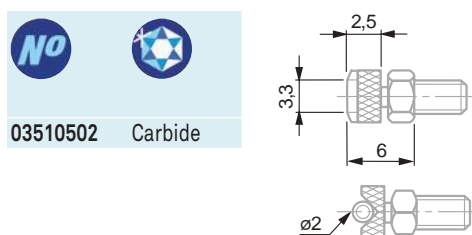

03510502 Carbide

Insert with a narrow, off-centre measuring face
Lock nut for radial alignment

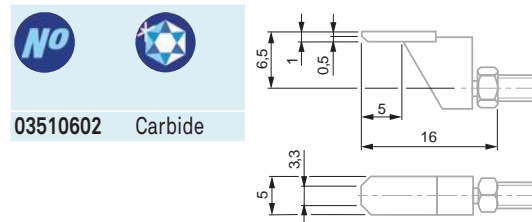

03510602 Carbide

Insert with a narrow measuring face
Parallelism adjustable
Lock nut for radial alignment



03510702 Carbide

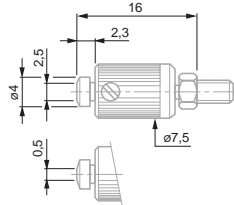

Inserts with a flat measuring face.

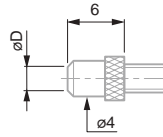

03510801	2,5	Steel
03510802	2,5	Carbide
03560022	3,4	Steel
03560023	3,4	Carbide

Insert with a flat measuring face
Parallelism adjustable
Counter-nut for radial alignment



03510902 Métal dur

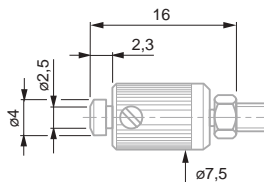

Inserts with a flat measuring face, in steel

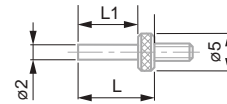

No.	L, mm	L1, mm
03560026	5	2,8
03560027	10	7,8
03560028	15	12,8
03560029	20	17,8

Inserts with interchangeable pins
Flat measuring face



03560008 Steel
03560009 Carbide

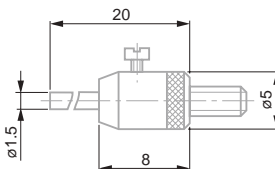

Inserts with flat measuring face

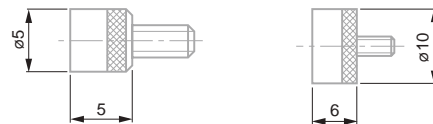

03560012	5	Steel
03560013	5	Carbide
03560014	10	Steel
03560015	10	Carbide
03560016	20	Steel

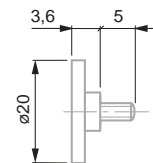

Connectors for measuring inserts

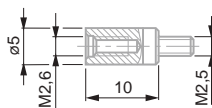

No.	Outside	Inside
03560092	M2,5	M2
03560065	M3	M2,5

Extensions for measuring inserts



No.	L, mm
03560042	10
03560043	15
03560044	20
03560045	25
03560046	30
03560047	35
03560048	40
03560049	45
03560050	50

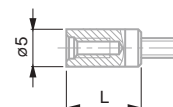

Extensions for measuring inserts.

No	L, mm
03540501	10
03540502	15
03540503	20
03540504	40

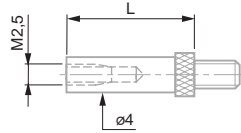

– EXECUTIONS WITH A M2 COUPLING THREAD



Spherical measuring inserts, M2 thread

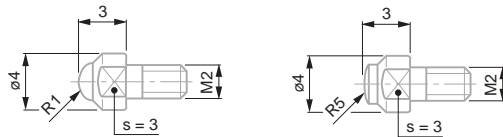

No	mm	
03510204	R 1	Carbide
03510103	R 5	Carbide

Spherical measuring inserts, R = 5 mm, M2 thread

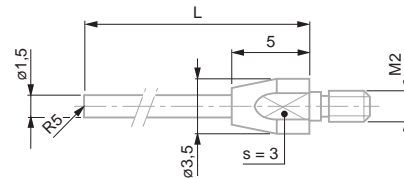

No		L, mm
03510202	Carbide	16
03510203	Carbide	26

Measuring insert with cylindrical measuring face. Lock nut for radial alignment, M2 thread

No	Carbide
03510503	

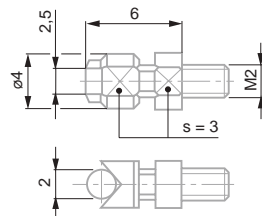

Extensions for measuring inserts, M2

No	L, mm
03540505	10
03540506	15

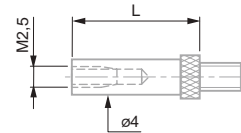

ADDITIONAL ACCESSORIES FOR DIAL GAUGES



Device for plunger retraction for mounting on the bottom stem

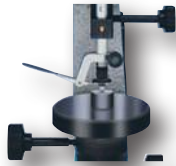

No



Consisting of:

- 03540104 - 03540101: Lever
- 03540102: Washer

Device for plunger retraction for mounting on the top stem

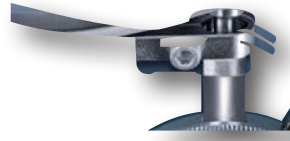

No



mm

- 03560004 Ø 40
03560005 Ø 58



Retraction lever Bottom mounted lift lever

No



- 01960005 Bottom mounted lift lever
Contains only lifting lever



90° angle probe. For the transmission of movements of the measuring plunger. Max. travel up to 10 mm. For dial gauges of 0,01 mm

No



- 03560006 90° angular probe
03560012; Insert with flat measuring face, Ø 5 mm



Magnetic force = 150 N

A Matt chrome plated except for tinted model numbers 01460010, 01460011

Backs for ROCH and ETALON Dial Gauges

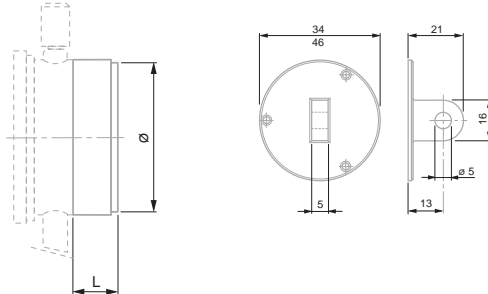

No



Bezel diameter, mm



Back, mm



- 01462004 40 34 Back with central lug
01462005 58, 60, 80 46 Back with central lug

Backs for dial gauges TESA YR – YE / MERCER / COMPAC / DIGICO 200-700 – Ø 40 mm dial models

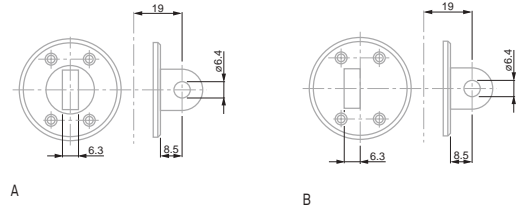

No



- 01460008 A – back with centre lug
01460009 B – Back with offset lug



Magnetic holding force = 150 N

A Dull chrome-plated except for model numbers 01460016, 01460017.

Backs for dial gauges TESA YR – YE / MERCER / COMPAC / DIGICO 200-700 – Ø 58 and 82mm dial models



- 01460014 C
01460015 D

