

Type FGWA

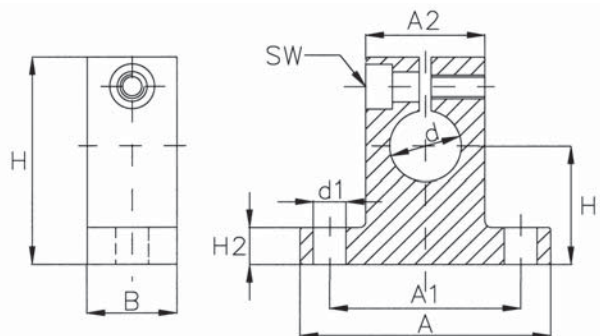

Support aluminium



Référence Type	Dimensions - mm										Poids - Weight
	Ø d	A	B	H	H1	A1	A2	d1	SW	H2	g
FGWA12	12	42	12	35	20	32	20	5,5	M3	5,5	26
FGWA16	16	50	16	42	25	40	28	5,5	M3	6,5	39
FGWA20	20	60	20	50	30	45	32	5,5	M4	8	78
FGWA25	25	74	25	58	35	60	38	6,6	M5	9	135
FGWA30	30	84	28	68	40	68	45	9	M6	10	200
FGWA40	40	108	32	86	50	86	56	11	M8	12	362
FGWA50	50	130	40	100	60	108	80	11	M8	14	740
FGWA60	60	160	48	124	75	132	100	13,5	M8	15	1 400

