

Tipo Type Modelè	Anello int. Inner race Bague intérieure		Anello est. Outer race Bague extérieure		Spazio radiale Sprag space Espace radial			Numero clips Number of clips Nombre de clips	Numero corpi di contatto Number of sprags Nombre de cames	Peso Weight Masse [kg]		
	T_N [Nm]	$n_{max}^{(1)}$ [min ⁻¹]	$n_{max}^{(2)}$ [min ⁻¹]	ϕd [mm]	ϕD [mm]	c_{min} [mm]	ϕd_{max} [mm]				ϕD_{min}	
GP2222G	63	8600	4300	22,225	38,885	8,33 ^{±0,1}	10,0	15	50	-	12	0,030
GP2776	119	6900	3400	27,762	44,422	8,33 ^{±0,1}	13,5	18	58	-	14	0,055
GP3034	124	6300	3100	30,340	47,000	8,33 ^{±0,1}	13,5	20	62	-	14	0,060
GP3175(3C)	159	6000	3000	31,750	48,410	8,33 ^{±0,1}	13,5	21	63	3	16	0,060
GP3809A	275	5000	2500	38,092	54,752	8,33 ^{±0,1}	16,0	25	71	-	18	0,085
GP4127(3C)	224	4600	2300	41,275	57,935	8,33 ^{±0,1}	13,5	27	75	3	18	0,090
GP4445A	363	4300	2100	44,450	61,110	8,33 ^{±0,1}	16,0	29	79	-	20	0,095
GP4972(4C)	306	3800	1900	49,721	66,381	8,33 ^{±0,1}	13,5	33	86	4	22	0,100
GP5476A	525	3500	1700	54,765	71,425	8,33 ^{±0,1}	16,0	36	92	-	24	0,110
GP5476A(4C)	525	3500	1700	54,765	71,425	8,33 ^{±0,1}	16,0	36	92	4	24	0,130
GP5476B(4C)	769	3500	1700	54,765	71,425	8,33 ^{±0,1}	21,0	36	92	4	24	0,180
GP5476C(4C)	990	3500	1700	54,765	71,425	8,33 ^{±0,1}	25,4	36	92	4	24	0,200
GP5776A	604	3300	1600	57,760	74,420	8,33 ^{±0,1}	16,0	38	98	-	26	0,110
GP6334B	806	3000	1500	63,340	80,000	8,33 ^{±0,1}	21,0	42	104	-	26	0,175
GP7221(5C)	675	2600	1300	72,217	88,877	8,33 ^{±0,1}	13,5	48	115	5	30	0,140
GP7221B	1279	2600	1300	72,217	88,877	8,33 ^{±0,1}	21,0	48	115	-	30	0,185
GP7221B(5C)	1279	2600	1300	72,217	88,877	8,33 ^{±0,1}	21,0	48	115	5	30	0,210
GP7969C(5C)	2038	2400	1200	79,698	96,358	8,33 ^{±0,1}	25,4	53	124	5	34	0,280
GP8334C	2055	2300	1100	83,340	100,000	8,33 ^{±0,1}	25,4	55	132	-	34	0,270
GP8729A	1250	2200	1100	87,290	103,960	8,33 ^{±0,1}	16,0	58	134	-	34	0,165
GP10323A(3C)*	1612	1800	900	103,231**	119,891	8,33 ^{±0,1}	16,0	68	155	3	40	0,205
GP12334C*	4800	1500	750	123,340**	140,000	8,33 ^{±0,1}	25,4	80	184	-	50	0,400
GP12388C(11C)	4875	1500	750	123,881	142,880	9,50 ^{±0,1}	25,4	80	186	11	44	0,400

IT

$$T_{MAX} = 2 \times T_N$$

1) Anello interno più veloce dell'anello esterno

2) Anello esterno più veloce dell'anello interno

*) Il bordo di centratura della gabbia interna si trova sul lato opposto

**) E' ammissibile un incremento della tolleranza a $\pm 0,013$

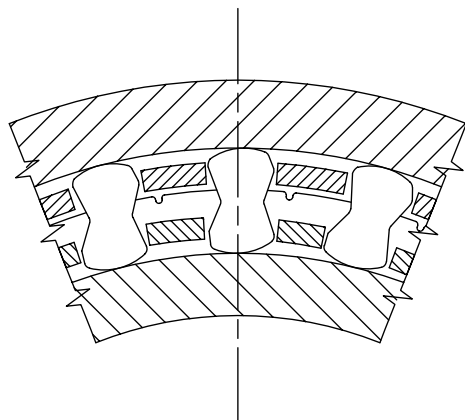

EN

$$T_{MAX} = 2 \times T_N$$

1) Inner race is faster than outer race

2) Outer race is faster than inner race

*) The inner cage centering flange is on the opposite side

**) Extension of tolerance to $\pm 0,013$ permissible

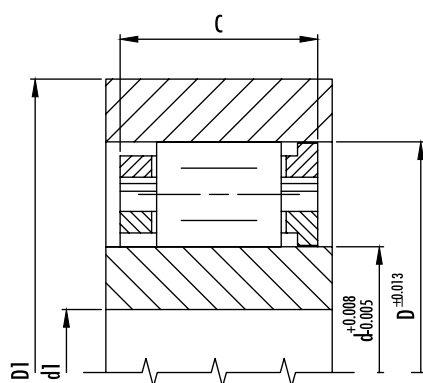

FR

$$T_{MAX} = 2 \times T_N$$

1) Bague interne plus rapide que la bague externe

2) Bague externe plus rapide que la bague interne

*) Le rebord de centrage de la cage intérieure est du côté opposé

**) L'élargissement de la tolérance à $\pm 0,013$ est admissible

