

AL ALP

TYPE

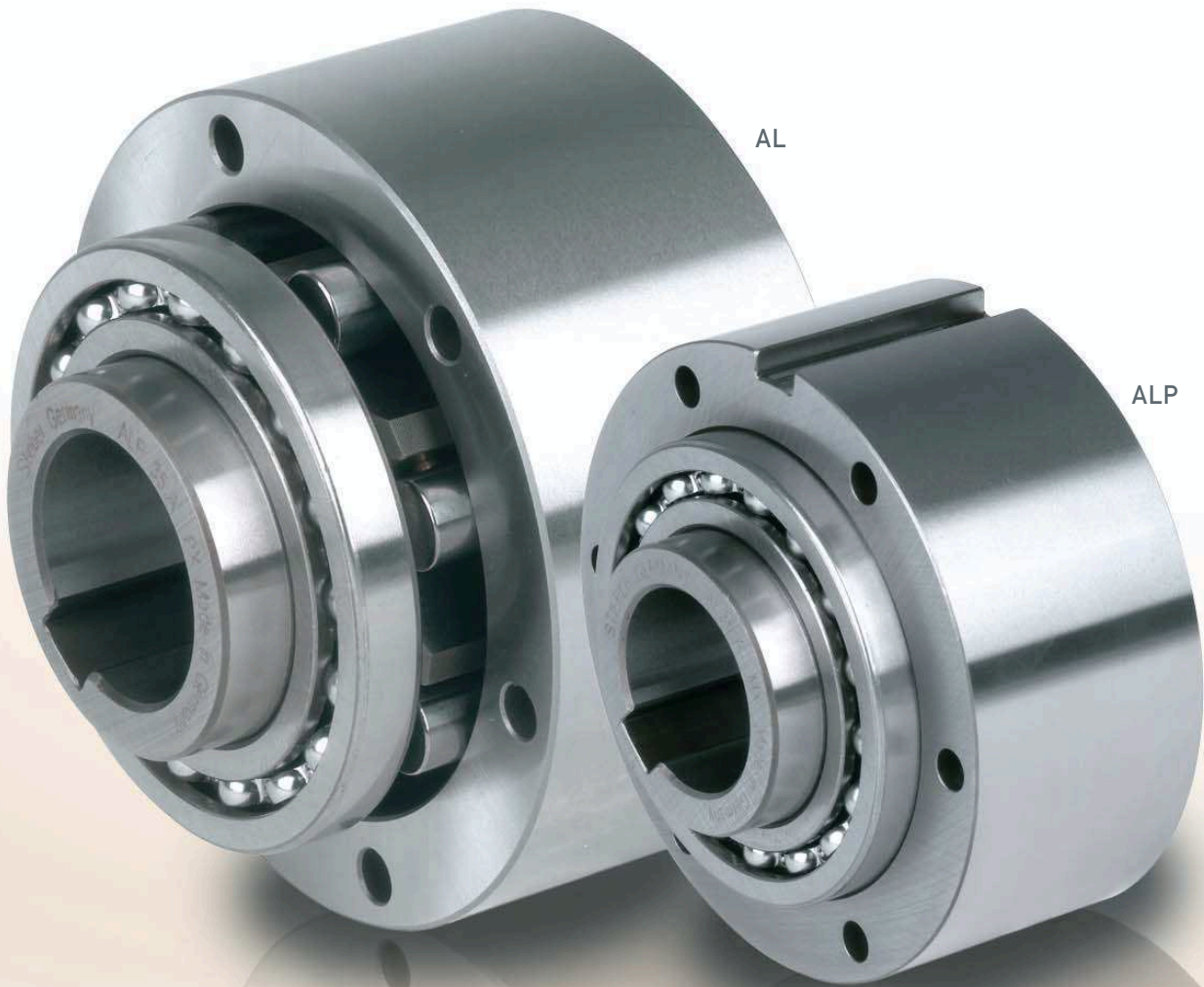

Types AL, ALP are roller type freewheels. These units are part of the Stieber modular system. They are bearing supported, using two 160.. series bearings, and require oil lubrication. These units may be used in designs providing oil lubrication and sealing as on the example overleaf.

The bearings must not be axially stressed. Typically, types AL, ALP are used with standard covers that are designed to transmit torque, and provide oil lubrication

and sealing. Usually these covers are used in pairs according to combinations shown on the following pages. The outer race of the AL model is plain to receive and center any component bored to H7 tolerance. Torque is transmitted by bolts through the cover plate in this case. Types AL, ALP are identical except that type ALP has a keyway on the outside diameter to transmit the torque. Two paper seals are delivered with each unit to be placed between the outer race and cover plates.

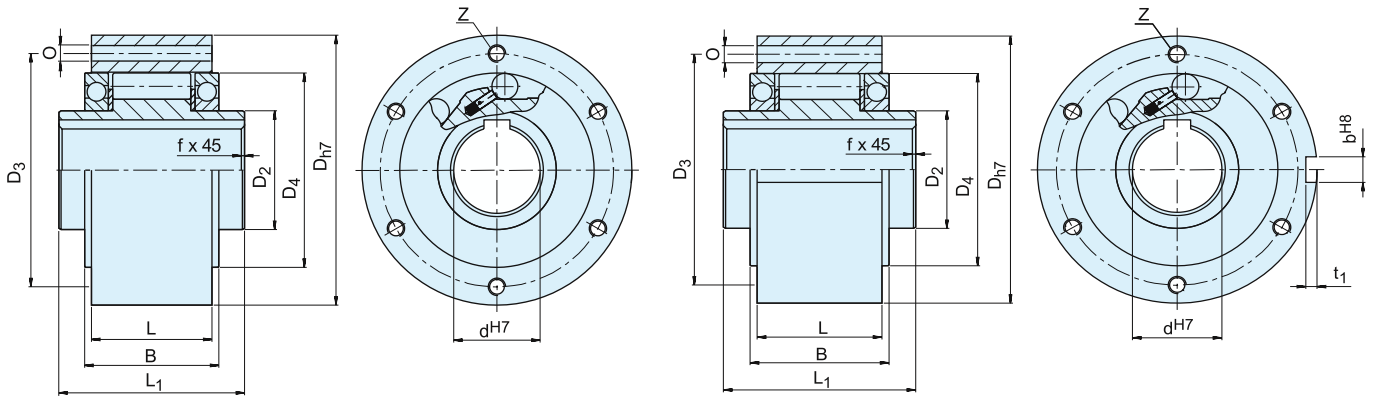

AL

ALP

Type	Size	Overrunning speeds				Number											Weight	Drag torque
		$d_{H7}^{(1)}$ [mm]	$T_{KN}^{(1)}$ [Nm]	$n_{imax}^{(2)}$ [min ⁻¹]	$n_{amax}^{(3)}$ [min ⁻¹]	D_{H7} [mm]	D_2 [mm]	D_4 [mm]	D_3 [mm]	0	z	L^1 [mm]	L^4 [mm]	B [mm]	t_1 [mm]	b^{H8} [mm]		
AL ALP	12	55	4000	7200	62	20	42	51	5.5	3	42	20.3	27	2.4	4	0.5	0.5	3.4
	15	125	3600	6500	68	25	47	56	5.5	3	52	30.3	34.1	2.9	5	0.8	0.8	4.1
	20	181	2700	5600	75	30	55	64	5.5	4	57	34.3	39.1	3.5	6	0.8	1.0	8
	25	288	2100	4500	90	40	68	78	5.5	6	60	37.3	42.1	4.1	8	1.0	1.5	14
	30	500	1700	4100	100	45	75	87	6.6	6	68	44.3	49.1	4.1	8	1.0	2.2	23
	35	725	1550	3800	110	50	80	96	6.6	6	74	48.3	54.1	4.7	10	1.0	3.0	60
	40	1025	1150	3400	125	55	90	108	9	6	86	56.3	62.1	4.9	12	1.5	4.6	72
	45	1125	1000	3200	130	60	95	112	9	8	86	56.3	62.1	5.5	14	1.5	4.7	140
	50	2125	800	2800	150	70	110	132	9	8	92	63.3	69.1	5.5	14	1.5	7.2	180
	55	2625	750	2650	160	75	115	138	11	8	104	67	73.1	6.2	16	2.0	8.6	190
	60	3500	650	2450	170	80	125	150	11	10	114	78	84	6.8	18	2.0	10.5	240
	70	5750	550	2150	190	90	140	165	11	10	134	95	103	7.4	20	2.5	13.5	320
	80	8500	500	1900	210	105	160	185	11	10	144	100	108	8.5	22	2.5	18.2	330
	90	14500	450	1700	230	120	180	206	14	10	158	115	125	8.7	25	3.0	28.5	650
	100	20000	350	1450	270	140	210	240	18	10	182	120	131	9.9	28	3.0	42.5	830
	120	31250	250	1250	310	160	240	278	18	12	202	140	152	11.1	32	3.0	65.0	1080
150	70000	200	980	400	200	310	360	22	12	246	180	196	12.3	36	4.0	138.0	1240	
200	175000	150	750	520	260	400	460	26	18	326	240	265	15	45	5.0	315.0	3800	
250	287500	120	620	610	320	480	545	33	20	396	300	330	15	45	5.0	512.0	6100	
ALM	25	388	2100	2800	90	40	68	78	5.5	6	60	37.3	42.1	4.1	8	1.0	1.7	22
	30	588	1700	2500	100	45	75	87	6.6	6	68	44.3	49.1	4.1	8	1.0	2.5	37
	35	838	1550	2400	110	50	80	96	6.6	6	74	48.3	54.1	4.7	10	1.0	3.2	66

NOTES

- 1) $T_{max} = 2 \times T_{KN}$
» Refer to Selection page 10 to 13
 - 2) Inner race overruns, values without lip seals
 - 3) Outer race overruns
Keyway to DIN 6885.1
 - 4) The dimension L includes up to size 50 the each 0.25 mm thick paper seals to be located on both faces
- » Refer to mounting and maintenance instructions page 16 to 19

MOUNTING EXAMPLE

